



CATÁLOGO

CONSTRUCCIÓN Y EDIFICACIÓN
METÁLICAS MARESTA

Empresa mexicana especializada en la
comercialización de acero para la industria y la
construcción.



**DISEÑAMOS TU
PROYECTO ESTRUCTURAL**

PROFESIONISTAS EN
**ESTRUCTURAS
METÁLICAS**
DISEÑO, FABRICACIÓN Y MONTAJES



**PERSONAL CERTIFICADO
EN CADA ÁREA**



**ENTREGAS EN TIEMPO
Y FORMA PLANEADA**

¡VAMOS A TODA LA REPÚBLICA MEXICANA!

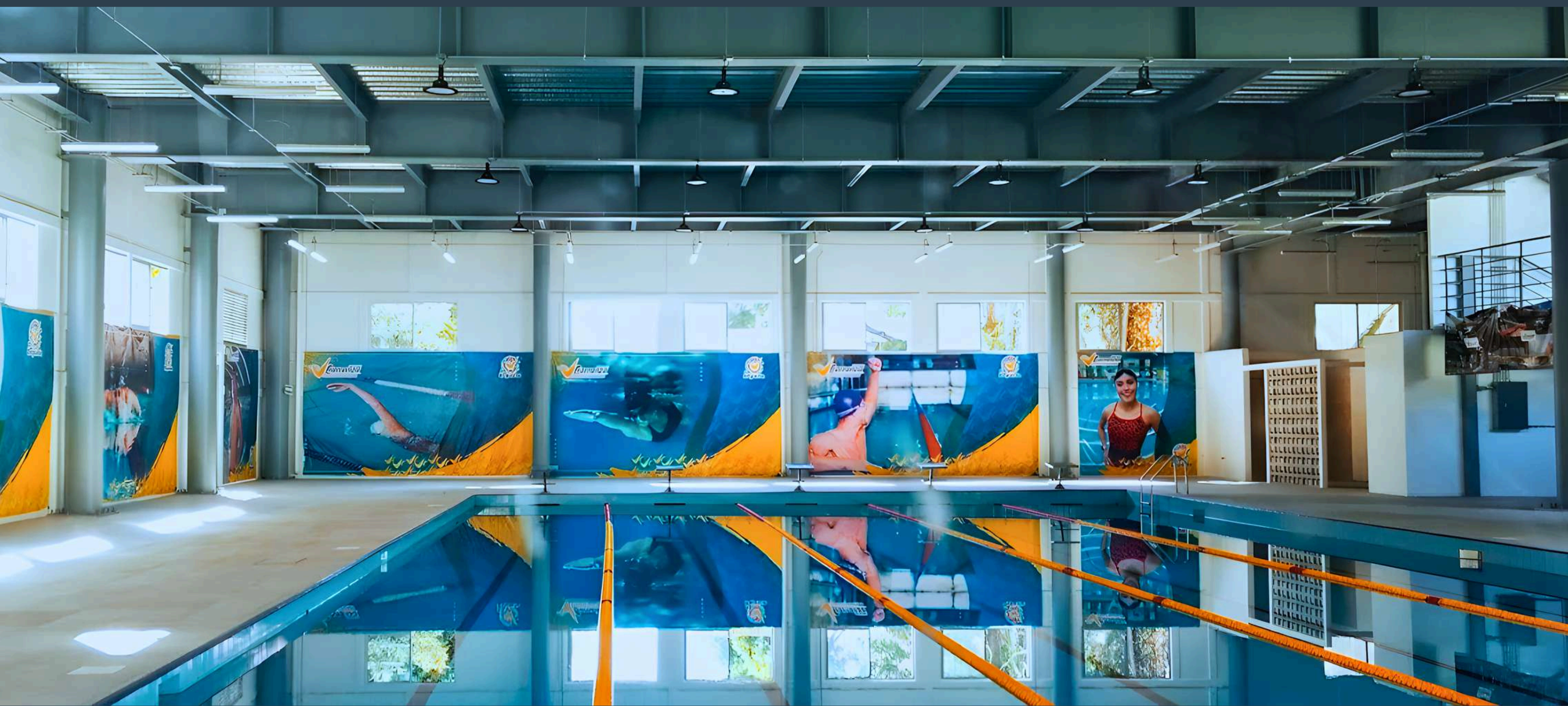

Índice

Ángulo	1
Alambrón, Alambre recocido, Clavo	2
Polín Monten y cuadrado	3
Canal C.P.S.	4
HSS	5
Lámina y placa antiderrapante	7
Lámina Galvanizada	7
Placa de acero en hoja	8
Lámina negra RC Y RF	9
Malla electrosoldada	9
Perfil pintado y zintro	10
P.T.R.	13
Redondo y solera	16
Tablero pintado y zintro	19
Tubería galvanizada y negra C-40	19
Tubería negra C-30	20
Tubería estructural	20
Viga I.P.S.	22
Varilla corrugada R42	23
Viga I.P.R	23
Rejilla de acero	34
Servicios especializados	37
Corte y barrenado	38
Pintura	39
Anclas	39
Tolerancia de espesores	42
Factores de conversión	45

Estimados clientes, sean bienvenidos a **CONSTRUCCIÓN Y EDIFICACIÓN METÁLICAS MARESTA**. Nuestro objetivo es brindarle atención de calidad y el servicio que usted merece, comprometiéndonos en cubrir las necesidades que su proyecto requiere y así ser su mejor alternativa.

ÁNGULO



PULGADAS		MILÍMETROS	PESO kg/m	PESO pza a 6.10	
1/8 x	3/4	3.2 x	19.1	0.88	5.36
	1		25.4	1.19	7.25
	1 1/4		31.7	1.50	9.15
	1 1/2		38.1	1.83	11.16
	2		50.8	2.46	15.00
3/16 x	1	4.8 x	25.4	1.73	10.55
	1 1/4		31.7	2.20	13.42
	1 1/2		38.1	2.68	16.34
	2		50.8	3.63	22.14
	2 1/2		63.5	4.60	28.06
	3		76.2	5.52	33.67
1/4 x	1	6.3 x	25.4	2.22	13.54
	1 1/4		31.7	2.86	17.44
	1 1/2		38.1	3.49	21.28
	2		50.8	4.75	28.97
	2 1/2		63.5	6.10	37.21
	3		76.2	7.29	44.46
	3 1/2		88.9	8.83	53.86
5/16 x	2	7.9 x	50.8	5.84	35.62
	2 1/2		63.5	7.44	45.38
	3		76.2	9.08	55.38
	4		101.6	12.20	74.42
	5		127.0	15.51	94.61
3/8 x	2	9.5 x	50.8	6.99	42.63
	2 1/2		63.5	8.79	53.61
	3		76.2	10.72	65.39
	4		101.6	14.60	89.06
	5		127.0	18.30	111.63
	6		152.4	22.17	135.23

ÁNGULO

PULGADAS		MILÍMETROS		PESO <i>kg/m</i>	PESO <i>pieza a 6.10</i>
1/2 x	2 1/2	12.7 x	63.5	12.03	73.38
	3		76.2	13.99	85.33
	4		101.6	19.05	116.20
	5		127.0	24.11	147.07
	6		152.4	29.17	177.93
5/8 x	6	15.9 x	152.4	36.10	220.21
	8		203.2	48.40	295.24
3/4 x	6	19.1 x	152.4	42.71	260.53
	8		203.2	58.08	354.28
7/8 x	8	22.2 x	203.2	66.97	408.51
1 x	8	25.4 x	203.2	75.90	462.99



ALAMBRÓN

PULG.	F.PULG.	MM	(KG/M)
0.250	1/4"	6.35	0.249

ALAMBRE RECOCIDO



CAL.16 Rollos de 45 a 70 kg/pza



CLAVO

PULGADAS	MILÍMETROS	(KG/CAJA)
2"	50.8	25
2 1/2"	63.5	25
3"	76.2	25
3 1/2"	88.9	25
4"	101.6	25

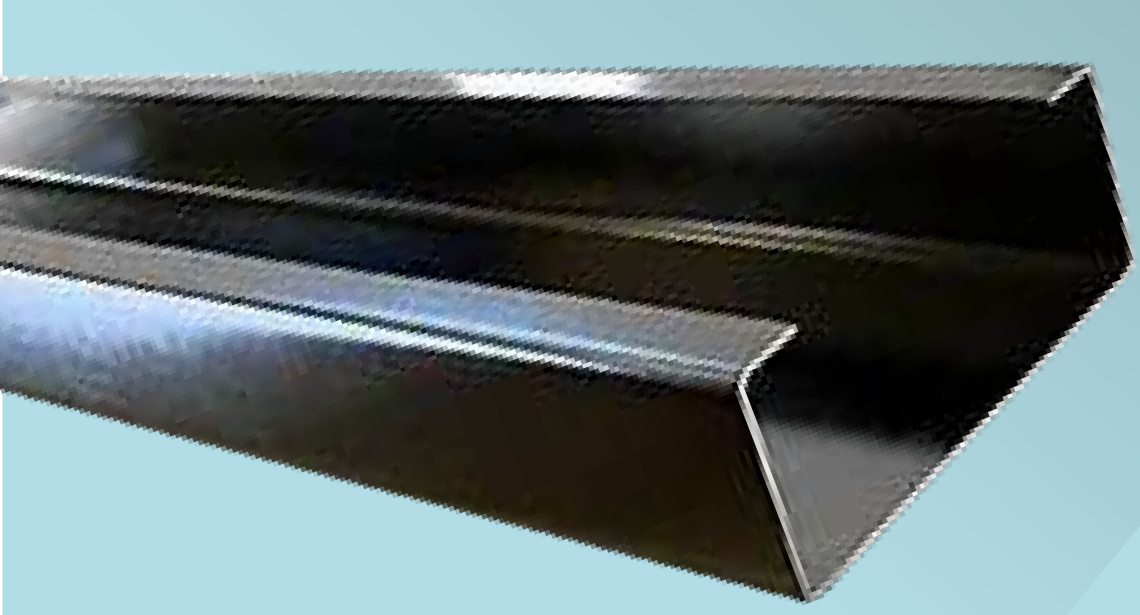

POLÍN MONTEN

PERALTE	LARGO M	CALIBRE	kg/pz
3"	6	14	15.18
4"	6	14	19.70
4"	4	12	18.04
4"	4	10	23.00
5"	5	14	18.40
5"	6	14	22.10
5"	5	12	25.25
5"	5	10	32.40
6"	6	14	24.40
6"	6	12	33.50
6"	6	10	42.70
8"	8	14	43.00
8"	8	12	59.10
8"	8	10	75.70
10"	10	14	61.10
10"	10	12	84.60
10"	10	10	108.30
12"	12	14	89.82
12"	12	12	124.50
12"	12	10	159.60

CUADRADO

DIMENSIÓN		PESO APROX.		
pulg.	mm.	kg x mt	kg x pz 6.1 mts	
3/8	9.5	.712	4.34	CARAMELO
1/2	12.7	1.266	7.72	CARAMELO
5/8	15.9	1.978	12.07	CARAMELO
3/4	19.1	2.849	17.38	
1	25.4	5.065	30.90	
1 1/4	31.8	7.913	48.27	
1 1/2	38.1	11.395	69.51	
2	50.8	10.120	61.80	

CANAL C.P.S

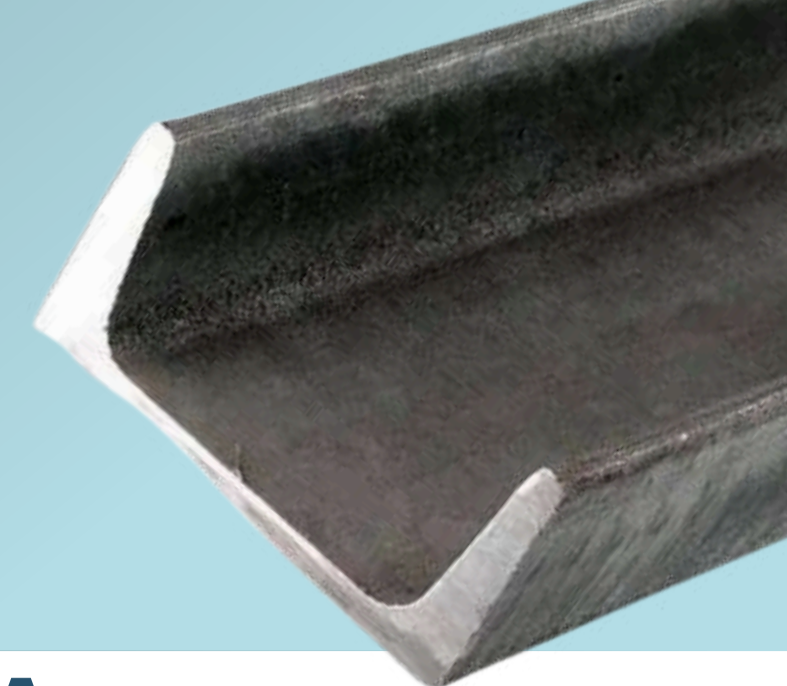

ALTURA Ó PERALTE		PESO (aprox)		PATÍN (mm)		ALMA (mm)
<i>pulg.</i>	<i>mm.</i>	<i>lb/ft</i>	<i>kg/mt</i>	<i>ancho</i>	<i>espesor</i>	
3"	76.2	4.1	6.10	35.8	7	4
4"	101.6	5.4	8.04	40.2	8	5
5"	127.0	6.7	9.96	44.4	6	4
6"	152.4	8.2	12.20	48.7	9	5
6"	152.4	10.5	15.63	51.5	9	8
6"	152.4	13.0	19.36	55.0	9	11
8"	203.8	11.5	17.11	57.4	10	6
8"	203.8	13.8	20.48	60.0	10	8
8"	203.8	18.8	27.93	64.0	10	12
10"	254.0	15.3	22.80	66.1	11	6
10"	254.0	20.0	29.80	69.8	11	10
10"	254.0	25.0	37.20	73.3	11	13
10"	254.0	30.0	44.70	77.1	11	17
12"	304.8	20.7	30.80	74.3	11	7
12"	304.8	25.0	37.20	77.4	11	10
12"	304.8	30.0	44.70	80.6	11	13
15"	381.0	33.9	50.60	85.7	11	10
15"	381.0	40.0	59.53	88.9	11	13
15"	381.0	50.0	74.41	90.4	12	18

¡Comprometidos con brindarle calidad y un buen servicio!

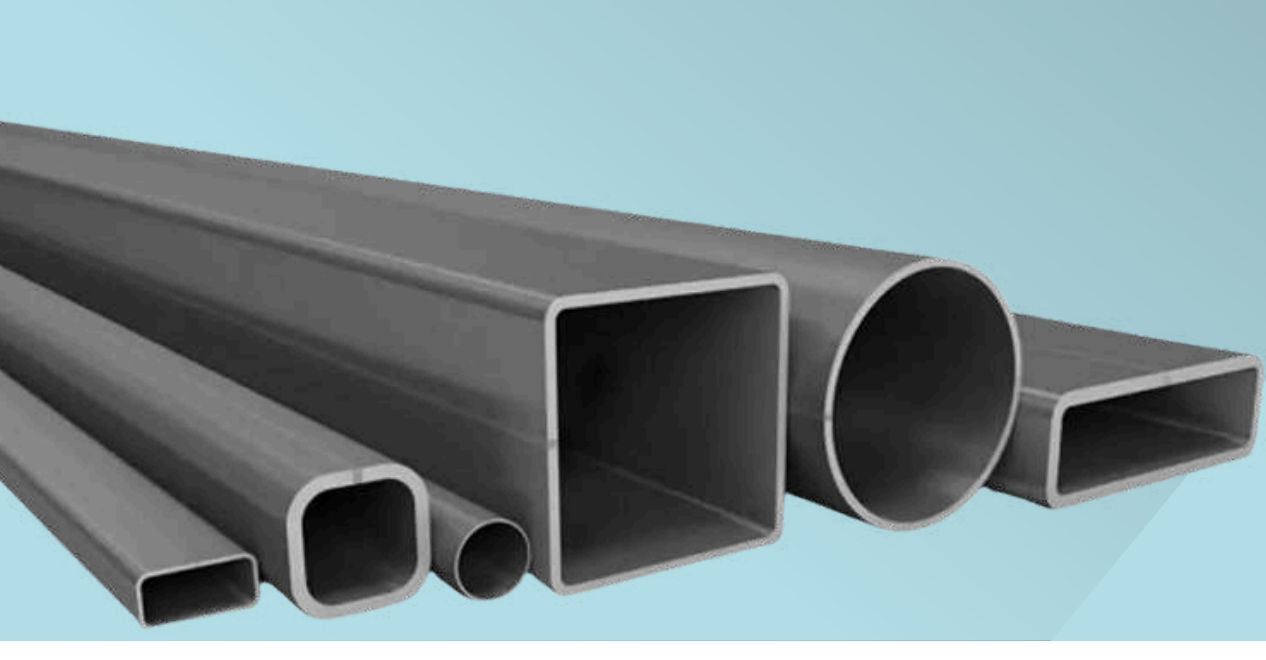

HSS

(HOLLOW STRUCTURAL SECTION)
CUADRADO

PULGADAS	1/8"	3/16"	1/4"	5/16"	3/8"	1/2"	5/8"	3/4"
4" x 4"	117.24	171.04	221.67	269.25	313.54	392.72		
5" x 5"	147.99	217.28	283.65	346.36	406.14	516.18		
6" x 6"		263.76	345.26	423.71	498.86	639.77	769.82	
8" x 8"		356.36	468.72	578.04	684.30	886.94	1078.48	
10" x 10"		448.96	592.43	732.61	869.62	1133.99	1388.36	1666.03
12" x 12"		541.80	715.90	887.06	1054.81	1381.04	1697.02	2036.42
14" x 14"				1041.39	1240.25	1628.21	2035.26	2366.80
16" x 16"				1195.60	1425.57	1875.51	2306.00	2732.80
18" x 18"						2123.00	2623.00	3099.00
20" x 20"						2367.00	2928.00	3477.00

Peso por pieza de 12.20 mts

HSS

(HOLLOW STRUCTURAL SECTION) RECTANGULAR

PULG.	1/8"	3/16"	1/4"	5/16"	3/8"	1/2"	5/8"
5" x 3"	117.24	171.04	221.67	269.25	313.54	392.72	
5" x 4"	132.49	194.22	252.54	307.93	359.90	454.45	
6" x 2"	117.24	171.04	221.77	269.25	313.54	392.72	
6" x 3"	132.49	194.22	252.54	307.93	359.90	454.45	
6" x 4"	147.99	217.28	283.65	346.36	406.14	516.18	
6" x 5"		240.58	314.39	385.03	452.62	578.28	
8" x 3"		240.58	314.39	385.03	452.62	578.28	
8" x 4"		263.76	345.26	423.71	498.86	639.77	
8" x 6"		310.12	406.99	500.93	591.46	763.48	
10" x 4"		310.12	406.99	500.93	591.46	763.48	
10" x 6"		356.36	468.72	578.04	684.30	886.94	1078.48
10" x 8"		402.72	530.70	655.38	776.90	1010.53	1233.42
12" x 4"		356.36	468.72	578.04	684.30	886.94	
12" x 6"		402.72	530.70	655.38	776.90	1010.53	1233.42
12" x 8"		448.96	592.43	732.61	869.62	1133.99	1388.36
12" x 10"			658.80	806.42	960.14	1257.82	1572.28
14" x 6"		448.96	592.43	732.61	869.62	1133.99	1388.36
14" x 10"		541.80	715.90	887.06	1054.81	1381.04	1697.02
16" x 4"		448.96	592.43	732.61	869.62	1133.99	1388.36
16" x 8"		541.80	715.90	887.06	1054.81	1381.04	1697.02
16" x 12"				1041.39	1240.25	1628.21	2035.26
18" x 4"			658.80	806.42	960.14	1257.82	
18" x 6"		541.80	715.90	887.06	1054.81	1381.04	1697.02

Peso por pieza de 12.20 mts

LÁMINA Y PLACA

ANTIDERRAPANTE

CALIBRE	ESPESOR		PESO APROX. HOJA			
	<i>Pulgadas</i>	<i>mm.</i>	<i>3' x 8'</i>	<i>3' x 10'</i>	<i>4' x 8'</i>	<i>4' x 10'</i>
10	.134"	3.42	61.24	76.54	81.66	102.06
11	.119"	3.04	54.43	68.04	72.57	90.72
12	.104"	2.66	47.63	59.53	63.50	79.38
13	.089"	2.28	40.82	51.03	54.43	68.04
14	.074"	1.91	34.19	42.52	45.36	56.67
1/8"	.125"	3.17	59.91	71.14	74.80	93.60
3/16"	.187"	4.76	85.36	106.71	113.81	142.26
1/4"	.250"	6.35	113.80	142.26	151.70	189.60

LÁMINA GALVANIZADA LISA EN HOJA

CAL	ESPESOR		KG/M			PESO APROX. HOJA			
	<i>Pulg.</i>	<i>mm</i>	<i>3'</i>	<i>4'</i>	<i>3'x6'</i>	<i>3'x8'</i>	<i>3'x10'</i>	<i>4'x8'</i>	<i>4'x10'</i>
10	.1360	3.454	24.77	33.80	45.33	60.44	75.55	83	103
12	.1061	2.695	19.32	25.76	35.36	47.14	58.93	62.85	78.57
14	.0762	1.936	13.87	18.50	25.38	33.84	42.30	45.14	56.33
16	.0613	1.557	11.15	14.87	20.40	27.21	34.01	36.28	45.35
18	.0493	1.252	8.97	11.96	16.42	21.89	27.36	29.18	36.48
20	.0374	.950	6.80	9.06	12.44	16.59	20.74	22.11	27.63
22	.0314	.798	5.70	7.60	10.43	13.91	17.39	18.54	23.18
24	.0224	.569	4.06	5.42	8.32	11.10	13.88	14.81	18.51
26	.0194	.493	3.52	4.69	6.44	8.59	10.74	11.44	14.30
28	.0164	.417	2.97	3.96	5.44	7.25	9.06	9.66	12.08
30	.0135	.343	2.44		4.47	5.95	7.44		

LÁMINA GALVANIZADA PINTADA ACANALADA

- LOSACERO
- R-100
- KR-18

Fabricación en medidas especiales. Consulte con su ejecutivo las especificaciones que usted requiere.

CALIBRE	ESPESOR		PESO APROX. HOJA			
	<i>Pulgadas</i>	<i>mm.</i>	<i>3' x 8'</i>	<i>3' x 10'</i>	<i>4' x 8'</i>	<i>4' x 10'</i>
10	.134"	3.42	61.24	76.54	81.66	102.06
11	.119"	3.04	54.43	68.04	72.57	90.72
12	.104"	2.66	47.63	59.53	63.50	79.38
13	.089"	2.28	40.82	51.03	54.43	68.04
14	.074"	1.91	34.19	42.52	45.36	56.67
1/8"	.125"	3.17	59.91	71.14	74.80	93.60
3/16"	.187"	4.76	85.36	106.71	113.81	142.26
1/4"	.250"	6.35	113.80	142.26	151.70	189.60

LÁMINA GALVANIZADA

LISA EN HOJA

CAL	ESPESOR		KG/M			PESO APROX. HOJA			
	<i>Pulg.</i>	<i>mm</i>	<i>3'</i>	<i>4'</i>	<i>3'x6'</i>	<i>3'x8'</i>	<i>3'x10'</i>	<i>4'x8'</i>	<i>4'x10'</i>
10	.1360	3.454	24.77	33.80	45.33	60.44	75.55	83	103
12	.1061	2.695	19.32	25.76	35.36	47.14	58.93	62.85	78.57
14	.0762	1.936	13.87	18.50	25.38	33.84	42.30	45.14	56.33
16	.0613	1.557	11.15	14.87	20.40	27.21	34.01	36.28	45.35
18	.0493	1.252	8.97	11.96	16.42	21.89	27.36	29.18	36.48
20	.0374	.950	6.80	9.06	12.44	16.59	20.74	22.11	27.63
22	.0314	.798	5.70	7.60	10.43	13.91	17.39	18.54	23.18
24	.0224	.569	4.06	5.42	8.32	11.10	13.88	14.81	18.51
26	.0194	.493	3.52	4.69	6.44	8.59	10.74	11.44	14.30
28	.0164	.417	2.97	3.96	5.44	7.25	9.06	9.66	12.08
30	.0135	.343	2.44		4.47	5.95	7.44		

LÁMINA GALVANIZADA

PINTADA ACANALADA

● LOSACERO

● R-100

● KR-18

Fabricación en medidas especiales. Consulte con su ejecutivo las especificaciones que usted requiere.

PLACA DE

ACERO EN HOJA

ESPESOR	Pulgadas	2"	11/2"	1 1/4"	1"	7/8"	3/4"	5/8"	1/2"	3/8"	5/16"	1/4"	3/16"
	kg/m²	50.8	38.1	31.8	25.4	22.2	149.94	124.82	99.7	74.58	62.01	50.24	37.68
PESO APROX.	Milímetros	398.78	299.08	249.63	199.39	174.27	19.1	15.9	12.7	9.5	7.9	6.4	4.8

MEDIDAS

pies	metros												
3 x 8	0.914 x 2.44	889	667	557	445	389	334	278	222	167	139	112	84
3 x 10	.914 x 3.05	1,112	834	696	556	486	418	348	278	208	173	140	104
4 X 8	1.22 X 2.44	1,187	890	743	594	519	446	372	297	222	185	150	112
4 X 10	1.22 X 3.05	1,484	1,113	929	742	648	558	464	371	278	231	187	140
5 X 20	1.52 X 6.10	3,697	2,773	2,315	1,849	1,616	1,390	1,157	924	694	578	466	349
6 X 20	1.83 X 6.10	4,452	3,339	2,787	2,226	1,945	1,674	1,393	1,113	833	694	561	420
8 X 20	2.44 X 6.10	5,935	4,452	3,715	2,968	2,594	2,232	1,858	1,484	1,110	923	748	552



LÁMINA NEGRA EN HOJA

ROLADA EN CALIENTE Y FRÍO

CAL	ESPESOR		3' x 8'	3' x 10'	4' x 8'	4' x 10'	Peso kg/m ²
	Pulg.	mm					
10	.1345	3.42	61.234	76.542	81.646	102.058	27.46
1/8"	.125	3.17	56.911	71.140	75.866	94.832	25.53
11	.1196	3.04	54.432	68.040	72.574	90.718	24.41
12	.1046	2.66	47.628	59.535	63.503	79.373	21.36
13	.0897	2.28	40.824	51.030	54.431	68.039	18.30
14	.0747	1.91	34.020	42.525	45.359	56.699	15.25
15	.0673	1.71	30.617	38.271	40.823	51.029	13.73
16	.0598	1.52	27.216	34.020	36.287	45.359	12.20
17	.0538	1.37	24.494	30.618	32.659	40.823	10.98
18	.0478	1.21	21.773	27.216	29.030	36.287	9.76
19	.0418	1.06	19.051	23.814	25.401	31.751	8.54
20	.0359	.91	16.330	20.412	21.772	27.215	7.32
21	.0329	.84	14.969	18.711	19.958	24.947	6.71
22	.0299	.76	13.608	17.010	18.144	22.680	6.10
23	.0269	.68	12.247	15.309	16.326	20.412	5.49
24	.0239	.61	10.886	13.608	14.515	18.144	4.88
25	.0209	.53	9.526	11.907	12.701	15.876	4.27
26	.0179	.45	8.165	10.206	10.886	13.608	3.66

MALLA ELECTROSOLDADA

DISEÑO	ANCHO (m)	LARGO (m)	PESO APROX. (por rollo)
66 - 44	2.50	40	2.71
64 - 66	2.50	40	1.98
66 - 88	2.50	40	1.41
66 - 1010	2.50	40	.98

Nuestra prioridad, es la satisfacción de nuestros clientes

TERNIUM ZINTRO	R.PYTSA PINTADO	PESO APROXIMADO	
		CAL	KG / PZ
ZV131	101	20	3.600
ZV120	104	20	5.800
ZV120	104	18	7.500
ZM225	112	20	5.600
ZM350	113	20	6.400
ZV154	114	20	1.100
ZV154	114	18	1.500
ZV155	117	20	1.650
ZC100	121	20	4.300
ZC100	121	18	5.600
ZP1400	127	18	7.300
ZD170	132	20	9.500
ZM138	139	20	5.200
ZM138	139	18	6.800
ZM525	145	20	8.700
ZM525	145	18	11.50
ZM600	146	20	9.400
ZM600	146	18	12.400
ZV101	201	20	5.600
ZV101	201	18	7.400
ZV121	204	20	5.800
ZV121	204	18	7.600
ZV123	205	20	6.500
ZV123	205	18	8.500
ZV122	206	20	5.800
ZV122	206	18	7.600
ZC150	207	20	6.600
ZC150	207	18	8.700

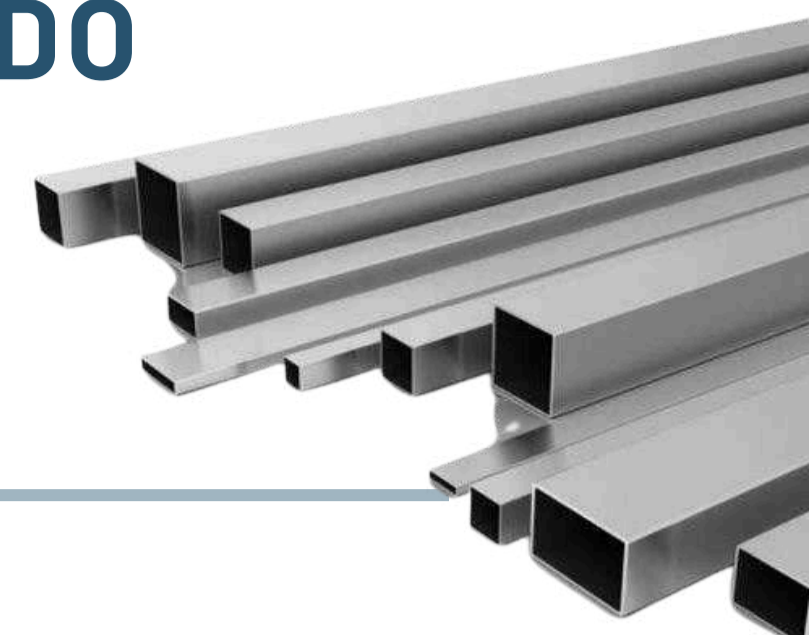

PERFIL TUBULAR PINTADO Y ZINTRO

TERNIUM <i>ZINTRO</i>	R.PYTSA <i>PINTADO</i>	PESO APROXIMADO	
		<i>CAL</i>	<i>KG / PZ</i>
ZC150	207	16	10.650
ZC150	207	14	13.100
ZC125	208	20	5.400
ZC125	208	18	7.200
ZC125	208	16	8.800
ZC125	208	14	10.700
ZR225	209	20	6.600
ZR225	209	18	8.700
ZC075	210	20	3.150
ZC075	210	18	4.200
ZV124	211	18	3.900
ZC050	212	20	2.200
ZC050	212	18	2.800
ZR100	215	20	3.150
ZR100	215	18	4.200
ZR200	216	20	6.500
ZR200	216	18	8.700
ZR200	216	14	13.100
ZV103	219	20	6.600
ZV103	219	18	8.700
ZV144	224	20	7.000
TH150	225	20	6.600
TH150	225	18	8.700
ZP1500	227	14	17.630
ZP1500	227	16	14.250
ZR125	228	18	5.600
ZR125	228	20	4.300

TERNIUM <i>ZINTRO</i>	R.PY TSA <i>PINTADO</i>	PESO APROXIMADO	
		<i>CAL</i>	<i>KG / PZ</i>
ZR175	230	20	5.40
ZR175	230	18	7.20
ZV106	233	20	6.60
ZV106	233	18	8.70
ZP150	234	20	7.45
ZP150	234	18	9.70
ZP015	235	18	11.26
ZP015	235	20	8.50
ZP100	236	20	6.10
ZP100	236	18	8.00
ZP150	237	18	9.00
ZP150	237	20	7.00
ZP150	238	18	12.60
ZP020	238	20	9.30
ZR249	241	20	8.00
ZR243	241	18	10.50
ZV127	242	20	8.50
ZV127	242	18	11.20
ZV126	243	20	7.80
ZV126	243	18	10.20
ZP200	261	20	8.20
ZP200	261	18	10.80
ZP250	268	20	9.30
ZP250	268	18	12.00
ZC200	307	18	11.50
ZC200	307	16	14.30

TERNIUM ZINTRO	R.PYTSA PINTADO	PESO APROXIMADO	
		CAL	KG / PZ
ZC200	307	14	17.70
ZP300	310	20	10.50
ZP300	310	18	13.80
ZR300	322	20	9.60
ZR300	322	18	12.70
ZR300	322	16	15.60
ZR300	322	14	19.20
ZR250	368	20	8.50
ZP250	368	18	11.20
ZP400	410	20	12.70
ZR400	410	18	16.80
ZR400	422	20	11.80
ZR400	422	18	15.60
ZR400	422	16	19.30
ZR400	422	14	23.80

P.T.R

Los pesos teóricos, son calculados según las especificaciones del fabricante de lámina.

Dimensión Pulg.	mm	Cal.	Color	Espesor	Peso aprox.
				(mm)	Kg/Pz 6.00 mts
3/4 x 3/4	25.4 x 25.4	14	Azul	1.89	8.65
		14	Azul	1.90	8.76
1 x 1	25.4 x 25.4	12	Verde	2.66	11.22
		10	Rojo	3.42	13.62
1 1/4 x 1 1/4	31.7 x 31.7	14	azul	1.89	10.70
		14	Azul	1.89	13.10
1 1/2 x 1 1/2	38.1 x 38.1	12	Blanco	2.66	17.76
		11	Verde	3.04	19.98
		9	Rojo	3.80	24.12

P.T R

Dimensión		Cal.	Color	Espesor (mm)	Peso aprox. Kg/Pz 6.00 mts
Pulg.	mm				
2x1	50.8x25.4	14	Azul	1.89	13.00
2x2	50.8x50.8	14	Azul	1.89	17.70
		12	Blanco	2.66	24.30
		11	Verde	3.04	27.30
		9	Rojo	3.80	33.36
2 1/2x1 1/4	63.3x31.7	14	Azul	1.89	15.85
2 1/2x1 1/2	63.5x38.1	14	Azul	1.89	18.00
2 1/2x2 1/2	63.5x63.5	14	Azul	1.89	22.19
		11	Blanco	3.04	34.92
		9	Verde	3.80	42.78
		7	Rojo	4.55	50.22
3x1 1/2	76.2x38.1	14	Azul	1.89	19.00
3x3	76.2x76.2	14	Azul	1.89	27.59
		11	Blanco	3.04	42.54
		9	Verde	3.8	52.32
		7	Rojo	4.55	61.68
3 1/2x3 1/2	88.9x88.9	14	Azul	1.89	31.65
		11	Blanco	3.04	50.04
		9	Verde	3.80	61.68
		7	Rojo	4.55	72.96
3 x 2	76.2x50.8	14	Azul	1.89	22.14
		11	Blanco	3.04	34.92
		9	Verde	3.80	42.78
		7	Rojo	4.55	50.22
4x1 1/2	101.6x38.1	14	azul	1.89	25.00
4 x 2	101.6x50.8	14	Azul	1.89	27.59
		11	Blanco	3.04	42.54
		9	Verde	3.80	52.32
		7	Rojo	4.55	61.68

P.T.R

Dimensión		Cal.	Color	Espesor (mm)	Peso aprox. Kg/Pz 6.00 mts
Pulg	mm				
4 x 3	101.6 x 76.2	14	Azul	1.89	31.65
		11	Blanco	3.04	50.04
		9	Verde	3.80	61.68
		7	Rojo	4.55	72.96
4 x 4	101.6 x 101.6	14	Azul	1.89	36.20
		11	Blanco	3.04	57.60
		9	Verde	3.80	72.18
		7	Rojo	4.55	85.80

Todos nuestros materiales se resguardan bajo techo para asegurar su calidad y conservación

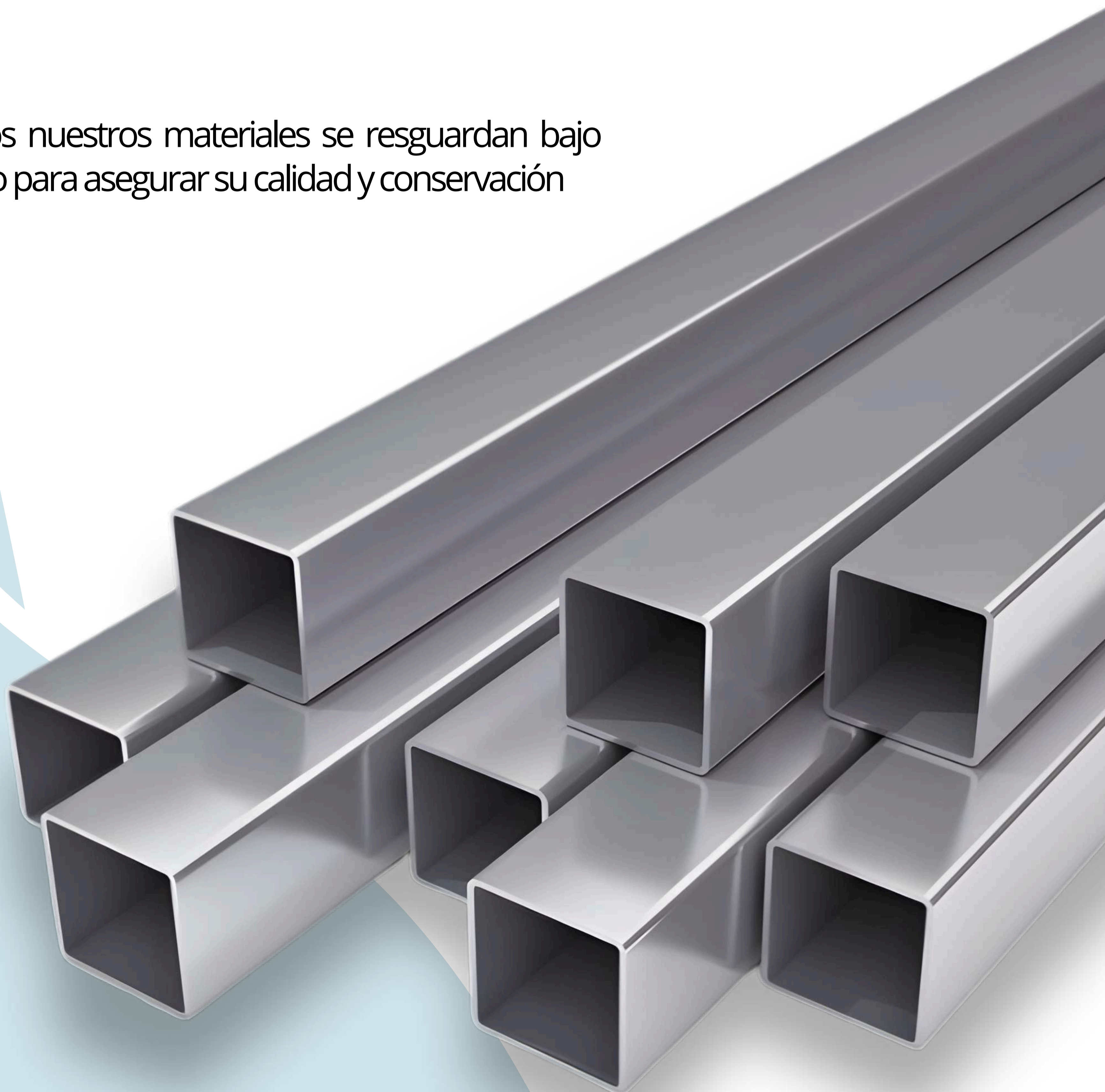

REDONDO

Pulg.	mm	Peso aprox. Kg/Pz	kilos por Piezas 6.10mts
3/8	9.5	0.559	3.41
7/16	11.1	0.760	4.64
1/2	12.7	0.994	6.06
5/8	15.9	1.552	9.47
3/4	19.1	2.235	13.63
7/8	22.2	3.042	18.56
15/16	23.8	3.493	21.31
1	25.4	3.974	24.24
1 1/8	28.6	5.029	30.68
1 1/4	31.8	6.211	37.89
1 3/8	34.9	7.552	46.07
1 1/2	38.1	9.000	54.90
1 3/4	44.5	12.170	74.24
2	50.8	15.900	96.99
2 1/4	57.1	17.970	122.73
2 1/2	63.5	24.850	151.52

SOLERA



Pulgadas	Milímetros	Peso aprox. Kg/metro	Peso aprox. Pza a 6.10
1/2	3.2 x	12.7	1.95
5/8		15.9	2.37
3/4		19.1	2.92
1		25.4	3.84
1 1/4		31.7	4.81
1 1/2		38.1	5.79
2		50.8	7.74
2 1/2		63.5	9.69
3		76.2	11.59

Materiales con entrega a domicilio, tu obra ó taller consulte con su ejecutivo

SOLERA

Pulgadas

Milímetros

Peso aprox.

Peso aprox.

Kg / metro

Pza a 6.10

Pulgadas	Milímetros	Peso aprox. Kg / metro	Peso aprox. Pza a 6.10	
3/16 x	1/2	12.7	0.47	2.86
	5/8	15.9	0.59	3.59
	3/4	19.1	0.71	4.33
	1	25.4	0.95	5.79
	1 1/4	31.7	1.18	7.19
	1 1/2	38.1	1.42	8.66
	2	50.8	1.9	11.59
	2 1/2	63.5	2.37	14.45
	3	76.2	2.85	17.38

Pulgadas	Milímetros	Peso aprox. Kg / metro	Peso aprox. Pza a 6.10	
1/4 x	1/2	12.7	0.63	3.84
	3/4	19.1	0.95	5.79
	1	25.4	1.27	7.74
	1 1/4	31.7	1.52	9.27
	1 1/2	38.1	1.9	11.59
	2	50.8	2.53	15.43
	2 1/2	63.5	3.16	19.27
	3	76.2	3.79	23.11
	4	101.6	5.06	30.86
	5	127.0	6.33	38.61
	6	152.4	7.59	46.29

Pulgadas	Milímetros	Peso aprox. Kg / metro	Peso aprox. Pza a 6.10	
5/16 x	1 1/2	38.1	2.37	14.45
	2	50.8	3.16	19.27
	2 1/2	63.5	3.95	24.09
	3	76.2	4.75	28.97
	4	101.6	6.33	38.61
	5	127.0	7.91	48.25
	6	152.4	9.49	57.88

Pulgadas	Milímetros	Peso aprox. Kg / metro	Peso aprox. Pza a 6.10	
3/8 x	1	25.4	1.89	12.07
	1 1/4	31.7	2.37	14.45
	1 1/2	38.1	2.85	17.38
	2	50.8	3.80	23.18
	2 1/2	63.5	4.75	28.89
	3	76.2	5.69	34.70
	4	101.6	7.59	46.29
	5	127	9.49	57.88
	6	152.4	11.39	69.47
8	203.2	15.40	93.94	

SOLERA

Pulgadas

Milímetros

Peso aprox.
Kg/metro

Peso aprox.
Pza a 6.10

Pulgadas	Milímetros	Peso aprox. Kg/metro	Peso aprox. Pza a 6.10
1/2 x	1	25.4	15.43
	1 1/4	31.7	19.27
	1 1/2	38.1	23.18
	2	50.8	30.86
	2 1/2	63.5	38.61
	3	76.2	46.29
	4	101.6	61.79
	5	127	77.16
	6	152.4	92.65
8	203.2	125.53	

12.7 x

Pulgadas	Milímetros	Peso aprox. Kg/metro	Peso aprox. Pza a 6.10
5/8 x	1 1/2	38.1	28.91
	2	50.8	38.61
	2 1/2	63.5	48.25
	3	76.2	57.88
	4	101.6	77.16
	5	127.0	96.50
	6	152.4	115.83
	8	203.2	154.51

15.9 x

Pulgadas	Milímetros	Peso aprox. Kg/metro	Peso aprox. Pza a 6.10
3/4 x	1 1/2	38.1	34.77
	2	50.8	46.29
	2 1/2	63.5	57.88
	3	76.2	69.47
	4	101.6	92.65
	5	127.0	115.90
	6	152.4	139.01
	8	203.2	185.62
	10	254.0	231.67

19.1 x

Pulgadas	Milímetros	Peso aprox. Kg/metro	Peso aprox. Pza a 6.10
1 x	2	50.8	61.73
	2 1/2	63.5	77.22
	3	76.2	92.65
	4	101.6	123.52
	5	127.0	154.45
	6	152.4	185.31
	8	203.2	247.11
	10	254.0	308.90

25.4 x

TABLERO PINTADO

Y ZINTRO

Ancho		Largo		Calibre	Peso aprox. Kg / pieza
<i>pies</i>	<i>mts</i>	<i>pies</i>	<i>mts</i>		
3	(0.91)	3	(0.91)	20	6.06
3	(0.91)	4	(1.22)	20	8.01
3	(0.91)	6	(1.83)	20	12.12
3	(0.91)	8	(2.44)	20	16.18
3	(0.91)	10	(3.05)	20	20.21
4	(1.22)	3	(0.91)	20	8.08
4	(1.22)	4	(1.22)	20	10.78
4	(1.22)	6	(1.83)	20	16.17
4	(1.22)	8	(2.44)	20	21.56
4	(1.22)	10	(3.05)	20	26.95
3	(0.91)	3	(0.91)	22	5.05
3	(0.91)	4	(1.22)	22	6.74
3	(0.91)	6	(1.83)	22	10.10
3	(0.91)	8	(2.44)	22	13.47
3	(0.91)	10	(3.05)	22	16.84
4	(1.22)	3	(0.91)	22	6.74
4	(1.22)	4	(1.22)	22	8.98
4	(1.22)	6	(1.83)	22	13.48
4	(1.22)	8	(2.44)	22	17.97
4	(1.22)	10	(3.05)	22	22.46

TUBERÍA GALVANIZADA Y NEGRA CÉDULA 40

Diámetro nominal		Diámetro exterior mm	Espesor milímetros	Peso aprox. Kg / pieza
<i>pulgadas</i>	<i>milímetros</i>			
1/2"	12.7	21.3	2.77	8.13
3/4"	19.1	26.7	2.87	10.82
1"	25.4	33.4	3.38	16.00
1 1/4"	31.8	42.2	3.56	21.70
1 1/2"	38.1	48.3	3.68	25.92
2"	50.8	60.3	3.91	34.82
2 1/2"	63.5	73.0	5.16	55.23
3"	76.2	88.9	5.49	72.26
4"	101.6	114.3	6.08	102.85

○ *Tubería en tramos de 6.4 metros.*

TUBERÍA NEGRA CÉDULA 30

Diámetro nominal		Cal	Diámetro exterior mm	Espesor milímetros	Peso aprox. Kg / pieza
pulgadas	milímetros				
1/2"	12.7	14	21.3	1.90	5.56
3/4"	19.1	14	26.7	1.90	6.78
1"	25.4	14	33.4	1.90	9.00
1 1/4"	31.8	13	42.2	2.29	14.10
1 1/2"	38.1	13	48.3	2.29	16.20
2"	50.8	12	60.3	2.67	23.70
2 1/2"	63.5	12	73.0	2.67	27.78
3"	76.2	11	88.9	3.05	40.20
4"	101.6	11	114.3	3.05	52.20

◦ Tubería en tramos de 6.00 metros.

TUBERÍA ESTRUCTURAL

Diámetro nominal	Ext mm	Espesor de pared			Cédula	Peso aprox.		
		Fracc. pulg.	Milésima pulg.	mm.		lb / pie	kg / m	
6"	6 5/8"	168.3	3/16"	0.188"	4.78	40	12.92	19.35
			7/32"	0.219"	5.60	40	14.98	22.47
			1/4"	0.250"	6.35	40	17.02	25.55
			9/32"	0.280"	7.10	40	18.97	28.22
			3/8"	0.375"	9.50	40	24.99	37.20
8"	8 5/8"	219.1	3/16"	0.188"	4.78	10	16.94	25.37
			7/32"	0.219"	5.60	20	19.66	29.48
			1/4"	0.250"	6.35	20	22.36	33.57
			5/16"	0.312"	7.90	30	27.7	41.14
				0.322"	8.20	40	28.55	42.65
			3/8"	0.375"	9.50	40	33.04	49.10
			1/2"	0.500"	12.70	80	43.99	65.47
			3/16"	0.188"	4.78	10	21.21	31.76
	7/32"	0.219"	5.60	10	24.63	36.94		
	0.225"	5.72	10	24.66	36.69			

Diámetro		Ext	Espesor de pared			Cédula	Peso aprox.	
			Fracc.	Milésima			lb/pie	kg/m
nominal	pulg	mm	pulg.	pulg.	mm.			
10"	10 3/4"	273.1	1/4"	0.250"	6.35	20	28.04	42.09
			0.307"	7.80	30	34.24	51.03	
			0.365"	9.27	40	40.48	60.50	
			3/8"	0.375"	9.50	40	41.1	61.16
			1/2"	0.500"	12.70	60	54.8	81.55
12"	12 3/4"	323.9	3/16"	0.188"	4.78	10	25.22	37.77
			7/32"	0.219"	5.60	10	29.31	43.96
			1/4"	0.225"	5.72	10	30.30	45.09
			3/8"	0.250"	6.35	20	33.38	50.11
			13/32"	0.375"	9.50	ced.std.	49.56	73.65
			2	0.406"	10.30	40	53.52	79.65
			0.210"	5.30	10	30.93	45.78	
14"	14"	355.6	0.225"	5.72	10	32.68	48.63	
			1/4"	0.250"	6.35	10	36.71	55.11
			5/16"	0.312"	7.90	20	45.61	67.74
			3/8"	0.375"	9.50	30	54.57	81.04
			0.438"	11.10	40	63.44	94.30	
			0.465"	11.81	40	67.87	101.00	
			1/2"	0.500"	12.70	ext.fte.	72.09	107.39
16"	16"	406.4	7/32"	0.219"	5.60	10	36.91	55.35
			0.225"	5.72	10	37.28	55.48	
			1/4"	0.250"	6.35	10	42.05	63.13
			0.281"	7.14	20	47.17	69.91	
			5/16"	0.312"	7.90	20	52.27	77.63
			3/8"	0.375"	9.50	30	62.58	92.98
			1/2"	0.500"	12.70	40	82.77	123.30
18"	18"	457.2	1/4"	0.250"	6.35	10	47.39	71.12
			5/16"	0.312"	7.90	20	58.94	87.49
			3/8"	0.375"	9.50	ced std	70.59	104.84
			1/2"	0.500"	12.70	ext fte	93.45	139.15

Diámetro nominal	pulg	Ext mm	Espesor de pared			Peso aprox.		
			Fracc. pulg.	Milésima pulg.	Cédula mm.	lb/pie	kg/m	
20"	20"	508.0	1/4"	0.250"	6.35	10	52.73	79.16
			5/16"	0.312"	7.90	20	65.6	97.43
			3/8"	0.375"	9.50	20	78.6	116.78
			1/2"	0.500"	12.70	30	104.13	155.12
24"	24"	609.6	1/4"	0.250"	6.35	10	63.41	95.26
			3/8"	0.375"	9.50	20	94.62	140.68
			1/2"	0.500"	12.70	ext fte	125.49	187.06
30"	30"	762.0	1/4"	0.250"	6.35	5	79.43	119.25
			3/8"	0.375"	9.50	ced std	118.65	176.29
			1/2"	0.500"	12.70	ext fte	157.53	234.67
32"	32"	812.8	1/4"	0.250"	6.35	5	84.77	127.30
			3/8"	0.375"	9.50	ced std	126.66	188.24
			1/2"	0.500"	12.70	ext fte	168.21	250.64
36"	36"	914.4	5/16"	0.312"	7.90	10	118.92	176.52
			3/8"	0.375"	9.50	ced std	142.68	211.90
			1/2"	0.500"	12.70	ext fte	189.57	282.27

VIGA I.P.S

Peralte		Patín	alma	Peso aprox
Pulg.	mm	ancho mm	mm	kg/mts
3	76.2	59.23	4.3	8.48
4	101.6	67.64	4.9	11.46
5	127.0	76.30	5.4	14.88
6	152.4	84.63	5.9	18.60
8	200.0	89.99	7.5	26.19



Número	Pulgada	Milímetro	Kg x pieza
2.5	5/16	7.9	0.384
3	3/8	9.5	0.560
4	1/2	12.7	0.994
5	5/8	15.9	1.552
6	3/4	19.1	2.235
8	1	25.4	3.973
10	1 1/4	31.8	6.225
12	1 1/2	38.1	8.938

Nota: Número corresponde al número de octavos de pulgadas equivalente al diámetro nominal de la varilla.

VIGA I.P.R

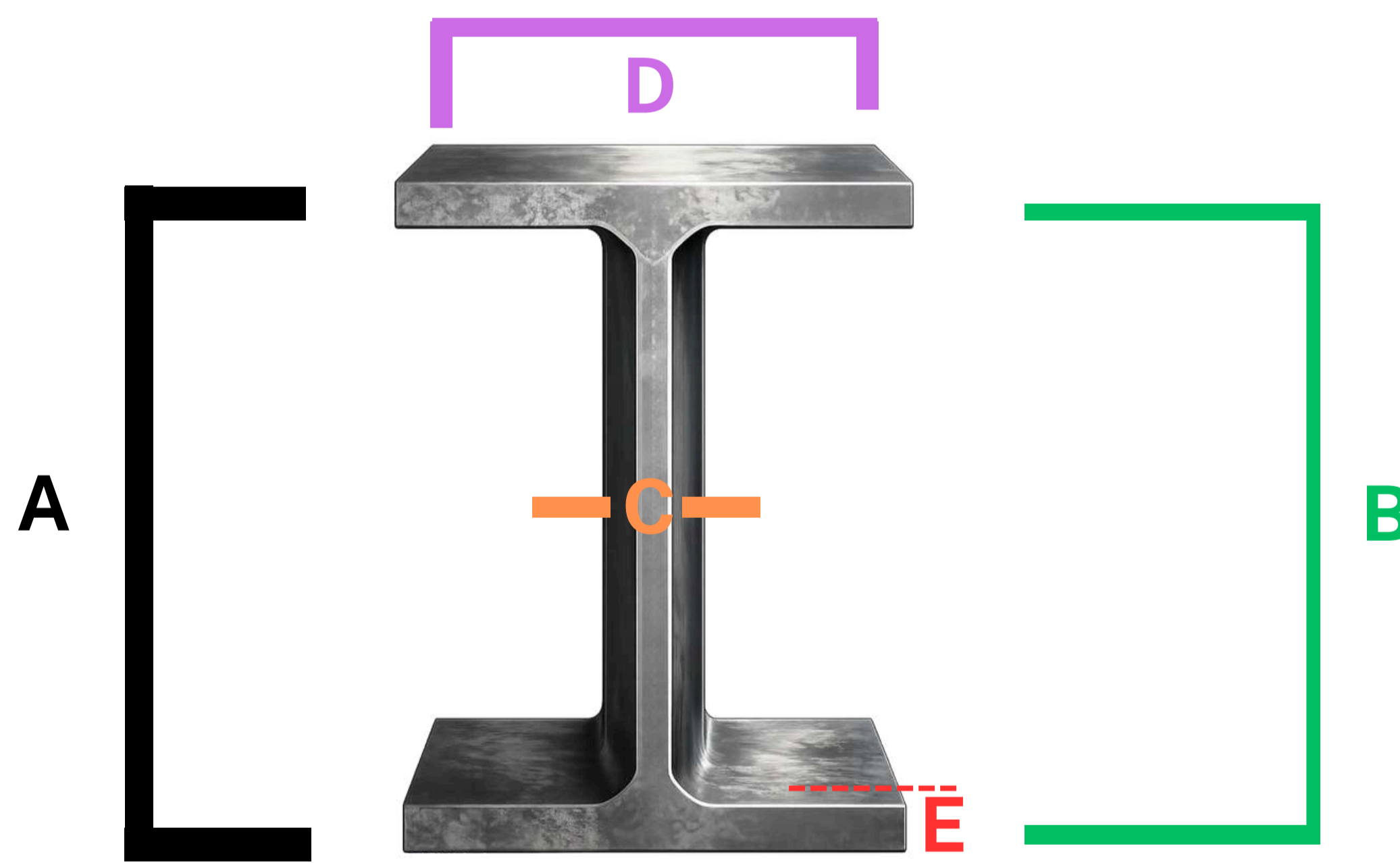

- A** Peralte exterior
- B** Peralte interior
- C** Alma
- D** Ancho de patín
- E** Espesor de patín

VIGA I.P.R.

Dimensión <i>pulgadas</i>	Peso aprox		Peralte ext. (A)	Peralte int. (B)	Alma (C)	Ancho patín (D)	Espesor patín (E)
	<i>lf / ft</i>	<i>kg/m</i>					
4x4	13	19.3	106	88	7.1	103	8.8
5x5	16	23.8	127	109	6.1	127	9.1
5x5	19	28.3	131	109	6.9	128	10.9
6x4	8.5	12.6	152	140	4.5	100	4.6
6x4	9	13.5	150	139	4.3	100	5.5
6x4	12	17.9	153	138	5.8	102	7.1
6x4	16	23.8	160	139	6.6	102	10.3
6x6	15	22.3	152	139	5.8	152	6.6
6x6	20	29.8	157	138	6.6	153	9.3
6x6	25	37.2	162	139	8.1	154	11.6
8x4	10	14.9	200	190	4.3	100	5.2
8x4	13	19.3	203	190	5.8	102	6.5
8x4	15	22.3	206	190	6.2	102	8.0
8x5 1/4"	18	26.8	207	190	5.8	133	8.4
8x5 1/4"	21	31.3	210	190	6.4	134	10.2
8x6 1/2"	24	35.7	201	181	6.2	201	10.2
8x6 1/2"	28	41.7	205	181	7.2	205	11.8
8x8	31	46.1	203	181	7.2	203	11.0
8x8	35	52.1	206	181	7.9	204	12.6
8x8	40	59.5	210	182	9.1	205	14.2
8x8	48	71.4	216	181	10.2	206	17.4
8x8	58	86.3	222	181	13	209	20.6
8x8	67	99.7	229	182	14.5	210	23.7
10x4	12	17.9	251	240	4.8	101	5.3
10x4	15	22.3	254	240	5.8	102	6.9
10x4	17	25.3	257	240	6.1	102	8.4
10x4	19	28.3	260	240	6.4	102	10.0
10x5 3/4"	22	32.7	258	240	6.1	146	9.1
10x5 3/4"	26	38.7	262	240	6.6	147	11.2
10x5 3/4"	30	44.6	266	240	7.6	147	13.0

VIGA I.P.R.

Dimensión <i>pulgadas</i>	Peso aprox <i>lf / ft</i>	<i>kg/m</i>	Peralte ext. (A)	Peralte int. (B)	Alma (C)	Ancho patín (D)	Espesor patín (E)
10x8	33	49.1	247	225	7.4	202	11
10x8	39	58	252	225	8	203	13.5
10x8	45	67	257	226	8.9	204	15.7
10x10	49	72.9	253	225	8.6	254	14.2
10x10	54	80.4	256	225	9.4	255	15.6
10x10	60	89.3	260	225	10.7	256	17.3
10x10	68	101	264	225	11.9	257	19.6
10x10	77	115	269	225	13.5	259	22.1
10x10	88	131	275	225	15.4	261	25.1
10x10	100	149	282	225	17.3	263	28.4
10x10	112	167	289	225	19.2	265	31.8
12x4	14	20.8	303	292	5.1	101	5.7
12x4	16	23.8	305	292	5.6	101	6.7
12x4	19	28.3	309	291	6	102	8.9
12x4	22	32.7	313	291	6.6	102	10.8
12x6 1/2"	26	38.7	310	291	5.8	165	9.7
12x6 1/2"	30	44.6	313	291	6.6	166	11.2
12x6 1/2"	35	52.1	317	291	7.9	167	13.2
12x8	40	59.5	303	277	7.5	203	13.1
12x8	45	67	306	277	8.5	204	14.6
12x8	50	74.4	310	277	9.4	205	16.3
12x10	53	78.9	306	277	8.8	254	14.6
12x10	58	86.3	310	277	9.1	254	16.3
12x12	65	96.7	308	277	9.9	305	15.4
12x12	72	107	311	277	10.9	306	17
12x12	79	118	314	277	11.9	307	18.7
12x12	87	129	318	277	13.1	308	20.6
12x12	96	143	323	277	14	309	22.9
12x12	106	158	327	277	15.5	310	25.1
12x12	120	179	333	277	18	313	28.1

VIGA I.P.R.

Dimensión <i>pulgadas</i>	Peso aprox		Peralte ext. (A)	Peralte int. (B)	Alma (C)	Ancho patín (D)	Espesor patín (E)
	<i>lf/ft</i>	<i>kg/m</i>					
12x12	136	202	341	277	20.1	315	31.8
12x12	152	226	348	277	22.1	317	35.6
12x12	170	253	356	277	24.4	319	39.6
12x12	190	283	365	277	26.9	322	44.1
12x12	210	313	374	277	30	325	48.3
12x12	230	342	382	277	32.6	328	52.6
12x12	252	375	392	277	36	332	58.0
12x12	279	415	400	277	38	335	64.0
12x12	336	500	405	277	42	339	74.0
14x5	22	32.7	349	332	5.8	127	8.5
14x5	26	38.7	353	332	6.5	128	10.7
14x6 3/4"	30	44.6	352	332	6.9	171	9.8
14x6 3/4"	34	50.6	355	332	7.2	171	11.6
14x6 3/4"	38	56.6	358	332	7.9	172	13.1
14x8	43	64	347	320	7.7	203	13.5
14x8	48	71.4	350	320	8.6	204	15.1
14x8	53	78.9	354	320	9.4	205	16.8
14x10	61	90.8	353	320	9.5	254	16.4
14x10	68	101	357	320	10.5	255	18.3
14x10	74	110	360	320	11.4	256	19.9
14x10	82	122	363	320	13.0	257	21.7
14x14 1/2"	90	134	356	320	11.2	369	18.0
14x14 1/2"	99	147	360	320	12.3	370	19.8
14x14 1/2"	109	162	364	320	13.3	371	21.8
14x14 1/2"	120	179	368	320	15.0	373	23.9
14x14 1/2"	132	196	372	320	16.4	374	26.2
14x16	145	216	375	320	17.3	394	27.7
14x16	159	237	380	320	18.9	395	30.2
14x16	176	262	387	320	21.1	398	33.3
14x16	193	287	393	320	22.6	399	36.6

VIGA I.P.R.

Dimensión <i>pulgadas</i>	Peso aprox <i>lf / ft</i>	<i>kg/m</i>	Peralte ext. (A)	Peralte int. (B)	Alma (C)	Ancho patín (D)	Espesor patín (E)
14 x 16	211	314	399	320	24.9	401	39.6
14 x 16	233	347	407	320	27.2	404	43.7
14 x 16	257	382	416	320	29.8	406	48.0
14 x 16	283	421	425	320	32.8	409	52.6
14 x 16	311	463	435	320	35.8	412	57.4
14 x 16	342	509	446	321	39.1	416	62.7
14 x 16	370	551	455	320	42.0	418	67.6
14 x 16	398	592	465	320	45.0	421	72.3
14 x 16	426	634	474	320	47.6	424	77.1
14 x 16	455	677	483	320	51.2	428	81.5
14 x 16	500	744	498	320	55.6	432	88.9
14 x 16	550	818	514	320	60.5	437	97.0
							
16 x 5 1/2"	26	39	399	381	6.4	140	8.8
16 x 5 1/2"	31	46	403	381	7.0	140	11.2
16 x 7	36	53.6	403	381	7.5	177	10.9
16 x 7	40	59.5	407	381	7.7	178	12.8
16 x 7	45	67	410	381	8.8	179	14.4
16 x 7	50	74.4	413	381	9.7	180	16.0
16 x 7	57	84.8	417	381	10.9	181	18.2
16 x 10 1/4"	67	100	415	381	10.0	260	16.9
16 x 10 1/4"	77	115	420	381	11.6	261	19.3
16 x 10 1/4"	89	132	425	381	13.3	263	22.2
16 x 10 1/4"	100	149	431	381	14.9	265	25.0
18 x 6	35	52.1	450	428	7.6	152	10.8
18 x 6	40	59.5	455	428	8.0	1253	13.3
18 x 6	46	68.5	459	428	9.1	154	15.3

VIGA I.P.R.

Dimensión <i>pulgadas</i>	Peso aprox		Peralte ext. (A)	Peralte int. (B)	Alma (C)	Ancho patín (D)	Espesor patín (E)
	lf / ft	kg/m					
18x7 1/2"	41	61	455	430	8.4	190	12.0
18x7 1/2"	45	67	458	432	8.7	190	12.3
18x7 1/2"	50	74.4	457	428	9.0	190	14.5
18x7 1/2"	55	81.8	460	428	9.9	191	16.0
18x7 1/2"	60	89.3	463	428	10.5	192	17.7
18x7 1/2"	65	96.7	466	428	11.4	193	19.0
18x7 1/2"	71	106	469	428	12.6	194	20.6
18X11	76	113	463	428	10.8	280	17.3
18X11	86	128	467	428	12.2	282	19.6
18X11	97	144	472	428	13.6	283	22.1
18X11	106	158	476	428	15.0	284	23.9
18X11	119	177	482	428	16.6	286	26.9
18X11	130	193	489	428	17.0	283	30.5
18X11	143	213	495	428	18.5	285	33.5
18X11	158	235	501	428	20.6	287	36.6
18X11	175	260	509	428	22.6	289	40.4
18X11	192	286	519	428	22.8	293	45.0
18X11	211	314	525	428	27	293	48.5
18X11	234	348	535	428	29	296	53.5
18X11	258	384	545	428	32	299	58.4
18X11	283	421	555	428	35	302	63.5
18X11	311	463	567	428	38	305	69.5
21X6 1/2"	44	65.5	525	502	8.9	165	11.4
21X6 1/2"	50	74.4	529	502	9.7	166	13.6
21X6 1/2"	57	84.8	535	502	10.3	166	16.5
21X8 1/4"	48	71.4	522	500	8.2	208	11.9
21X8 1/4"	55	81.8	528	501	9.7	209	13.30
21X8 1/4"	62	92.3	533	502	10.2	209	15.6
21X8 1/4"	68	101	537	502	10.9	210	17.4
21X8 1/4"	73	109	539	501	11.6	211	18.8

VIGA I.P.R.

Dimensión <i>pulgadas</i>	Peso aprox		Peralte ext. (A)	Peralte int. (B)	Alma (C)	Ancho patín (D)	Espesor patín (E)
	<i>lf / ft</i>	<i>kg/m</i>					
21 X 8 1/4"	83	124	544	502	13.1	212	21.2
21 X 8 1/4"	93	138	549	502	14.7	214	23.6
21 X 12 1/4"	101	150	543	502	12.7	312	20.3
21 X 12 1/4"	111	165	546	502	14.0	313	22.2
21 X 12 1/2"	122	182	551	502	15.2	315	24.4
21 X 12 1/2"	132	196	554	501	16.5	316	26.3
21 X 12 1/2"	147	219	560	502	18.3	318	29.2
21 X 12 1/2"	166	247	571	502	19.0	315	34.5
21 X 12 1/2"	182	271	577	502	21.1	318	37.6
21 X 12 1/2"	201	299	585	502	23.1	319	41.4
21 X 12 1/2"	223	332	593	502	25.4	322	45.4
21 X 12 1/2"	248	369	603	502	27.9	324	50.5
21 X 12 1/2"	275	409	613	502	30.9	327	55.6
24 X 7	55	81.8	599	573	10.0	178	12.8
24 X 7	62	92.3	603	573	10.9	179	15.0
24 X 9	56	83.3	599	573	9.0	228	13.0
24 X 9	61	90.8	598	573	9.6	227	12.7
24 X 9	68	101	603	573	10.5	228	14.9
24 X 9	76	113	608	573	11.2	228	17.3
24 X 9	84	125	612	573	11.9	229	19.6
24 X 9	94	140	617	573	13.1	230	22.2
24 X 9	103	153	623	573	14.0	229	24.9
24 X 12 3/4"	104	155	611	573	12.7	324	19.0
24 X 12 3/4"	117	174	616	573	14.0	325	21.6
24 X 12 3/4"	131	195	622	573	15.4	327	24.4
24 X 12 3/4"	146	217	628	573	16.5	328	27.7
24 X 12 3/4"	162	241	635	573	17.1	329	31.0
24 X 12 3/4"	176	262	641	573	19.0	327	34.0
24 X 12 3/4"	192	286	647	573	20.6	329	37.1
24 X 12 3/4"	207	308	660	573	22.0	333	39.0

VIGA I.P.R.

Dimensión <i>pulgadas</i>	Peso aprox		Peralte ext. (A)	Peralte int. (B)	Alma (C)	Ancho patín (D)	Espesor patín (E)
	lf / ft	kg/m					
24 X 12 3/4"	229	341	661	573	24.4	333	43.9
24 X 12 3/4"	250	372	670	573	26.6	335	47.5
24 X 12 3/4"	279	415	679	573	29.5	338	53.1
24 X 12 3/4"	306	455	689	573	32.0	340	57.9
24 X 12 3/4"	335	499	699	573	35.1	343	63.0
24 X 12 3/4"	370	551	711	573	38.6	347	69.1
27 X 10	84	125	678	645	11.7	253	16.3
27 X 10	94	140	684	646	12.4	254	18.9
27 X 10	102	152	688	646	13.1	254	21.1
27 X 10	114	170	693	646	14.5	256	23.6
27 X 10	129	192	702	646	15.5	254	27.9
27 X 14	146	217	700	650	15.0	358	25.3
27 X 14	161	240	701	646	16.7	356	27.4
27 X 14	178	265	707	647	19.0	362	30.0
27 X 14	194	289	716	645	19.0	358	33.0
27 X 14	217	323	727	650	21.0	361	38.0
27 X 14	235	350	728	647	23.0	362	41.0
27 X 14	258	384	733	647	25.0	364	44.0
27 X 14	281	418	745	648	28.0	365	49.0
27 X 14	307	457	753	648	30.0	368	53.0
27 X 14	336	500	762	649	32.0	370	57.0
27 X 14	368	548	772	647	33.0	370	61.0
30 X 10 1/2"	90	134	746	716	11.9	265	14.9
30 X 10 1/2"	99	147	753	719	13.2	265	17.0
30 X 10 1/2"	108	161	758	719	13.8	266	19.3
30 X 10 1/2"	116	173	762	719	14.4	267	21.6
30 X 10 1/2"	124	185	766	719	14.9	267	23.6
30 X 10 1/2"	132	196	770	719	15.6	268	25.4
30 X 10 1/2"	148	220	779	719	16.5	266	30.0
30 X 15	173	257	772	722	16.6	390	25.4

VIGA I.P.R.

Dimensión <i>pulgadas</i>	Peso aprox		Peralte ext. (A)	Peralte int. (B)	Alma (C)	Ancho patín (D)	Espesor patín (E)
	<i>lf/ft</i>	<i>kg/m</i>					
30 X 15	191	284	784	722	18.0	384	29.1
30 X 15	211	314	790	722	20.0	385	32.0
30 X 15	235	350	796	722	24.0	385	36.0
30 X 15	261	388	803	723	23.0	389	41.0
30 X 15	292	435	803	720	25.0	385	46.0
30 X 15	326	485	825	722	29.0	390	53.0
30 X 15	357	531	831	723	31.0	388	54.0
30 X 15	391	582	840	718	34.0	388	61.0
33 X 11 1/2"	118	176	835	797	14.0	292	18.8
33 X 11 1/2"	130	193	840	797	14.7	292	21.7
33 X 11 1/2"	141	210	846	797	15.4	293	24.4
33 X 11 1/2"	152	226	851	797	16.1	294	26.8
33 X 11 1/2"	169	252	859	797	17.0	292	31.0
33 X 15 3/4"	201	299	861	801	18.0	403	29.0
33 X 15 3/4"	221	329	862	800	20.0	403	32.0
33 X 15 3/4"	241	359	871	802	21.0	410	34.0
33 X 15 3/4"	263	391	879	800	28.0	402	38.0
33 X 15 3/4"	291	433	885	801	26.0	404	41.0
33 X 15 3/4"	318	473	891	800	27.0	405	51.0
33 X 15 3/4"	354	527	902	801	29.0	403	51.0
33 X 15 3/4"	387	576	911	798	33.0	410	55.0
36 X 12	135	201	903	863	15.2	304	20.1
36 X 12	150	223	911	863	15.9	304	23.9
36 X 12	160	238	915	863	16.5	305	25.9
36 X 12	170	253	919	863	17.3	306	27.9
36 X 12	182	271	923	863	18.4	307	30.0
36 X 12	194	289	927	863	19.4	308	32.0
36 X 12	210	313	932	863	21.1	309	34.5
36 X 12	232	345	940	863	22.0	311	39.0
36 X 12	256	381	948	863	23.0	313	43.0

VIGA I.P.R.

Dimensión <i>pulgadas</i>	Peso aprox		Peralte ext. (A)	Peralte int. (B)	Alma (C)	Ancho patín (D)	Espesor patín (E)
	lf / ft	kg/m					
36 X 16 1/2"	231	344	927	825	19.3	418	32.0
36 X 16 1/2"	247	368	931	824	20.3	419	34.3
36 X 16 1/2"	262	390	936	824	21.3	420	36.6
36 X 16 1/2"	282	420	943	825	22.5	422	39.9
36 X 16 1/2"	302	449	948	825	24.0	423	42.7
36 X 16 1/2"	330	491	957	825	25.9	422	47.0
36 X 16 1/2"	361	537	965	825	28.4	425	51.1
36 X 16 1/2"	395	588	976	825	31.0	427	55.9
36 X 16 1/2"	441	656	987	825	34.5	431	62.0
36 X 16 1/2"	487	725	999	825	38.1	434	68.1
36 X 16 1/2"	529	787	1011	825	40.9	437	73.9
36 X 16 1/2"	652	970	1043	825	50.0	446	89.9
40 X 12	149	222	970	928	16.0	300	21.1
40 X 12	167	249	980	928	16.5	300	26.0
40 X 12	183	272	990	928	16.5	300	31.0
40 X 12	211	314	1000	928	19.1	300	35.9
40 X 12	235	350	1008	928	21.1	302	40.0
40 X 12	249	371	1000	928	19.5	400	36.068
40 X 12	264	393	1016	928	24.4	303	43.9
40 X 12	278	414	1020	928	26.0	304	46.0
40 X 12	294	438	1026	928	27.0	305	49.0
40 X 12	327	487	1036	928	29.9	308	54.1
40 X 12	331	493	1036	928	31.0	309	54.0
40 X 12	392	583	1056	928	36.0	314	64.0
40 X 16	199	296	982	928	16.5	400	27.1
40 X 16	215	320	990	928	16.5	400	31.0
40 X 16	249	371	1000	928	19.0	400	36.1
40 X 16	277	412	1008	928	21.1	402	40.0
40 X 16	297	442	1012	928	23.6	402	41.9
40 X 16	324	482	1020	928	25.4	404	46.0

VIGA I.P.R.

Dimensión <i>pulgadas</i>	Peso aprox		Peralte ext. (A)	Peralte int. (B)	Alma (C)	Ancho patín (D)	Espesor patín (E)
	<i>lf / ft</i>	<i>kg/m</i>					
40 X 16	362	593	1030	928	28.4	407	51.1
40 X 16	372	554	1032	928	29.5	408	52.0
40 X 16	397	591	1040	928	31.0	409	55.9
40 X 16	431	641	1048	928	34.0	412	60.0
40 X 16	503	749	1068	928	39.0	417	70.0
40 X 16	593	882	1092	928	45.5	424	82.0
44 X 16	230	342	1090	1028	18.0	400	31.0
44 X 16	262	390	1100	1028	20.0	400	36.0
44 X 16	290	432	1108	1028	22.0	402	40.0
44 X 16	335	499	1118	1028	26.0	405	45.0



Rejilla de Acero

IS-01

- Distancia entre varillas: 100mm
- Distancia entre soleras: 20.7 mm
- Tamaño de tablero: 0.585 x 6 m
- Peso: consultar las fichas técnicas por configuración de rejilla

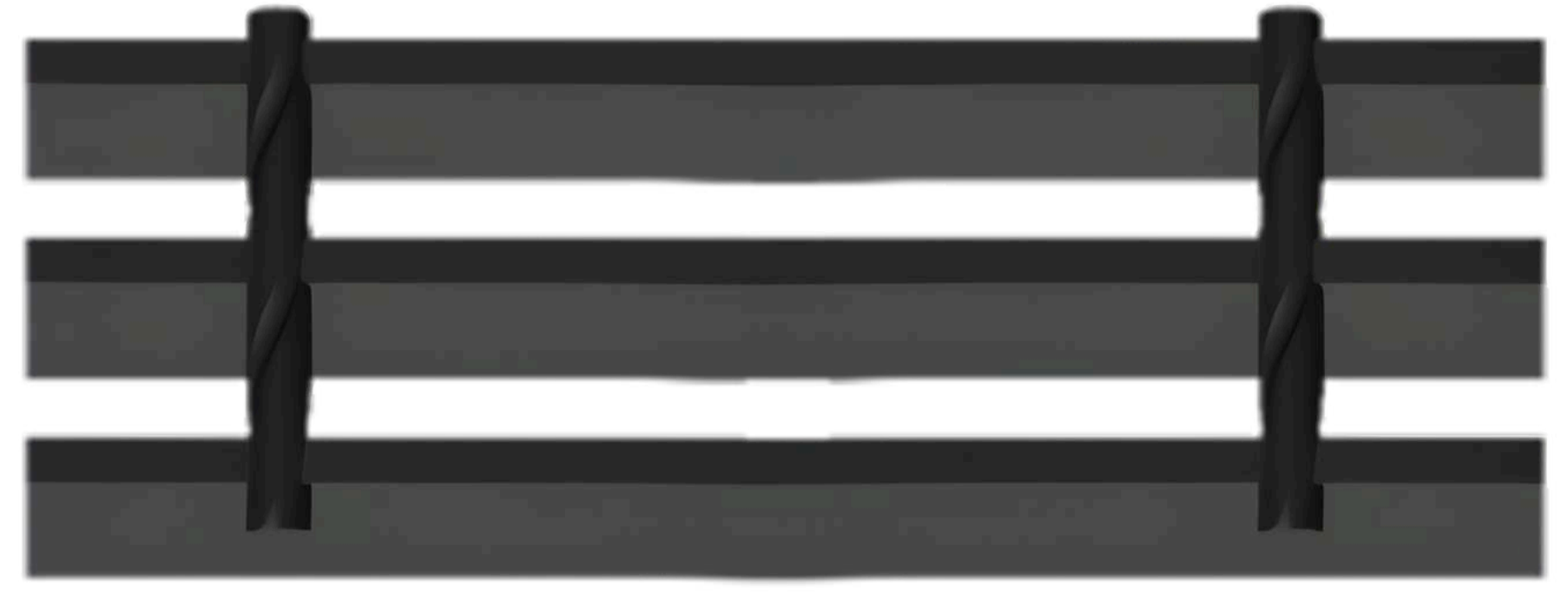

En 1/2 IS-01 la distancia entre soleras es de 41.4 mm

IS-02

- Distancia entre varillas: 50 mm
- Distancia entre soleras: 20.7 mm
- Tamaño de tablero: 0.585 x 6 m
- Peso: consultar las fichas técnicas por configuración de rejilla

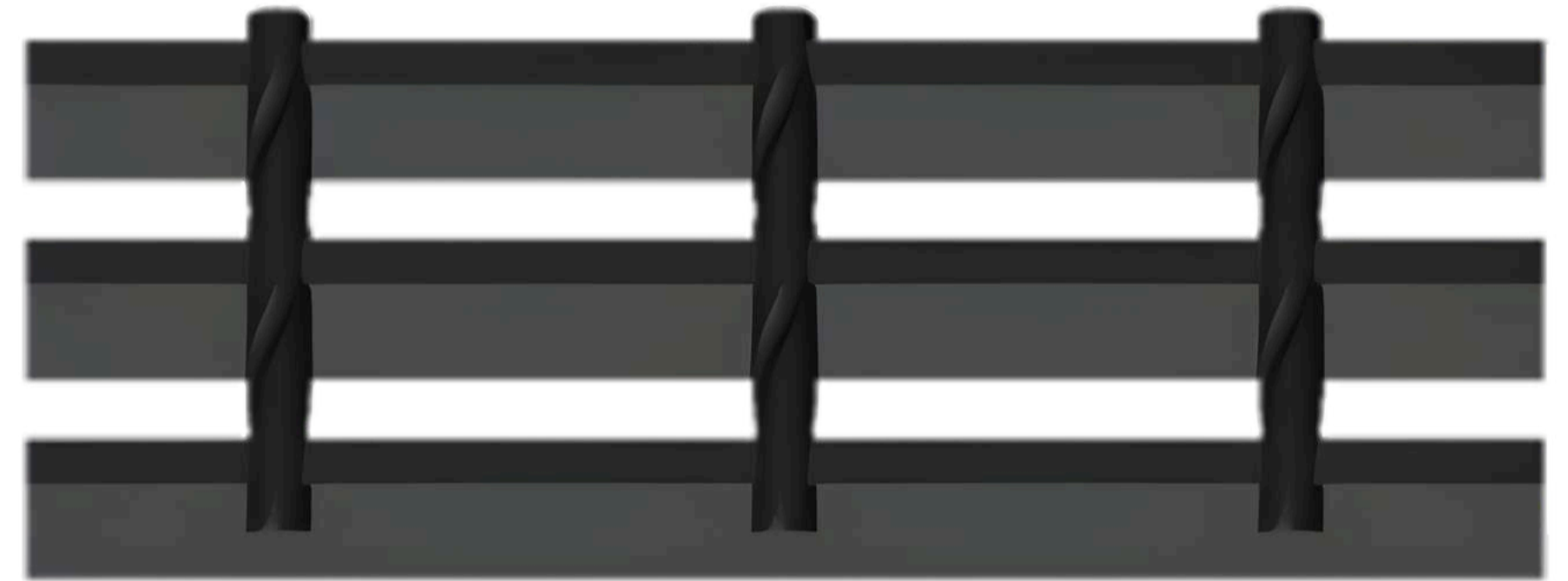

En 1/2 IS-02 la distancia entre soleras es de 41.4 mm

IS-03

- Distancia entre varillas: 100 mm
- Distancia entre soleras: 24.3 mm
- Tamaño de tablero: 0.806 x 6 m
- Peso: consultar las fichas técnicas por configuración de rejilla



En 1/2 IS-03 la distancia entre soleras es de 48.6 mm

Rejilla de Acero

IS-04

- Distancia entre varillas: 50mm
- Distancia entre soleras: 24.3 mm
- Tamaño de tablero: 0.806 x 6 m
- Peso: consultar las fichas técnicas por configuración de rejilla

En 1/2 IS-04 la distancia entre soleras es de 48.6 mm

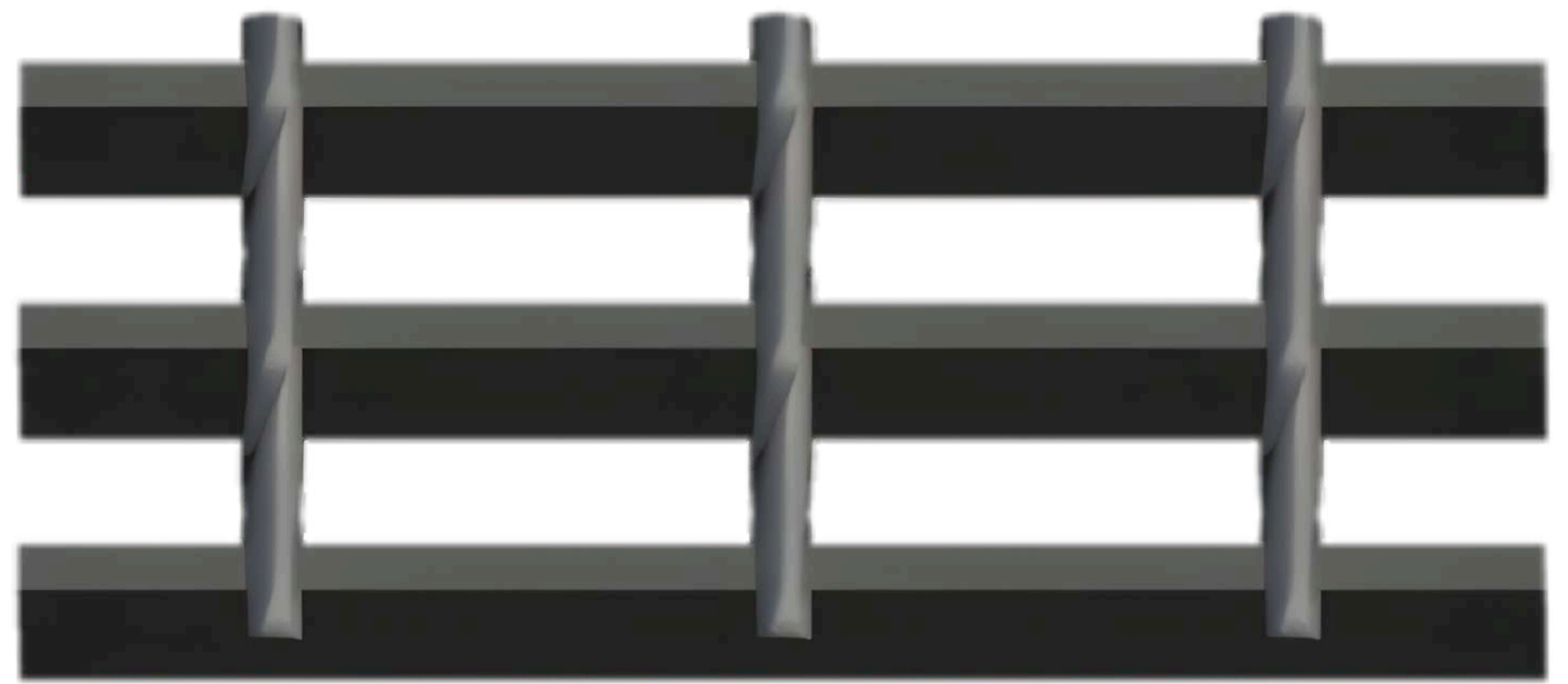

IS-05

- Distancia entre varillas: 100 mm
- Distancia entre soleras: 30.2 mm
- Tamaño de tablero: 1 x 6 m
- Peso: consultar las fichas técnicas por configuración de rejilla

En 1/2 IS-05 la distancia entre soleras es de 60.4 mm

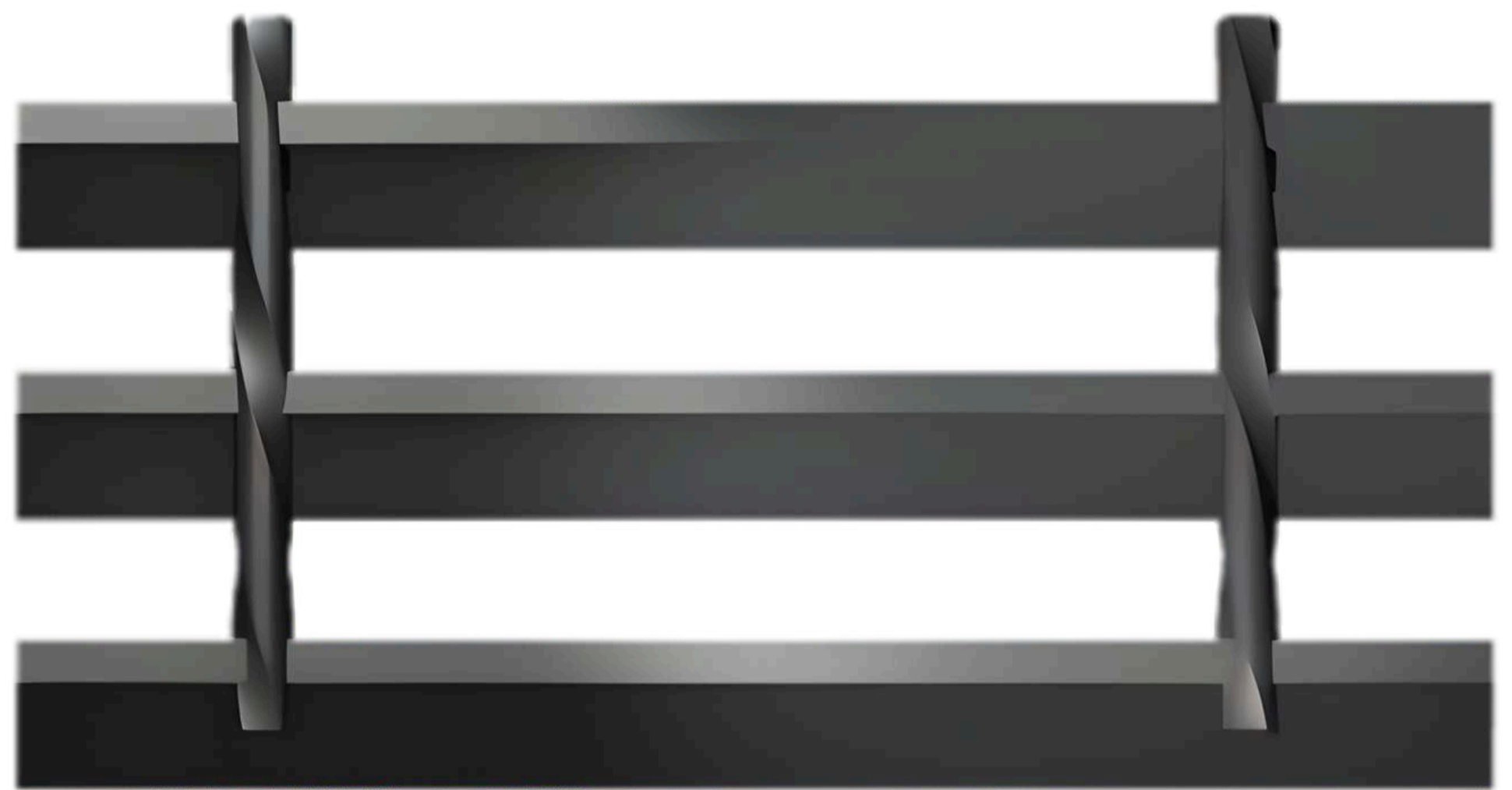

IS-06

- Distancia entre varillas: 50 mm
- Distancia entre soleras: 30.2 mm
- Tamaño de tablero: 1 x 6 m
- Peso: consultar las fichas técnicas por configuración de rejilla

En 1/2 IS-06 la distancia entre soleras es de 60.4 mm

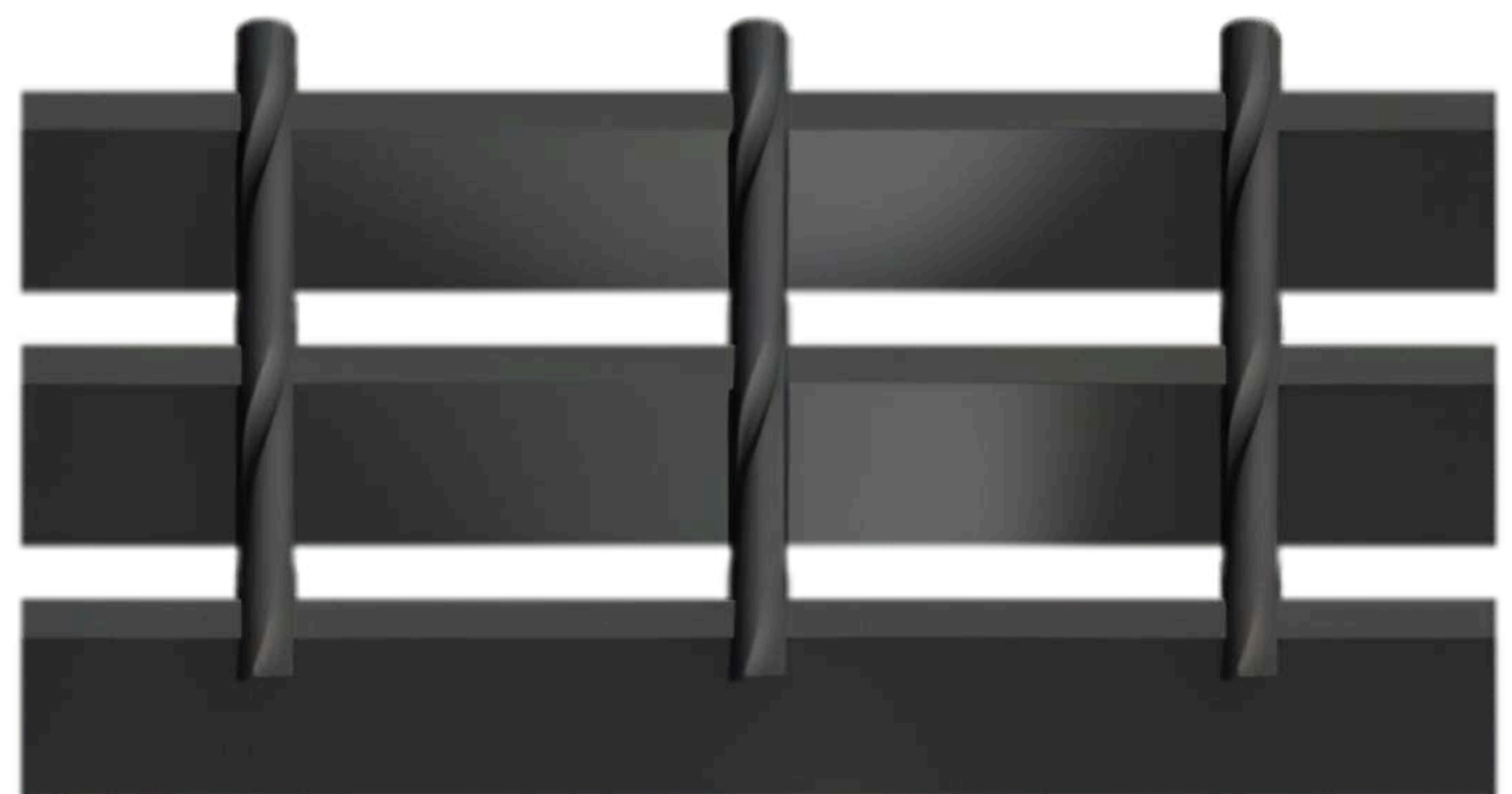

Rejilla de Acero

Peso nominal de la rejilla Electroforjada de acero tipo IS-05

Soleras de carga

Milímetros	Pulg.	Kg/m ²
3.2 X 19.1	1/8" x 3/4"	19.1
3.2 x 25.4	1/8" x 1"	24.4
3.2 x 31.8	1/8" x 1-1/4"	29.8
3.2 x 38.1	1/8 x 1 - 1 / 2"	35.2
4.8 x 19.1	3/ 16" x 3 / 4 "	27.1
4.8 x 25.4	3/16 x 1	35.2
4.8 x 31.8	3/16" x 1 - 1 / 4"	43.3
4.8 x 38.1	3/ 16 x 1- 1 / 2"	51.3
4.8 x 44.4	3/ 16" x 1 - 3 / 4"	59.7
4.8 x 50.8	3/16 " x2"	67.7

PESO NOMINAL DE LA REJILLA ELECTROFORJADA DE ACERO

SOLERAS DE CARGA

milímetros	pulg.	IS-01" (kg/m ³)	IS-02° (kg/m ²)	15-03 (kg/m ²)	IS-04 (kg/m ²)	IS-06° (kg/m ²)
3.2 x 19.1	1/8"x3/4"	26.2	29.1	22.9	25.8	22
3.2 x 25.4	1/8"x1"	33.9	36.9	29.5	32.4	27.4
3.2 x 31.8	1/8" x1-1/4"	41.7	44.6	36.1	39.1	32.8
3.2 x 38.1	1/8"x1-1/2"	49.4	52.4	42.8	45.7	38.1
4.8 x 19.1	3/16" x 3/4"	37.8	40.7	32.8	35.8	30.1
4.8 x 25.4	3/16"x1"	49.4	52.4	42.8	45.7	38.1
4.8 x 31.8	3/16"x1-1/4"	61.1	64	52.7	55.7	46.2
4.8 x 38.1	3/16"x1-1/2"	72.7	75.6	62.7	65.7	54.3
4.8x44.4	3/16"x1-3/4"	84.6	87.8	72.9	76.2	62.9
4.8 x 50.8	3/16"x2"	96.2	99.4	82.9	86.1	70.9
4.8 x 57.1	3/16"x2-1/4"	107.8	111	92.9	96.1	79
4.8 x 63.5	3/16"x2-1/2"	119.4	122.6	102.8	106	87.1



SERVICIOS ESPECIALIZADOS

En Perfiles y Estructuras Maresta nos enfocamos en brindar a nuestros clientes un servicio integral para facilitar sus proyectos:

- ✓ **Corte y barrenado**
- ✓ **Pintura**
- ✓ **Anclas**



CORTE Y BARRENADO

CORTE

En Perfiles y Estructuras Maresta nuestros objetivos de satisfacción al cliente son eficientes y ofrecemos cortes con acabados de precisión absoluta, otorgando la confianza de obtener productos a la medida. El servicio de corte se puede realizar en largos desde 20 hasta 40 pies.



Características y técnicas de corte:

Máximo ángulo de rotación	+ 45° (cuadrante IV)
Mínimo ángulo de rotación	- 60 (cuadrante III)
Corte recto 90°	1,200 x 45 mm (ancho x alto)
Corte en ángulo 45°	870 x 450 mm (ancho x alto)
Corte en ángulo -45°	820 x 450 mm (ancho x alto)
Corte en ángulo -60°	600 x 450 mm (ancho x alto)
Máximo largo de perfiles	12,200 mm (40 ft)

BARRENADO

Nuestro servicio de barrenado cuenta con la tecnología para ejecutar de forma eficiente este tipo de procesos de forma rápida y continua.

Características y técnicas:

Altura máxima de trabajo	45 mm
Altura mínima de trabajo	5 mm
Anchura máxima de trabajo	1,200 mm
Anchura mínimade trabajo	50 mm
Diámetro máximode barreno	40 mm
Diámetro mínimode barreno	8 mm
Orientación	0°, 90°, 180° y 270°

PINTURA

Nuestro sistema de pintura ofrece el servicio de primera capa de primario, anticorrosivo, époxico. Con un espesor de 2 a 3 micras de pintura. Ofreciendo la aplicación de cualquier primario **bajo las normas de CFE ó PEMEX.**



VENTAJAS DE APLICACIÓN DE PINTURA:

- **Mejora la adherencia** de cualquier tipo de **revestimiento o pintura**, por la calidad de la limpieza.
- Excelente aspecto visual de la pieza.
- Un excelente acabado de pintura primaria.

ANCLAS

Fabricación de **anclas roscadas** con redondo o varilla para cimentación.

- Anclas desde 3/8" hasta 2 1/2"

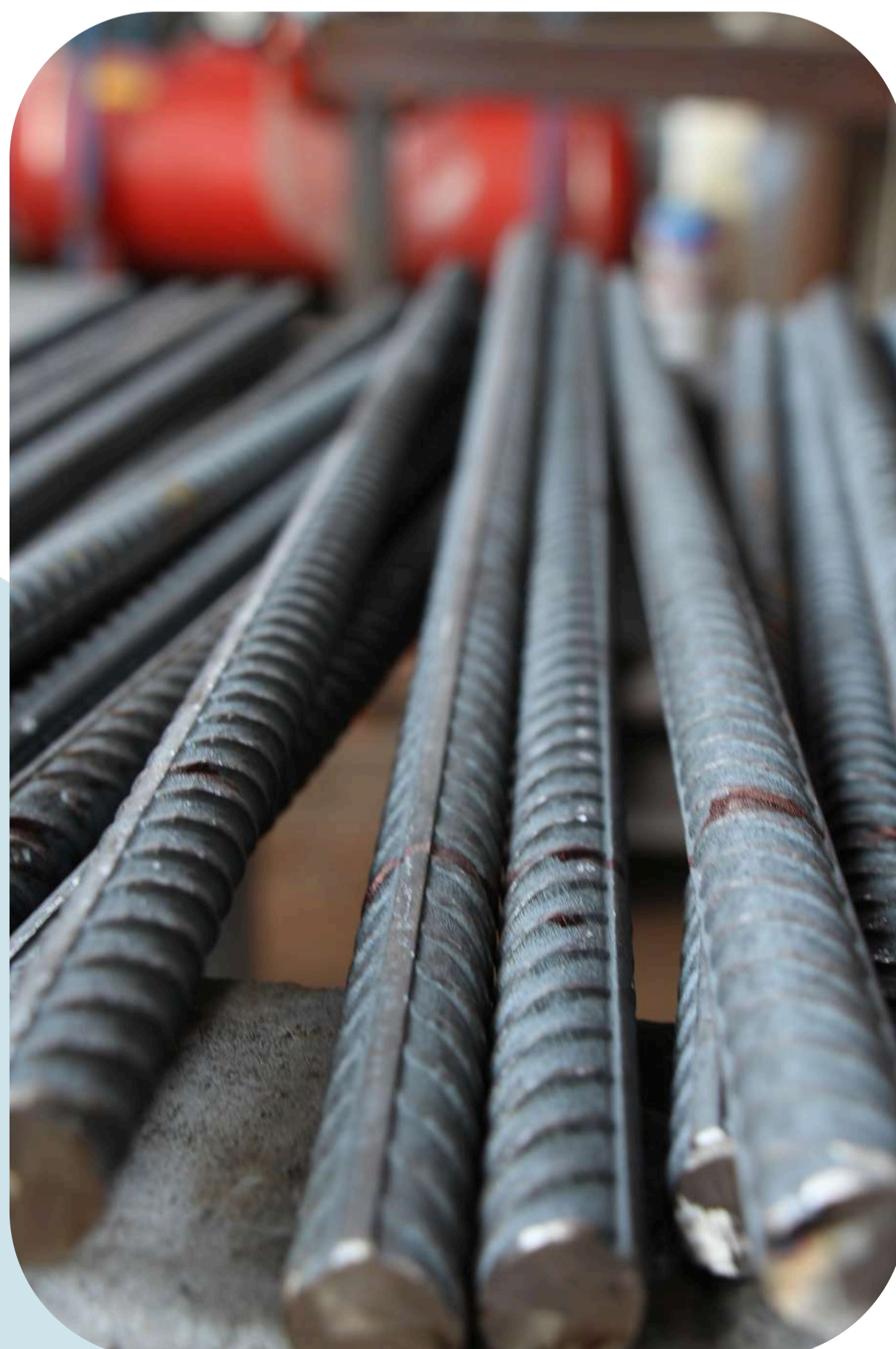
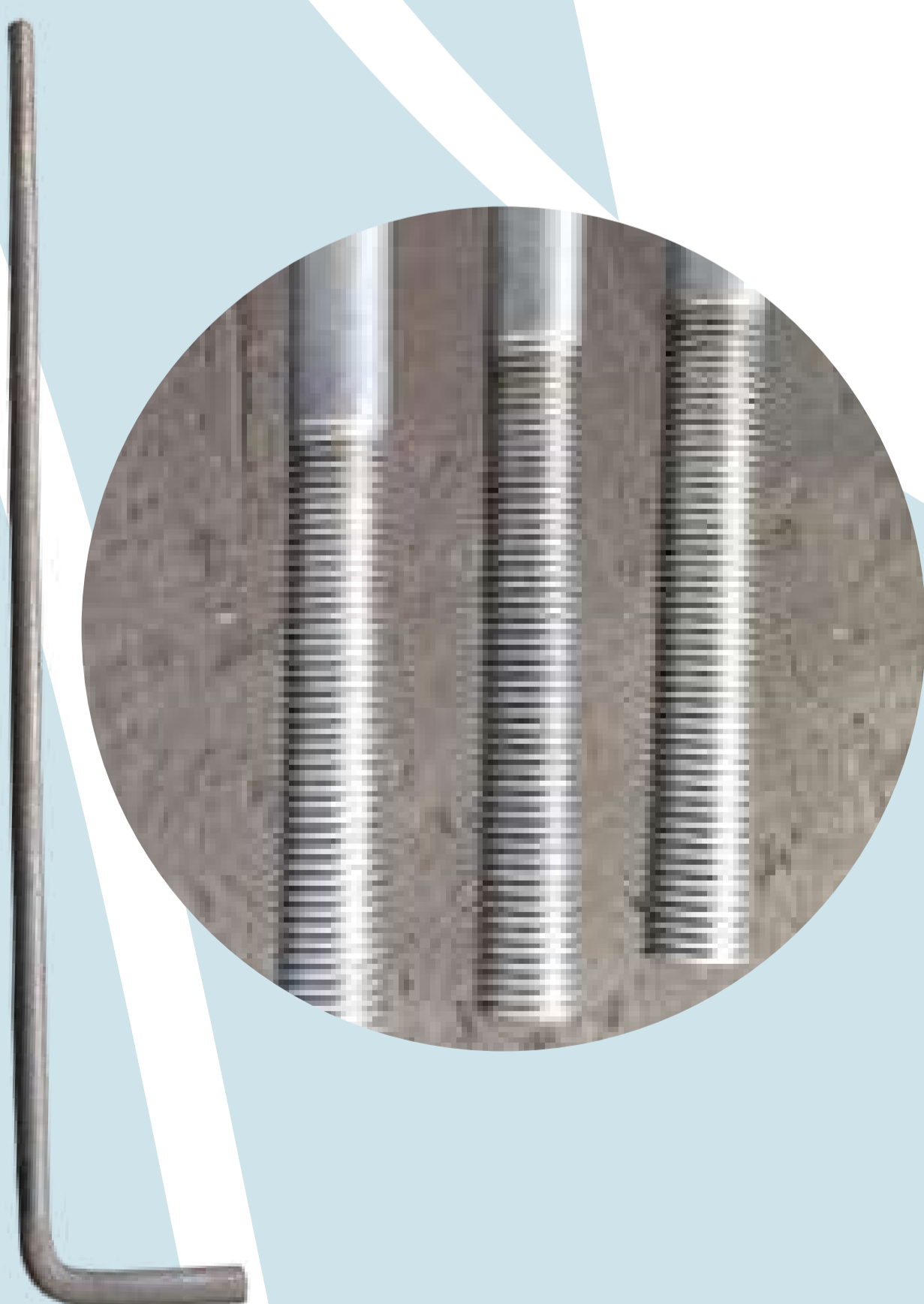



SERVICIO INTEGRAL PARA TUS PROYECTOS

ATENCIÓN PERSONALIZADA

- ✓ Servicio de calidad
- ✓ Entregas a tiempo
- ✓ Precios competitivos



¡VAMOS A TODA LA REPÚBLICA MEXICANA!





Servicio de fabricación y montaje de estructuras metálicas en acero estructural de la más alta calidad, para tus proyectos más exigentes.



TOLERANCIA EN ESPESOR ASTM

Calibre	Espesor		R.C.D.		48"	R.F."
	mm	pulg.	R.C.S.D. 36"			
3	6.07	0.2391	0.2471			
			0.2311			
4	5.69	0.2242	0.2322		0.2322	
			0.2162		0.2162	
			0.2172		0.2182	
5	5.31	0.2092	0.2012		0.2002	
			0.2023		0.2023	
6	4.95	1.1943	0.1863		0.1853	
			0.1955		0.1965	
3/16	4.76	0.1875	0.1795		0.1785	
			0.1863		0.1873	
7	4.55	0.1793	0.1723		0.1773	
			0.1714		0.1724	
8	4.18	0.1644	0.1574		0.1564	
			0.1565		0.1575	
9	3.80	0.1495	0.1425		0.1415	
			0.1415		0.1425	0.1405
10	3.42	0.1345	0.1275		0.1265	0.1285
			0.1320		0.1330	0.131
1/8	3.17	0.1250	0.1180		0.1170	0.119
			0.1266		0.1276	0.1256
11	3.04	0.1196	0.1126		0.1116	0.1136
			0.1116		0.1126	0.1106
12	2.66	0.1046	0.0976		0.0966	0.0986
			0.0967			0.0947
13	2.28	0.0897	0.0827			0.0847
			0.0817			0.0797
14	1.9	0.0747	0.0677			0.0697
			0.0733			0.0723
15	1.71	0.0673	0.0613			0.0623
			0.0745			0.0675
1/16	1.58	0.0625	0.0505			0.0575
			0.0658			0.0648
16	1.52	0.0598	0.0538			0.0548
			0.0588			0.0578
17	1.93	0.0538	0.0488			0.0498
			0.0528			0.0518
18	1.21	0.0478	0.0428			0.0438
						0.0458

TOLERANCIA EN ESPESOR ASTM

Calibre	Espesor		R.C.D.		
	mm	pulg.	R.C.S.D. 36"	48"	R.F."
1/32	0.79	0.0312			0.3242
					0.0282
22	0.76	0.0299			0.0329
					0.0269
23	0.68	0.0269			0.0299
					0.0239
24	0.61	0.0239			0.0269
					0.0209
25	0.53	0.0209			0.0239
					0.0179
26	0.45	0.0179			0.0199
					0.0159
27	0.42	0.0164			0.0184
					0.0144
28	0.38	0.0149			0.0169
					0.0129
29	0.34	0.0135			
30	0.3	0.0120			
1/4	6.35	0.2500			0.2800
					0.2620
5/16	7.93	0.3125			0.2400
					0.2380
3/8	9.52	0.3750			0.3420
					0.3245
7/16	11.11	0.4375			0.3020
					0.3005
1/2	12.7	0.5000			0.4050
					0.3880
9/16	14.28	0.5625			0.3650
					0.3620
5/8	15.87	0.6250			0.4670
					0.4515
11/16	17.46	0.6875			0.4270
					0.4235
3/4	19.05	0.7500			0.5300
					0.5140
13/16	20.63	0.8125			0.4900
					0.4860
7/8	22.22	0.8750			0.5920
					0.5775
15/16	23.81	.9375			0.5220
					0.5475
1	25.40	1.000			0.6550
					0.6400
					0.6150
					0.6100
					0.7170
					0.7035
					0.6770
					0.6715
					0.7800
					0.7660
					0.7400
					0.7340
					0.8420
					0.8285
					0.8020
					0.7965
					0.9050
					0.8910
					0.8650
					0.8590
					0.9670
					0.9535
					0.9270
					0.9215
					1.0600
					1.0160
					0.9900
					0.9840



Estamos comprometidos en trabajar con los más altos estándares de calidad para garantizar que sus proyectos sean satisfactorios y nos sigan recomendando.

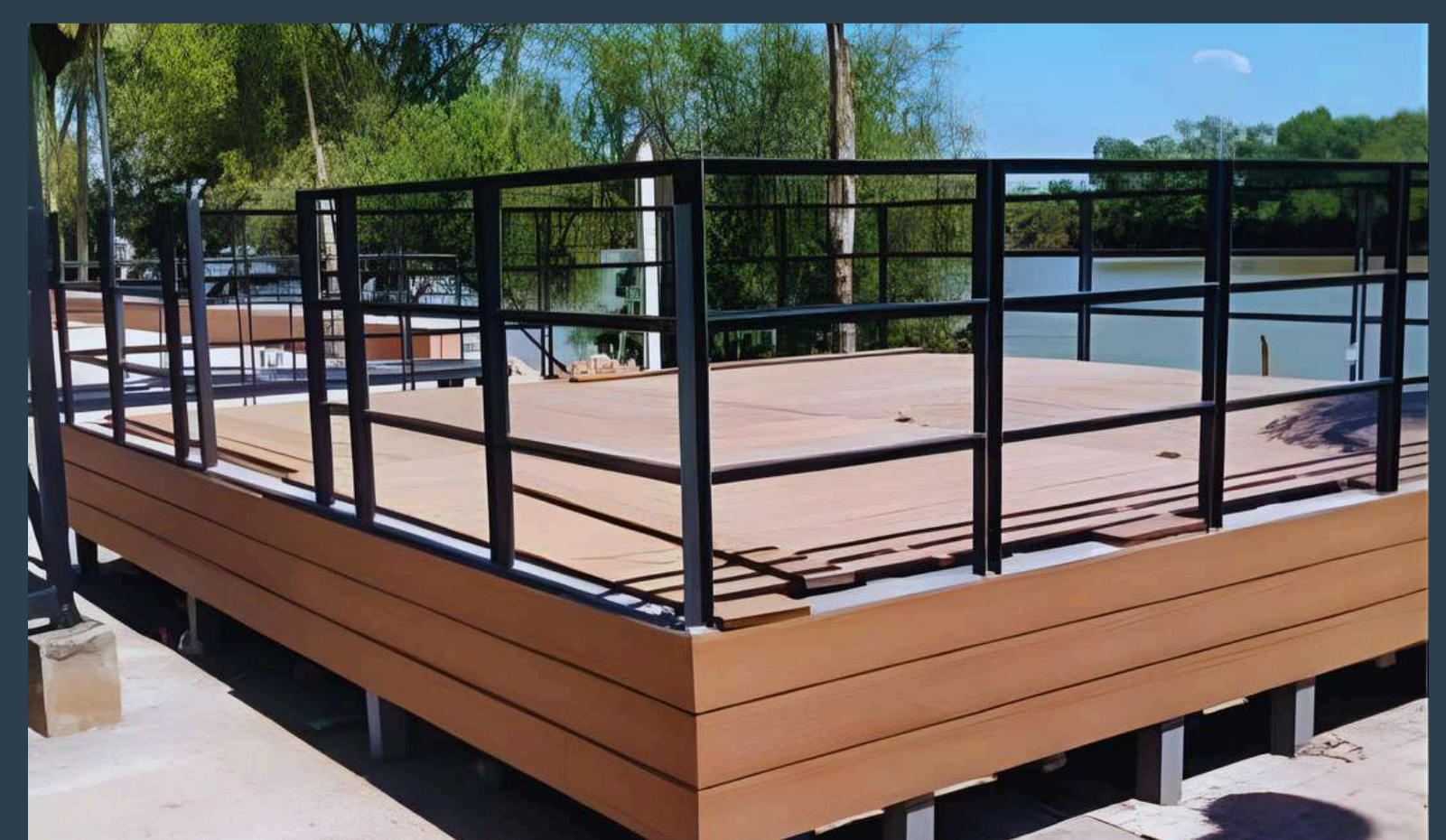

FACTORES DE CONVERSIÓN

Kilogramos por metro multiplicar por 0.671957 = Libras por pie

Libras por pie: multiplicar por 1.48818 = kilogramo por metro

1 kilogramo = 2.2046 libras

1 Libra = 0.453592 kilogramos

1 Pulgada = 25.4 milímetros

1 pie = 12 pulgadas = 304.8 milímetros

Placa 5 x 20: $72.77 \times \text{espesor (mm)} = \text{kg / placa}$

Placa 6 x 20: $87.66 \times \text{espesor (mm)} = \text{kg / placa}$

Placa 8 x 20: $116.82 \times \text{espesor (mm)} = \text{kg / placa}$



Importante a considerar: Todos los pesos que se anuncian en el presente catálogo son “pesos teóricos” basados en las especificaciones de los fabricantes y pueden llegar a tener un peso de variación en cada uno de los productos.

Catálogo de productos edición 2026 | versión 1.3

© Todos los derechos reservados. CONSTRUCCIÓN Y EDIFICACIÓN METÁLICAS MARESTA 2026 elaborado con referencias y especificaciones de los fabricantes.



En CONSTRUCCIÓN Y EDIFICACIÓN METÁLICAS MARESTA agradecemos a cada uno de nuestros clientes, por la confianza y permitirnos hacer sinergia en sus proyectos.



CONSTRUCCIÓN Y EDIFICACIÓN METÁLICAS MARESTA

SUMINISTRO

**DE ACERO ESTRUCTURAL
Y ACERO DE REFUERZO**

DISEÑO

**DE ESTRUCTURAS Y
PROYECTOS METÁLICOS**

MONTAJE

**VAMOS A TODA LA
REPÚBLICA MEXICANA**

TELÉFONOS OFICINA:



55 9703 9904 / 55 9703 9905
55 9702 4530 / 55 9702 4531



cemmsa@construccionmaresta.com



AV. INSURGENTES, MZNA.22 LT.17
COL. REFORMA POLÍTICA, ALCALDIA
IZTAPALAPA, CDMX. C.P.09710