



tecplot[®] 360 **ex**

Getting Started Manual
Tecplot 360 2025 Release 2

Tecplot, Inc.



Copyright © 1988-2026 Tecplot, Inc. All rights reserved worldwide. See the complete [legal notice](#) in the copyright section of this document.

Table of Contents

- Introduction 6
 - Before You Start the Tutorials 6
 - Tutorials In This Guide 7
- Part 1: General Application 8
 - External Flow 9
 - Loading and Manipulating Data 9
 - Step 1: Launch Tecplot 360 and Load the Data Set 9
 - Step 2: Rotate the Wing 12
 - Step 3: View Information About the Data Set 12
 - Step 4: Disable Bounding Box for Fluid Volume Zone 14
 - Step 5: View the Mesh Using the Context Toolbar 16
 - Step 6: Change the Mesh Color 16
 - Step 7: Set Up Contour Groups and Color Maps 19
 - Step 8: Change Contour Group on Plot 23
 - Step 9: Format Legend 24
 - Exploring a CFD Solution 27
 - Step 1: Add a Slice 27
 - Step 2: Set Slice Details 30
 - Step 3: Show Contours 32
 - Step 4: Prepare for Streamtraces 36
 - Step 5: Seed Streamtraces 39
 - Step 6: Seed Volume Ribbons 42
 - Step 7: Adjust Rotation and Lighting 46
 - Step 8: Surface Streamtraces 46
 - Step 9: Create Iso-Surfaces 49
 - Step 10: Probe Data 56
 - Comparing a CFD Simulation with Experimental Data 57
 - Step 1: Load Layout 57
 - Step 2: Append Experimental Data 57
 - Step 3: Variable Load and Combine 59
 - Step 4: Normalize Y to Y/b 60
 - Step 5: Extract Slice from Simulation Data at Pressure Tap Location 63
 - Step 6: Normalize Slice's X to X/L 67
 - Step 7: Create XY Plot of Slice 69
 - Step 8: Plot Experimental Data 73
 - Step 9: Add Error Bars 77

Step 10: Final Polishing	78
Next Steps	80
Understanding Volume Surfaces	81
Understanding Volume Surfaces	81
Step 1: Launch Tecplot 360 and Load the Data Set	81
Step 2: Surfaces to Plot and the Zone Style dialog	83
Step 3: Contours and Surface Data	84
Step 4: Changed Surfaces to Plot in the Zone Style Dialog	85
Next Steps	86
Transient Data	87
Loading and Exploring Transient Data	87
Step 1: Launch Tecplot 360 and Load the Data Set	87
Step 2: Get A Good Look	89
Step 3: Dive into Data Set Info	90
Step 4: Time Strands in the Zone Style Dialog	92
Step 5: Visualizing a Contour Plot	93
Step 6: Visualize the Flow With Streamtraces	94
Step 7: Animate Your Plot	96
Extracting Data	97
Step 1: Create a Vertical Line	98
Step 2: Extract the Line Over Time	99
Step 3: Create A Line Plot of Pressure	102
Step 4: Link the Time Steps and Animate the Plot	107
Step 5: Time Series Plot	109
Frequency Analysis Using Fourier Transform	111
Step 1: Fourier Transform	112
Step 2: Re-Analyzing at a New Position	115
Calculations and Contour Cutoff	117
Step 1: Set Field Variables	118
Step 2: Calculate Vorticity Magnitude	118
Step 3: Show Vorticity Magnitude on Contour Plot	120
Step 4: Adjust Cutoff	123
Step 5: Polishing the Plot	124
Step 6: Animate It	126
Next Steps	127
Finite Element Analysis	128
Calculating Von Mises Stress Along a Surface	128
Step 1: Load the Data Set	128

Step 2: Slow Animation Down	130
Step 3: Calculate Von Mises Stress	131
Step 4: Contour by Von Mises Stress	133
Step 5: Isolate the Connecting Rod	135
Step 6: Identify the Critical Failure Threshold	136
Step 7: 3D Multi Frames	138
Data Alter with If Statements	139
Step 1: Specify an Equation	139
Step 2: Contour It	140
Step 3: Flood by Primary Cell Value	142
Plot Maximum Stress Over Time	143
Step 1: Load the Macro	143
Step 2: Macro Breakdown: Create a Zone	144
Step 3: Macro Breakdown: Alter Variables	145
Step 4: Macro Breakdown: Create XY Plot	146
Next Steps	147
Part 2: Internal Combustion Engines	149
Internal Combustion Engines	150
Loading and Manipulating Data	150
Step 1: Launch Tecplot 360 and Load the Data Set	150
Step 2: Disable Bounding Box for Fluid Volume Zone	153
Step 3: Hide Exhaust Ports	153
Exploring the Data Set	155
Step 1: Adding a Slice	155
Step 2: Set Slice Styles	157
Step 3: Showing Spray Parcels	159
Step 4: Changing Spray Parcel Size	160
Step 5: Changing Spray Parcel Color	161
Step 6: Creating an Iso-surface	165
Step 7: Using 3D Multi Frames	168
Step 8: Export to Movie File	169
Loading Cell Averaged Output Files (CONVERGE)	171
Step 1: Loading the data	171
Step 2: Add Multiple Y Axes	172
Step 3: Add Grid Lines	174
Step 4: Update Axis Labels	176
Next Steps	178
Part 3: Ocean Modeling	179

Ocean Modeling	180
Loading and Manipulating Data	180
Step 1: Launch Tecplot 360 and Load the Data Set	180
Step 2: Inspecting the Data	183
Making your first plot	184
Step 1: Turn on Contour to See the Domain	184
Step 2: Assign XYZ to Lon, Lat	185
Step 3: Adjusting Z-scaling	186
Step 4: Change View and Lighting	187
Step 5: Change the Contour Variable and Colormap	188
Step 6: Use Value Blanking to Hide Dry Land	190
Step 7: Animating and Exporting a Movie File	192
Specific Ocean Plots	194
Visualizing Surface Velocities	194
Step 1: Turn on the Vectors	194
Step 2: Value Blank Siglev	195
Step 3: Use Vector Tangents	196
Step 4: Calculate Velocity Magnitude	197
Step 5: Contour by Velocity Magnitude	200
Step 6: Resize Vectors	201
Insert a Georeferenced Image	203
Step 1: Set Up Coordinate System	203
Step 2: Insert Georeferenced Image	204
Step 3: Update Image location	204
Understanding Salinity Stratification	206
Step 1: Turn off Zone Layers	206
Step 2: Show the Bathymetry	206
Step 3: Place a Slice	209
Step 4: Contour the Slice by Salinity	211
Advanced Topics	213
Vertical Transect (external video)	213
Time Average (external video)	213
Shapefile conversion (external video)	214
Next Steps	214
Copyright	215

Introduction

Tecplot 360 allows you to interactively explore, visualize, and analyze your CFD data, and then communicate your results. With Tecplot 360, you can produce high-quality plots for reports, papers, presentations, videos, or web sites.

The user documentation for Tecplot 360 includes these resources:

Getting Started Manual (this document)

Highlights how to work with key features through a tutorial revolving around data files similar to those you might use.

User's Manual

Complete documentation of all Tecplot 360 features.

Scripting Guide

Information on working with Tecplot 360 macros and a full syntax reference.

Quick Reference Guide

A handy reference for all the little details of using Tecplot 360, such as text placeholders, keyboard shortcuts, and much more.

Data Format Guide

Tecplot data formats and how to write them.

Installation Guide

How to install Tecplot 360 on your machine.

Release Notes

Information on the latest Tecplot 360 features along with platform-specific notes.

This manual includes four tutorials to help you get started with Tecplot 360. For in-depth information on any of the topics covered in the **Getting Started Manual**, please refer to the [User's Manual](#) which is included in your Tecplot 360 installation directory or on our website at: www.tecplot.com/documentation.

Before You Start the Tutorials

Before beginning a tutorial from this guide, we suggest you read through Chapters 1 and 2 of the [User's Manual](#) to introduce yourself to the Tecplot 360 user interface and familiarize yourself with the product's basic concepts of operation. It may be helpful to have Tecplot 360 open while reading these chapters so you can experiment a little.

Chapter 1 - Introduction

Covers the Welcome Screen, supported input devices, the Tecplot 360 workspace, the menu bar and global toolbar, context menus and toolbars, and sidebars. Reading this chapter will orient you to the main user interface controls of Tecplot 360, making it easier to find what you're looking for when you are working on the tutorial.

Chapter 2 - Using the Workspace

Covers data hierarchy, coordinate systems, frames, workspace management, view modification, and the edit menu. You will get practice with many of these concepts in the pages that follow. You may want to review Chapter 2 again after completing the tutorial.

Tutorials In This Guide

This **Getting Started Manual** is divided into tutorials, each of which contains a series of exercises covering various aspects of the topic at hand. The tutorials are designed so you can do them in any order you like, but within a tutorial, it is best to go through the exercises in order if possible (though we do try to provide guidance on how to pick up in midstream).

All of the tutorials in this guide have datasets located in the [Getting Started Bundle](#). A few datasets are located in the example folder in the installation directory, [OneraM6Wing](#) and [DuctFlow.plt](#) as well as the Getting Started Bundle.

The tutorials are:

External Flow

Using the Onera M6 wing model, covers loading the data, producing a basic plot, slicing, streamtraces, isosurfaces, probing, and comparing simulated and experimental data (including normalizing the data).

Understanding Volume Surfaces

Uses the DuctFlow data set as an example of how Tecplot 360 renders volume surfaces using Surfaces to Plot.

Transient Data

Uses a wind turbine data set with 127 time steps to understand how transient (time-based) data is structured and how to produce animated contour plots, extract data over time for analysis, and calculate and visualize additional variables using the Tecplot 360 analysis tools.

Finite Element Analysis

Uses a transient FEA dataset of a connecting rod created with LS-DYNA to explore multiple ways to visualize the maximum Von Mises Stress of the rotating rod.

Dive in and master the view!

Part 1: General Application

External Flow

The Onera M6 wing is a standard design for basic studies of 3D flows at high Reynolds numbers from low to transonic speeds (that is, local supersonic flow, shocks, and turbulent boundary layer separation). The wing was tested by NASA in a wind tunnel at four different Mach numbers and various angles of attack. This is now a classic CFD validation case for external flows because it has a simple geometry, complex flows, and because it includes experimental data against which a CFD solution can be validated. For more about the Onera M6 wing, see turbmodels.larc.nasa.gov/onerawingnumerics_val.html.

This tutorial uses the Onera M6 data set as your entry into Tecplot 360, introducing basic operations at first (loading data and manipulating the view) and progressing to more intermediate and then advanced operations. We chose this data set because you may already be familiar with it (and if you're not, it's straightforward to understand).

The Onera M6 data set is in the [OneraM6wing](#) folder inside the [Getting Started Bundle](#).

This tutorial is divided into three segments. We have provided a layout file for the end of each segment, so you can check your work. There is also a macro included to generate an enhanced version of one of the plots in the third segment, and a layout showing its results. The segments are:

Number and Level	Title and Description
1 - <i>Beginner</i>	Loading and Manipulating Data - Load the Onera M6 simulation data set into Tecplot 360 and create a contour plot, along the way discovering how to rotate a 3D plot, view and color a mesh, set up contour groups and color maps, and display a legend.
2 - <i>Intermediate</i>	Exploring a CFD Solution - Further explore and understand the Onera M6 simulation data set by adding slices, streamtraces, and iso-surfaces, and by probing data.
3 - <i>Intermediate</i>	Comparing a CFD Simulation with Experimental Data - Create a coefficient of pressure (Cp) plot comparing simulated data with experimental data, including normalizing the dimensions of the simulation data set.

A video version of this tutorial is available on the Web at www.tecplot.com/category/tecplot-360-videos/external-flow. The videos may have minor differences from the printed version of the tutorial in this manual, but they end up in the same places.

Loading and Manipulating Data

Step 1: Launch Tecplot 360 and Load the Data Set

Start Tecplot 360 from the Start menu (Windows), by typing `tec360` in a terminal window (Linux), or by double-clicking the application icon in the Applications folder (Mac). The Tecplot 360 Welcome Screen appears, as shown here. (We will show the Windows version of Tecplot 360 in this document, but the product looks substantially the same on other platforms.)

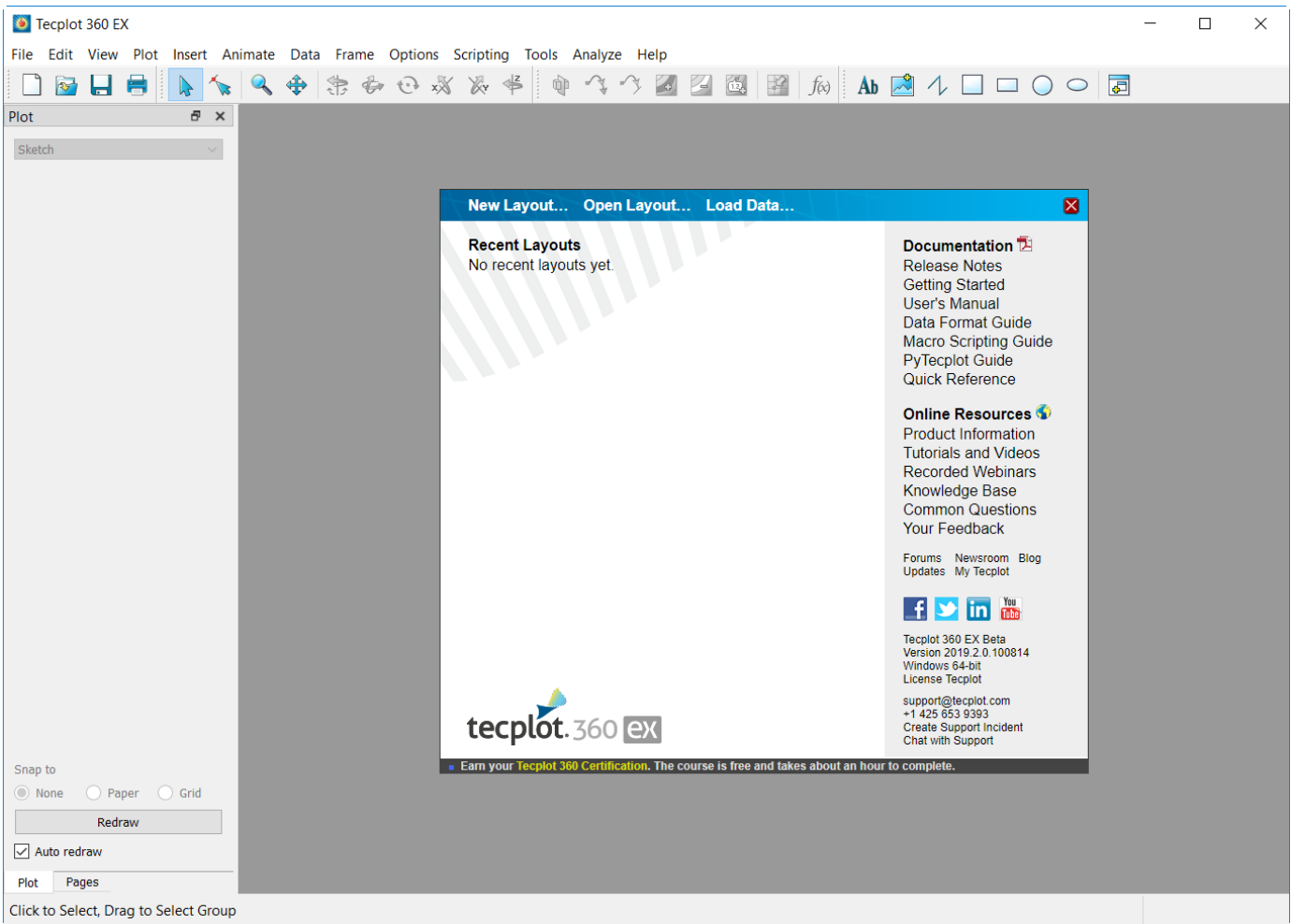

The Welcome Screen appears each time you launch Tecplot 360 and gives you easy access to layouts you have recently worked with, along with quick links to documentation and other resources to help you get the most out of the product.

To begin loading the Onera M6 data, click **Load Data** at the top of the Welcome Screen. (You may also choose **Load Data** from the **File** drop-down menu in the menu bar, or click the folder icon, second from the left, in the toolbar. These alternate methods are convenient when the Welcome Screen isn't visible.)

The Load Data dialog appears.

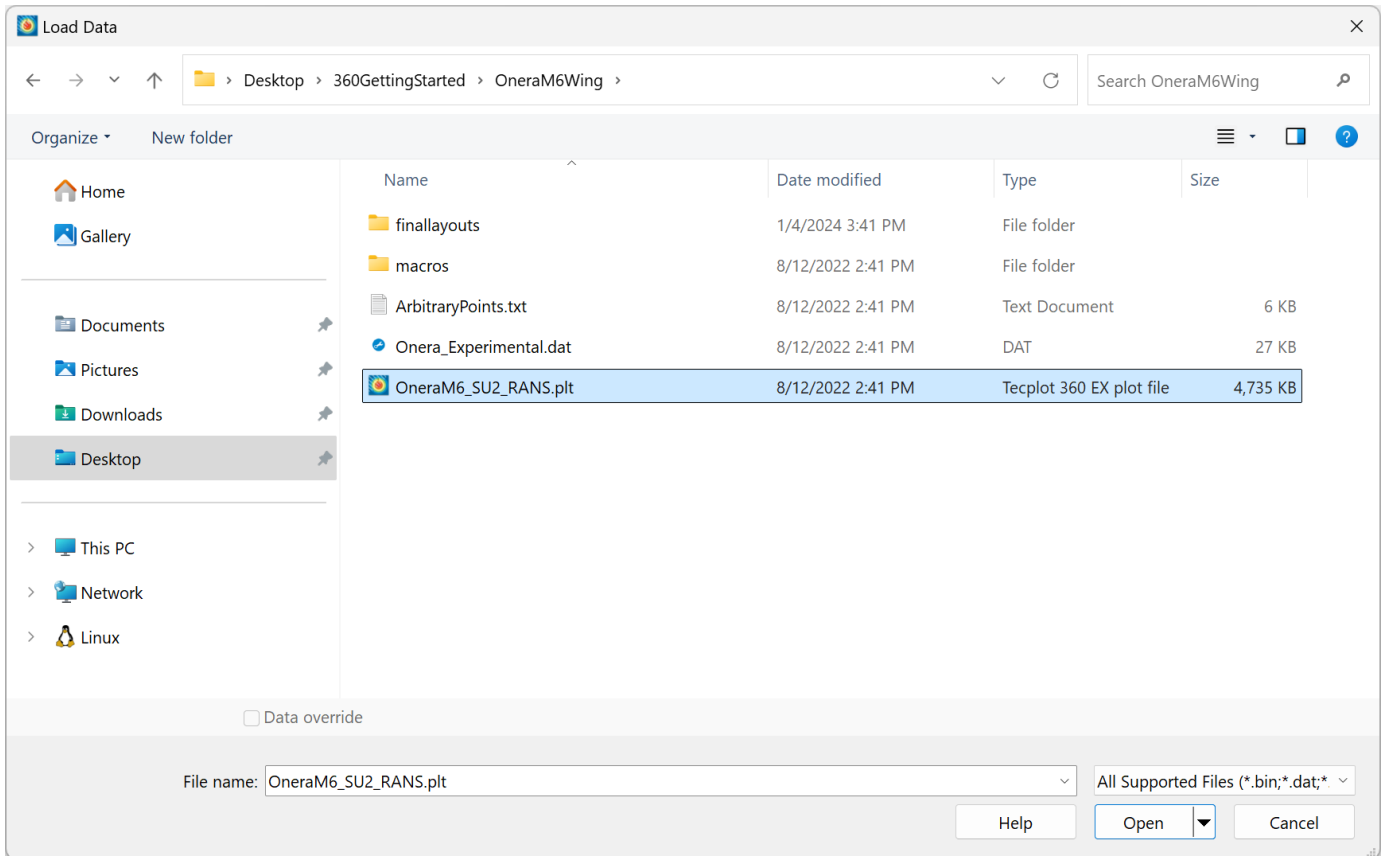

Navigate to your Tecplot 360 installation folder, then the **examples** folder, then the **OneraM6wing** folder. Then double-click the **OneraM6_SU2_RANS.plt** file to open it in Tecplot 360. (If you can't see this file, choose **All Files** in the menu at the bottom of the dialog.) The data file is opened and a 3D plot of the Onera M6 wing appears in the Tecplot 360 workspace, as shown here.

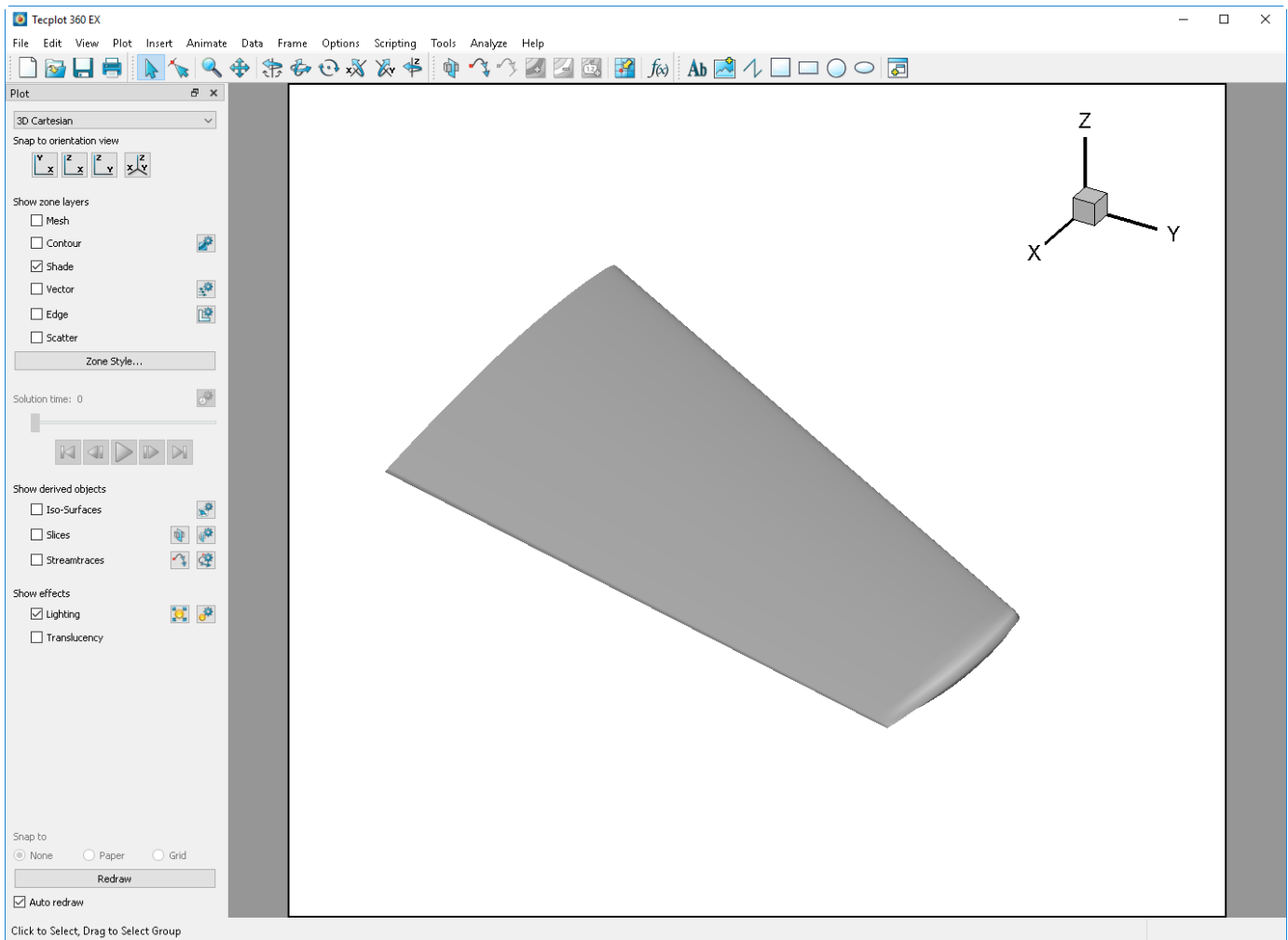

Step 2: Rotate the Wing

To rotate the view of the wing, hold down the Control key on the keyboard (Command on Mac), then hold down the right mouse button in the Tecplot 360 workspace and move the mouse to rotate the wing.

You'll notice that the range of rotation is not very great, making it hard to make significant changes to the view of the wing. This is because the rotation origin (the point around which rotation is performed) is not set anywhere near the wing. To change this, simply place the mouse pointer in the approximate center of the wing on the screen, then press the lowercase letter *o* (for *origin*) on the keyboard.

Then hold down the Control key (Command on Mac) and drag with the right mouse button again. You'll see it is now much easier to rotate the wing, since it rotates around its center.

Step 3: View Information About the Data Set

To see information about the Onera M6 data set, choose **Data Set Info** from the **Data** drop-down menu. The **Data Set Information** dialog, shown here, appears.

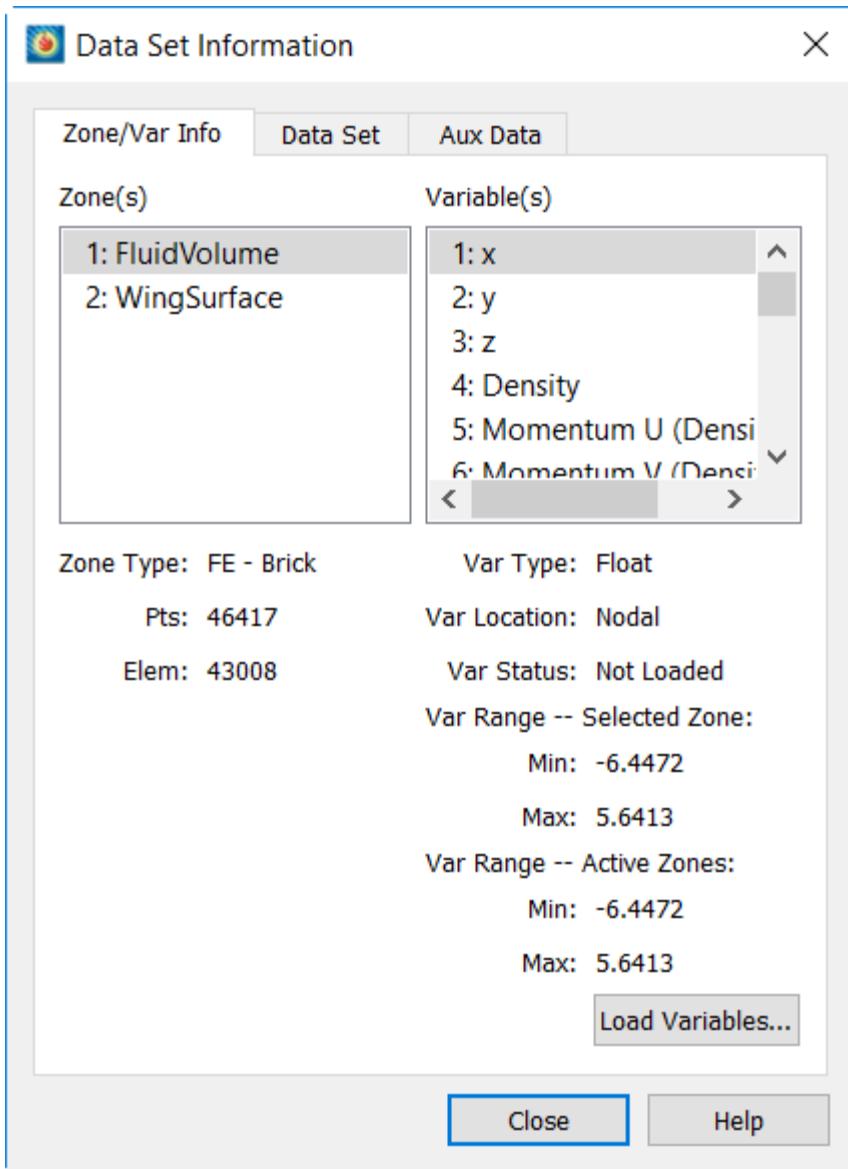

This dialog provides a wealth of information about the data set. The two lists at the top of the dialog show you the names of the zones and the variables in the data set.

The zones in this data set are:

FluidVolume

the air around the wing

WingSurface

the surface of the wing itself

You may wish to explore the other information in the dialog, which is divided into three pages. Click the **Help** button for more information about the information displayed on any page of the dialog. When you're finished, close the **Data Set Information** dialog.

Step 4: Disable Bounding Box for Fluid Volume Zone

As you rotated the wing in step 2, you may have noticed a dashed orange line swoosh by in the plot. We have caught a glimpse of it here.

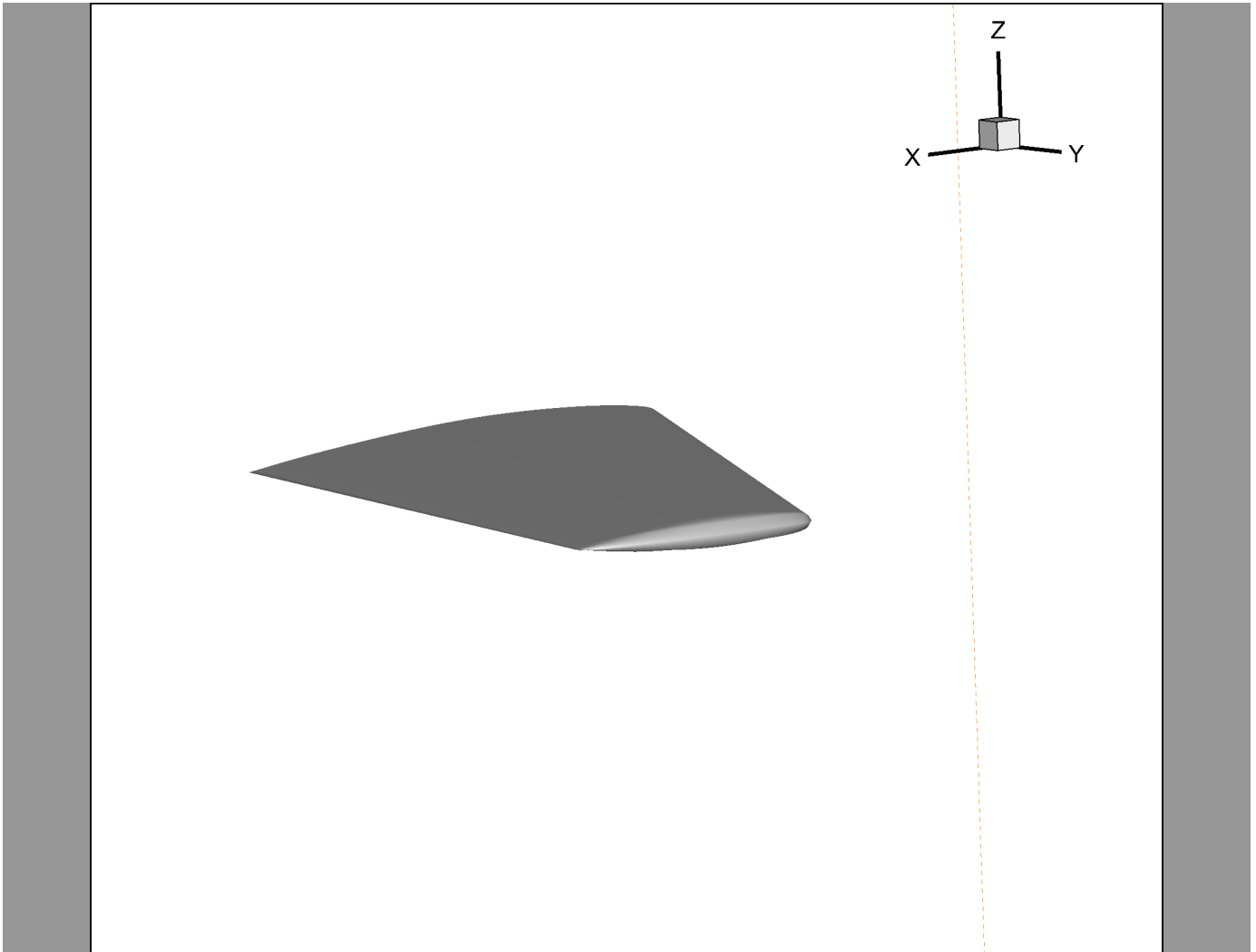

This is the bounding box of the **FluidVolume** zone, which represents the air around the wing. This zone does not have any style (that is, visual appearance) so it would normally be invisible. Tecplot 360 adds the dashed orange line so that you know it's there and can see its dimension.

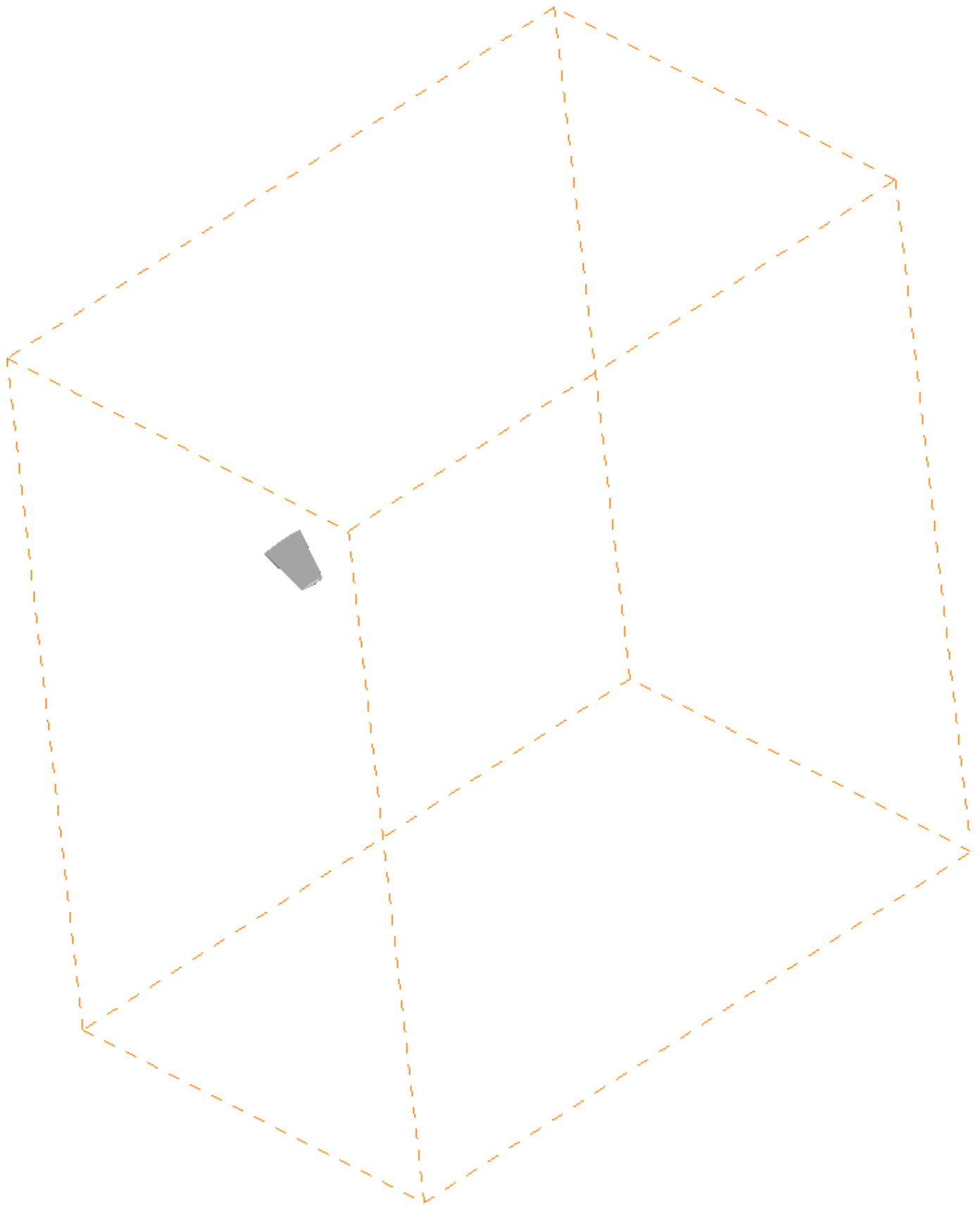

Choose **Fit Everything** from the **View** menu to see the full extent of the volume zone (see above). The wing is a tiny part of the data set! Choose **View>Last** to return to the previous view.

The bounding box does not add anything to the plot we're making, so let's turn it off. Choose **Show Bounding Boxes for Enabled Volume Zones with No Style** from the **Options** menu. The dashed orange line disappears.

Step 5: View the Mesh Using the Context Toolbar

To view the mesh for the **WingSurface** zone, right-click on the wing in the Tecplot 360 workspace. A context toolbar appears, as shown here.

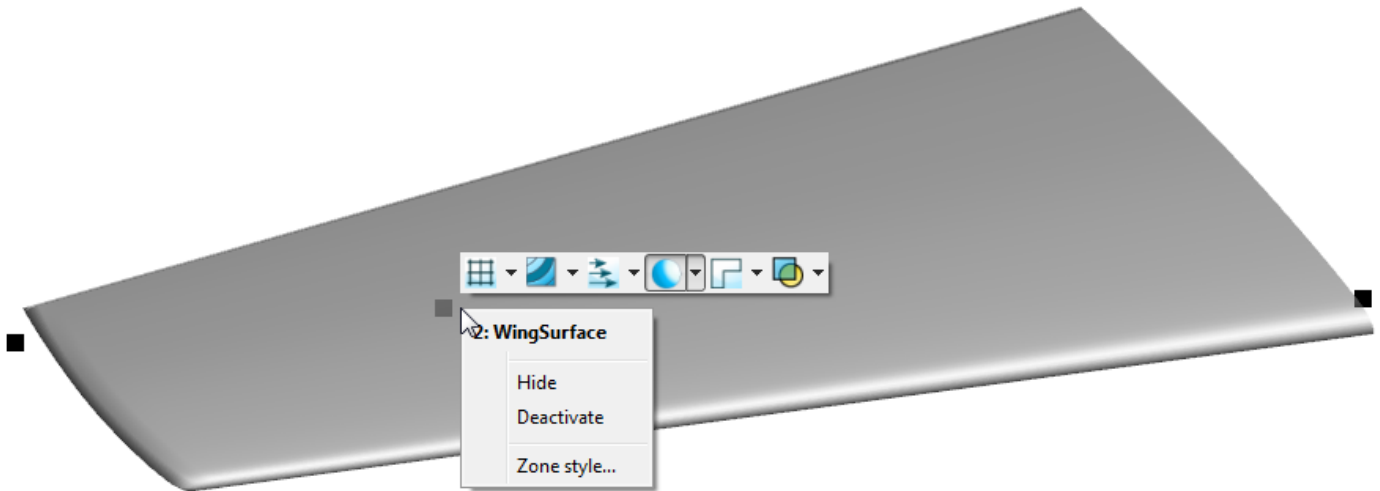

From left to right on this toolbar are buttons that allow you to turn on and off the mesh, contours, vectors, shade, edge, and translucency. Click the first button to display the mesh for the **WingSurface** zone, as shown here.

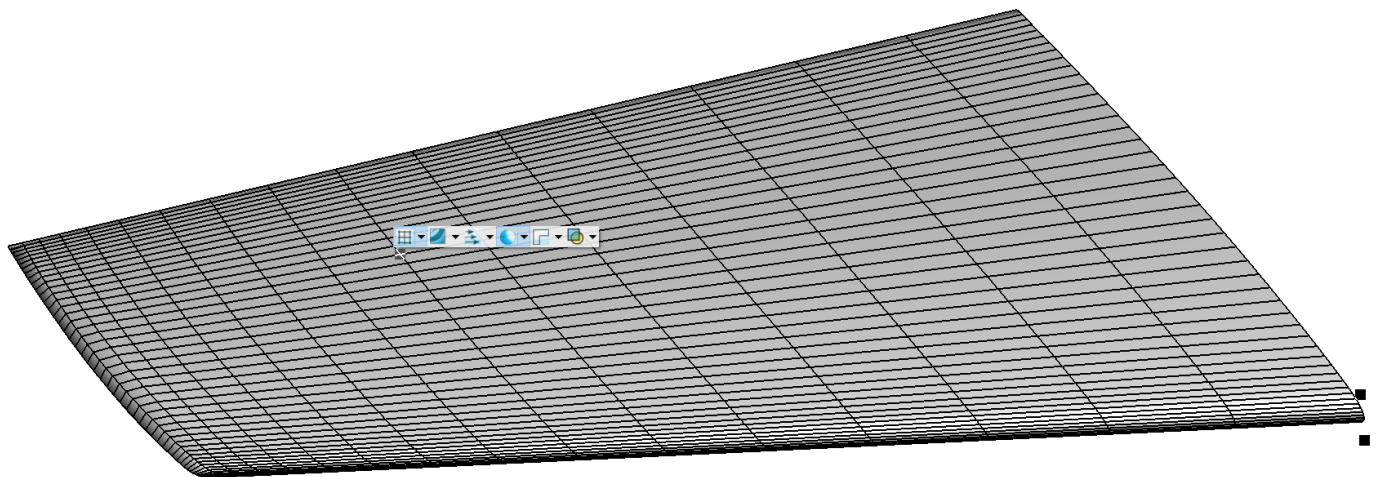

Step 6: Change the Mesh Color

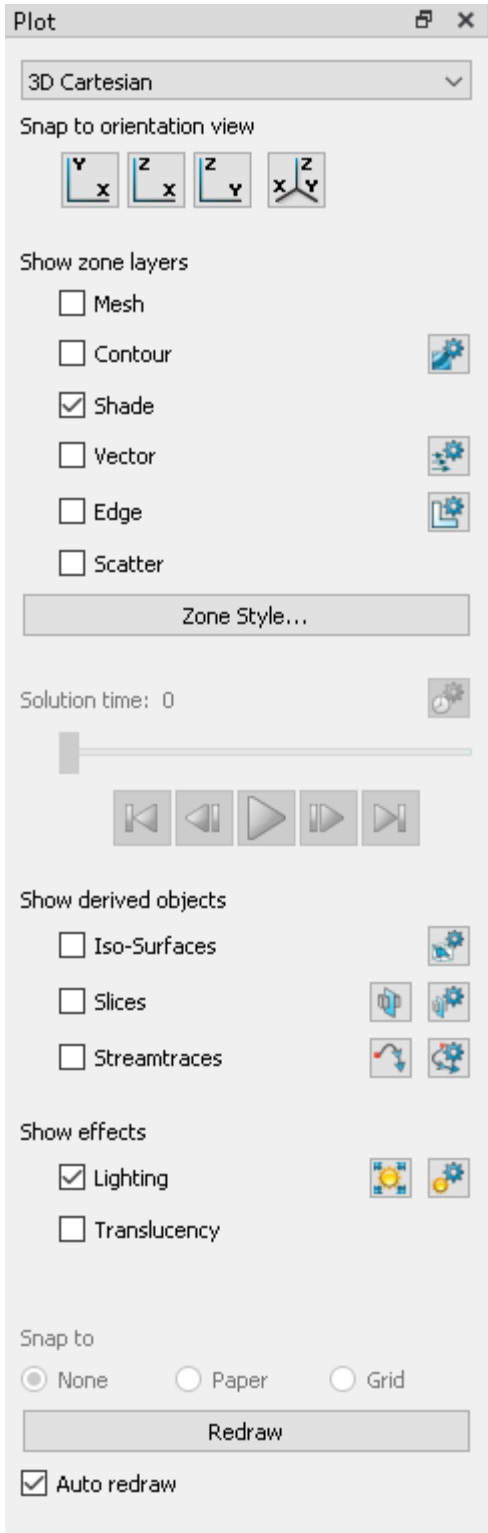

The top portion of the Plot sidebar lets you turn the layers of your plot on and off. The **Zone Style** button in this sidebar opens the **Zone Style** dialog, shown here.

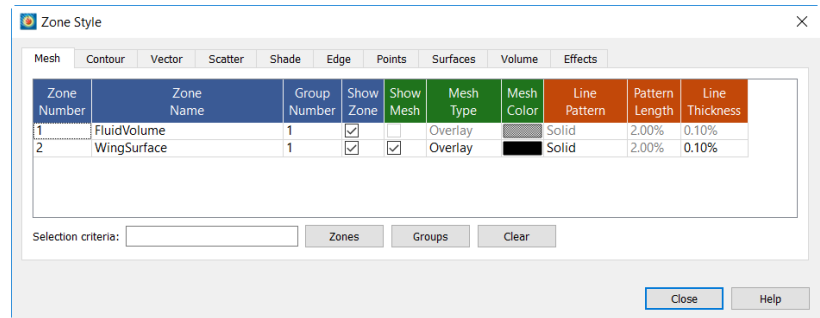

The Mesh Color column (right most green column) displays the color of the mesh for each zone, including **WingSurface**. Right-click the black color swatch to display the Color Chooser.

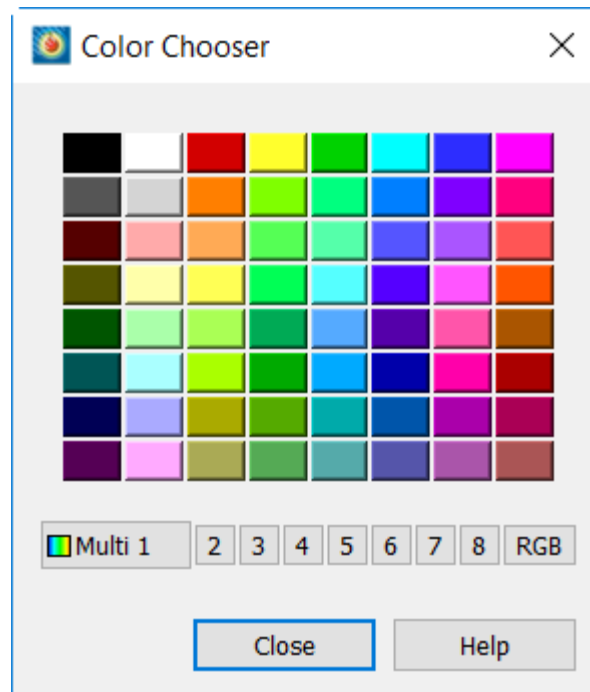

The Color Chooser lets you choose a single solid color, or, using the 1-8 buttons at the bottom of the dialog, you may choose to have the mesh colored using a contour, such as a gradient based on the value of some variable. (These numbers actually refer to Tecplot 360's eight contour groups, which associate variables and color maps. We will look at contours in more depth shortly.)

For now, let's choose a blue color for the mesh.

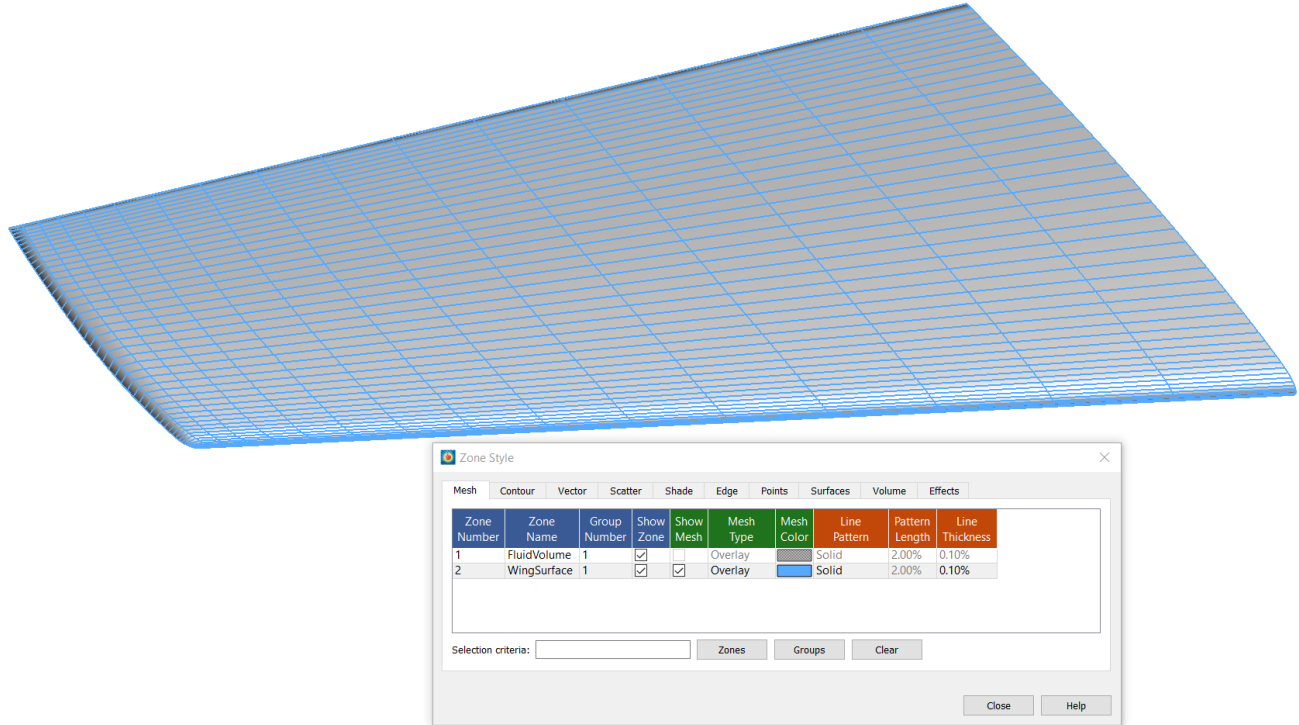

Close the Zone Style dialog, so that the wing surface is visible again.

Scenic Detour: Context Menu and Toolbar

Try right-clicking the wing. A context menu and toolbar appears, allowing you to make many of the same changes you can make in the **Zone Style** dialog—without needing to pull up the dialog. Here we are using the drop-down menu to the right of the mesh icon (the first icon on the toolbar) to choose the mesh color.

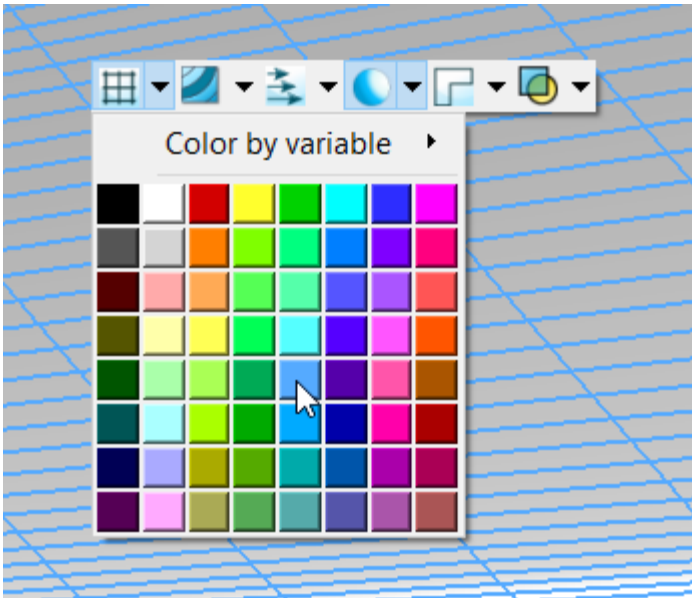

If you are changing the styles of many zones at once, it still makes sense to pull up the **Zone Style** dialog. For many other situations, the context menu and toolbar are faster.

We will use this context menu again in later steps.

Step 7: Set Up Contour Groups and Color Maps

The Onera M6 data contains a number of variables we might be interested in visualizing. Let's set up color maps so that we can see them as contours on the surface of the wing. First deactivate the mesh layer on the Plot sidebar, then activate the Contour layer in the Plot sidebar. Then click the  button next to the Contour checkbox to open the **Contour & Multi-Coloring Details** dialog, seen here.

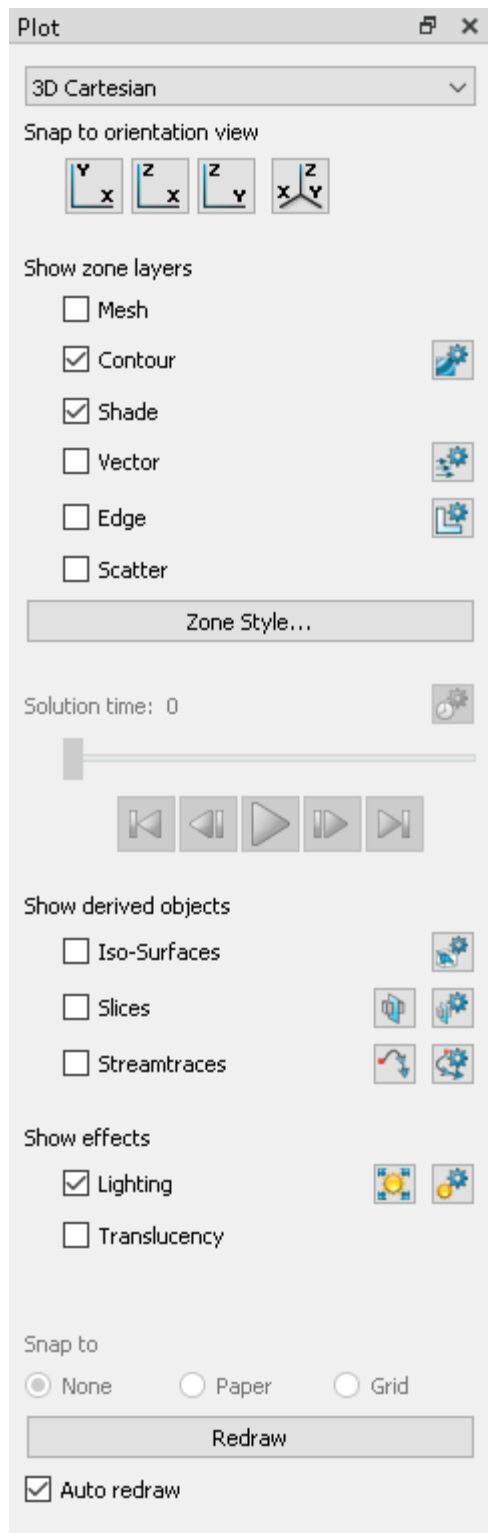
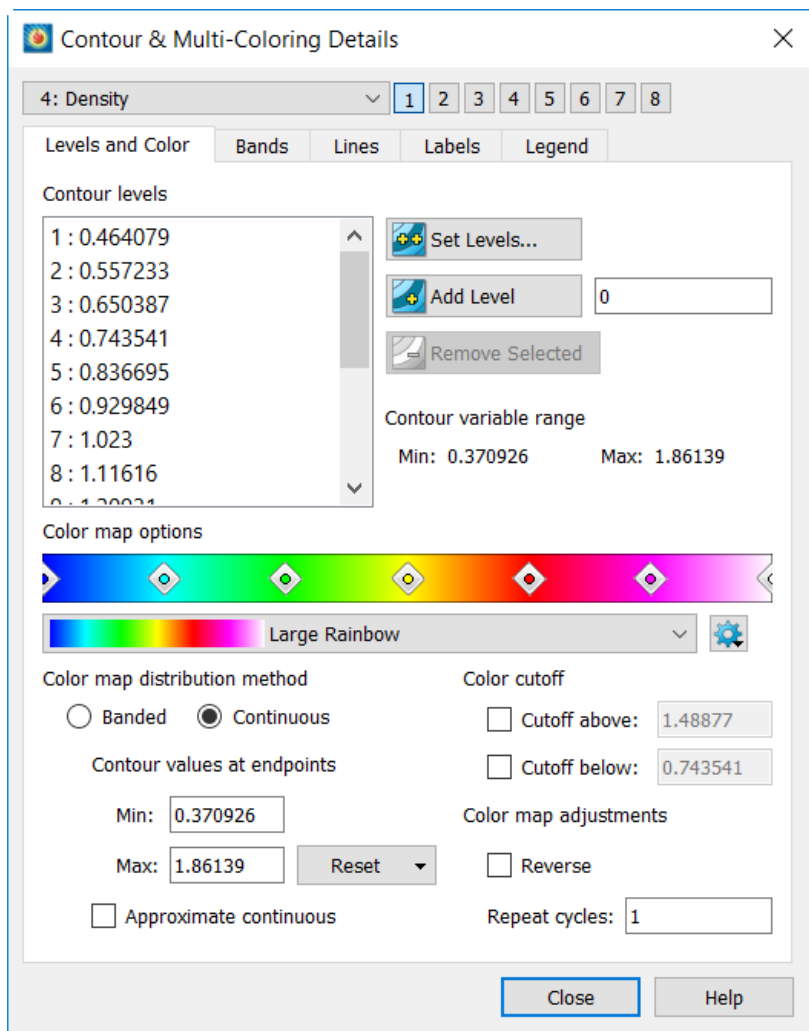

At the top of the dialog is a drop-down menu for choosing a variable. Next to this are eight numbered buttons, which specify the *contour group* you are editing. Each contour group has its own settings for this dialog. The contour group provides a way to associate a variable with a color map and other settings. The color map specifies how the zone will be colored according to the value of the specified variable.

For our tutorial, we will set up two contour groups. The first will display density with the Large Rainbow color map. The second will display the pressure coefficient using the Magma color map.

First, move the dialog so you can see most of the plot and the dialog at the same time.

1. Make sure contour group 1 is set at the top of the **Contour & Multi-Coloring Details** dialog.
2. Make sure the Density variable is chosen in the drop-down menu at the top of the dialog.
3. From the drop-down menu under the color map preview, choose Large Rainbow.

The dialog should appear as shown above. You should have noticed the plot changing as you made each change in the dialog, since the wing surface is already using contour group 1 by default.

Next, we'll set up contour group 2 for the `Pressure_Coefficient` variable.

1. Click 2 at the top of the **Contour & Multi-Coloring Details** dialog to choose contour group 2.
2. Choose the `Pressure_Coefficient` variable in the drop-down menu at the top of the dialog.
3. From the drop-down menu under the color map preview, choose Magma.
4. We also need to change the levels for the color map. Click the **Set Levels** button, then, in the **Enter Contour Levels** dialog, change the Minimum level to -1 and the number of levels to 21, as shown here.

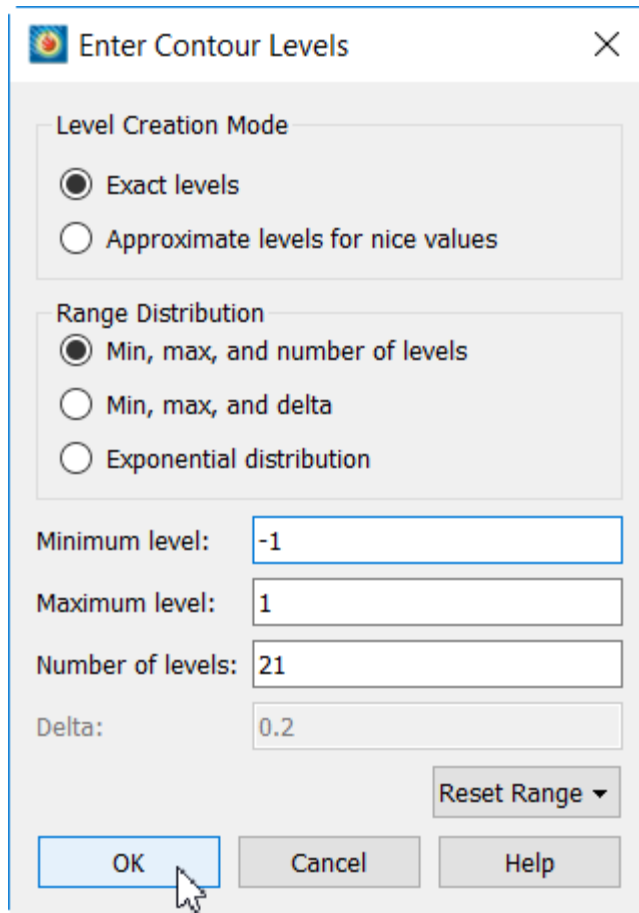

5. Click **OK** to close the **Enter Contour Levels** dialog.

The **Contour & Multi-Coloring Details** dialog should now appear as shown here.

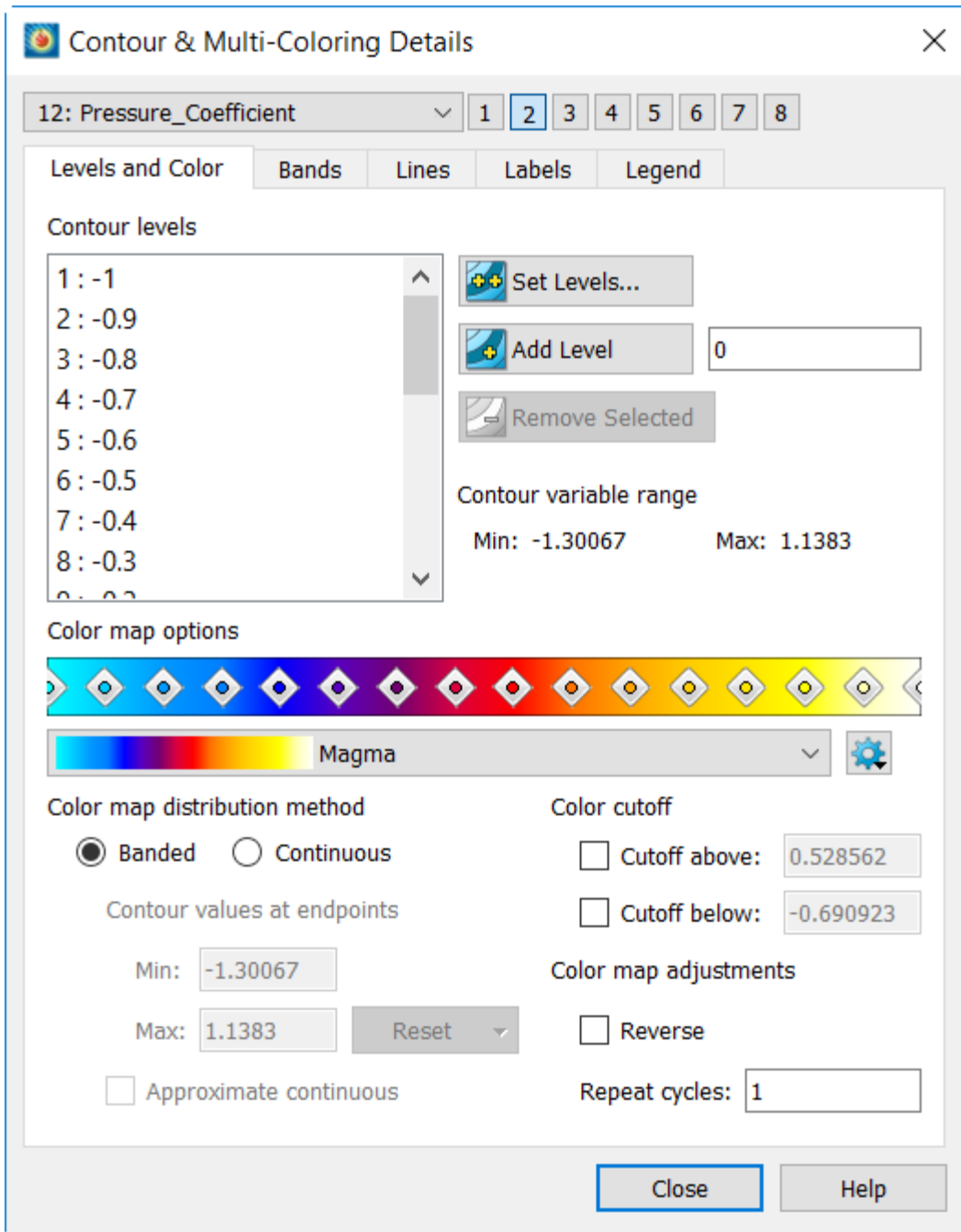

Step 8: Change Contour Group on Plot

Now that we've set up our contour groups, close the **Contour & Multi-Coloring Details** dialog. Ensure the Contour layer is checked on the Plot sidebar.

Now, we can change the contour variable displayed on the wing by right-clicking the wing, clicking the drop-down menu next to the contour icon in the context menu, and choosing contour group 2 **C2: Pressure Coefficient**.

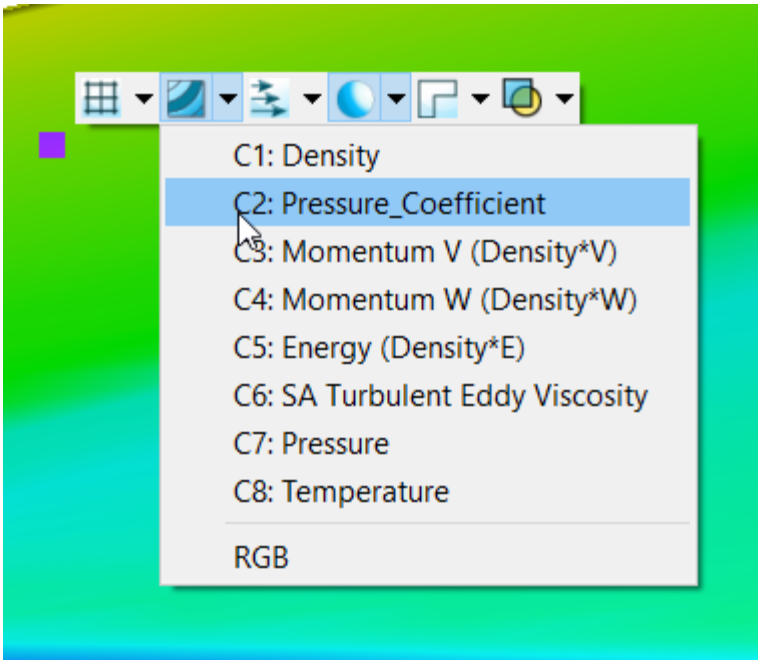

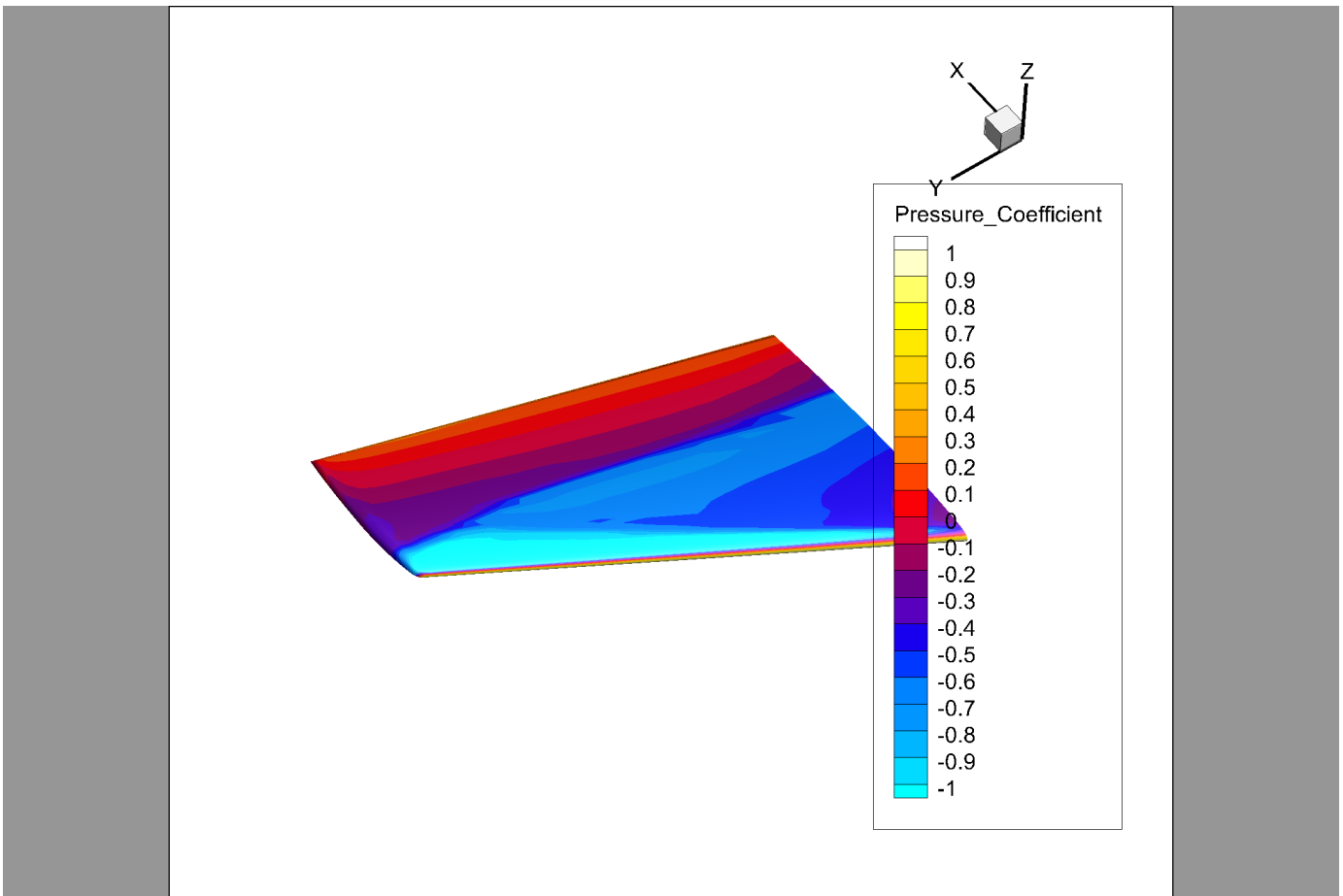

The plot so far is shown below.

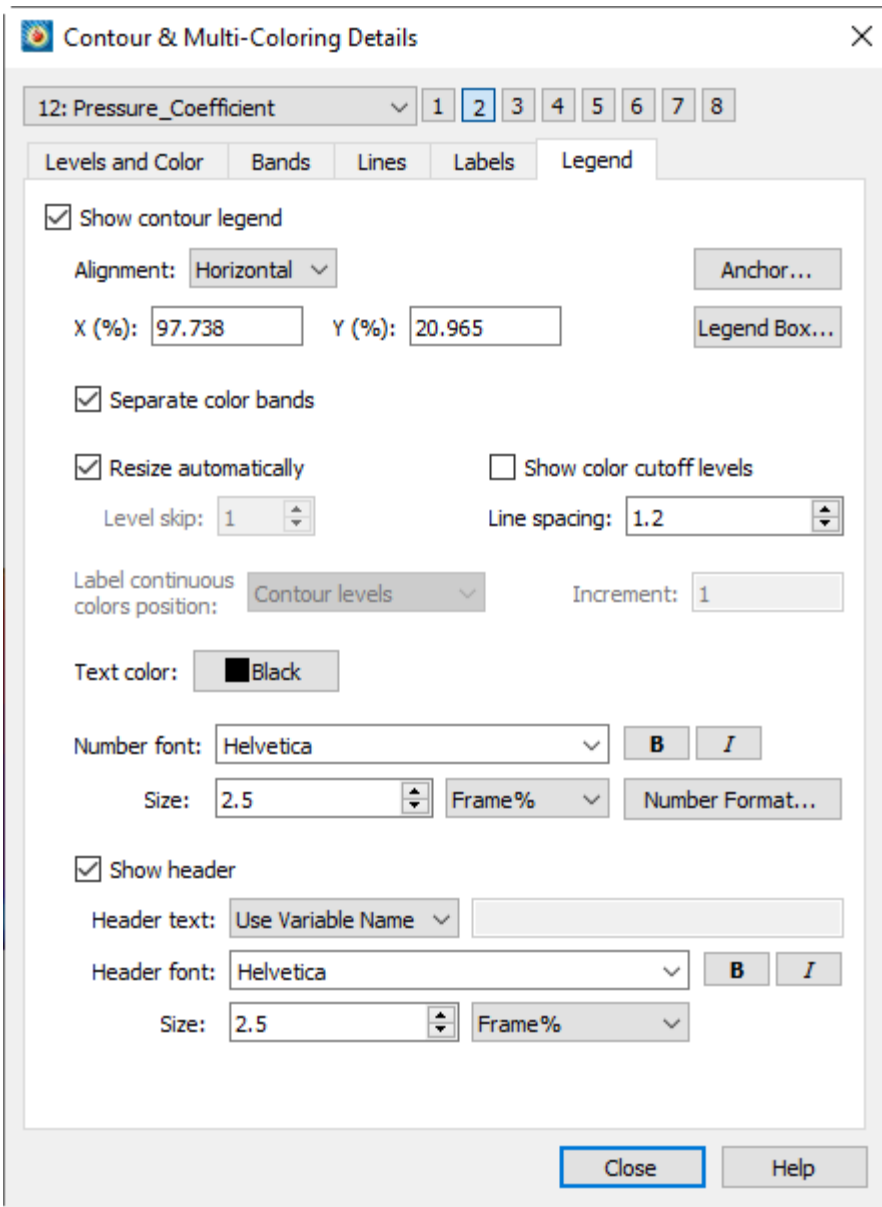

Step 9: Format Legend

That contour legend is useful, but it overlaps our plot. Double-click the legend title to open the Legend page of the **Contour & Multi-Coloring Details** dialog, shown here.



This is the same dialog we just closed a moment ago, just a different page. You can also get to it by clicking the  button next to Contour in the Plot sidebar, or by choosing **Plot>Contour/Multi-Coloring** from the Tecplot 360 menu bar.

In the **Contour & Multi-Coloring Details** dialog:

1. Change the alignment to horizontal
2. Turn on automatic resizing

The desired settings are shown above. Close the dialog after changing these settings.

Using the mouse, you may now drag the legend to the bottom of the plot. The final plot is shown here.

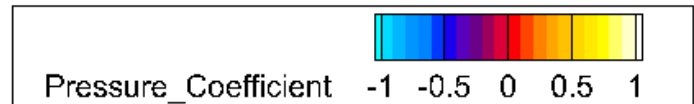
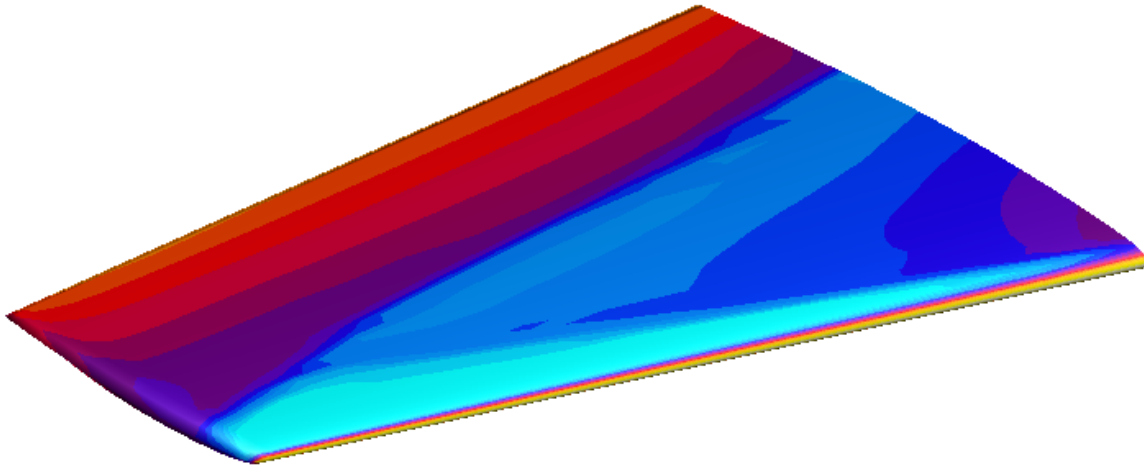
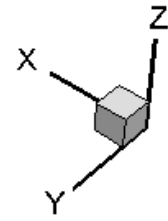

A Tecplot 360 layout (.lay) file containing a snapshot of the final result of this tutorial segment is in [OneraM6wing/finallayouts/ExtenalFlowVideo1.lay](#) in the **examples** folder in your Tecplot 360 installation folder. You can compare this with your result to see how you did.

You might even try saving a layout of your own work. Choose **File>Save Layout** from the Tecplot 360 menu bar, then navigate to the folder in which you want to save the layout, name it, and click **Save**.

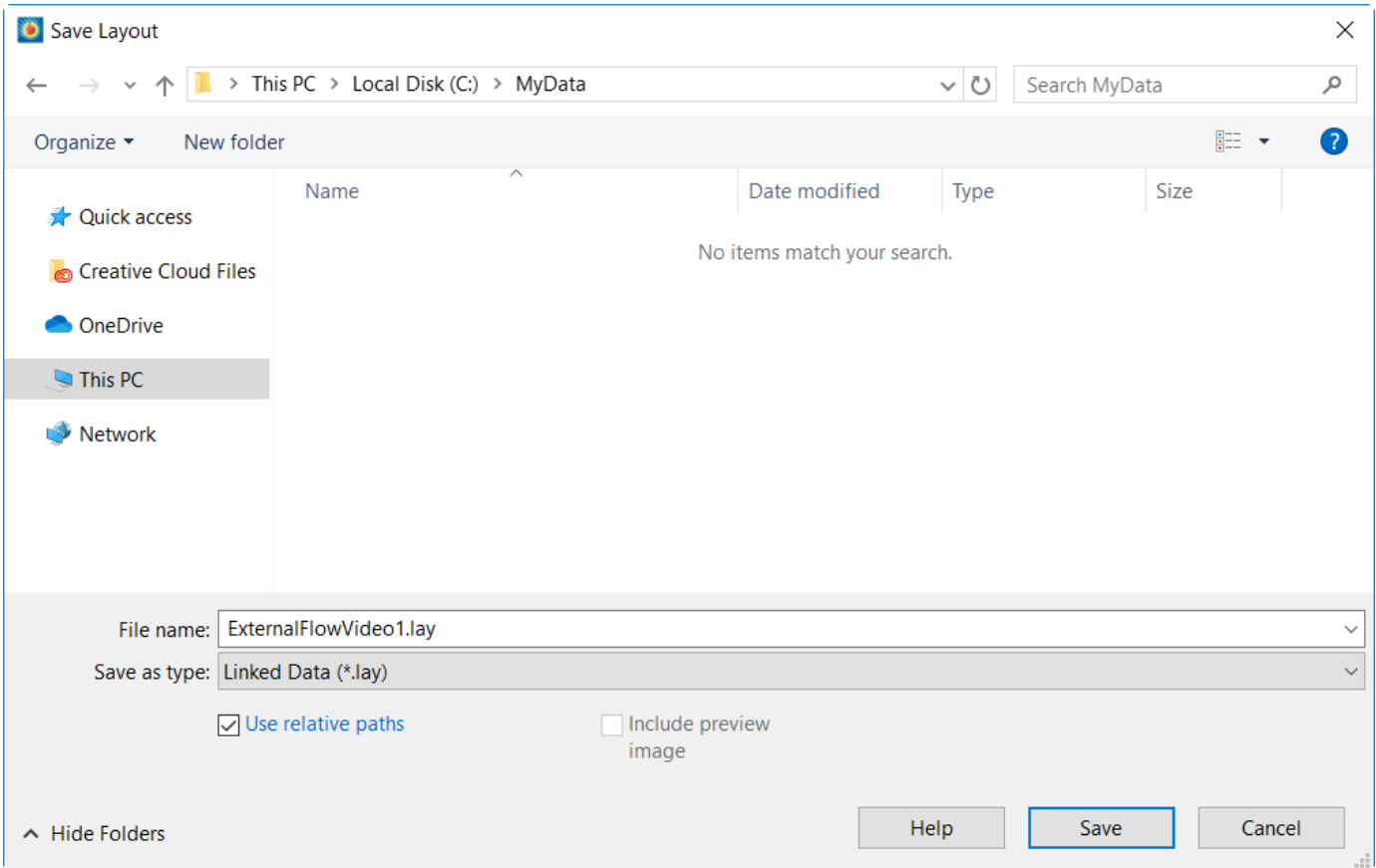

Exploring a CFD Solution

This segment of the External Flow tutorial covers slicing, streamtraces, iso-surfaces, and probing. These are tools you'll frequently use to get a closer look at the volume data in your solution.

We'll continue from where we left off at the end of the previous segment, with the coefficient of pressure visible on the surface of the wing. If you have closed Tecplot 360 since completing that segment, you can load the provided layout file [OneraM6wing/finallayouts/ExternalFlowVideo1.lay](#) in the [examples](#) folder in your Tecplot 360 installation folder, and continue from there.

Step 1: Add a Slice

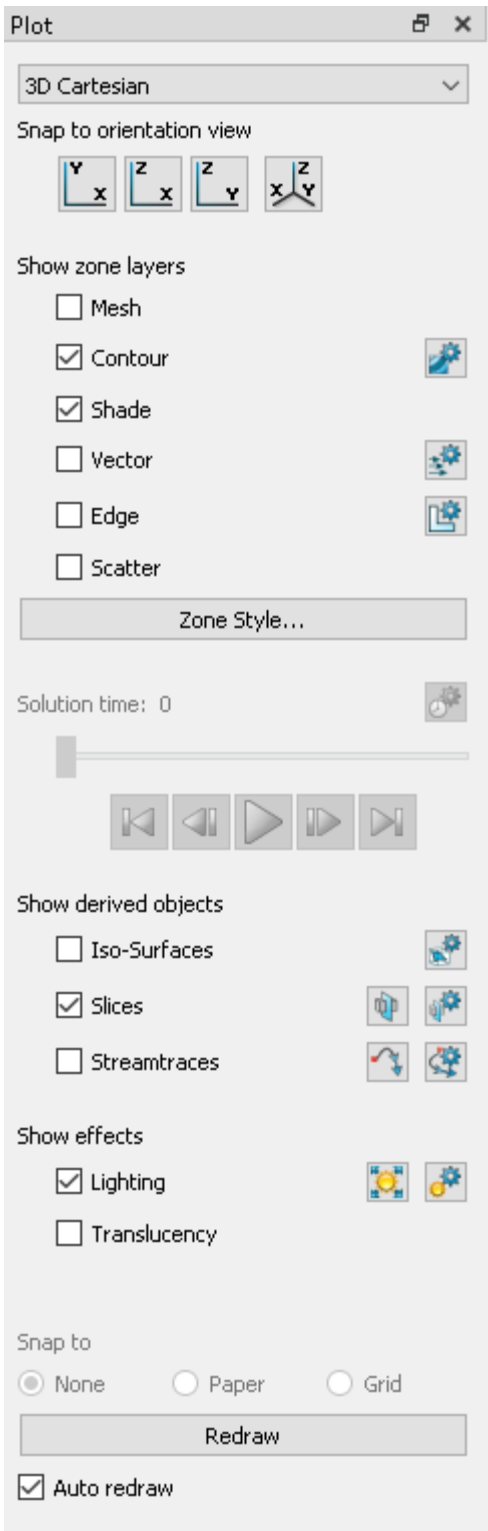

To add a slice, toggle on the Slices checkbox in the Plot sidebar. A slice appears through the volume zone.

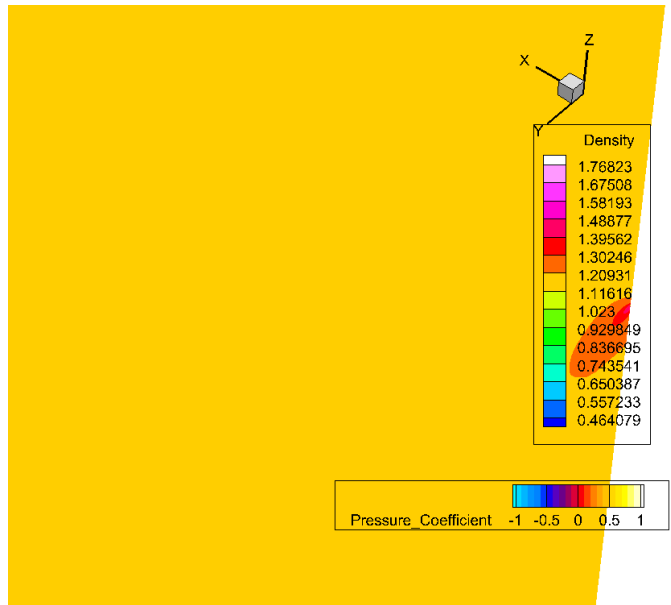

As we determined in the first segment of this tutorial, the volume zone is much larger than the wing. The slice through that zone, therefore, dominates the plot. That's why the screen suddenly fills with a nearly solid color (yellow in our plot; it might be green or a different color in yours).

The Density legend appears because this slice is using contour group 1.

To move the slice with the mouse, first click the slice tool in the Plot sidebar, next to the Slices

checkbox.

Then click the surface of the wing. (You probably can't see the wing at first, with the slice in front of it, but you can still click it even though you can't see it.) The slice moves to pass through the point that you clicked. You can see the slice at various positions in the following images.

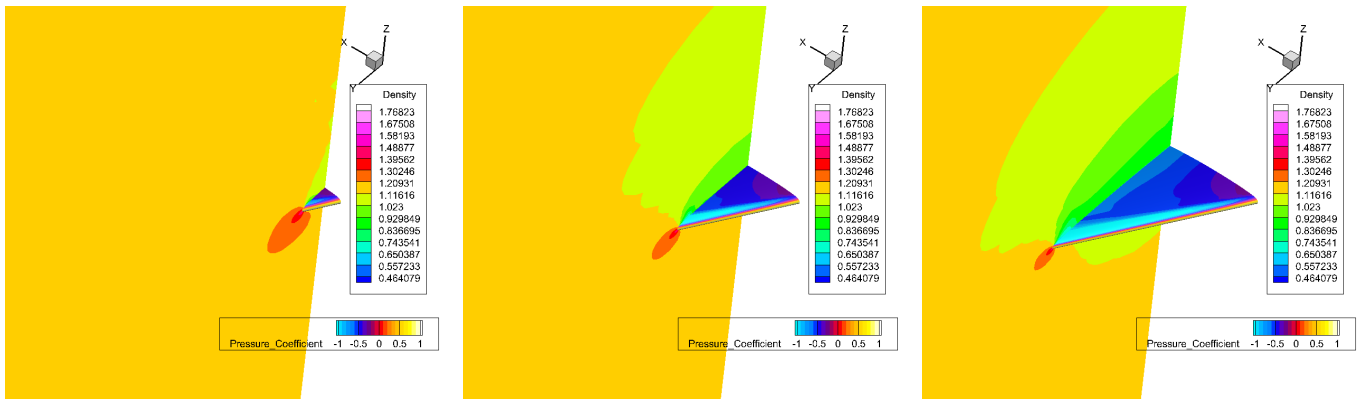

You can also *drag* the mouse on the surface of the wing to fine-tune the slice location. A blue-gray preview plane shows where the slice will be when you release the mouse button.

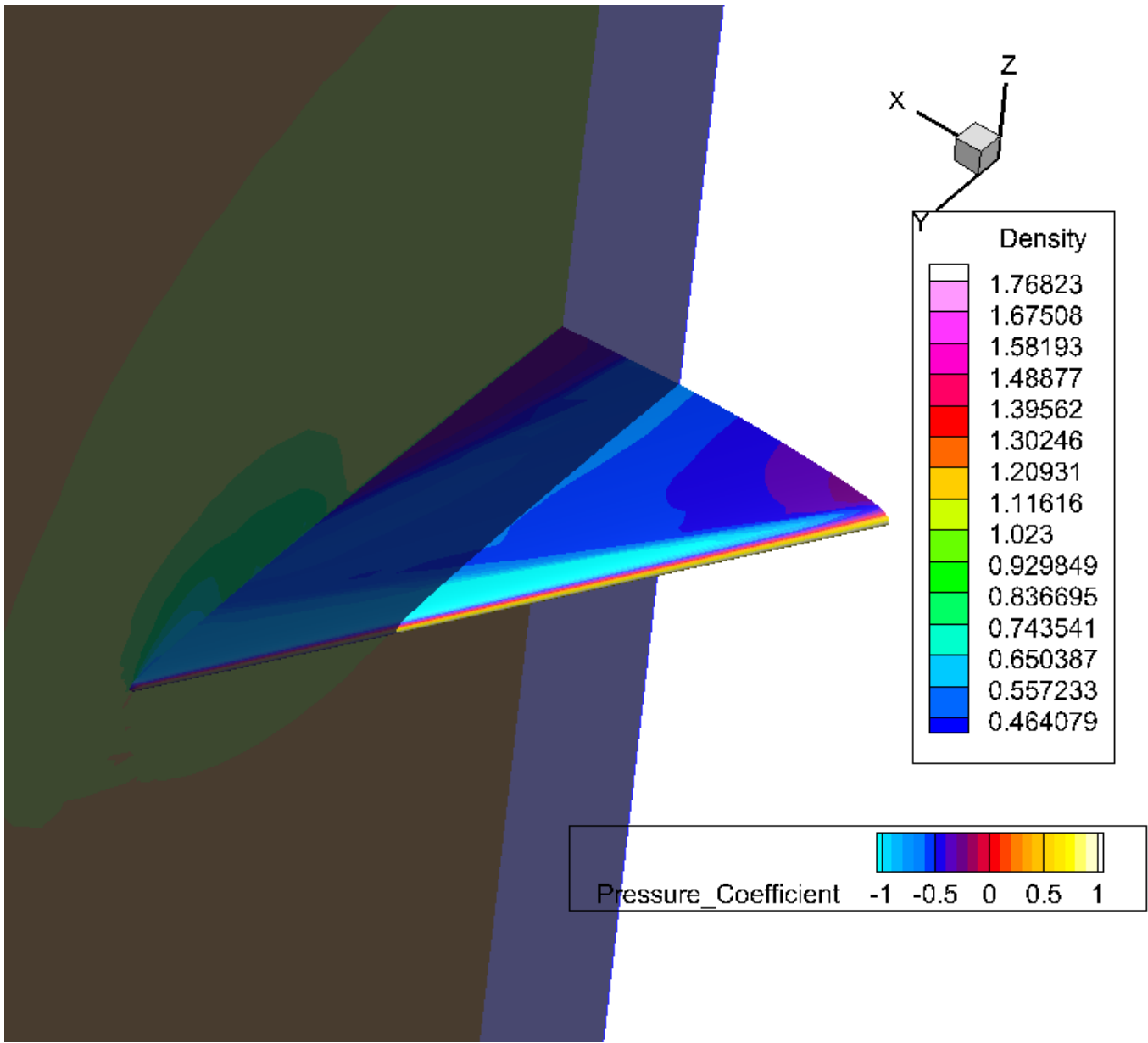

Step 2: Set Slice Details

Click the  button next to the Slices in the Plot sidebar to launch the Slice Details dialog.

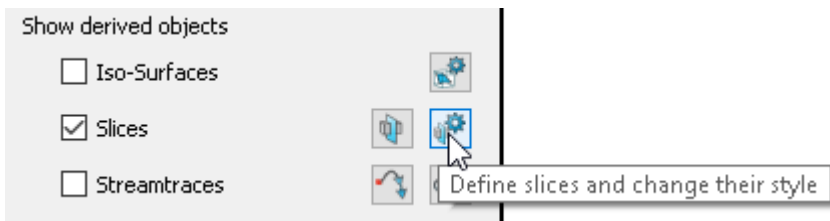

Let's spend a moment on the **Slice Details** dialog.

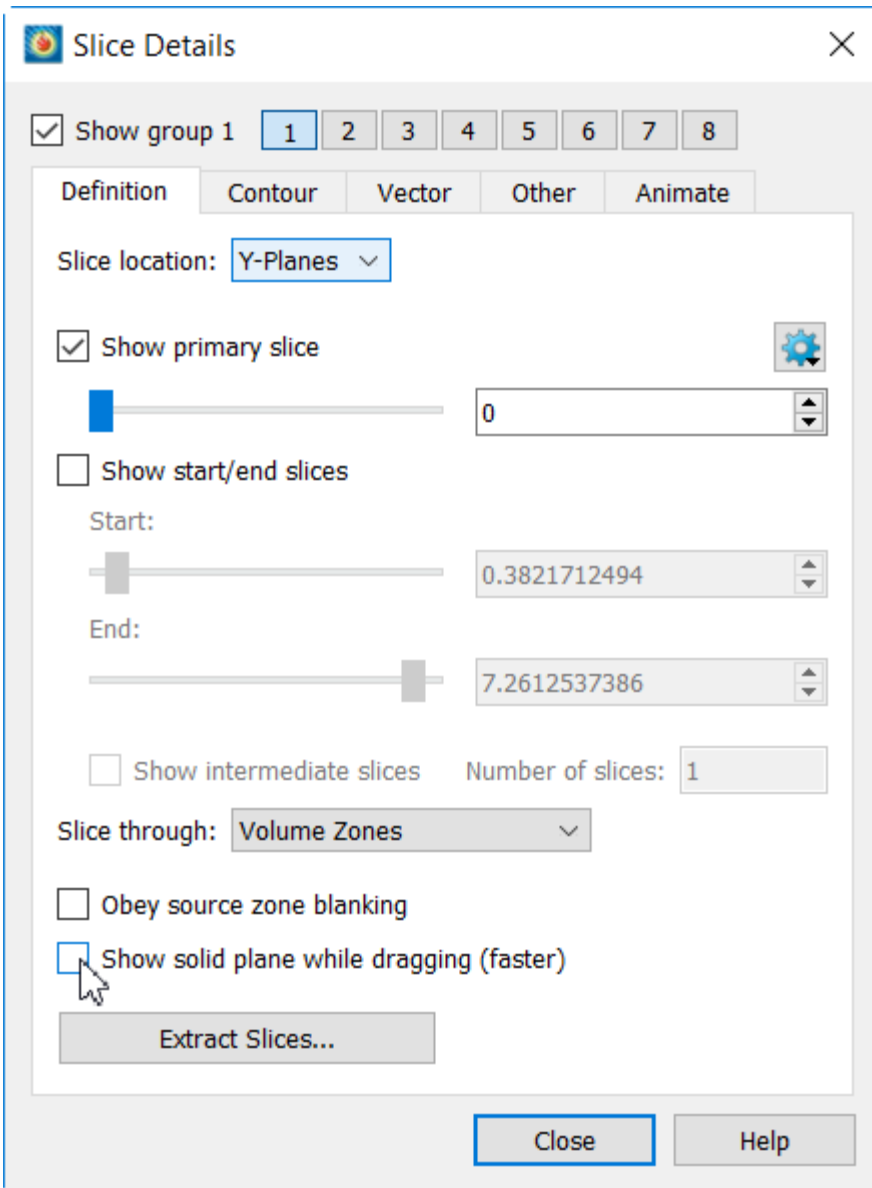

- There are eight buttons across the top, just as with the **Contour Details** dialog. This isn't a coincidence: Tecplot 360 supports eight slice groups, just as it supports eight contour groups. Each slice group uses the same normal and style, but can have its own positions. Various other settings are also unique to each slice group.

These numbered buttons tell Tecplot 360 what slice group you want to edit.

- You can manually change the slice orientation to a specific plane. Currently it is set to the X plane, which is the default. A Y plane slice is more useful here, since it shows the wake behind the wing. So let's change that.

The dialog also lets you choose an arbitrary slice orientation, though we won't use this capability in this tutorial.

- You can see that you can set up multiple slices by specifying a start slice, an end slice, and some number of intermediate slices. You can also choose what kind of data you want to slice through.

You can leave the **Slice Details** dialog open while you experiment with dragging the slice around. Notice that the slice position field in the dialog updates as you move the slice in the plot. (Most dialogs in Tecplot 360 can be left open while you work, updating whenever you change a plot by other means.)

Step 3: Show Contours

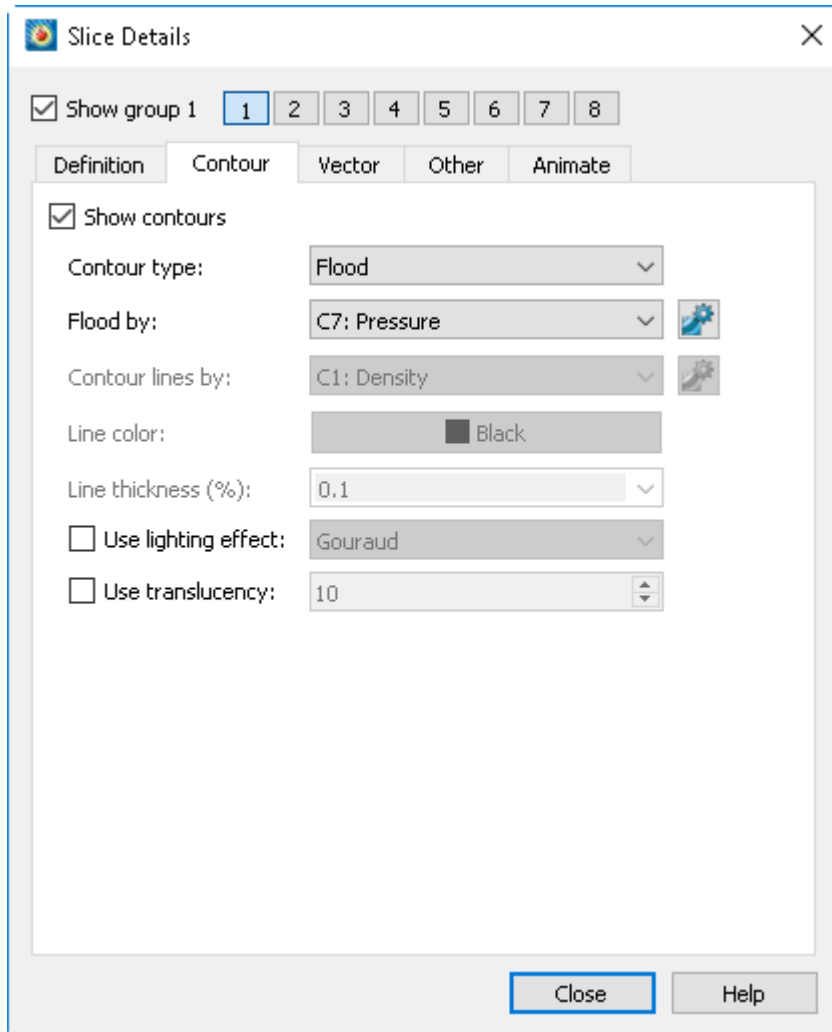

With the **Slice Details** dialog still open, let's take a quick detour to the Contour page of this dialog, which allows you to specify how the slice itself will be colored.

This ties back to the contour groups we discussed in the previous segment of this tutorial (see [Step 7: Set Up Contour Groups and Color Maps](#)). As a refresher, a contour group ties a color map to a variable, thereby establishing how an object in your plot will be colored based on the values of the selected variable.

On the **Contour** page of the **Slice Details** dialog, we can choose the contour group to be used for the slice, which in turn determines the color map and the variable used for the contouring. Flooding best represents continuous values, so we'll use the **Flood By** drop-down menu to choose the Pressure group.

If the variable we want to use isn't listed on the **Flood By** drop-down menu, we'll want to go to the **Contour and Multi-Coloring Details** dialog to set it up. Conveniently, that dialog can be accessed right

from the **Slice Details** dialog by clicking the gear icon next to the **Flood By** drop-down menu. Try it now if you like, just to see it's the same dialog, then close the **Contour and Multi-Coloring Details** dialog.

As shown here, we'll contour our slice by Pressure, which is contour group 7.

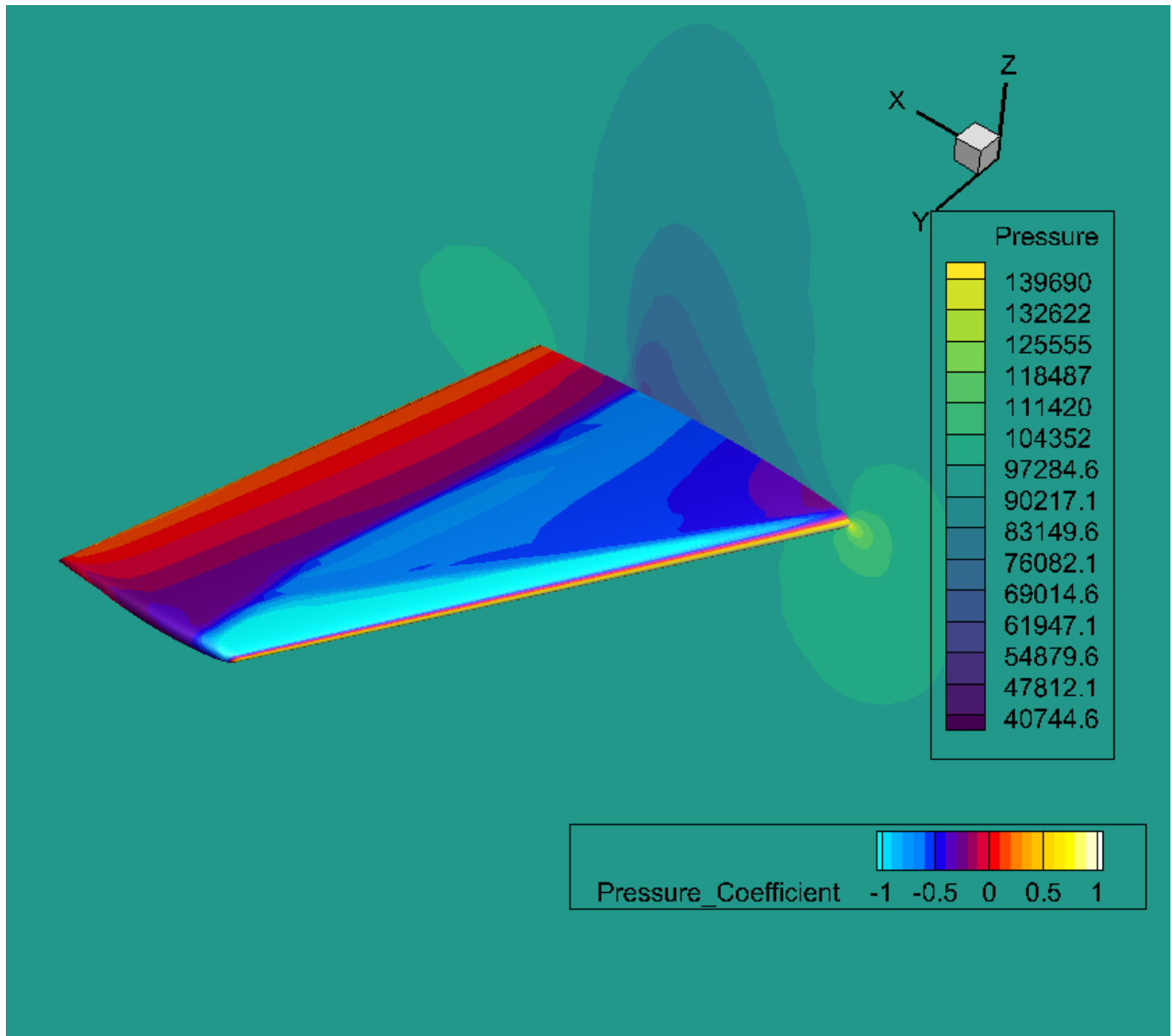

Scenic Detour: Creating Multiple Slices

Slices are great, so let's add more of them! We don't need to do this for the plot we're trying to make, which is why this section is labeled as a detour. You can skip it if you want.

1. On the Definition page of the **Slice Details** dialog, turn off **Show Primary Slice** and turn on **Show Start/End Slices**.
2. Rotate the plot so that you are looking nearly, but not quite, straight down on the wing from above. The slice, being perpendicular to the view, should be close to a line.

Reminder: To rotate the plot, hold down the Control key (Command on Mac) and hold down the right mouse button while moving the mouse. Hit o (the lowercase letter O) to set the origin of rotation to the mouse location.

Notice the *orientation axis* in the upper right corner of the plot, which makes it easy to tell when the plot's Z axis is pointing at you.

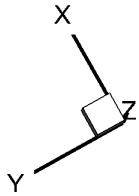

3. Using the Start slider, set the starting slice location to 0.
4. Set the ending slice location to the wing tip, around 1.16.
5. Turn on the Show Intermediate Slices checkbox and set the number of slices to 4. A total of six slices are shown.

Here's what the **Slice Details** dialog should look at this point, along with the plot.



Slice Details



Show group 1 1 2 3 4 5 6 7 8

Definition **Contour** Vector Other Animate

Slice location: Y-Planes ▾

Show primary slice 

 1.18

Show start/end slices

Start:  0

End:  1.16

Show intermediate slices Number of slices: 4

Slice through: Volume Zones ▾

Obey source zone blanking

Show solid plane while dragging (faster)

Extract Slices...

Close

Help

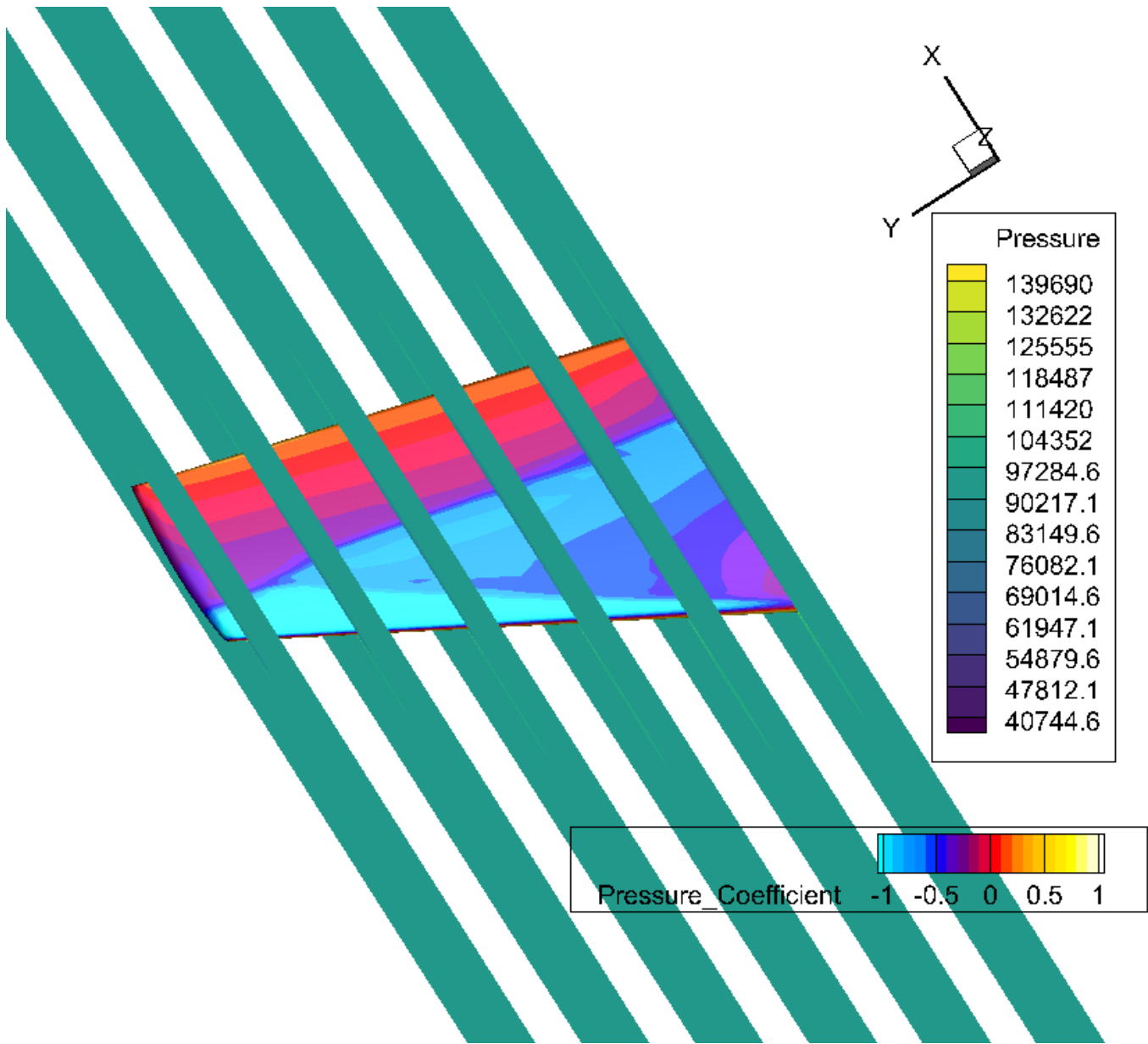

Step 4: Prepare for Streamtraces

Streamtraces are a useful tool for visualizing the flow around a surface. We'll try out three different types of streamtraces: volume lines, volume ribbons, and surface lines.

We only need a single slice for this, so if you followed the multiple-slice detour, go back to the **Slice Details** dialog, turn off Show Start/End Slices, and turn Show Primary Slice on.

We want our slice at the tip of the wing; that's where the pressure differential can cause vortex shedding. Enter 1.18 for the primary slice's location in the Slice Details dialog to place it close to the wing's tip.

The **Slice Details** dialog should now look as shown here. You can close the dialog at this point, as we won't need it for a while.

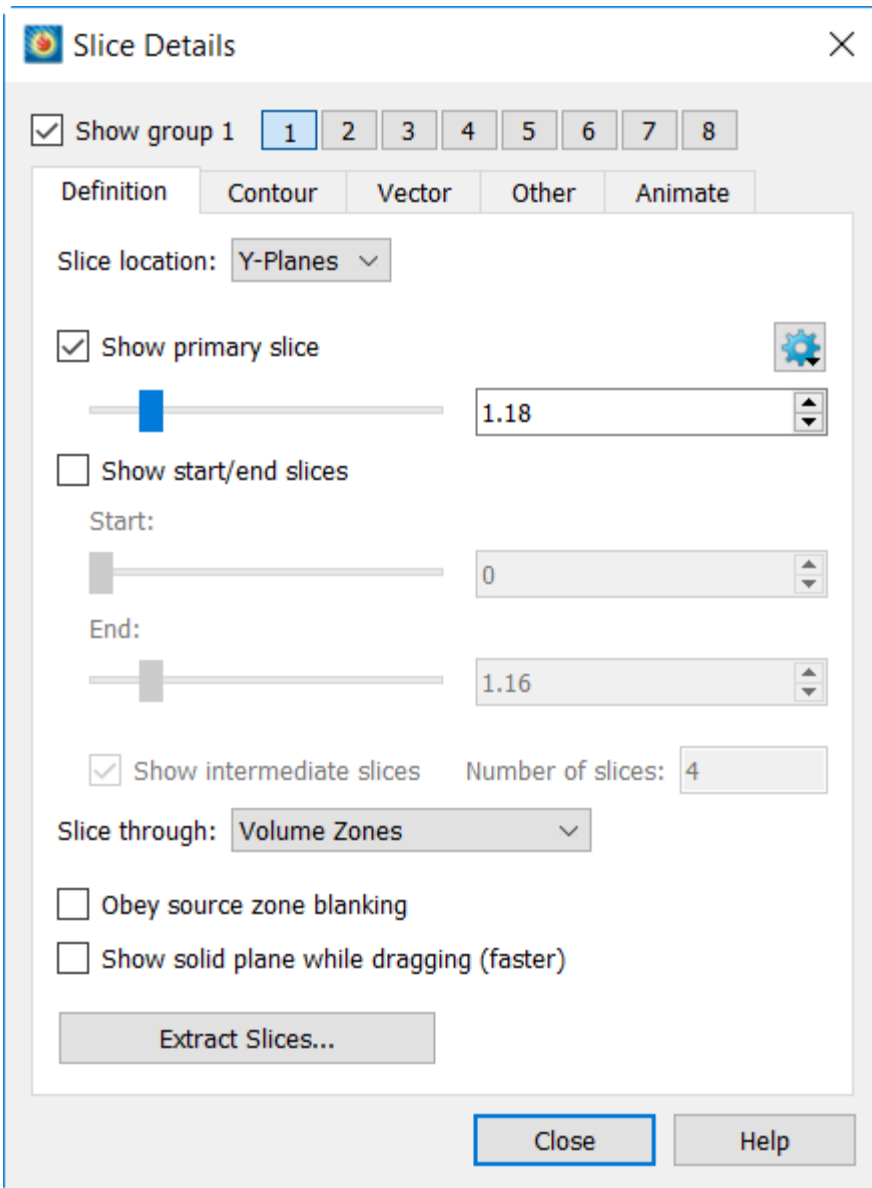

Now, rotate the wing so that the tip is pointing almost directly at us. (Hold Control, or Command on Mac, while dragging with the right mouse button.) The orientation axis in the upper right corner of the plot will help you get the wing pointed the right way. It should look roughly like the image below.

What are we looking at here? The green-blue background is our slice, and it's hiding most of the wing at this point, so we only see the wing tip.

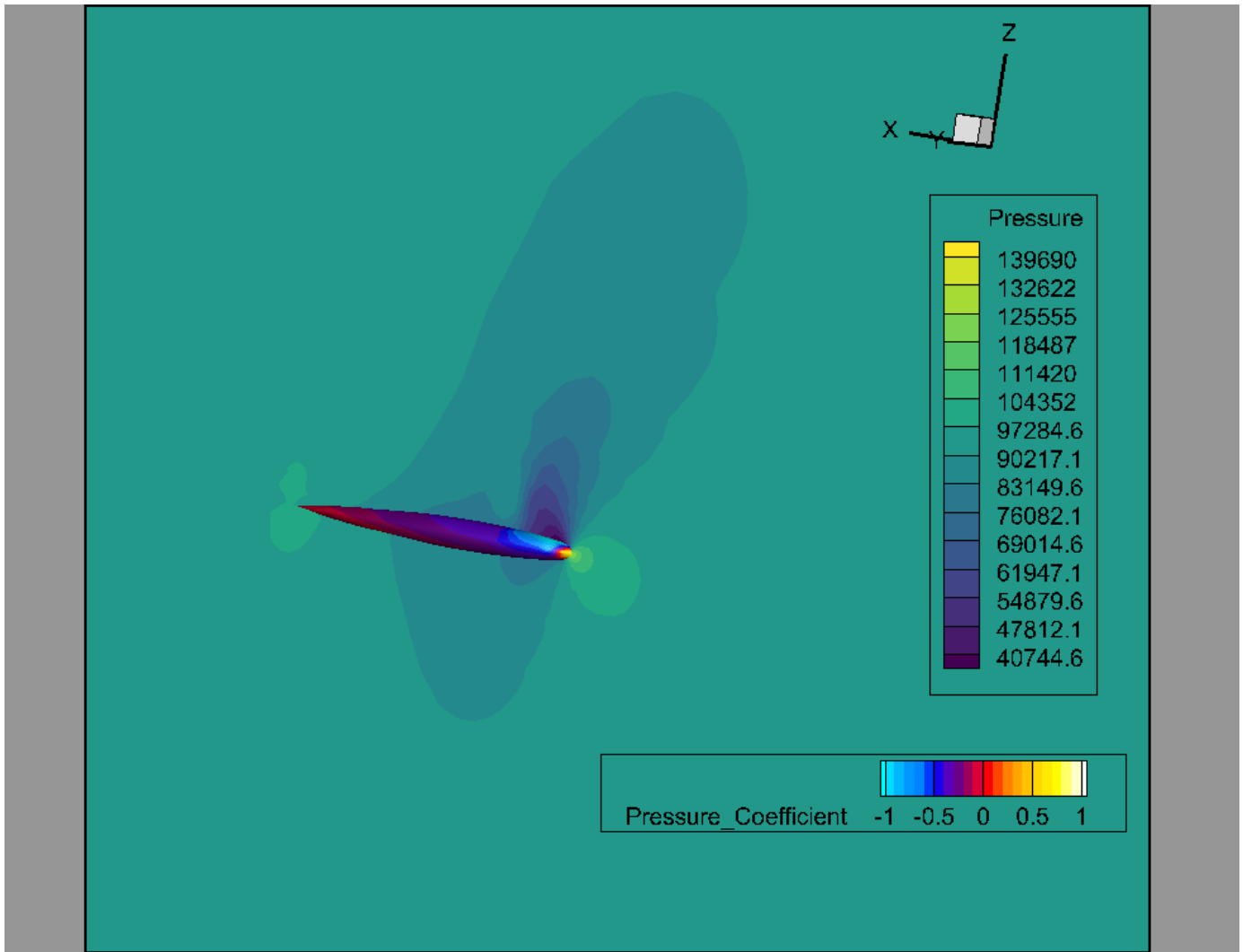

Last but not least, we can specify the vector variables that describe the velocity of the flow around the wing. If we don't do it in advance, Tecplot 360 will prompt us to choose the variables as we begin adding our streamtraces. However, just so we know where the feature is, let's do it ourselves now.

Choose **Plot** → **Vector...** from the menu bar or toggle on Vectors from the Plot sidebar. If you have not enabled vectors to this point, then the **Select Variables** dialog will appear. We actually don't have velocity values in our data, but we do have momentum, and the vector field for momentum is the same as for velocity. (Momentum is just velocity times density. In the next segment of this tutorial, you'll learn a technique you could use to calculate true velocity values.)

Therefore, for our purposes, we can use the momentum variables. So choose Momentum U, Momentum V, and Momentum W for the U, V, and W vector variables, respectively.

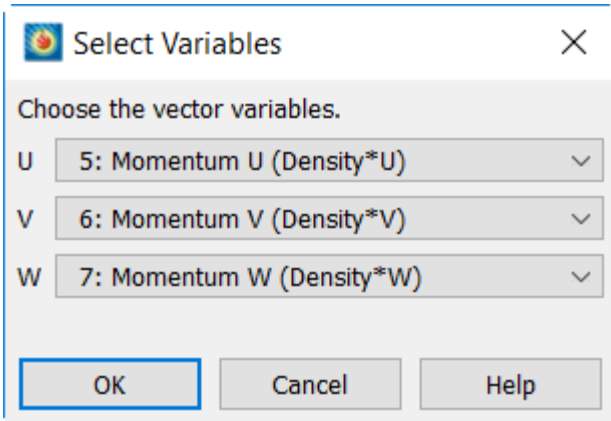

When the **Select Variables** dialog appears as shown here, click **OK**.

Step 5: Seed Streamtraces

Turn on the Streamtraces checkbox in the Plot sidebar, then click the Streamtrace tool button .

You can now place a line with the mouse and seed streamtraces evenly along the line. To place the line, click and hold the mouse button at the starting point, drag to the end point, and release the mouse button. Try drawing a roughly vertical line along the leading edge of the wing, as shown here.

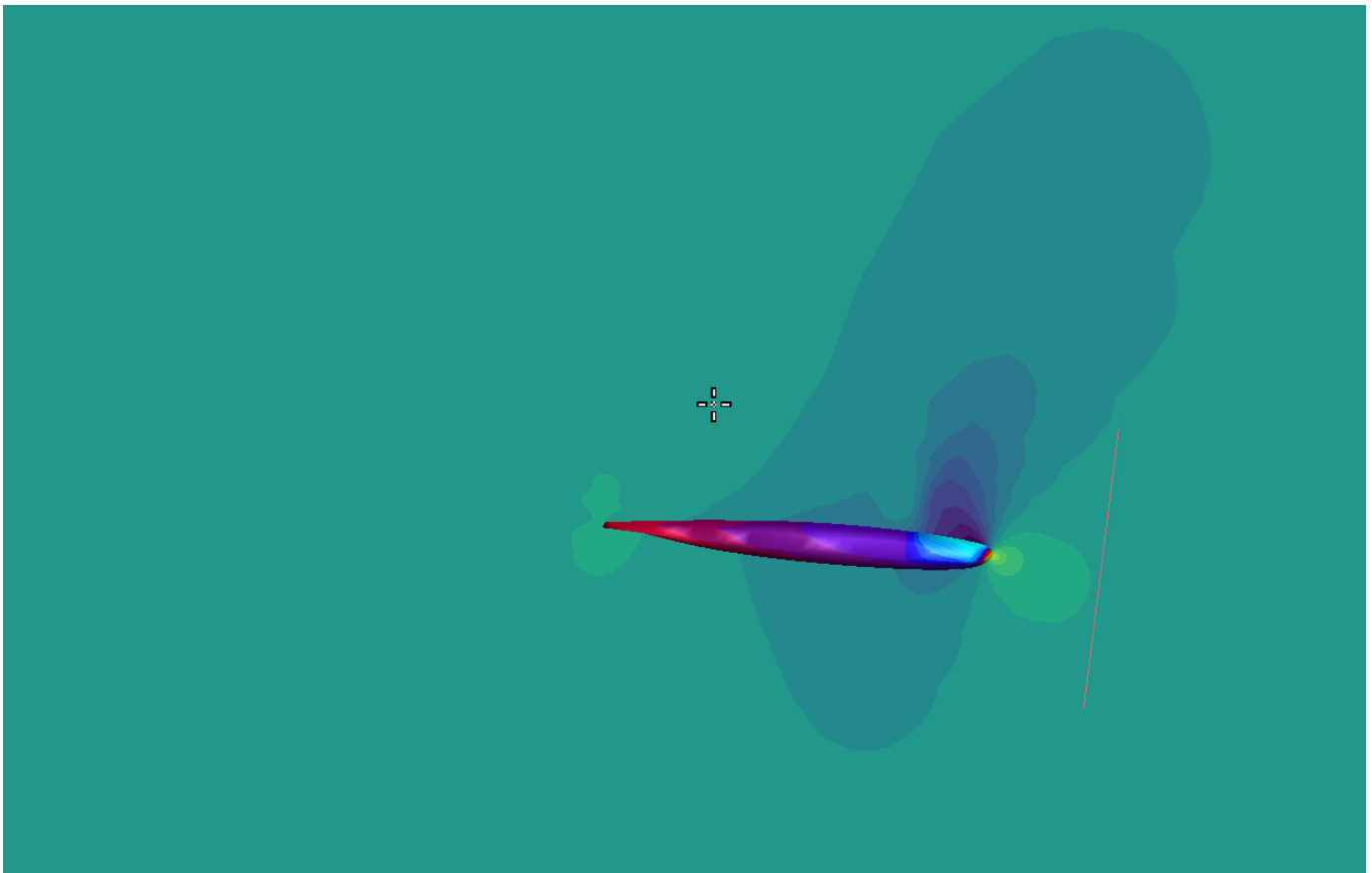

Tecplot 360 creates streamtraces showing the flow around the wing, as shown below. The streamtraces are generated by simulating the release of massless particles at the slice surface at equally-spaced points along the line (called "seeding") and calculating their path of travel based on the vector

variables that describe the flow.

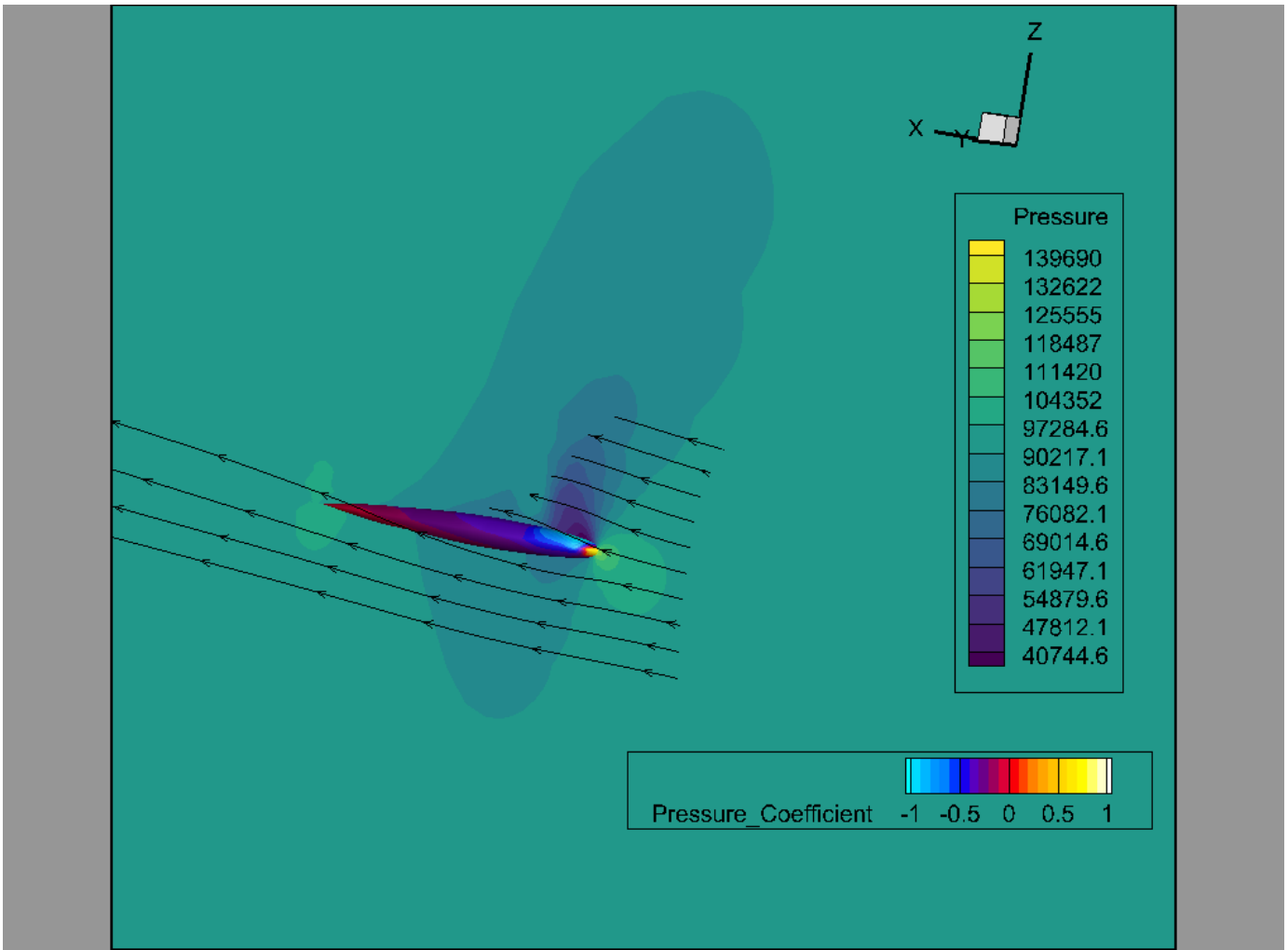

Some of the streamtraces are behind the slice. To see the streamtraces better, let's change the slice to be 40% transparent. To do this, right-click the slice and choose 40 from the right-most drop down menu in the context toolbar.

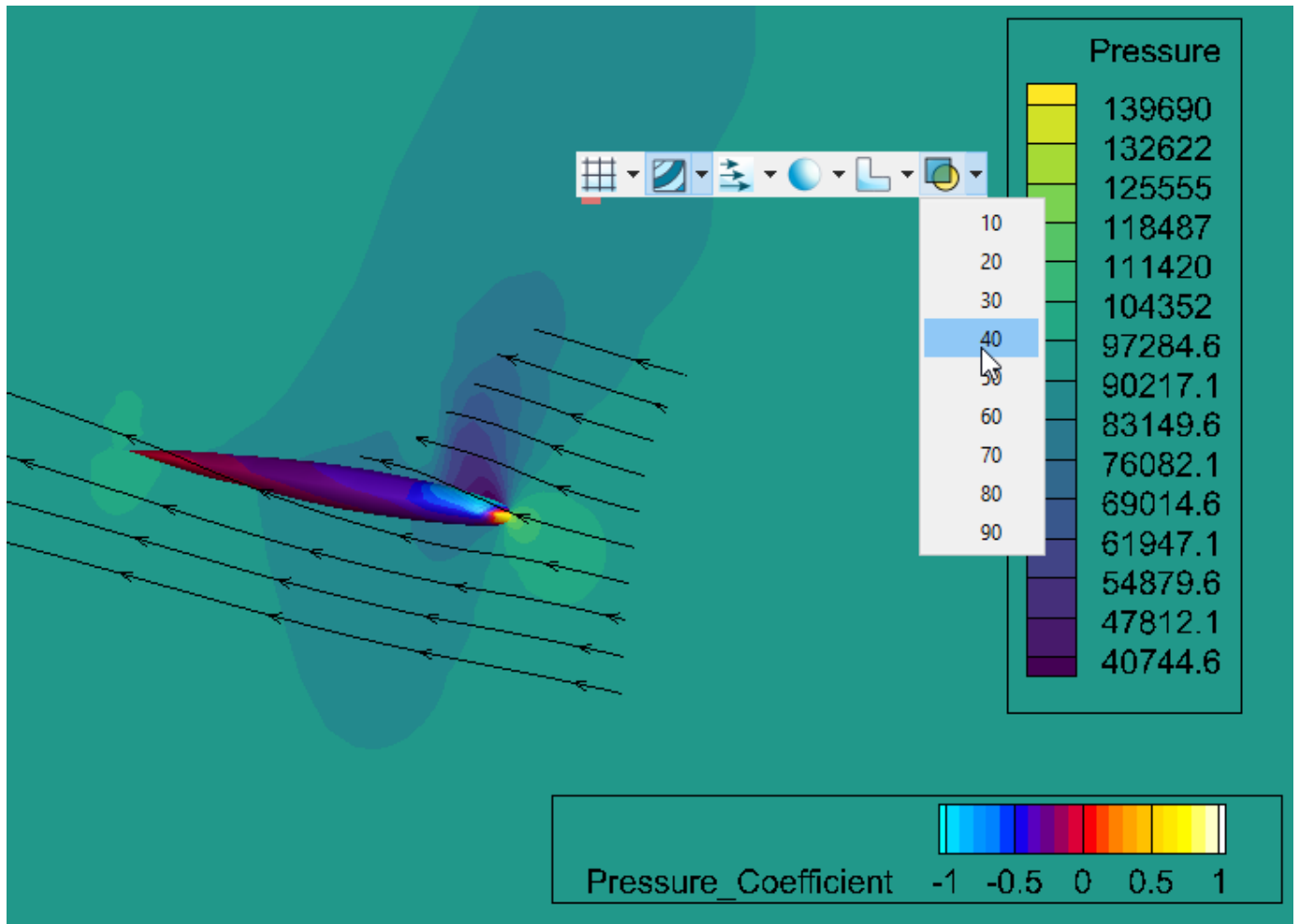

Now, rotate the plot in three dimensions to better see the streamtraces and the wing. A possible result is shown below.

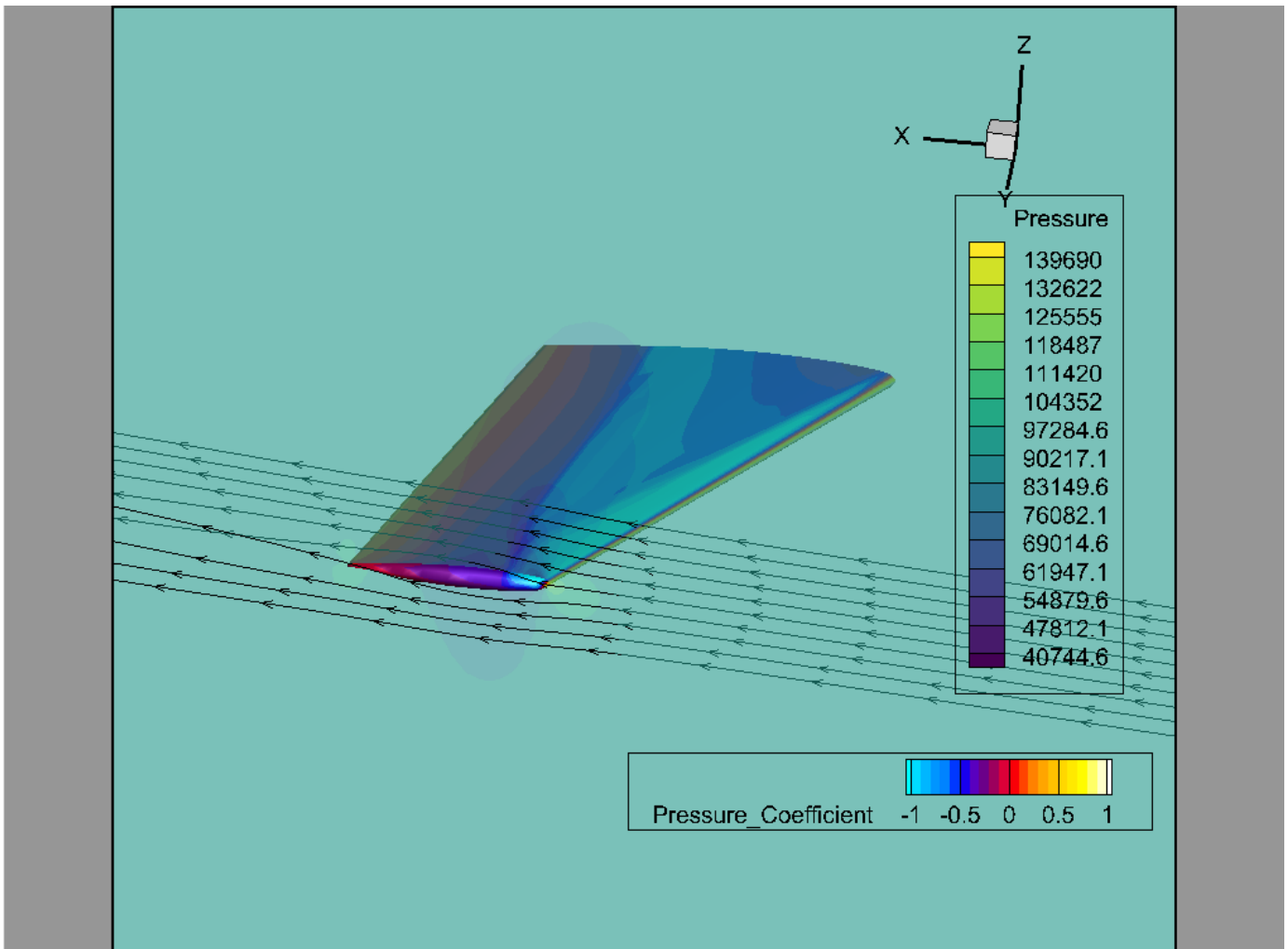

Step 6: Seed Volume Ribbons

By default, streamtraces are simple lines with arrowheads. Ribbons can allow us to see the flow better because they show local twist using a 2D surface. Here's how to switch to volume ribbons.

1. Open the Streamtrace Details dialog by clicking the  button next to Streamtraces in the Plot sidebar. Make sure the Placement page is active using the tabs at the top of the dialog.

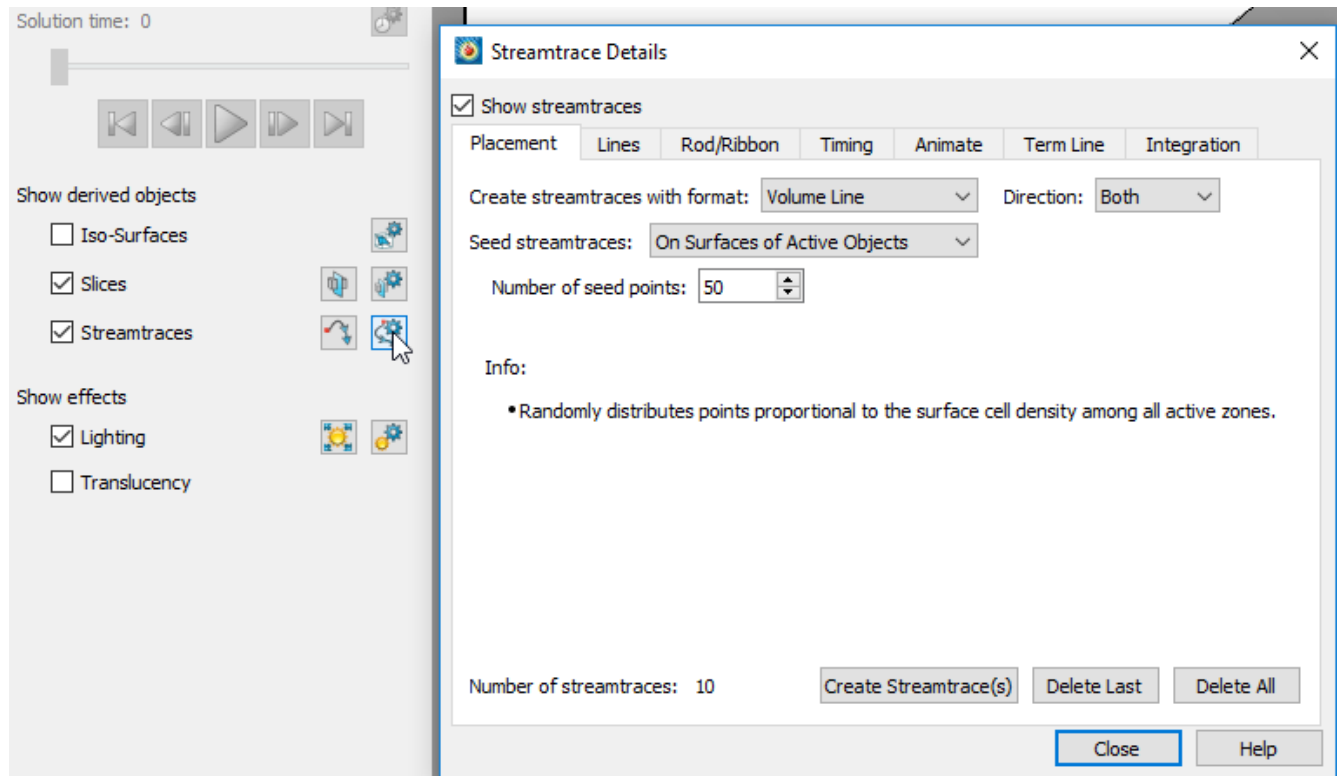

2. Click **Delete All** in the **Streamtrace Details** dialog to remove the existing streamtraces.
3. Change the drop-down menu at the top of the dialog to Volume Ribbon.
4. Click the streamtrace tool button next to Streamtraces in the Plot sidebar. Leave the Streamtrace Details open, but move it out of the way.
5. As before, drag out a line along the leading edge of the wing to seed the streamtraces and create the ribbons.

The plot should look something like this with the ribbons.

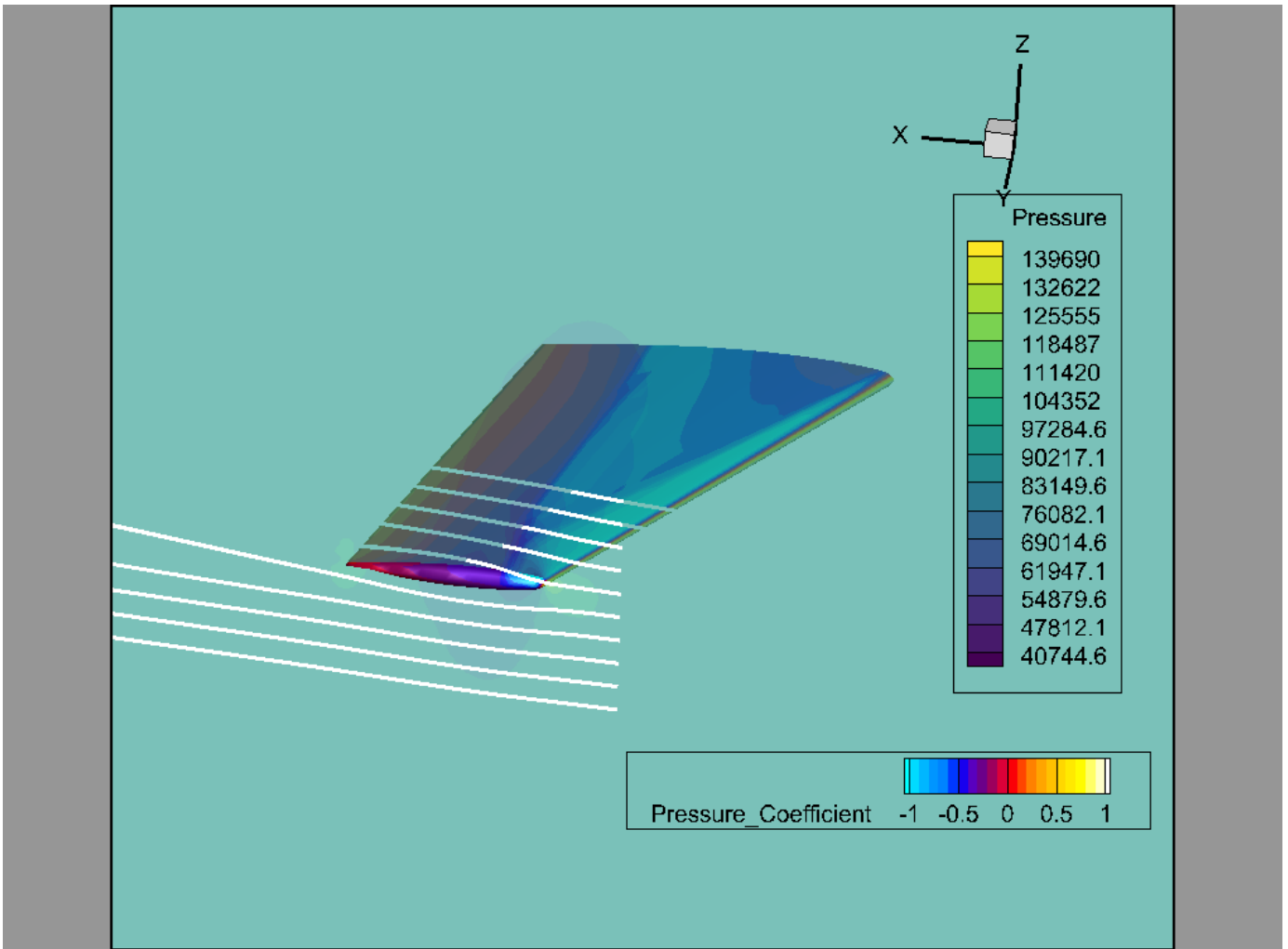

Let's change them from white to a more attention-grabbing color. We can do this on the Rod/Ribbon page of the **Streamtrace Details** dialog.

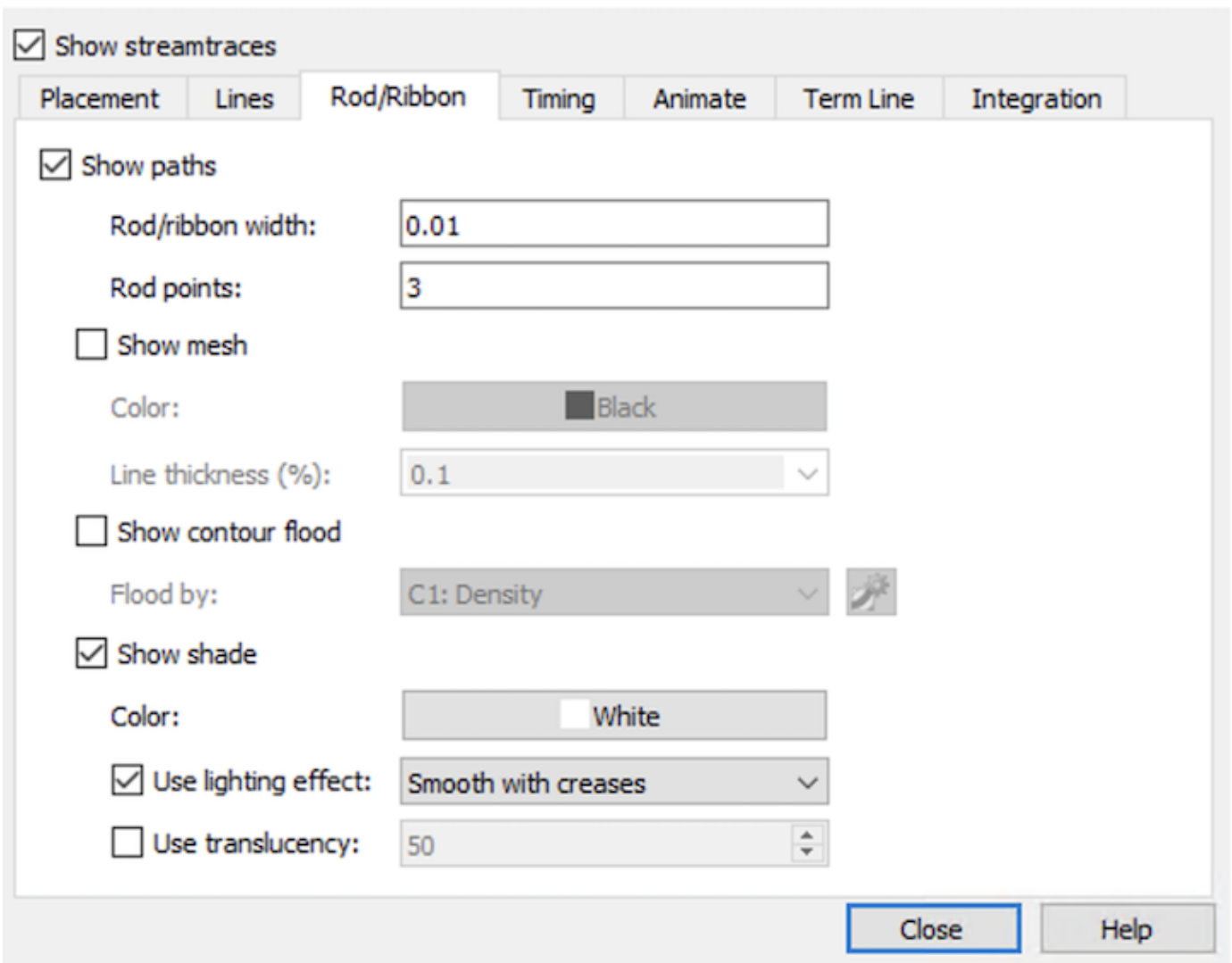

Near the bottom of this dialog, under the Show Shade checkbox, click the button next to Color. Then, in the Color Chooser, click the red swatch.

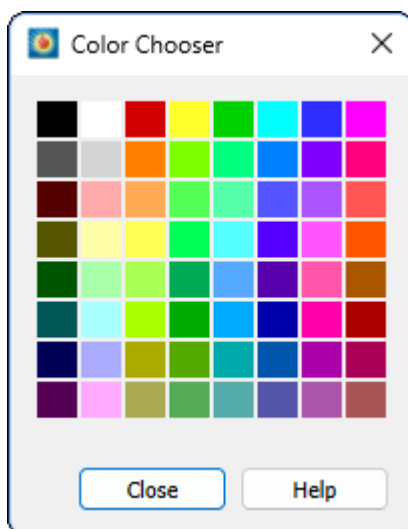

The plot with red ribbons is shown below:

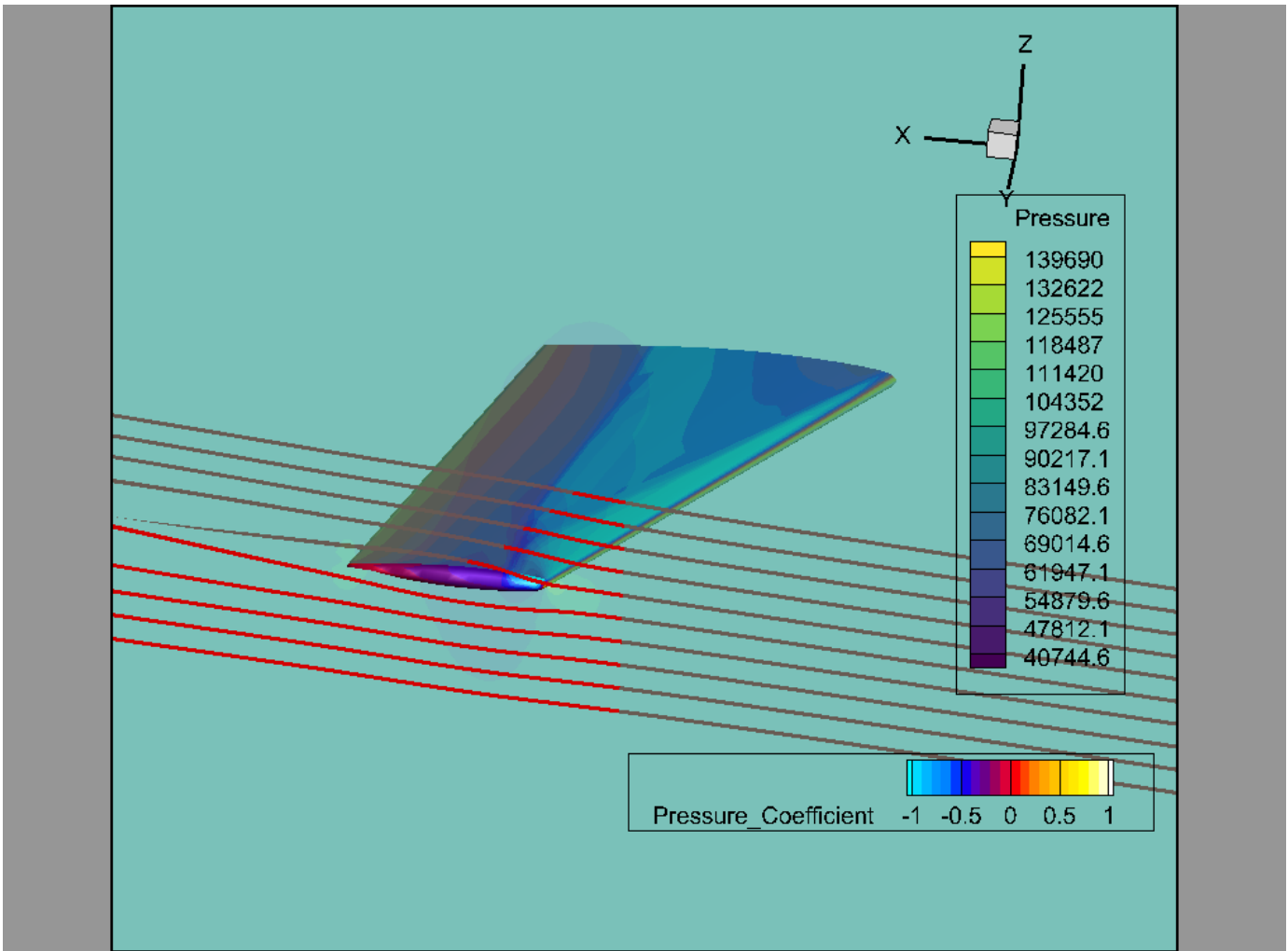

Step 7: Adjust Rotation and Lighting

You can adjust the direction of the lighting to make the ribbons stand out more. To do this, click the sun toolbar icon in the Plot sidebar.

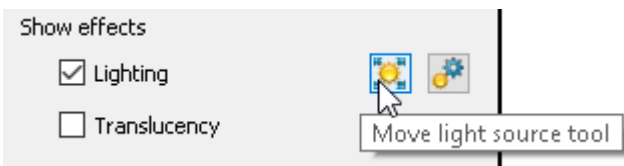

Click or drag around the plot to move the light. As you do so, you will find spots where the ribbons catch a highlight. You can also try rotating the plot to get the best view.

Step 8: Surface Streamtraces

So far, we've been looking at flow through the air around the wing: volume streamtraces and ribbons. We can also visualize the flow across the surface of the wing.

Just to be clear, these streamtraces will be calculated using the momentum data from the volume zone

around the wing. The wing surface zone does not actually contain momentum or velocity data. The data file we provide for this tutorial has the zones set up to make this work correctly.

We used the slice to specify a plane on which we could draw a line to seed streamtraces in a volume. When creating surface streamtraces, we just seed directly on the surface. So click the Slices checkbox in the Plot sidebar to turn off the slice.

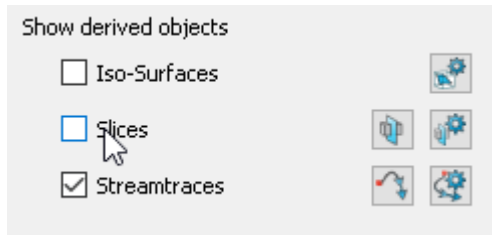

Next, let's delete the ribbons we've created by clicking **Delete All** on the Placement page of the **Streamtrace Details** dialog. Then choose "Surface Line" at the top of the dialog.

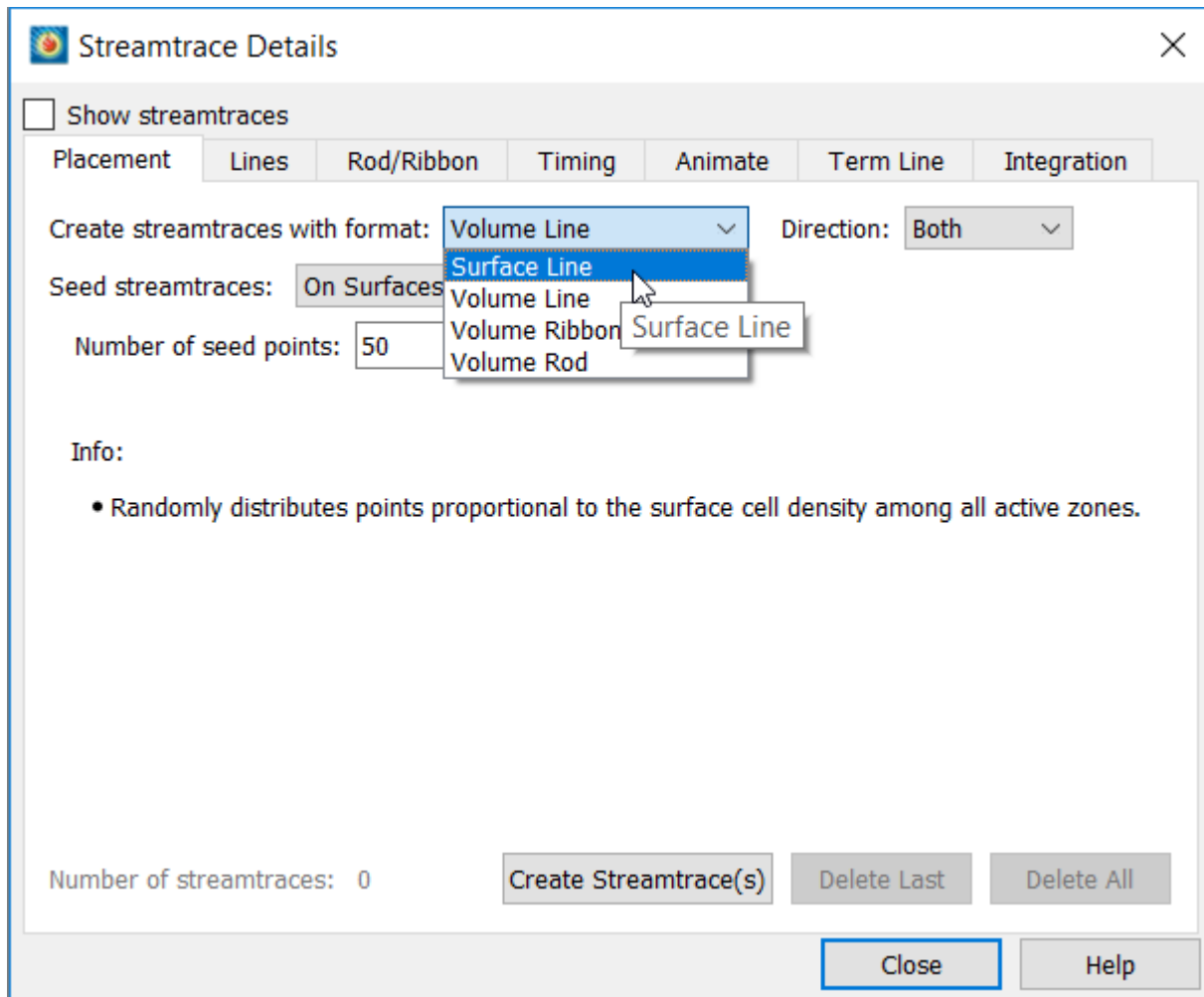

Let's rotate the wing again so that we can see across it. (Last reminder: hold Control, or Command on Mac, while dragging with the right mouse button.) We're going for an angle something like this.

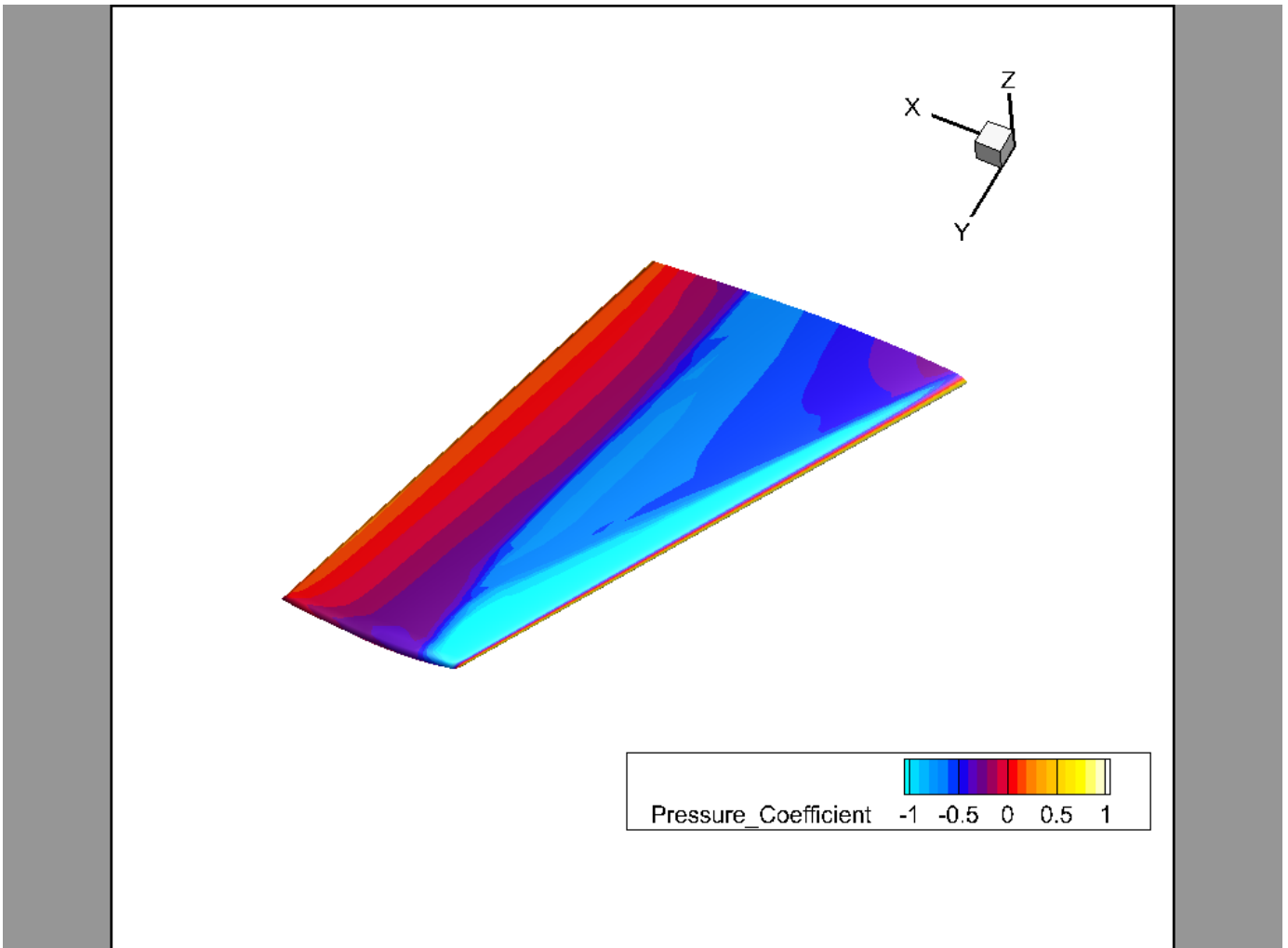

As always, you can use the orientation axis in the upper right corner of the plot to help you stay oriented.

Now, just as we did before when seeding from the surface of our slice, we choose the streamtrace tool in the Plot sidebar, then drag a line across the wing surface, parallel to the leading edge. After Tecplot 360 creates the streamtraces, we end up with something like this.

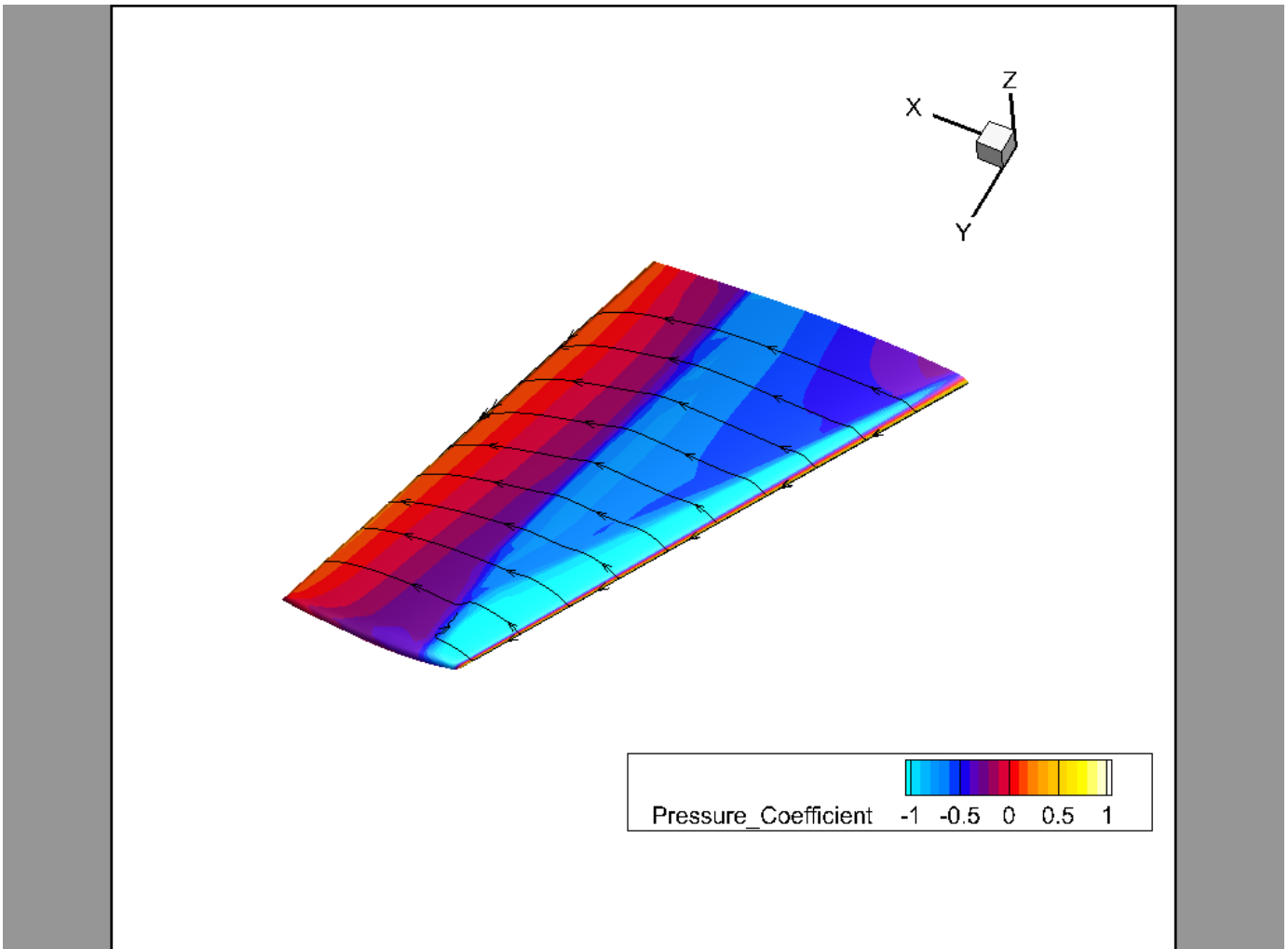

We made our streamlines thicker so you can see them more easily. For extra credit, figure out how to make yours thicker, too. (The setting you need is on the Lines page of the Streamtrace Details dialog.)

We're done with streamtraces for now. Turn off the Streamtraces checkbox in the Plot sidebar when you're done to hide the streamtraces and show just the wing.

Step 9: Create Iso-Surfaces

Iso-surfaces are a great way to visualize a constant value of a contour variable as a surface. In other words, you specify a value, and the iso-surface shows you where the specified variable has that value.

Let's use it to visualize the shockwave as the wing passes the speed of sound. We do this by creating an iso-surface at Mach 1.

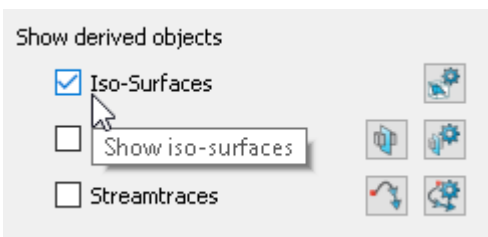

1. Turn on the Iso-Surfaces checkbox in the Plot sidebar.
2. Click the  button next to Iso-Surfaces to open the Iso-Surface Details dialog.

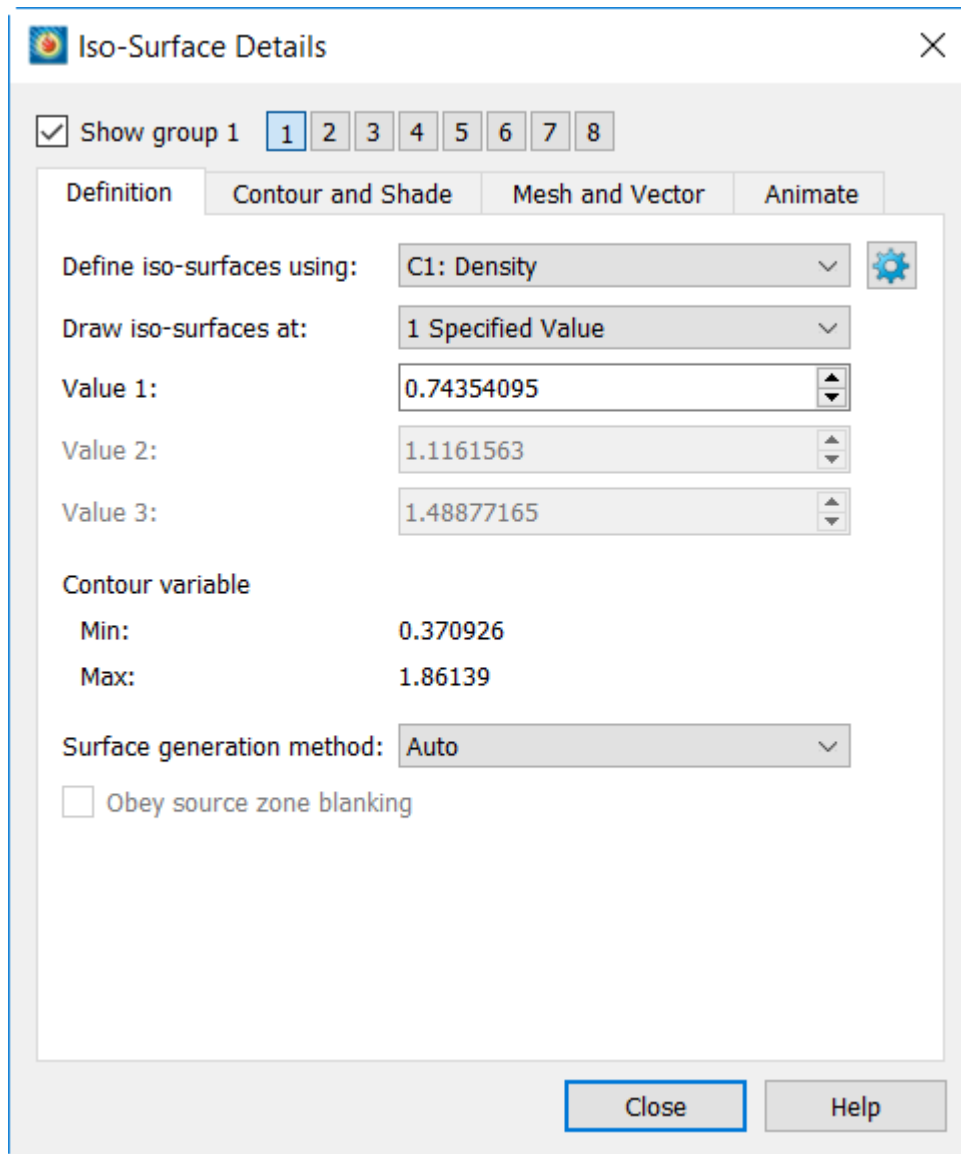

Now, we need to choose a contour group that associates the Mach variable with a color map. However, if you expand the Define Iso-Surfaces Using dropdown menu, you will see we don't have one. So we need to create one.

3. Click the gear icon next to this menu to open the Contour and Multi-Coloring Details dialog, which we've seen before.
4. Click the 3 button at the top of this dialog to define the third contour group.
5. Using the menu at the top of the dialog, choose the Mach variable.
6. Choose the Large Rainbow color map. Here's how it should look.

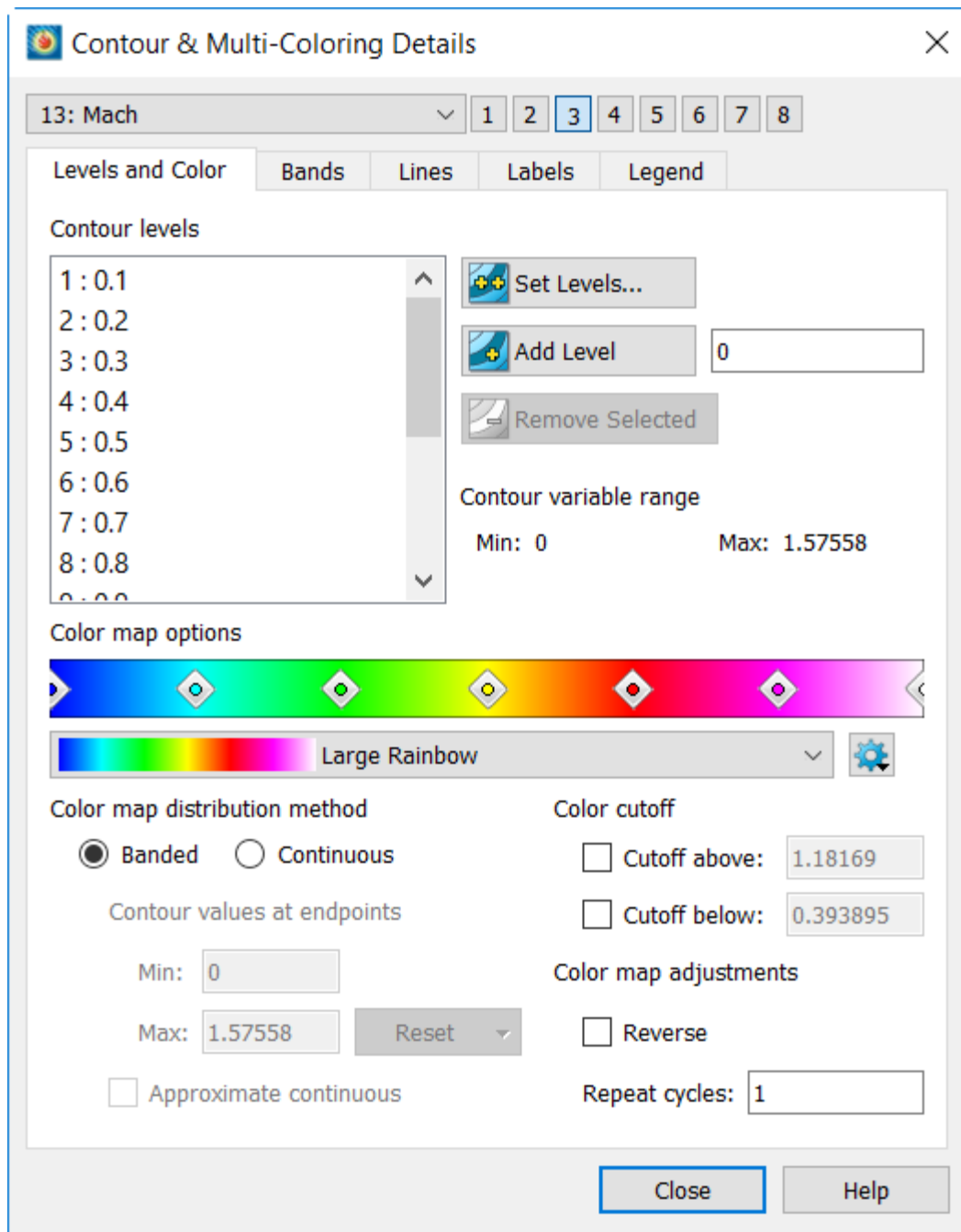

7. Close the **Contour and Multi-Coloring Details** dialog.
8. Back in the **Iso-Surface Details** dialog, choose contour group 3 from the *Define Iso-Surfaces Using* menu, then enter a value of 1 in the Value 1 field.

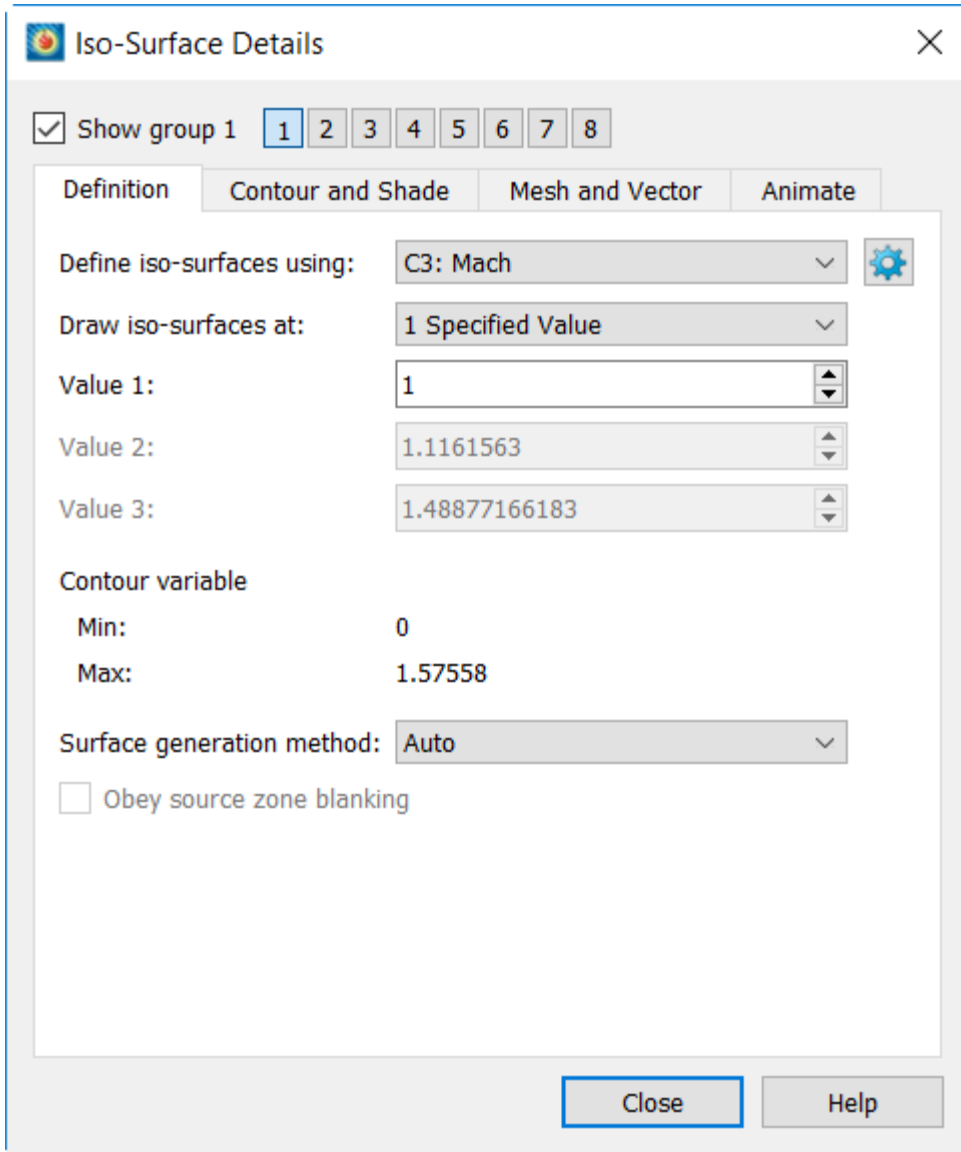

The plot is shown here. We've rotated the wing to get a better view.

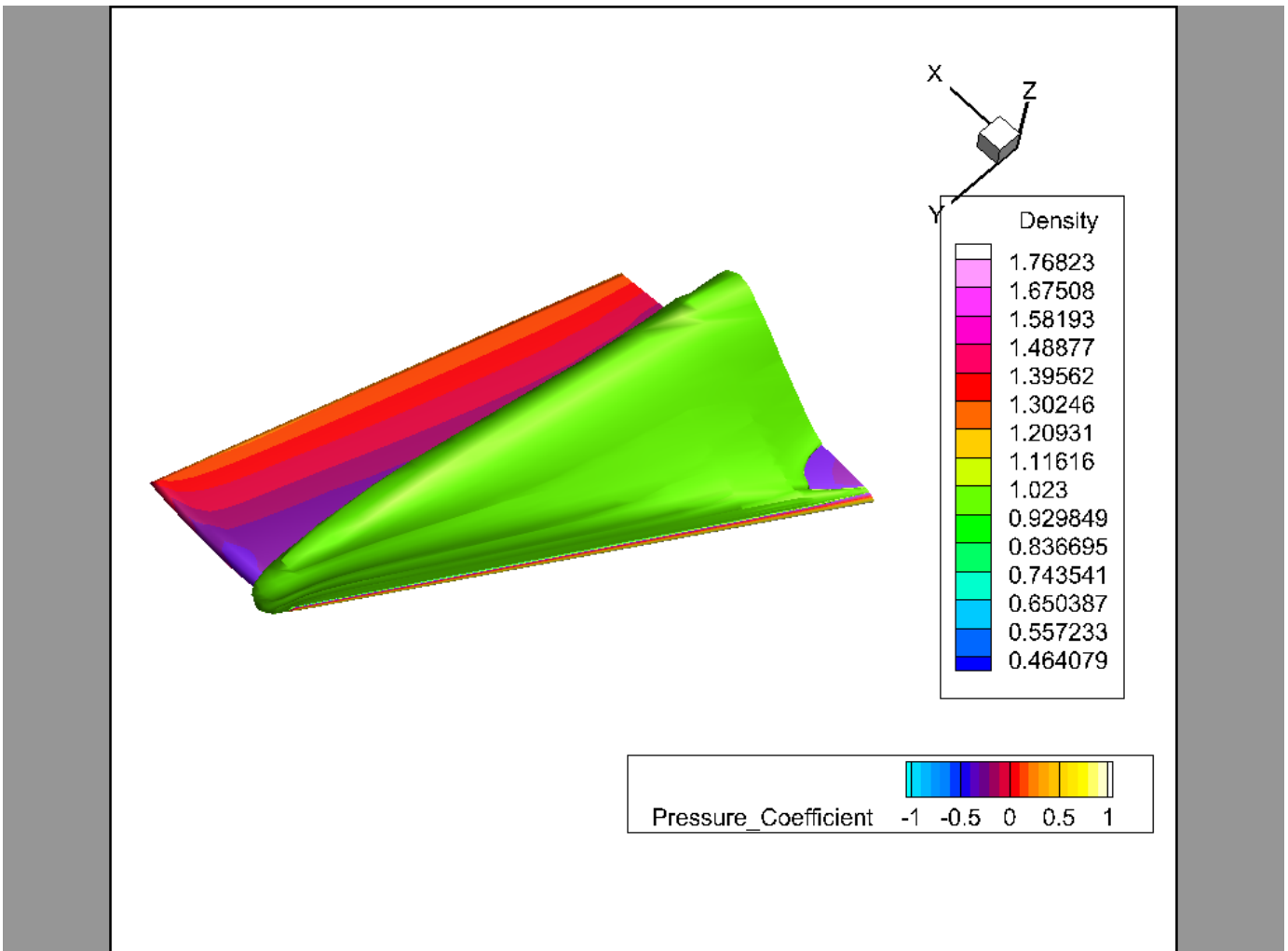

This iso-surface shows us where the air is moving at Mach 1 around the wing. Try adjusting the Value 1 field using the arrows next to the numeric entry field and watch the plot change in response.

It is often instructive to show more than one iso-surface at more than one value. Let's add a second iso-surface at Mach 1.2. To do this, change the **Draw Iso-Surfaces At** menu to *2 Specified Values* and enter 1.2 in the Value 2 field.

The dialog options are shown here.

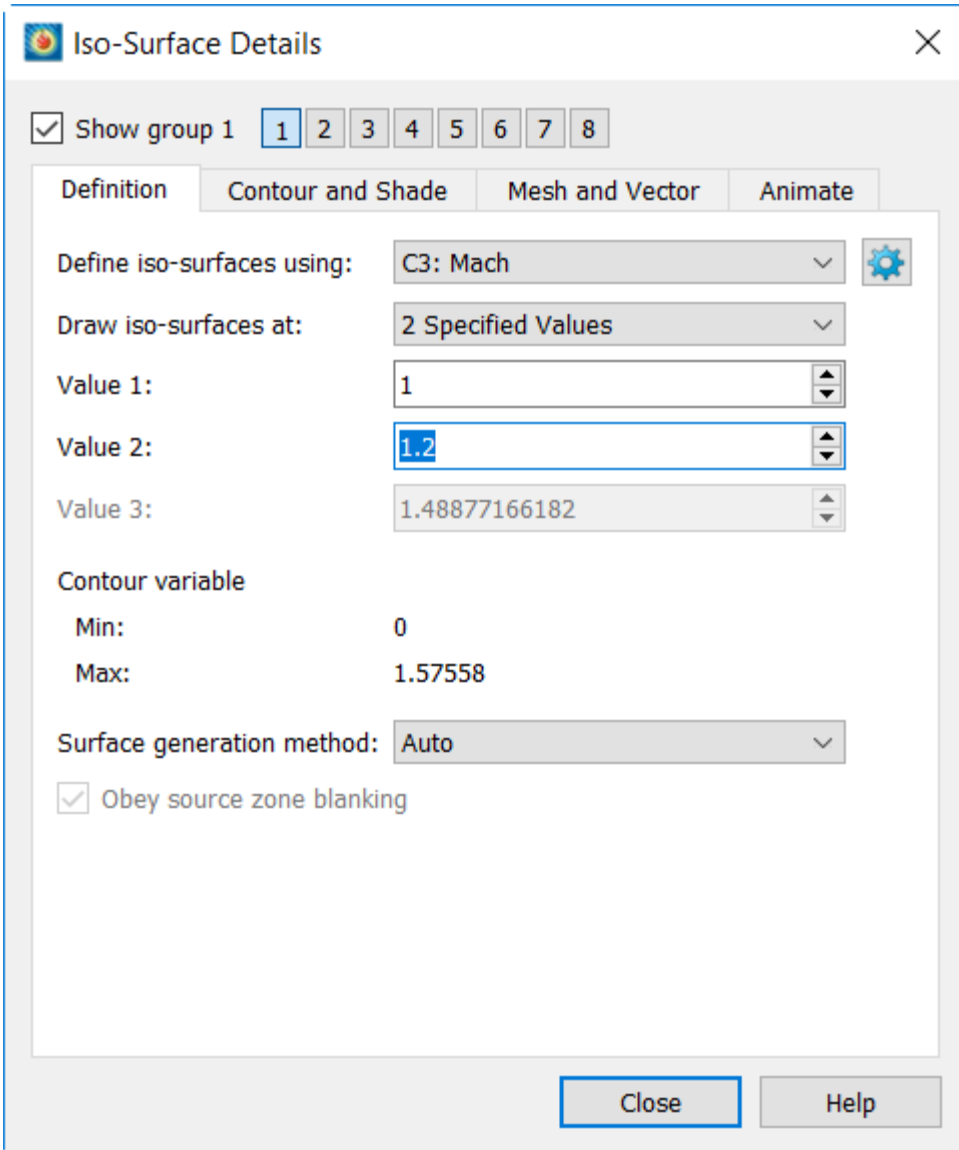

Where's the second iso-surface? Well, it's closer to the wing than the first one, so it is hidden. Let's make the iso-surfaces partly transparent so we can see the second one inside the first (and also, dimly, the wing surface inside the second).

To do this, right-click the iso-surface in the plot, then turn on transparency by clicking the rightmost icon in the toolbar. Our iso-surfaces are both in the same group, so they both become transparent.

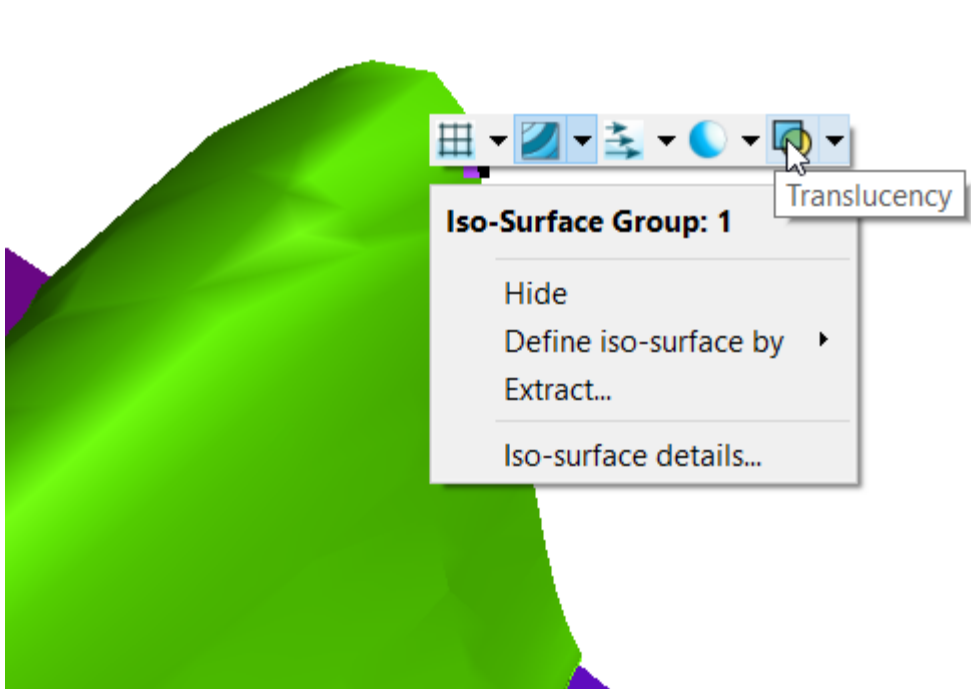

Now you can see the Mach 1.2 iso-surface inside the Mach 1 iso-surface. Rotate the plot and see! This is the shock surface where the transition between subsonic and supersonic is happening. Here's our final iso-surface plot.

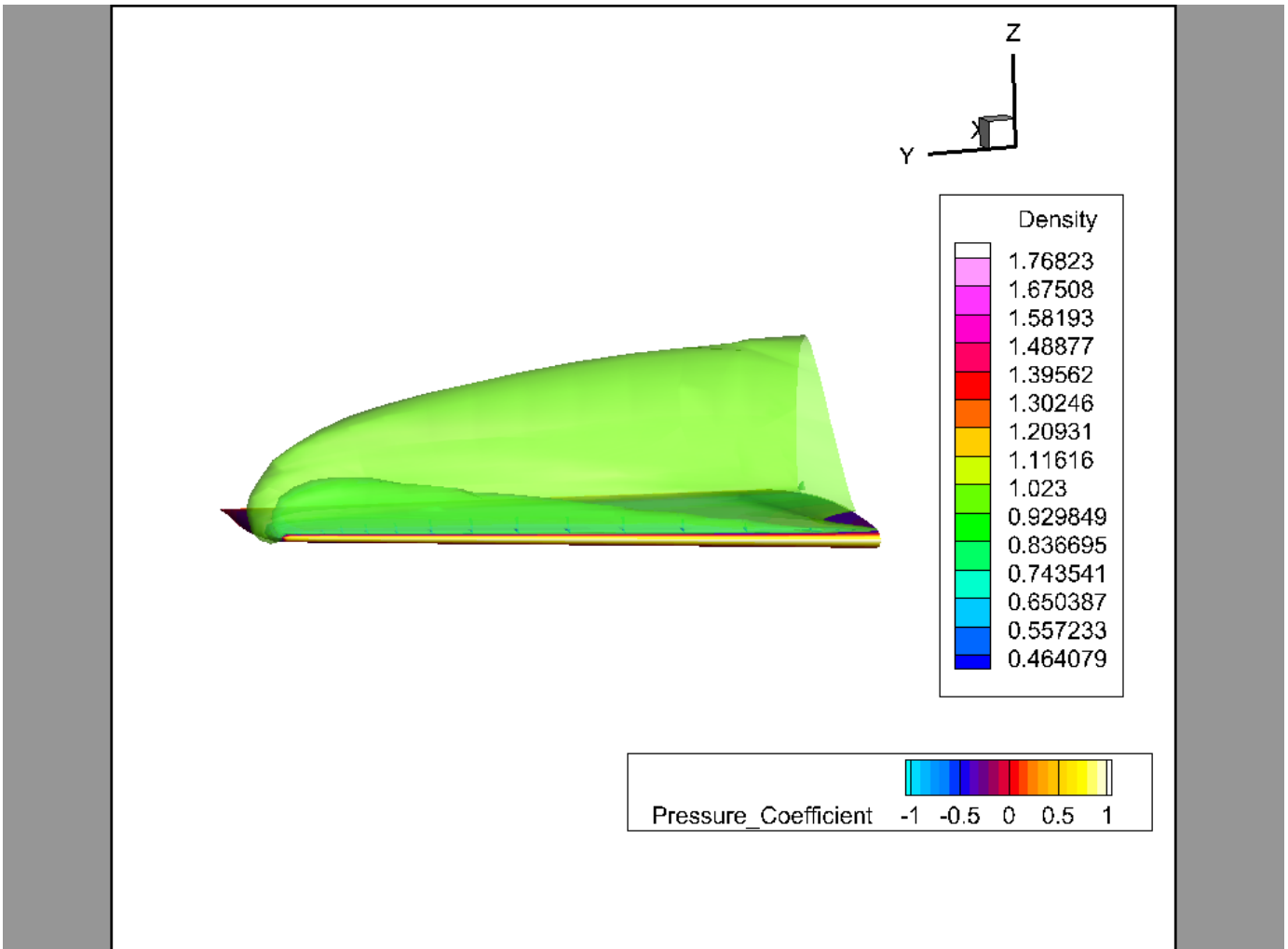

Step 10: Probe Data

The last exploration technique we'll explore is probing. Probing shows the values of all variables at a location you click in the plot. Simply choose the Probe tool from the toolbar at the top of the screen.



Now, click points of interest in your plot. The Probe sidebar, which pops out along the right edge of the screen, displays the variable values at each clicked location.

You can also copy variable names, values, or both from the probe results by selecting the desired information and right-clicking, or by pressing Control-C (Command-C on Mac OS X).

Variable	Value	
x	0.425983793755309592	Variable Values
y	0.338006084962933495	
z	0.31262965120760311	
Density	1.00150962451886727	Cell Center Values
Momentum U (Density*U)	331.637199230642238	
Momentum V (Density*V)	-9.69596885222857097	
Momentum W (Density*W)	14.8246646215857218	
Energy (Density*E)	N/A	Zone/Cell Info
SA Turbulent Eddy Viscosity	N/A	
Pressure	N/A	
Temperature	N/A	
Pressure_Coefficient	N/A	Face Neighbor
Mach	1	
Laminar_Viscosity	N/A	
Skin_Friction_Coefficient	N/A	
Heat_Flux	N/A	
Y_Plus	N/A	
Eddy_Viscosity	N/A	

As with any sidebar, you can move the Probe sidebar to another edge of the workspace, combine it with another sidebar, or even tear it off and move it outside the main Tecplot 360 window—to a different monitor, if you want.

As before, a Tecplot 360 layout (.lay) file containing a snapshot of the final result of this tutorial segment is in `OneraM6wing/finallayouts/ExtenalFlowVideo2.lay` in the `examples` folder in your Tecplot 360 installation folder.

Comparing a CFD Simulation with Experimental Data

In this segment, we'll be creating a classic Coefficient of Pressure (C_p) plot using both simulated and experimental data. To do this, we'll first append the experimental data, which was gathered via pressure taps along the wing in a wind tunnel. Then we'll extract a slice and create an XY line plot in a new frame.

The experimental data is normalized in both the span and chord directions: the Y direction is normalized by b (the span) and the X direction is normalized by c (the chord). The simulation data is not normalized, so part of our work will be to adapt the experimental data so that it can be compared to the simulation.

Step 1: Load Layout

We'll be continuing from where we left off with segment 1 of this tutorial, *not* from segment 2. Load the layout `OneraM6wing/finallayouts/ExtenalFlowVideo1.lay` in the `examples` folder in your Tecplot 360 installation folder and follow along.

Step 2: Append Experimental Data

Choose **File** → **Load Data** from the Tecplot 360 menu, then open the experimental data file. This is a

Tecplot ASCII file named `Onera_Experimental.dat` and can be found `OneraM6wing` folder in your Tecplot 360 `examples` directory. (If you can't see this file, choose All Files in the menu at the bottom of the dialog.) The experimental data file we've included is a slightly modified version of data provided by NASA. For more information, see turbmodels.larc.nasa.gov/onerawingnumerics_val.html.

If you used All Files, the **Choose Loader** dialog appears after you select the file to ask what format the data is in.

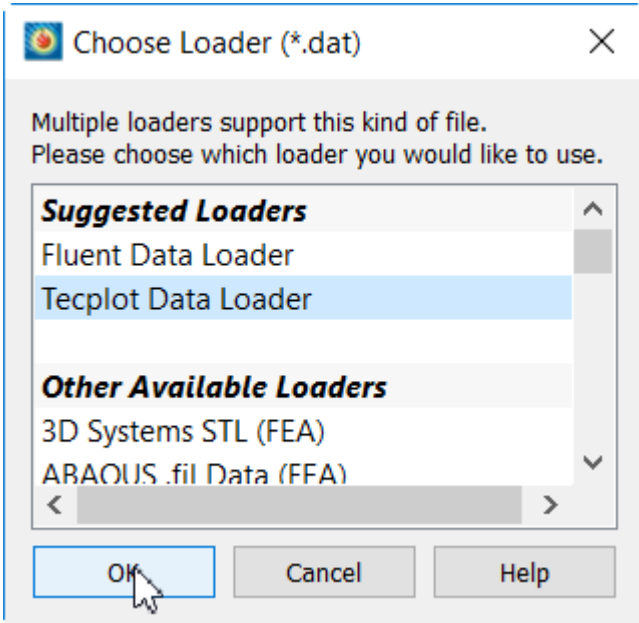

Choose **Tecplot Data Loader** and click **OK**.

Next, Tecplot 360 asks whether you want the new data to replace the existing data, or to append the new data.

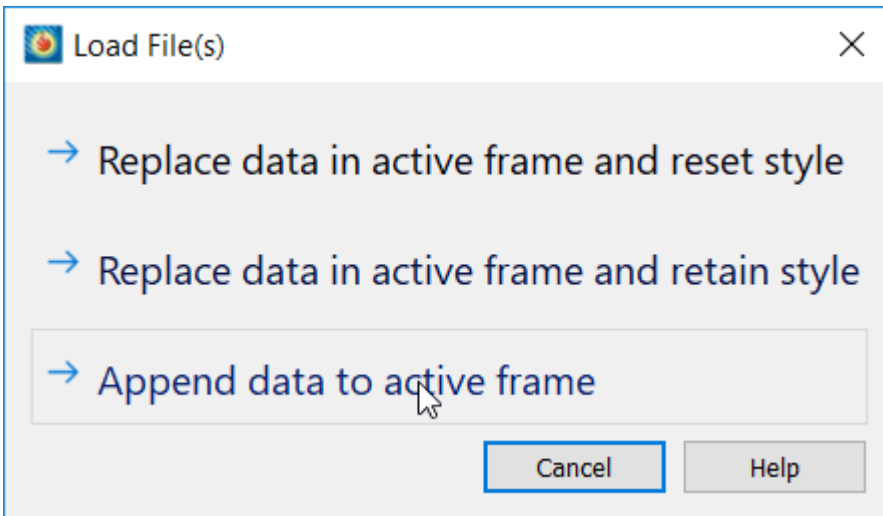

In the Load File(s) dialog, click **Append data to active frame**.

Step 3: Variable Load and Combine

The **Variable Load and Combine** dialog should appear after appending the data. This dialog gives the user options to combine certain variables as well as the option to not add certain variables. Variables that are automatically combined are colored blue. Manually combined variables are colored green. Anything else is colored black. Notice that Pressure_Coefficient has been automatically combined.

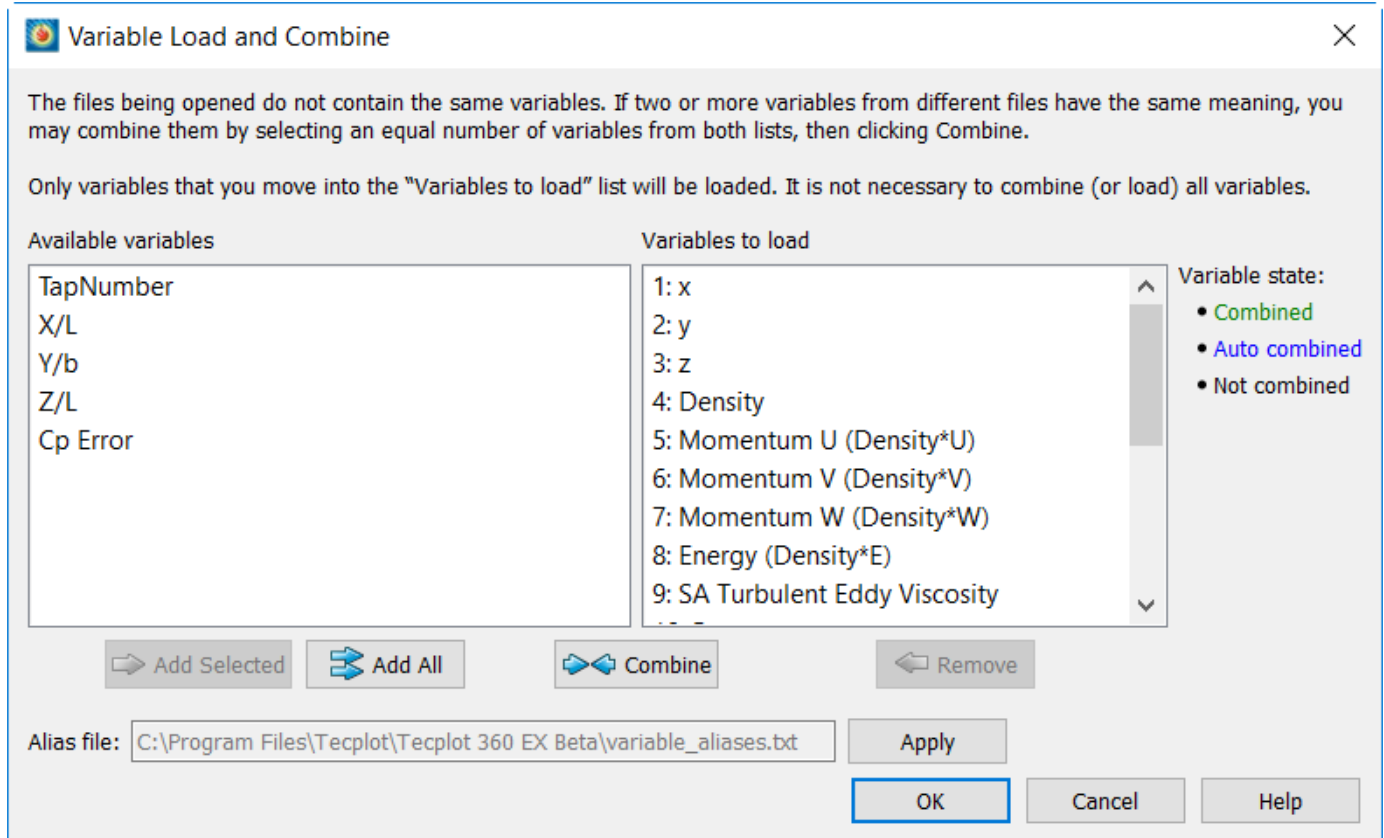

For this example, we will load all of the variables from the Experimental dataset. Select **Add All** and then select **OK** to close the **Variable Load and Combine** dialog.

To verify that the data was loaded correctly, open the **Data Set Information** dialog by choosing **Data** → **Data Set Info** from the menu. Notice the seven new zones: **Section 1 - 0.2**, **Section 2 -0.44**, and so on. These zones contain the experimental data from the pressure taps placed along the wing.

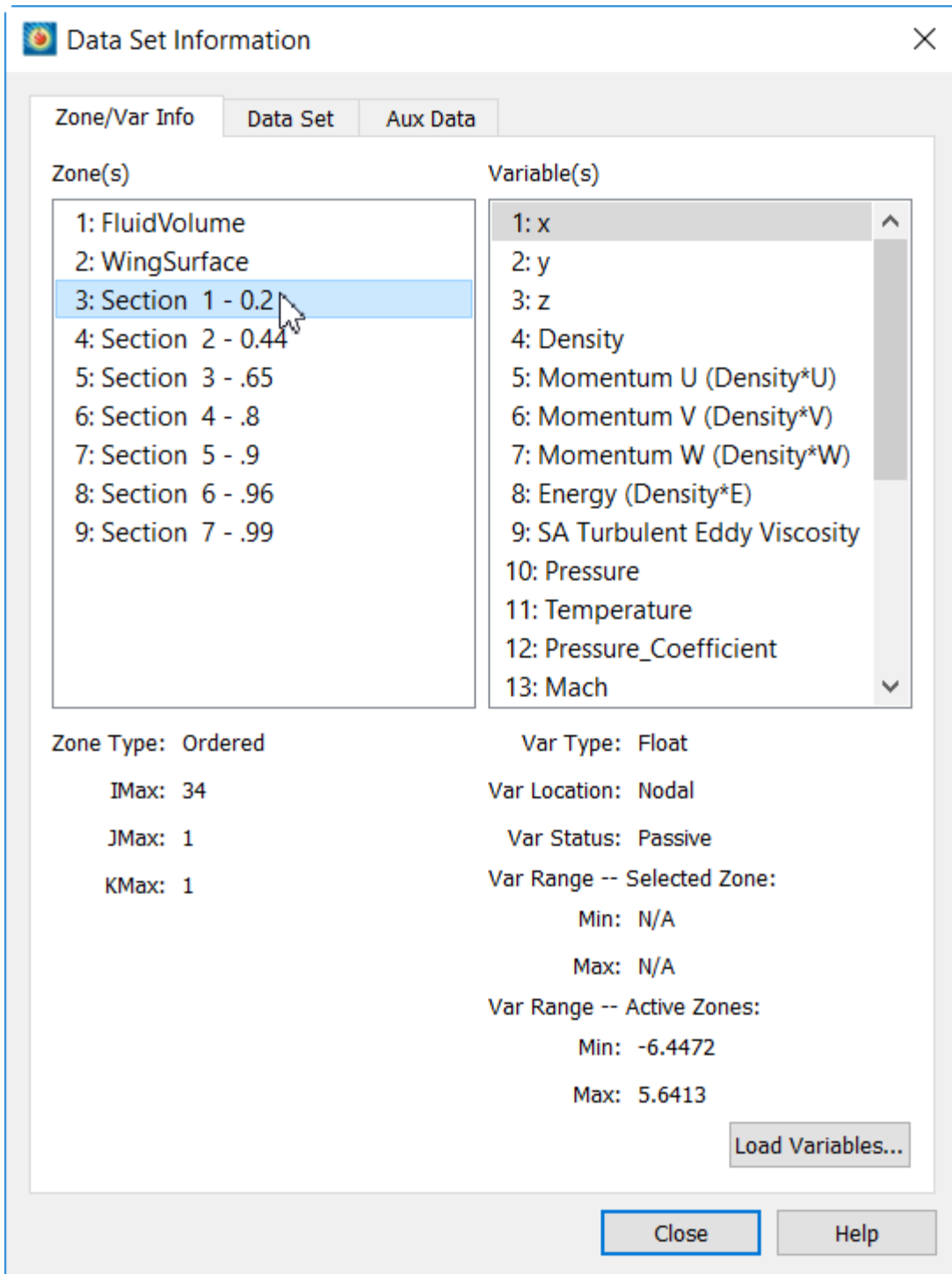

You'll also notice several new variables, starting at variable #19: TapNumber, X/L, Y/b, Z/L, and Cp Error.

Step 4: Normalize Y to Y/b

We want to compare the experimental data with our simulation data at a pressure tap location. However, the experimental data is, as we mentioned, normalized: instead of using a Y that ranges from 0 to the span length, as in the simulation data, it uses a Y over b (Y/b) that ranges from 0 to 1.

If we open the **Data Spreadsheet** dialog (**Data** → **Spreadsheet**), choose our WingSurface zone, and

scroll over to see the "Y/b" variable, we can see that our simulation data does not contain this information. It is only in the experimental data set.

The screenshot shows a 'Data Spreadsheet' window with the following settings: Zone: 2: WingSurface, Variable: 1: x, Plane: K, Index: 1, Format: Best Float, Precision: 3. The spreadsheet contains 20 rows of data. The columns are: N \ V, efficie, Heat_Flux, Y_Plus, Eddy_Viscosity, TapNumber, X/L, Y/b, Z/L, and Cp Error. The 'Y/b' column is highlighted in blue and contains the value '0' for every row from 1 to 20. The 'Heat_Flux', 'Y_Plus', and 'Eddy_Viscosity' columns contain 'Not Loa...' or 'Not Loaded'. The 'TapNumber', 'X/L', 'Z/L', and 'Cp Error' columns contain '0'. At the bottom of the window, there is a checkbox for 'Alter in all shared zones', a 'Load Variables...' button, and 'Close' and 'Help' buttons.

N \ V	efficie	Heat_Flux	Y_Plus	Eddy_Viscosity	TapNumber	X/L	Y/b	Z/L	Cp Error
1		Not Loa...	Not Loa...	Not Loaded	0	0	0	0	0
2		Not Loa...	Not Loa...	Not Loaded	0	0	0	0	0
3		Not Loa...	Not Loa...	Not Loaded	0	0	0	0	0
4		Not Loa...	Not Loa...	Not Loaded	0	0	0	0	0
5		Not Loa...	Not Loa...	Not Loaded	0	0	0	0	0
6		Not Loa...	Not Loa...	Not Loaded	0	0	0	0	0
7		Not Loa...	Not Loa...	Not Loaded	0	0	0	0	0
8		Not Loa...	Not Loa...	Not Loaded	0	0	0	0	0
9		Not Loa...	Not Loa...	Not Loaded	0	0	0	0	0
10		Not Loa...	Not Loa...	Not Loaded	0	0	0	0	0
11		Not Loa...	Not Loa...	Not Loaded	0	0	0	0	0
12		Not Loa...	Not Loa...	Not Loaded	0	0	0	0	0
13		Not Loa...	Not Loa...	Not Loaded	0	0	0	0	0
14		Not Loa...	Not Loa...	Not Loaded	0	0	0	0	0
15		Not Loa...	Not Loa...	Not Loaded	0	0	0	0	0
16		Not Loa...	Not Loa...	Not Loaded	0	0	0	0	0
17		Not Loa...	Not Loa...	Not Loaded	0	0	0	0	0
18		Not Loa...	Not Loa...	Not Loaded	0	0	0	0	0
19		Not Loa...	Not Loa...	Not Loaded	0	0	0	0	0
20		Not Loa...	Not Loa...	Not Loaded	0	0	0	0	0

However, if you use the Zone menu to switch to one of the experimental data zones, such as [Section 1 - 0.2](#), you will see that it has values for this variable.

Data Spreadsheet

Zone: 3: Section 1 - 0.2 Variable: 1: x

Plane: K Index: 1 Format: Best Float Precision: 3

I \ V	efficie	Heat_Flux	Y_Plus	Eddy_Viscosity	TapNumber	X/L	Y/b	Z/L	Cp Error
1		0	0	0	12	0.9503	0.2	-0.00726	0.02
2		0	0	0	11	0.81597	0.2	-0.02193	0.02
3		0	0	0	10	0.66593	0.2	-0.03587	0.02
4		0	0	0	9	0.56588	0.2	-0.04301	0.02
5		0	0	0	8	0.46599	0.2	-0.04773	0.02
6		0	0	0	7	0.3658	0.2	-0.04889	0.02
7		0	0	0	6	0.26579	0.2	-0.04702	0.02
8		0	0	0	5	0.16594	0.2	-0.04194	0.02
9		0	0	0	4	0.04993	0.2	-0.02971	0.02
10		0	0	0	3	0.02002	0.2	-0.02268	0.02
11		0	0	0	2	0.00593	0.2	-0.01333	0.02
12		0	0	0	1	0.00034	0.2	0.00292	0.02
13		0	0	0	34	0.00216	0.2	0.00802	0.02
14		0	0	0	33	0.00866	0.2	0.01592	0.02
15		0	0	0	32	0.02037	0.2	0.02285	0.02
16		0	0	0	31	0.03525	0.2	0.02701	0.02
17		0	0	0	30	0.06036	0.2	0.0313	0.02
18		0	0	0	29	0.09959	0.2	0.03617	0.02
19		0	0	0	28	0.15037	0.2	0.0408	0.02
20		0	0	0	27	0.20044	0.2	0.04413	0.02

Alter in all shared zones

Load Variables... Close Help

Therefore, we will need to calculate this variable for our simulation data. We can do this using an equation.

Close the **Data Spreadsheet** dialog, then open the **Specify Equations** dialog by choosing **Data** → **Alter** → **Specify Equations**. We know that the span of the wing, b , is 1.19 from publicly-available information about the Onera M6 model. So, in the Equation(s) field, enter:

$$\{Y/b\} = \{y\}/1.19$$

We only want to calculate this variable in our simulation zones, since it already exists in our experimental zones, so make sure only FluidVolume and WingSurface are selected in the Zones to Alter list. (Hold down the Control key, or Command on Mac, while clicking zones to toggle them on and off.) The **Specify Equations** dialog should appear as shown below.

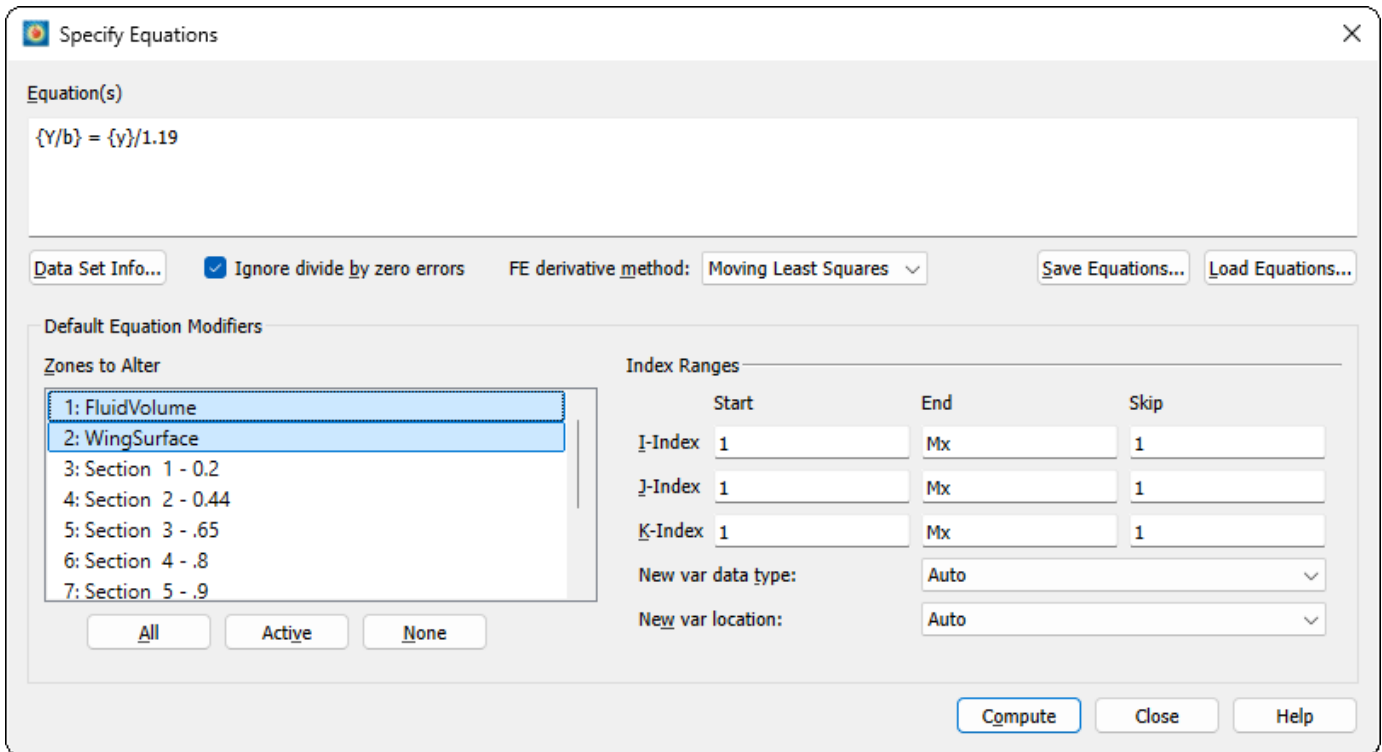

Click **Compute** to calculate the Y/b value for our simulation zones.

Finally, let's check our work by probing at the wing tip.

1. Click the Probe tool in the Tecplot 360 toolbar.
2. Click at the tip of the wing.
3. Observe the Y/b value in the Probe sidebar.

We should expect a value of 1 for Y/b . However, since the wing tip is beveled, the Y/b value will actually be slightly greater than 1. Everything is exactly as it should be. Mission accomplished!

Step 5: Extract Slice from Simulation Data at Pressure Tap Location

Let's go ahead and change the Y axis to Y/b . Choose **Plot** → **Assign XYZ** from the Tecplot 360 menu bar. Then, in the Select Variables dialog, choose "Y/b" for the Y-axis variable, as shown here. Click **OK**. to save this change.

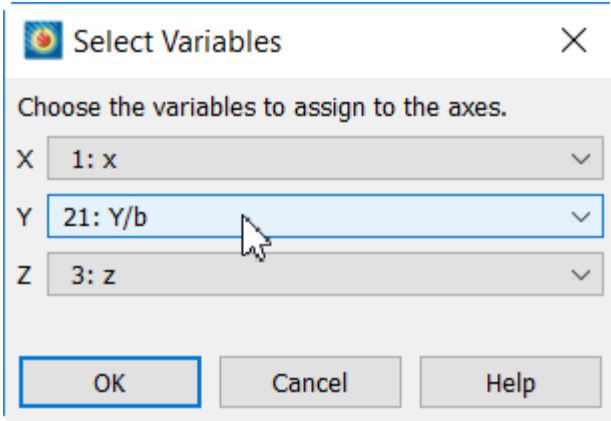

The wing may rotate in the workspace when you change the Y variable. This is normal.

Our experimental data contains information only at the locations of the pressure taps on the wing. For this example, we'll compare the simulation data with the experimental data from the pressure tap at $Y/b = 0.65$. We will create a slice of the simulation at this location and extract that slice to a new zone.

All the simulated surface data along the wing at the location of the pressure tap, in other words, will be copied into a new two-dimensional zone. Here's how.

1. Turn on slices in the Plot sidebar.

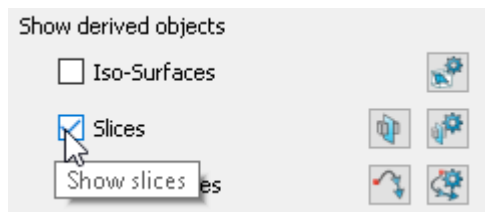

2. Open the Slice Details dialog by clicking next to Slices in the Plot sidebar.
3. In the **Slice Details** dialog:
 - Change the Slice Location to Y-Planes
 - Make sure Show Primary Slice is enabled
 - Enter the value 0.65 for the location of the primary slice.
 - Set Slice Through to Surface Zones.

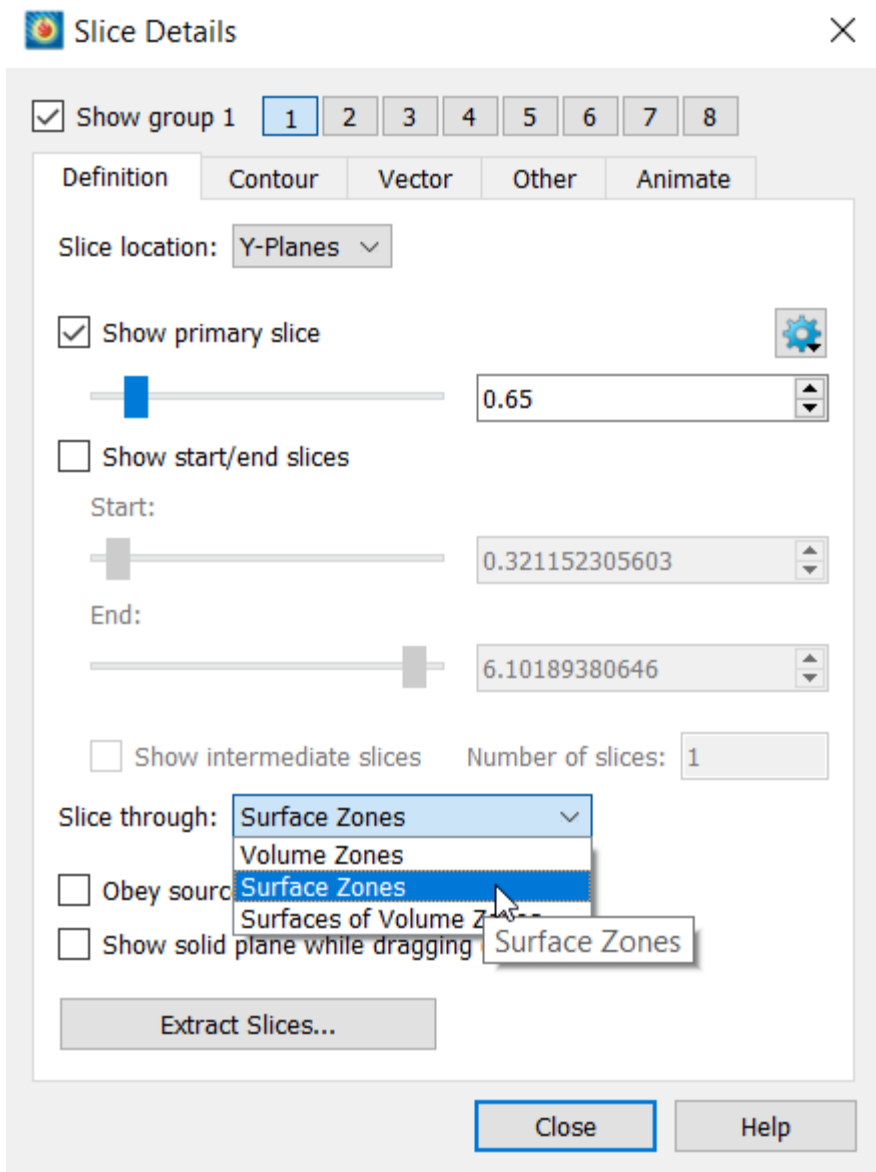

A band appears on the surface of the wing at the location of our slice, as shown below.

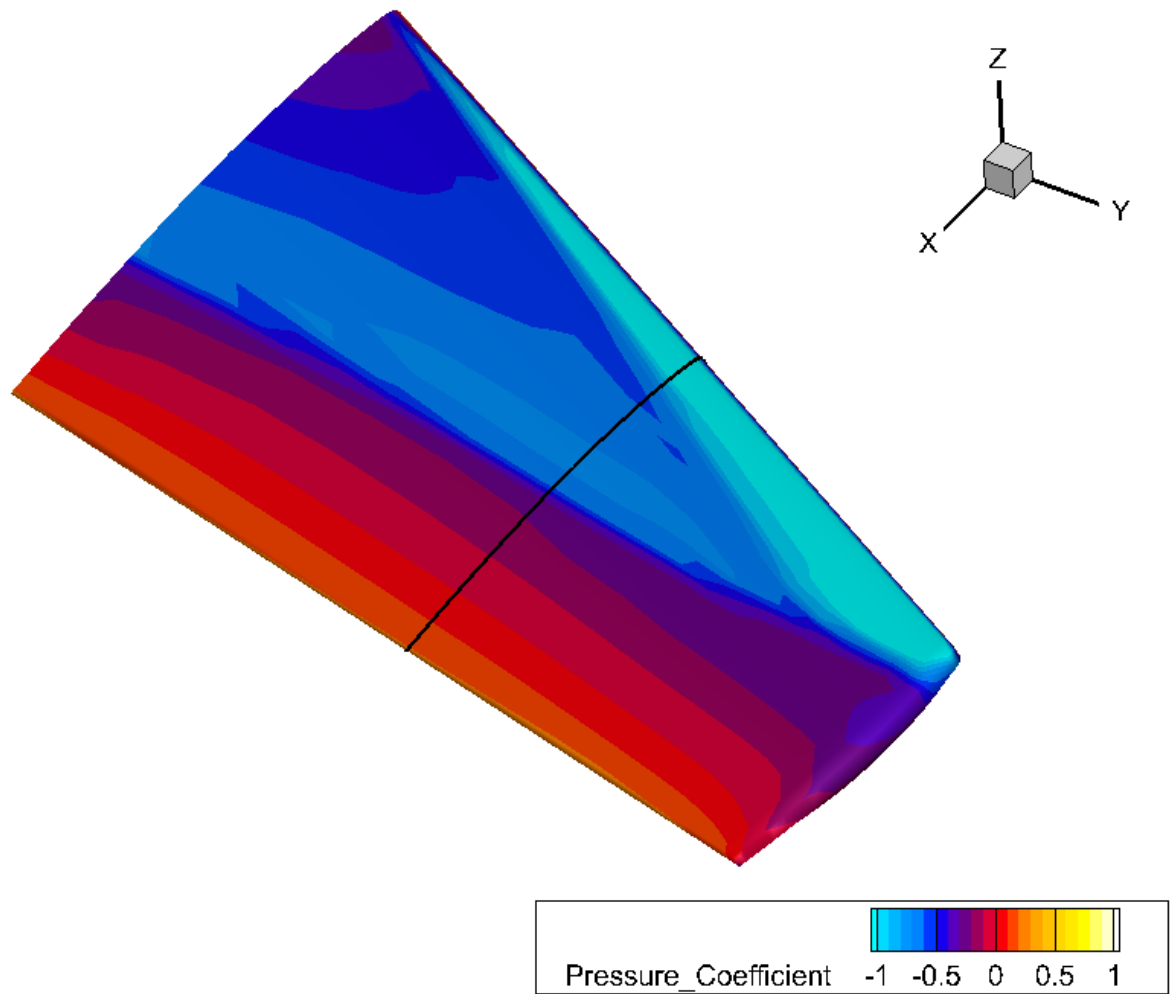

4. Choose the **Extract Slices** button to extract this slice to a new zone. (Or by selecting **Data → Extract → Slices**).

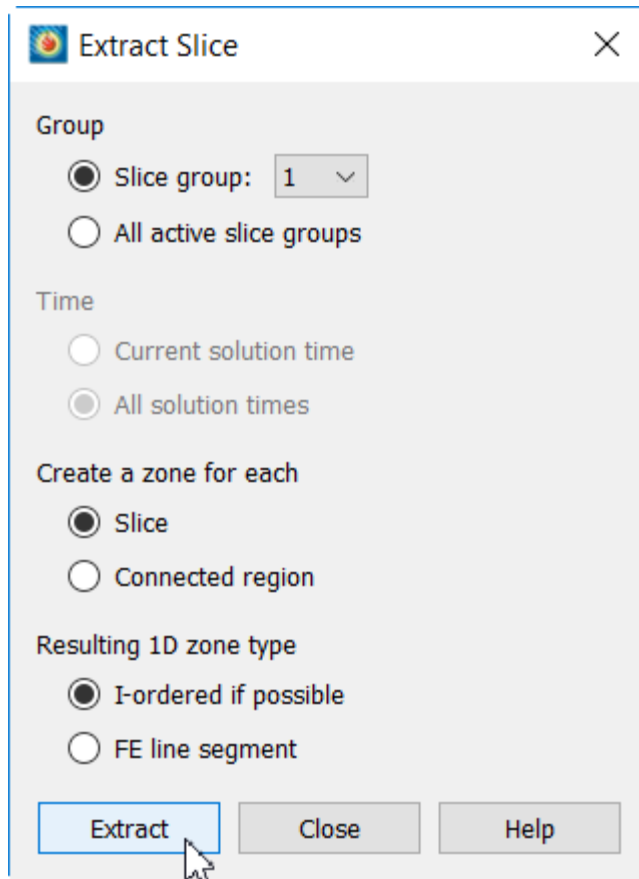

5. In the **Extract Slice** dialog, leave all of the default values and click **Extract** to proceed with the slice extraction.
6. Close the **Extract Slice** dialog and the **Slice Details** dialog.

Our new slice zone is zone 10 and is named "Slice Y=0.65." You can verify this in Data Set Information, if you like.

Step 6: Normalize Slice's X to X/L

Now we can normalize the X dimension of our slice to the chord, in order to match the experimental data. We'll do this using the same **Specify Equations** dialog we used to normalize the Y dimension. In the experimental data, this is stored as the variable X/L . (If you're curious, you can verify this in the **Data Spreadsheet** dialog, as we did previously with Y/b .)

The equation we'll need is:

$$\{X/L\} = (\{x\} - \text{MINX}) / (\text{MAXX} - \text{MINX})$$

There's a twist that we need to address before we actually perform this calculation. The equation uses the **MAXX** and **MINX** intrinsic variables. These variables are provided by Tecplot 360 and refer to the maximum and minimum values of X in *all active zones*. We want the maximum and minimum X for just our slice, so as to calculate the chord, so we need to temporarily deactivate all other zones while

we perform this calculation.

So open the **Zone Style** dialog by clicking the **Zone Style** button in the Plot sidebar.

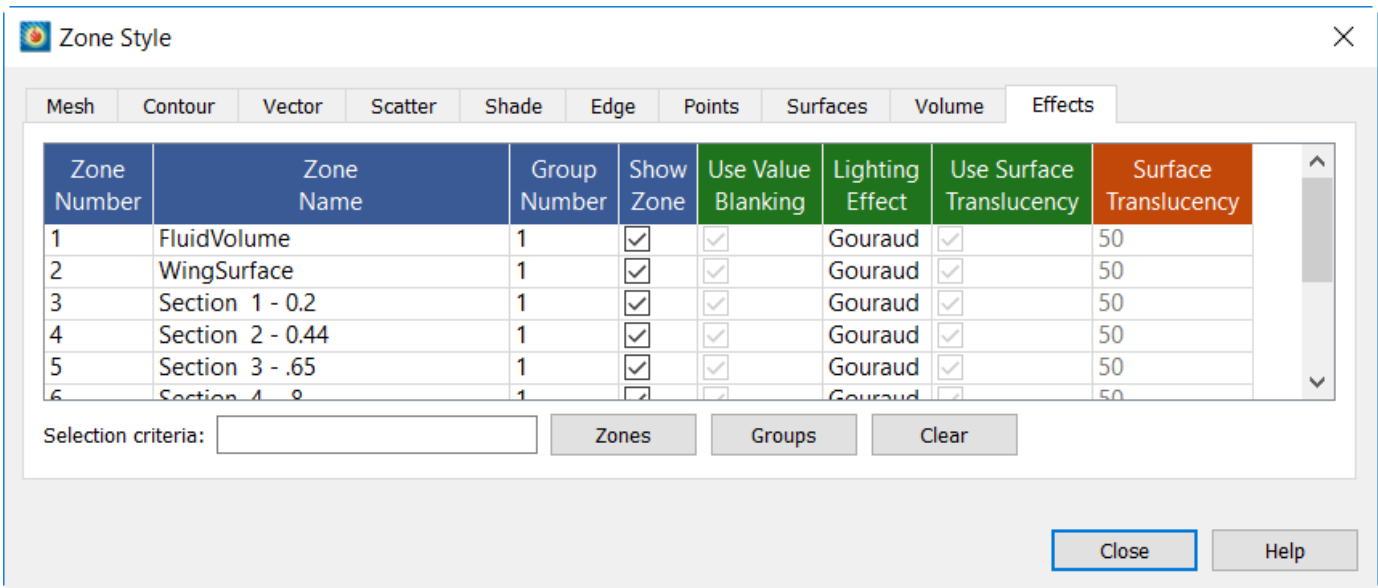

Right-click the Show Zone checkbox for the extracted slice zone and choose Show Selected Only.

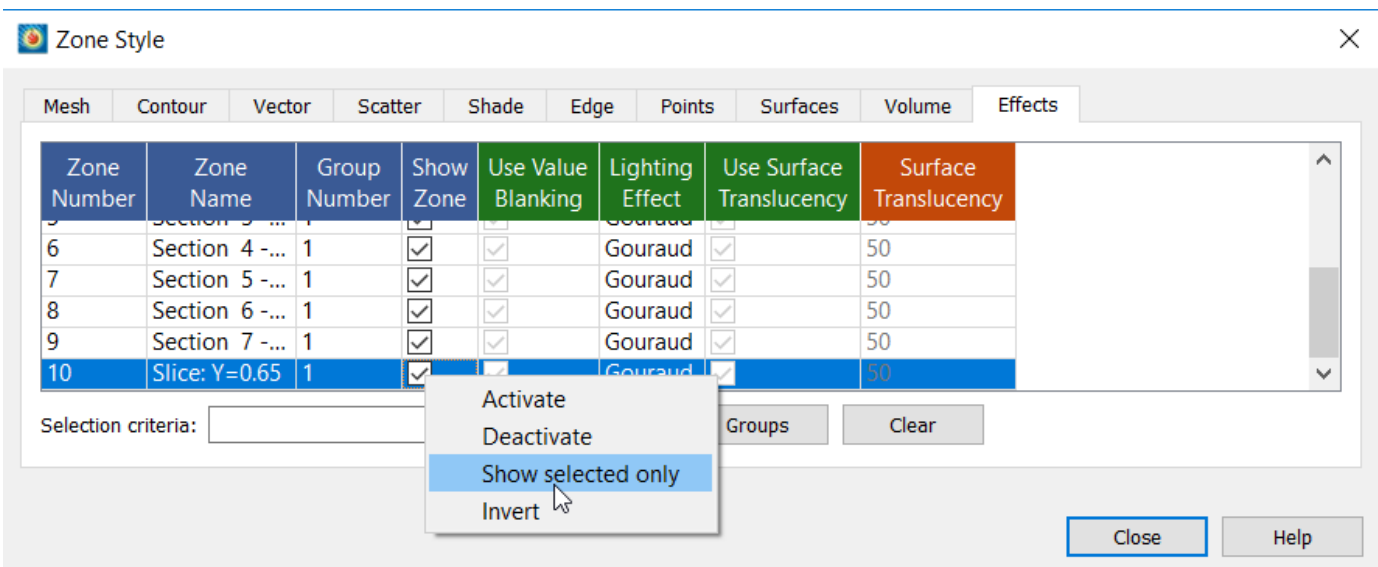

The checkboxes next to all zones except the slice zone toggle off. Your plot also disappears; don't panic!

Now, choose **Data** → **Alter** → **Specify Equations** and enter our equation in the Equation(s) field. For convenience, here it is again:

$$\{X/L\} = (\{x\} - \text{MINX}) / (\text{MAXX} - \text{MINX})$$

Since we need this calculation only for the slice, make sure our new slice zone, listed at the bottom of the Zones To Alter list as "10: Slice Y=0.65" is the only zone selected.

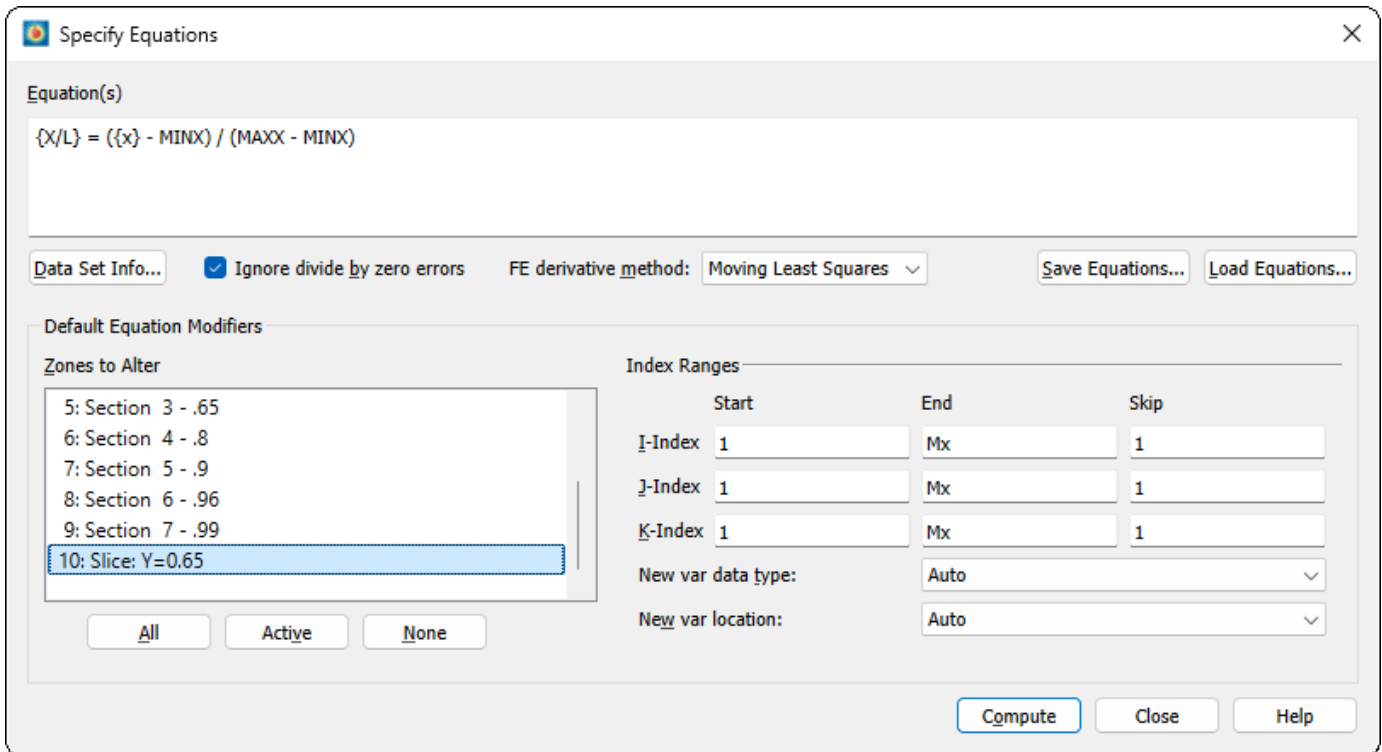

Now you're ready to click **Compute**.

After the calculation is complete, go back to the **Zone Style** dialog and turn the disabled zones back on by selecting all rows (Control-A, or Command-A on Mac, is a handy keyboard shortcut for this), then toggling on the Show checkboxes for any disabled zone. This toggles on all selected zones.

You can now close both the **Zone Style** and **Specify Equations** dialogs.

Step 7: Create XY Plot of Slice

We're ready to create an XY plot of the slice. We'll put it in its own frame: frames are the Tecplot 360 way of showing multiple plots on a page.

First, click the frame tool in the Tecplot 360 toolbar.



Next, use it to draw the new frame in the workspace. The placement and size don't matter, since we'll have Tecplot 360 set it up nicely for us in a moment. Click and hold the mouse button somewhere in your plot, then drag down and to the right to create the frame. Release the mouse button when a rectangle is visible in the plot.

The new frame might look something like this.

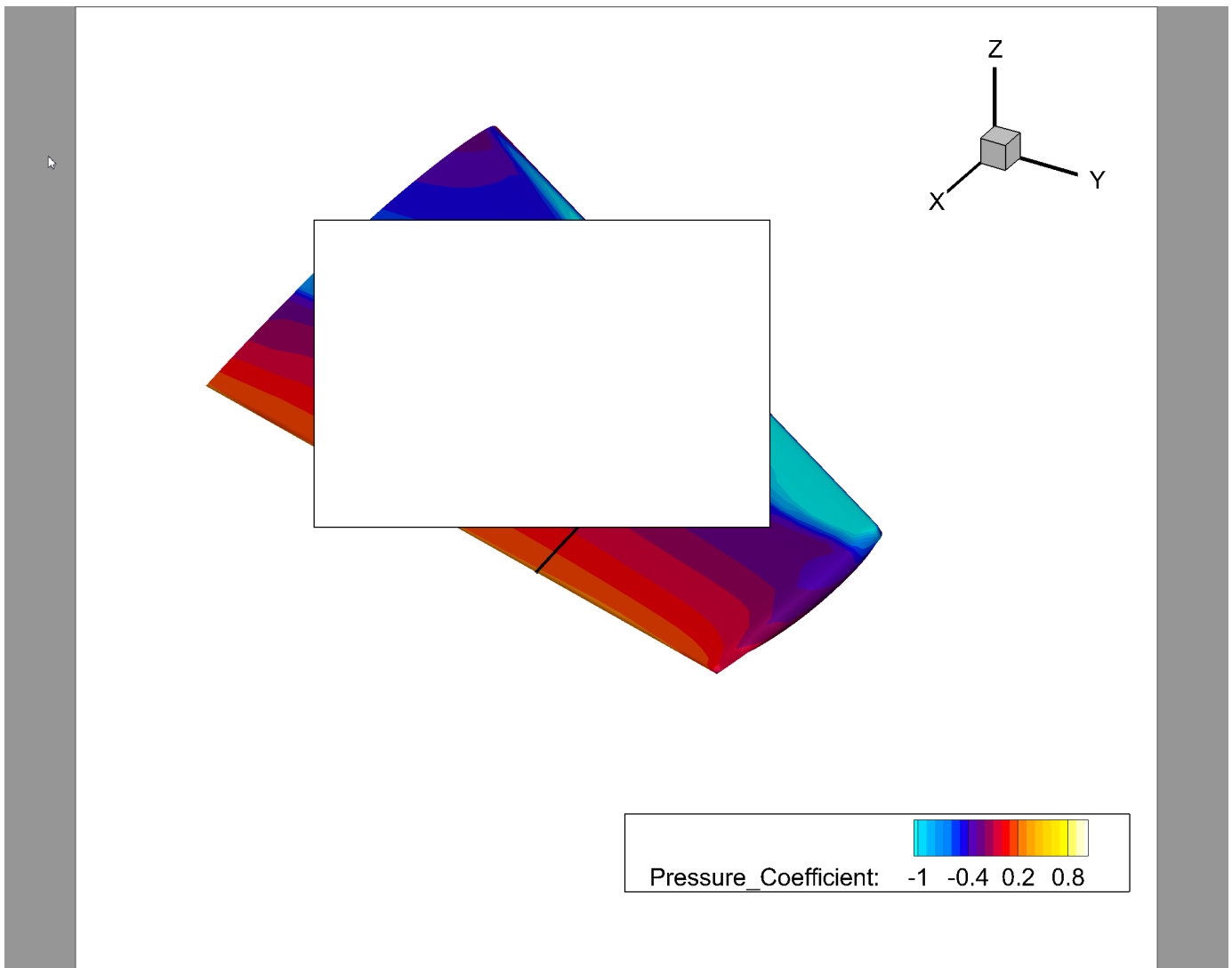

Next, choose **Frame** → **Tile Frames** in the Tecplot 360 menu bar. The **Tile** dialog appears, as shown here.

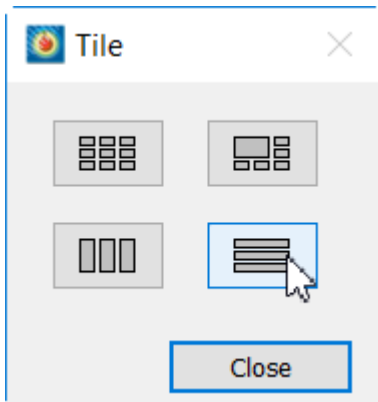

Click the bottom right button in the **Tile Frames** dialog to stack the frames on top of each other in the workspace. Then close the **Tile** dialog.

Your plot now looks something like this.

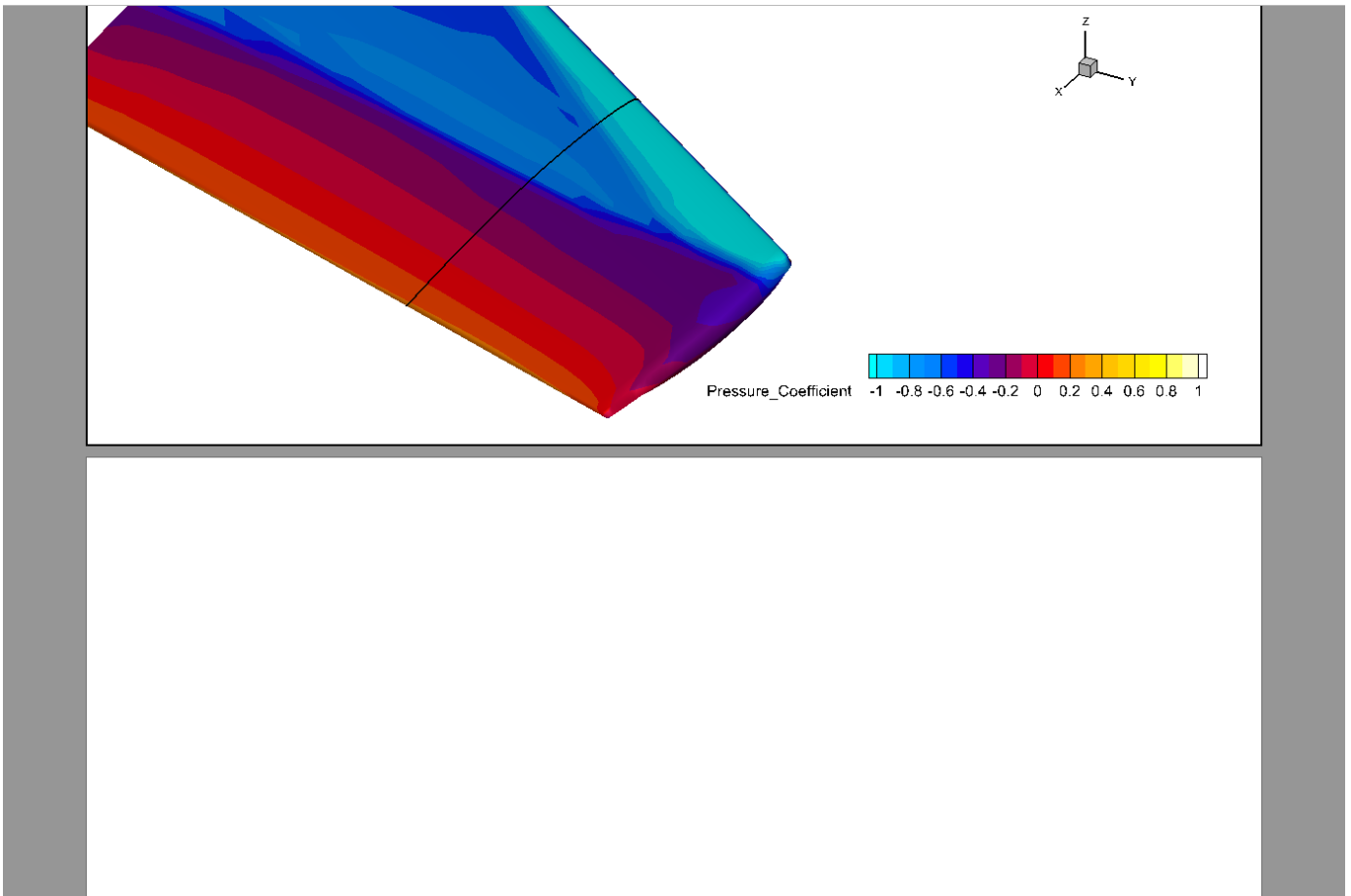

Now, using the drop-down menu at the top of the Plot sidebar, change from Sketch to XY Line.

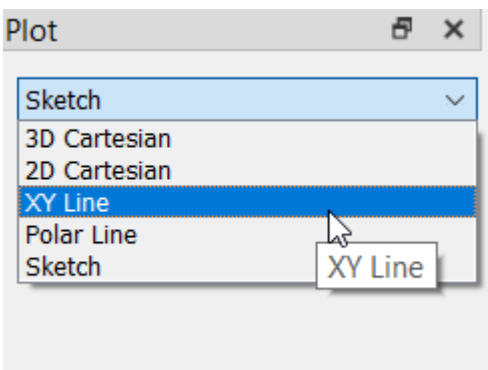

The **Create Mappings** dialog appears. In this dialog, we'll set the X-Axis to our X/L variable, our Y-Axis to `Pressure_Coefficient`, and the Zone to our extracted slice zone. The desired settings are shown here.

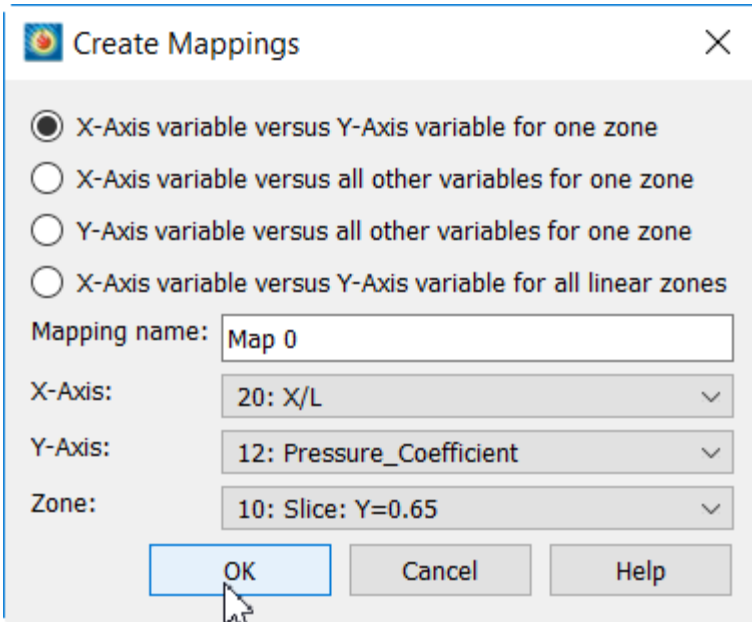

Click **OK** to create the plot, which is shown here.

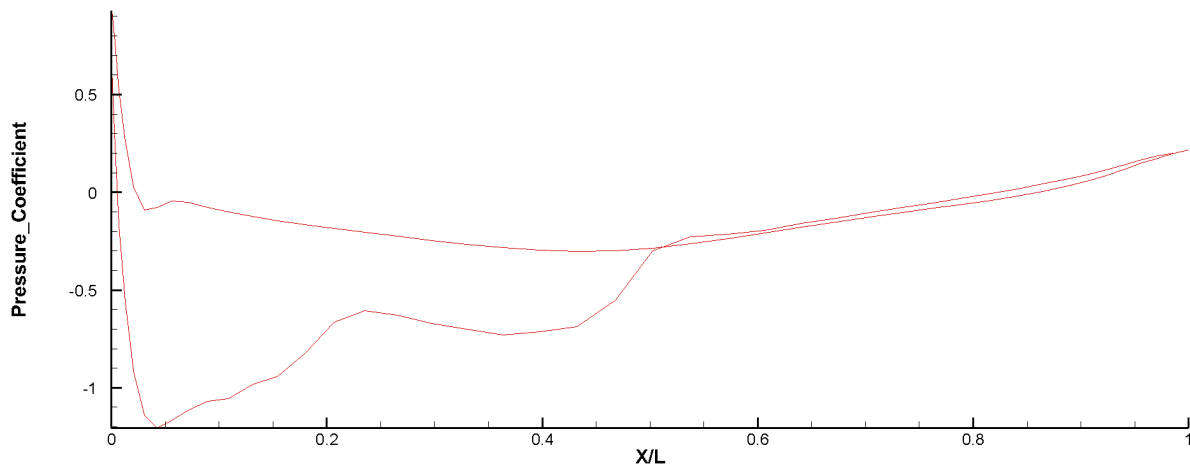

If you're familiar with Cp plots, you'll notice something odd about our current plot! The problem is that the Y axis is reversed from what it should be. Fortunately, this is easily corrected.

1. Choose **Plot** → **Axis** from the menu bar to open the **Axis Details** dialog.
2. Click Y1 at the top to choose the Y axis.
3. Toggle on the Reverse Axis Direction checkbox.

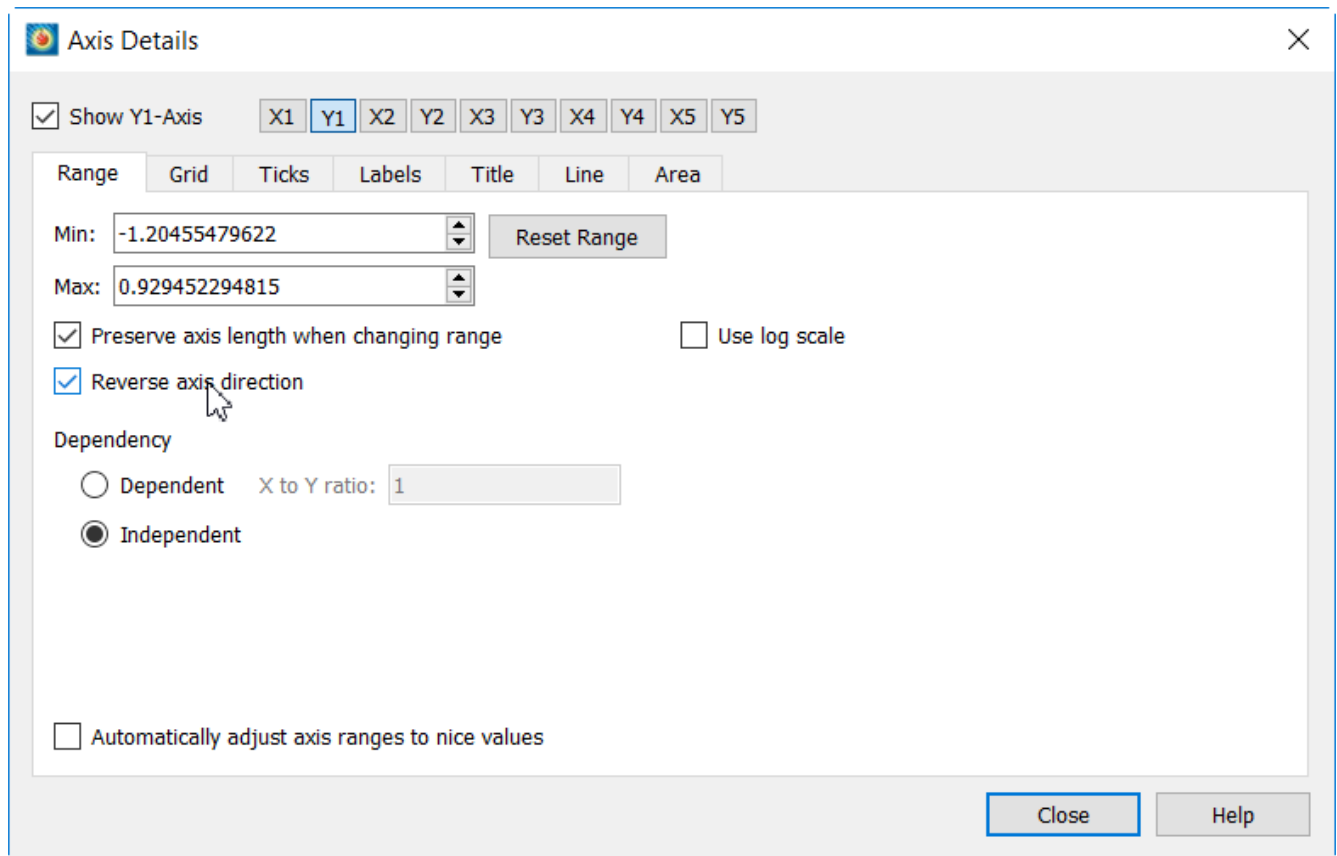

4. When the settings are as shown here, close the **Axis Details** dialog.

Our plot now looks like this. Much better.

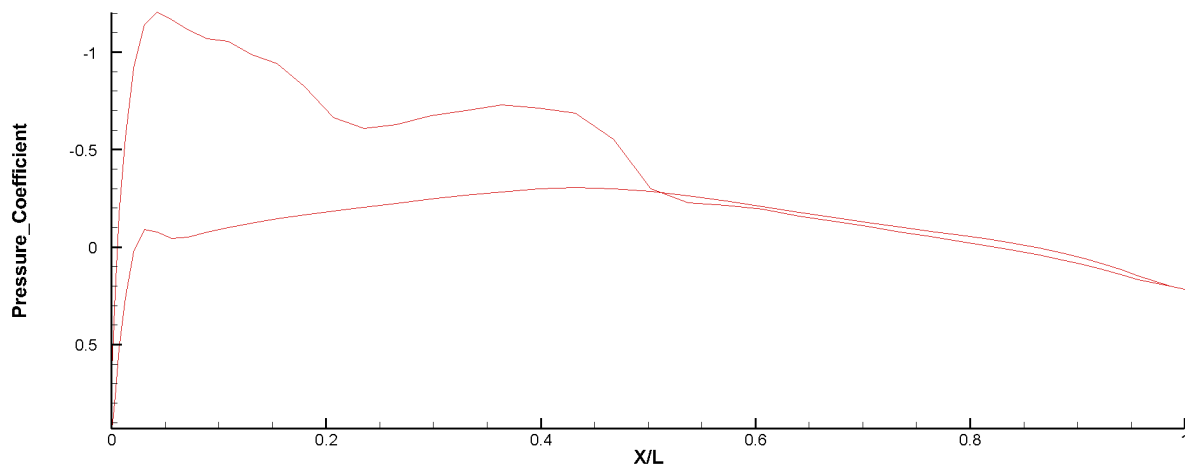

Step 8: Plot Experimental Data

We're in the home stretch now! Let's add the experimental data to our plot. First, open the **Mapping Style** dialog by clicking the **Mapping Style** button in the Plot sidebar.

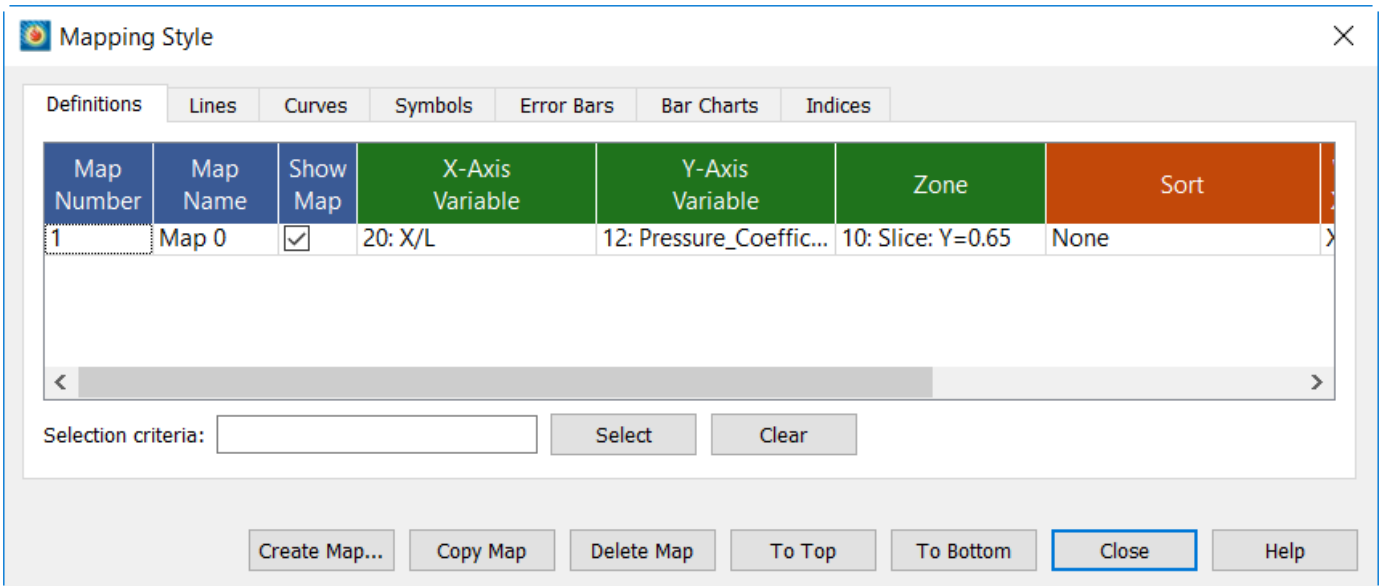

A *line map* is the Tecplot 360 way of associating (mapping) a variable with a visual style for each line in your plot. Tecplot 360 created our first line map for us when we switched to XY Line mode. The **Mapping Style** dialog is used to manage the line maps in our XY Line plot.

We want to show both the simulation and experimental data in our plot, so we'll need to create a second line map for the experimental data. The easiest way to do this is to copy the existing simulation data line map and modify it to display the experimental data.

1. Click the first row in the Mapping Style table to select the first line map.
2. Click the **Copy Map** button at the bottom of the dialog. A second line map appears in the table.
3. Right-click the Zone field in the second row of the table, then choose zone 5, **Section 3 - .65**, as the zone for the second line map. This is the experimental data for the pressure tap at 0.65 along the wing, corresponding to the position of the slice we've taken of the simulation zone.
4. Toggle on the Show Map checkbox for the second map.
5. Double-click the name of each mapping and enter an appropriate name. Especially with complex line plots with many mappings, giving your mappings good names will make it much easier to make changes to the plot. We named them as follows:
 - Map 1: CFD Simulation: $Y/b = 0.65$
 - Map 2: Experimental: $Y/b = 0.65$

The **Mapping Style** dialog and the plot should now appear as shown here.

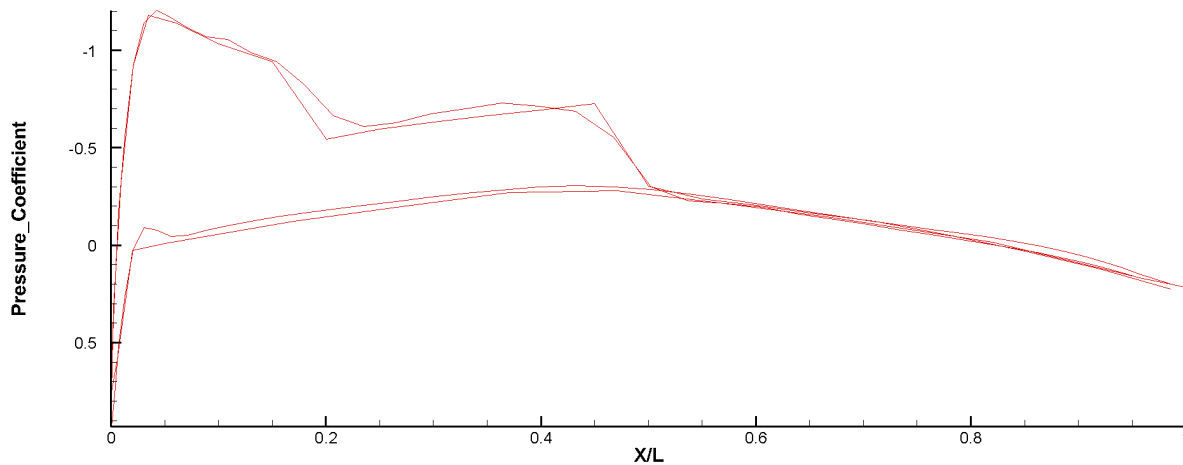
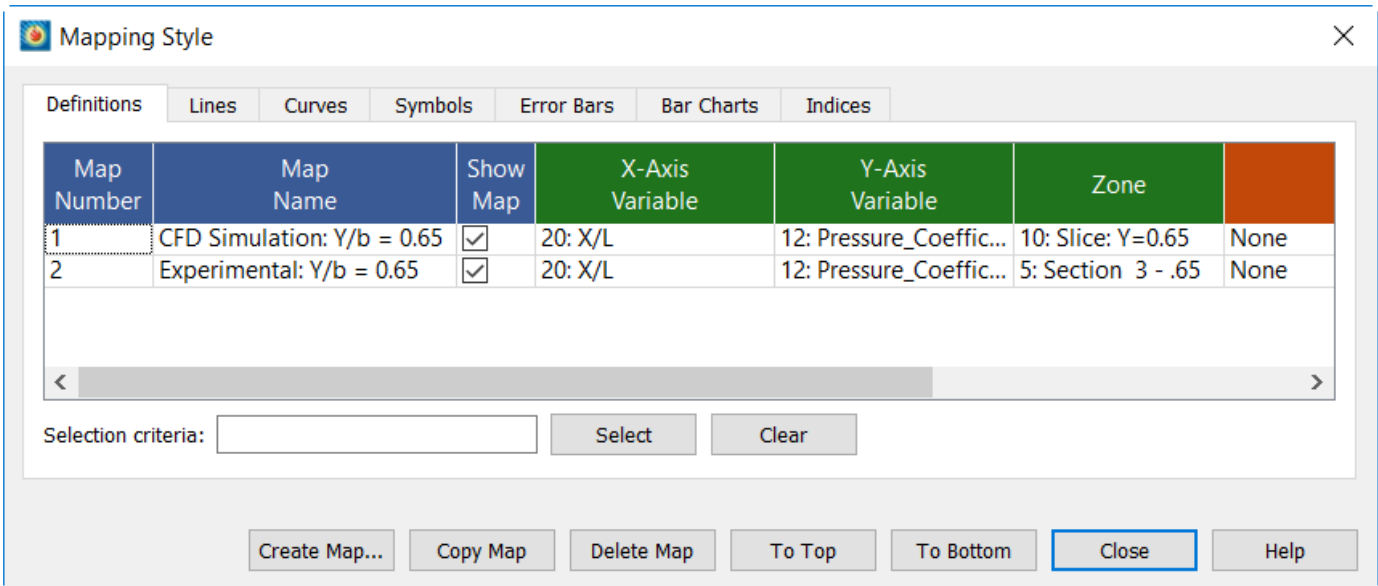

As you can see, there's a *slight* problem here: both the simulation and the experimental data have the same appearance, making it impossible to distinguish them. We can address this by using different colors for the two zones.

Additionally, the simulation data is continuous, while the experimental data, having been measured at specific points along the wing, is discrete. Therefore, we will display the experimental data using a symbol at each measurement location rather than as a line.

Finally, we have uncertainty information for the experimental data, which we can display using error bars.

All of these appearance changes can be managed using the **Mapping Style** dialog. Let's get to it.

1. Change to the Lines page of the **Mapping Style** dialog using the tabs at the top of the dialog, then toggle off the Show Lines checkbox for the Experimental mapping.
2. Also on the Lines page, right-click the line thickness for the CFD Simulation map and change it to 0.40% to make it thicker.

The Lines page should appear as follows.

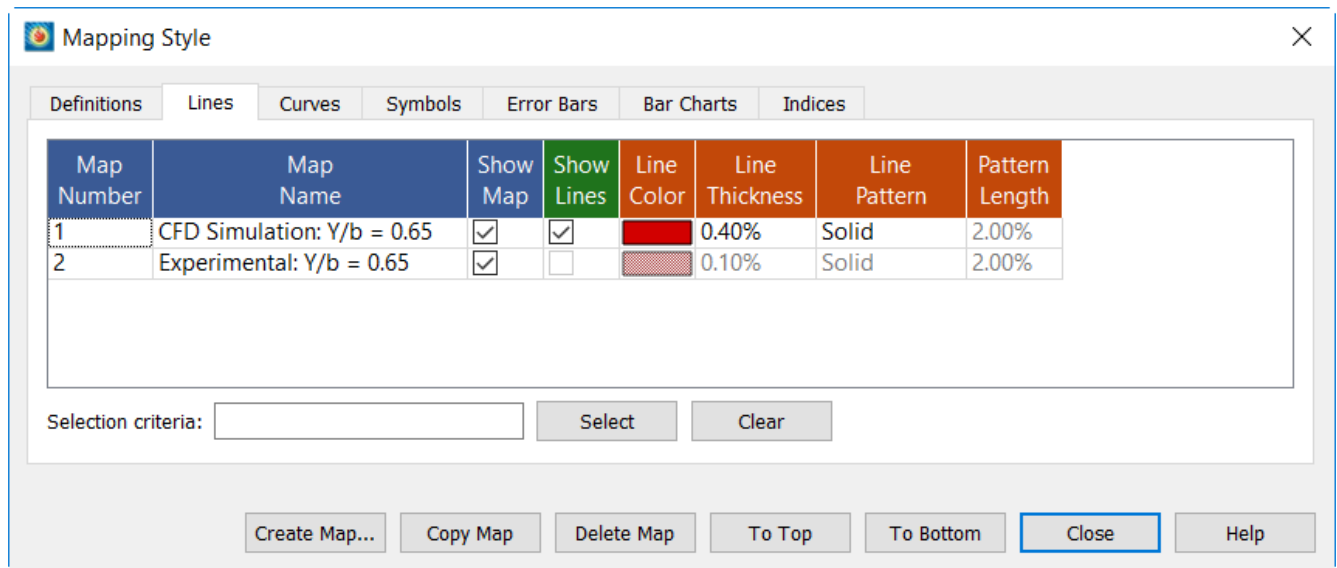

3. Change to the Symbols page of the **Mapping Style** dialog. You'll note that all settings are grayed out here. To use the Symbols settings, we must enable the Symbols of our plot by toggling on the Symbols checkbox on the Plot sidebar.

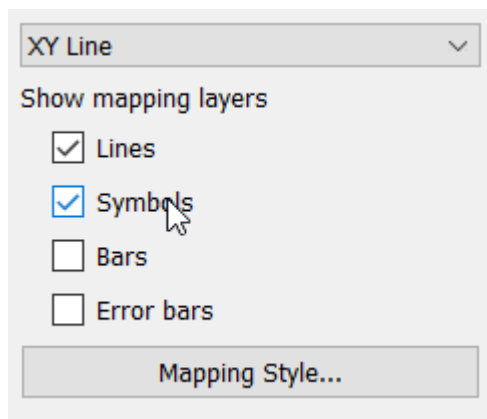

4. Now that the Symbols settings are available in the **Mapping Style** dialog, turn the symbols off for our CFD Simulation map.
5. Right-click the Outline Color for the Experimental map and choose a blue using the Color Chooser.
6. The symbols are way too big, so right-click the Symbol Size for this map and change it to 1.0. The Symbols page should look as follows.

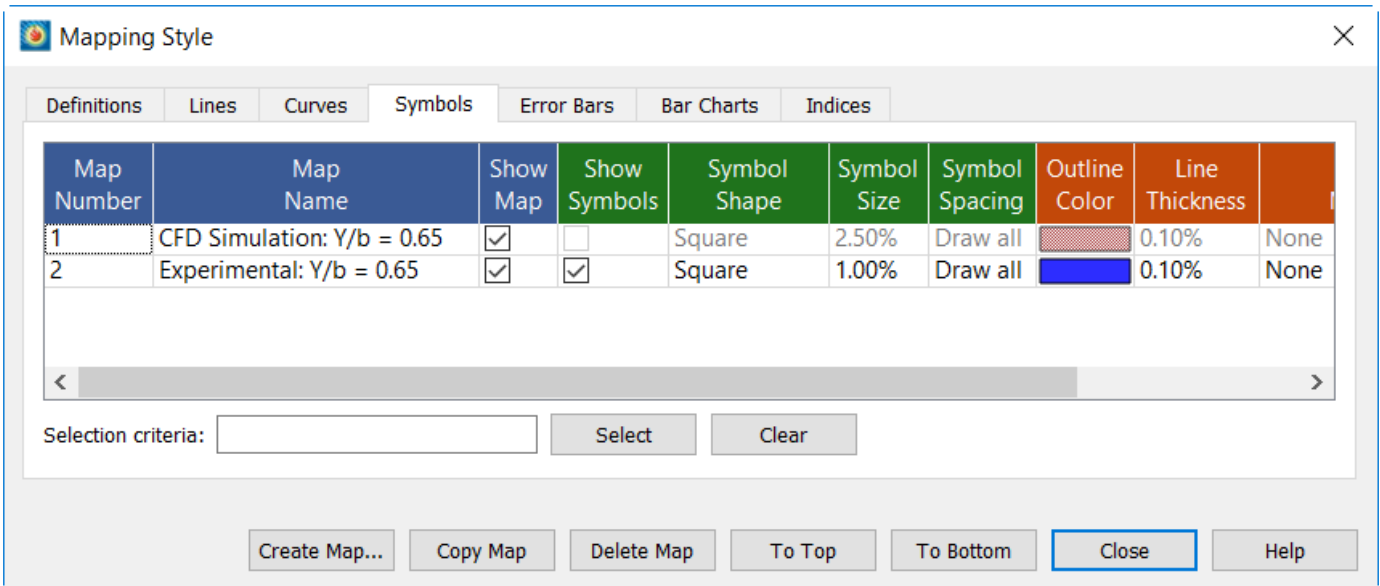

Scenic Detour: Line Map Context Menu and Toolbar

Earlier in this tutorial sequence, we suggested you right-click on your 3D plot to discover a quick way to make changes to your zone style—without a trip to the **Zone Style** dialog. Try right-clicking on a line in your plot to reveal the line map context menu and toolbar (shown at right). Then try to do the next step, adding error bars, using the context menu rather than the **Mapping Style** dialog.

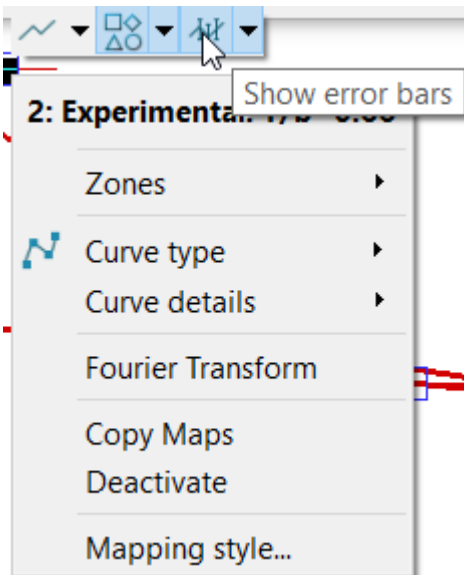

Step 9: Add Error Bars

The experimental data includes an error variable calculated from data NASA provides about the Onera M6 wing, namely that the measurement error for the pressure taps was found to be ± 0.02 . Let's add error bars to the plot to visualize this information.

1. Change to the Error Bars page of the **Mapping Style** dialog. As with the Symbols page, all the Error Bars settings are initially grayed out. So we will need to toggle on Error Bars in the Plot sidebar to enable the Error Bars layer, which makes these settings available in Mapping Style.

2. With the Error Bar settings available in the **Mapping Style** dialog, toggle on Show Error Bars for the Experimental map.
3. Right-click the Error Bar Variable for this map and choose variable 23, "Cp Error."
4. Right-click the Error Bar Color for the map and choose the same blue you earlier chose for the map's symbols.

The Error Bars page should now look as follows.

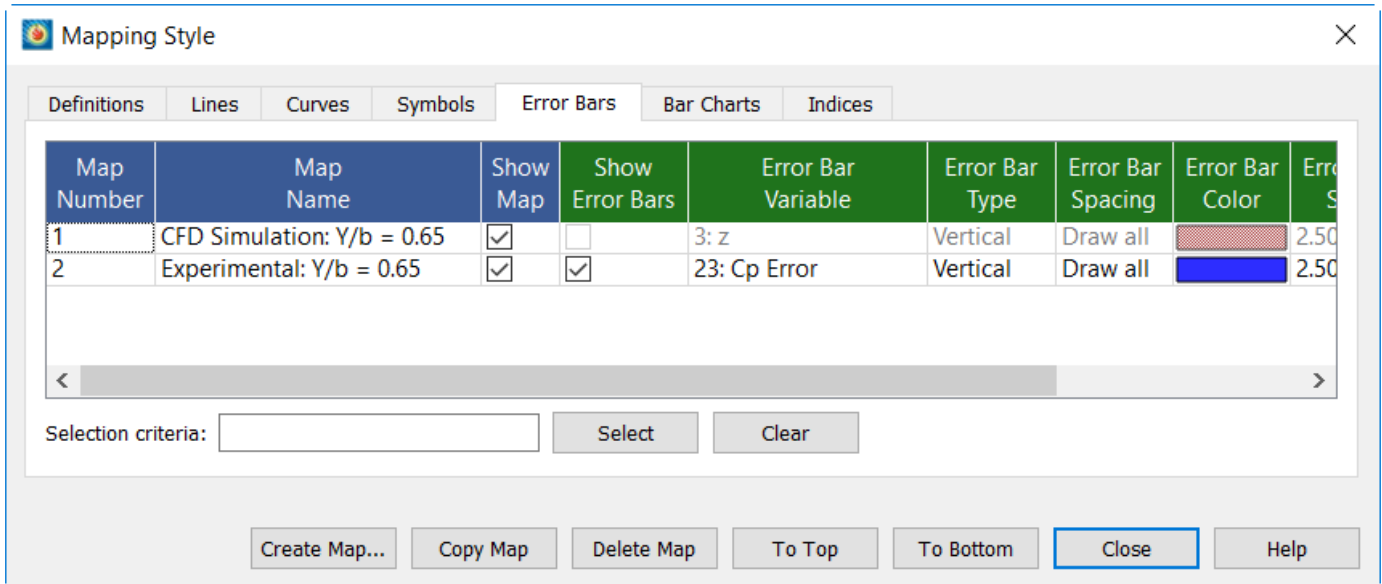

You can now close the Mapping Style dialog. The plot should look as follows.

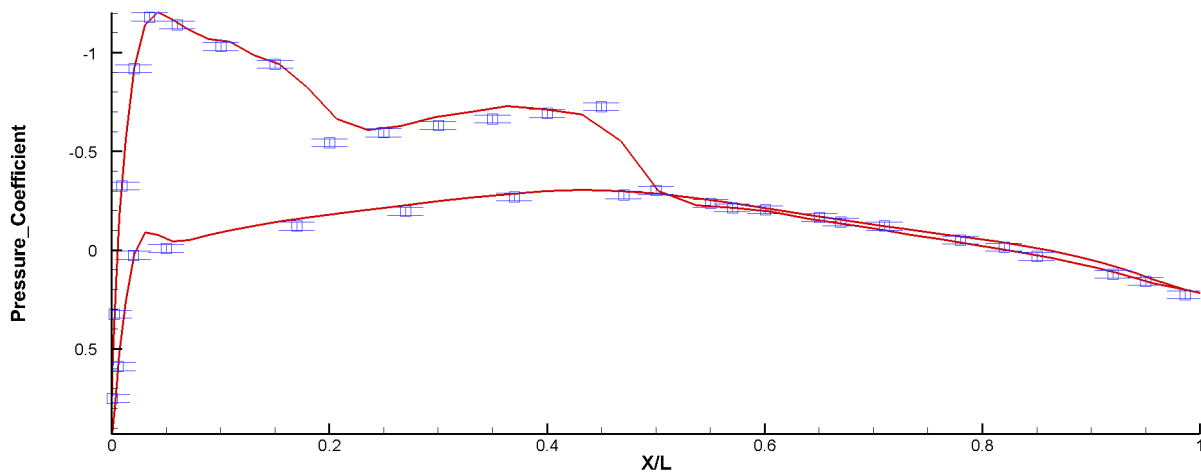

Step 10: Final Polishing

As a finishing touch, we can add a legend to the plot. Choose **Plot** → **Line Legend** from the Tecplot 360 menu to open the **Legend** dialog, then toggle on the Show Line Legend checkbox.

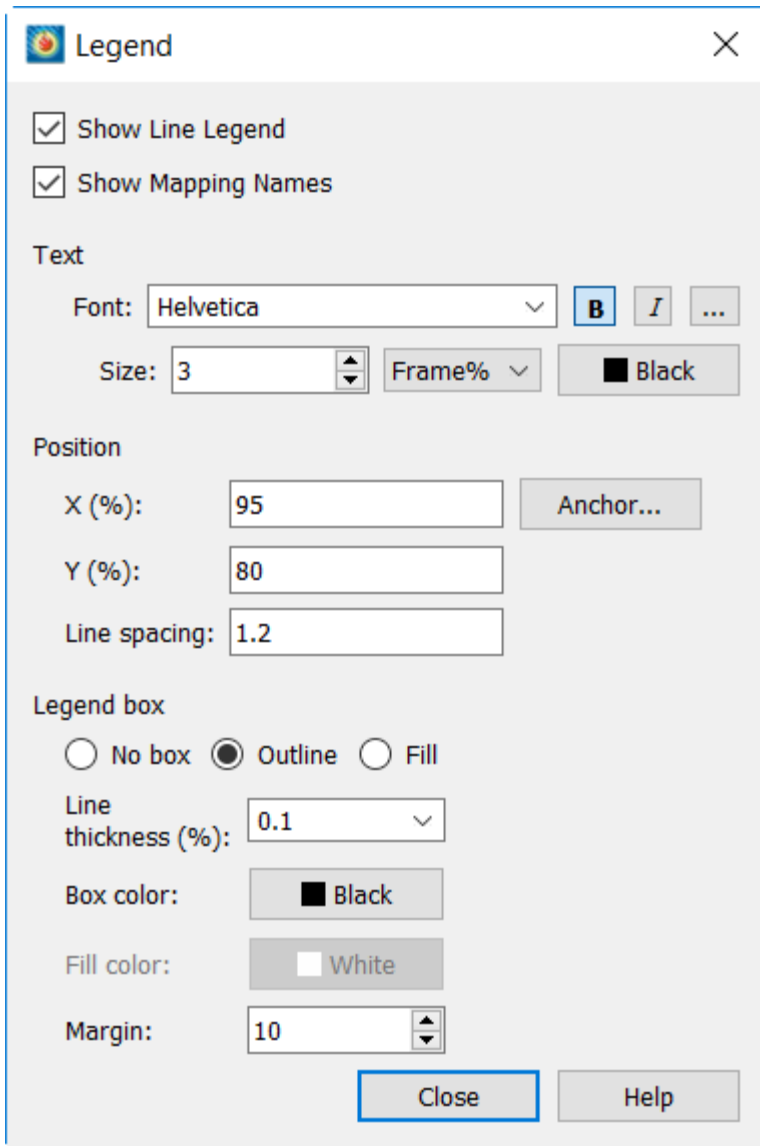

Let's also choose **View** → **Nice Fit to Full Size** to make the plot look a little less crowded against the axes.

The final plot (including both frames) is shown below.

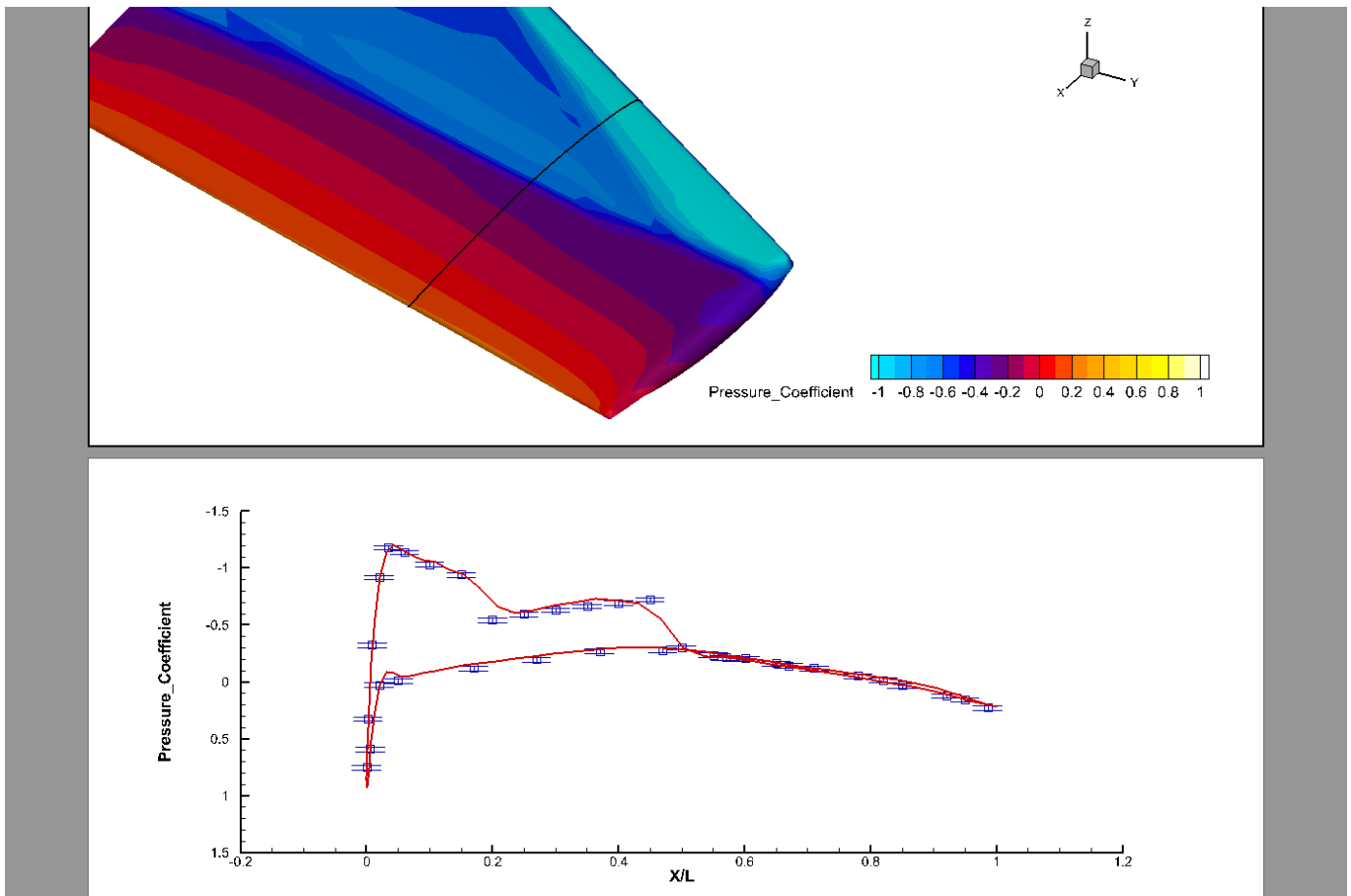

Naturally, a Tecplot 360 layout package (.lpk) file containing a snapshot of the final result of this tutorial segment is in `OneraM6wing/finallayouts/ExternalFlowVideo3.lpk` in the `examples` folder in your Tecplot 360 installation folder.

Next Steps

This concludes the External Flow tutorial for Tecplot 360. At this point, you may wish to dig in to the User's Manual or Help (**Help** → **Tecplot 360 Help**) for more details on the product in general or on specific features you've used in this tutorial.

We regularly create videos to introduce users to features of the product, not just introductory topics for new users, but also for advanced users and to highlight new features in the latest release. You can find these on our Web site at www.tecplot.com/category/tecplot-360-videos/?product=360 or on our YouTube channel at www.youtube.com/user/tecplot360.

Understanding Volume Surfaces

This tutorial shows an example of how Tecplot 360 renders volume surfaces using Surfaces to Plot. For this tutorial, we will be using the duct flow dataset which can be found in the [Getting Started Bundle](#).

This tutorial contains only one segment. The level of complexity is shown below.

Number and Level	Title and Description
1 - <i>Beginner</i>	Understanding Volume Surfaces - Load the Duct Flow dataset and understand how Tecplot views volume surface data.

A video version of this tutorial is available on the Web at www.tecplot.com/2016/03/04/understanding-volume-surfaces. The videos may have minor differences from the printed version of the tutorial in this manual, but they end up in the same place.

Understanding Volume Surfaces

Step 1: Launch Tecplot 360 and Load the Data Set

Start Tecplot 360 from the Start menu (Windows), by typing `tec360` in a terminal window (Linux), or by double-clicking the application icon in the Applications folder (Mac). We will show the Windows version of Tecplot 360 in this document, but the product looks substantially the same on other platforms.

To begin loading the surface plot data, click **Load Data** at the top of the Welcome Screen. (You may also choose **Load Data** from the **File** drop-down menu in the menu bar, or click the folder icon, second from the left, in the toolbar. These other methods are convenient when the Welcome Screen isn't visible.)

The Load Data dialog appears.

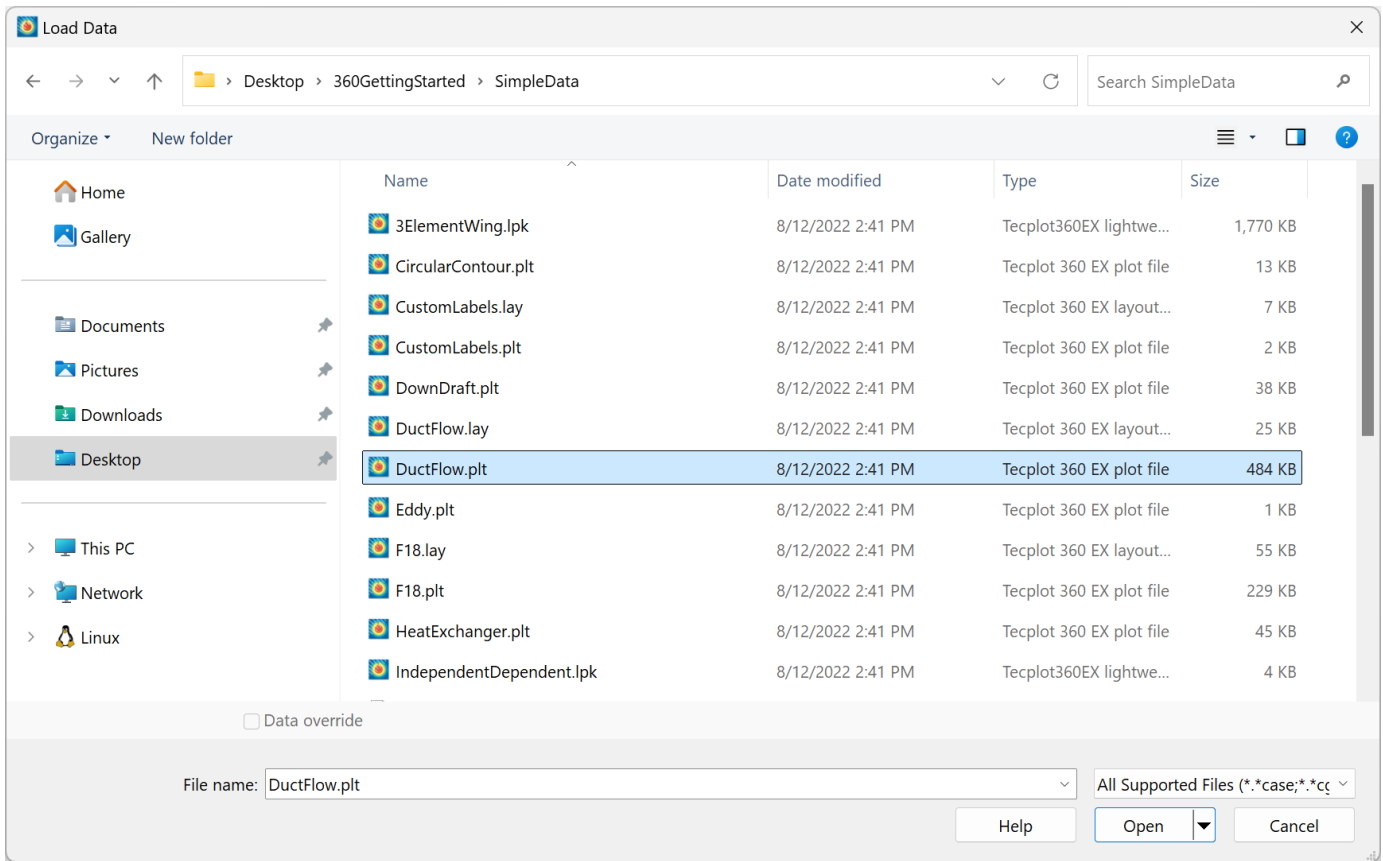

Navigate to the `examples/SimpleData` directory located in the installation folder of Tecplot and select the `DuctFlow.plt` file. After opening this file, you'll see a 3D Cartesian plot like the one below.

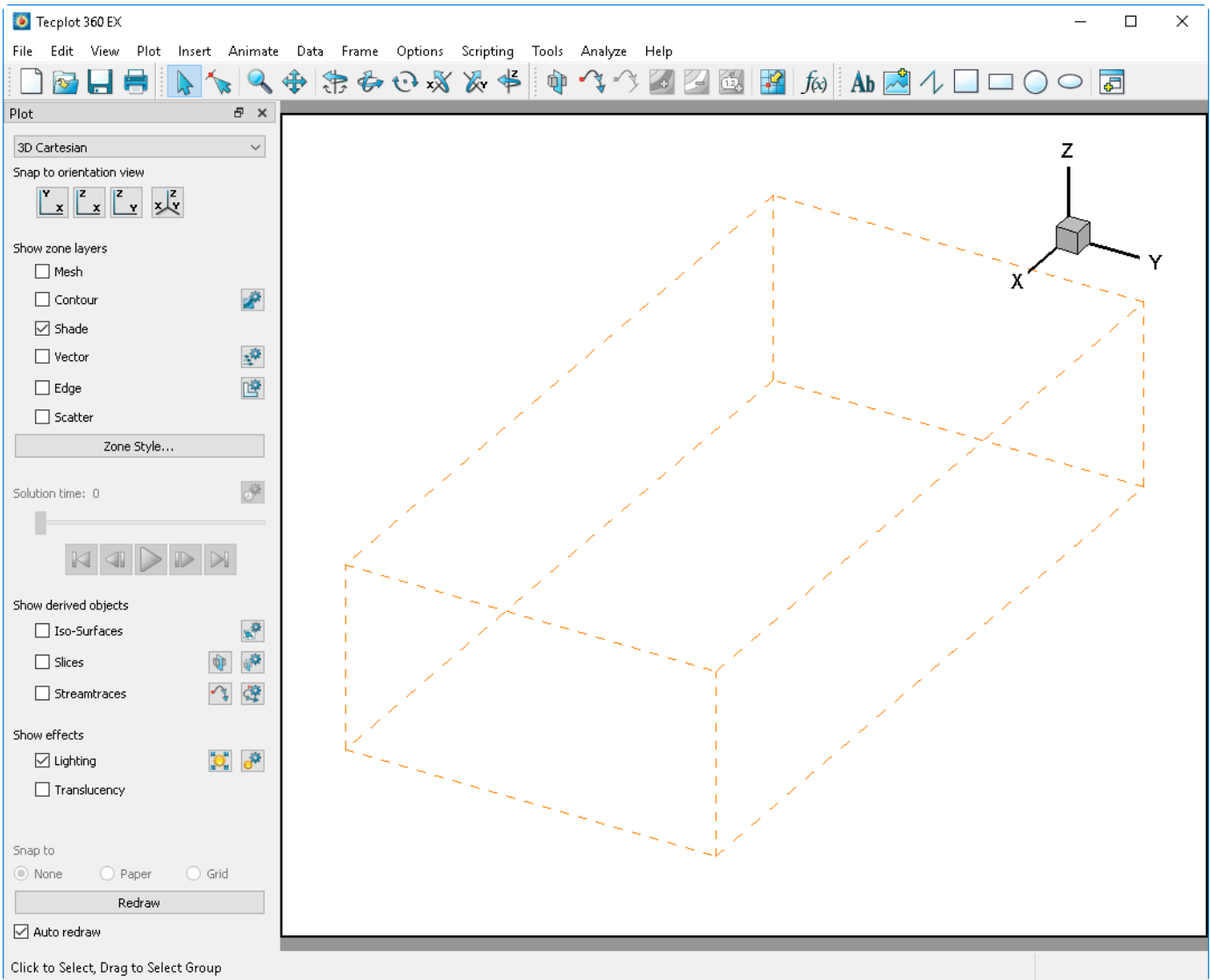

Step 2: Surfaces to Plot and the Zone Style dialog

Currently we are looking at an empty box surrounded by orange dashed lines. These lines represent the boundary of the volume zones with no style applied. To understand what we are looking at, let's look at the Surface tab of the **Zone Style** dialog:

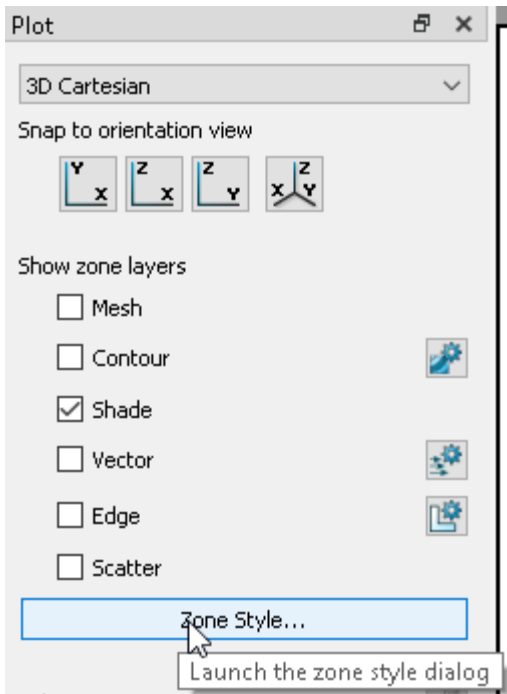

- Open the **Zone Style** dialog from the Plot sidebar.
- Select the **Surfaces** tab located at the top and notice the Surfaces to Plot heading.

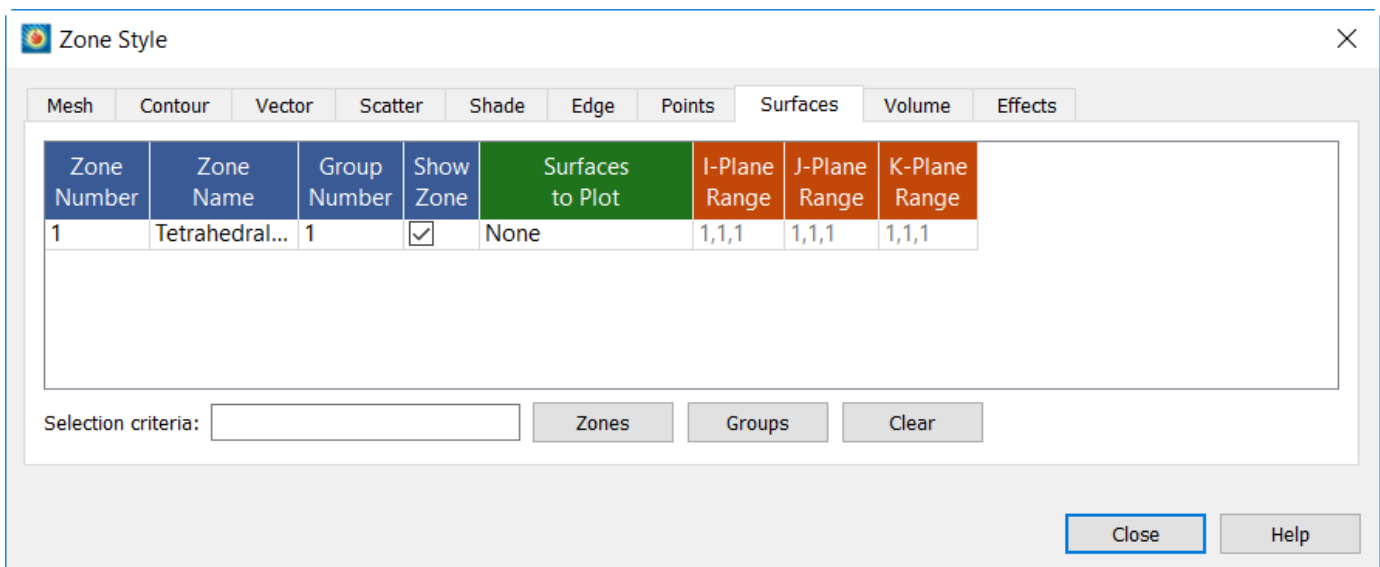

For performance reasons, the default option for **Surfaces to Plot** is set to "none" on volume zones. When you have a volume zone where you'd like to see the surface data then change this option. Note that if surface zones are in the dataset, they would be shown in the Zone Style dialog as "N/A".

Step 3: Contours and Surface Data

Now let's turn on Contour from the Plot sidebar. To show contours, however, Tecplot 360 must represent this on some sort of surface. Since this data only contains volume zones, a Question dialog appears asking to display the surfaces of volume zones. Alternatively, enabling the mesh, contour, shade, vector or scatter layer option on the plot sidebar will ask you if you want surfaces turned on for

active zones.

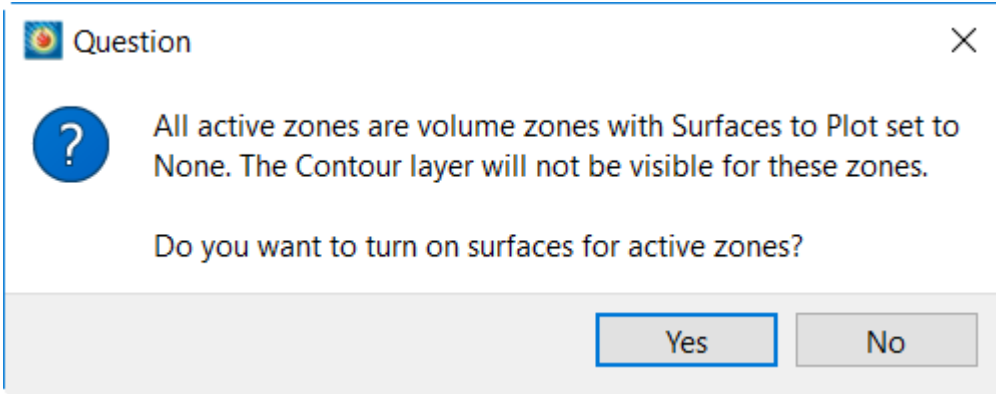

Turning on the surfaces of volume zones can be a resource-heavy operation as it requires loading the entire volume zone and calculating which cells represent the outer surface.

Clicking **Yes** on the Question dialog allows Tecplot 360 to change the Surfaces to Plot option in the Zone Style dialog. The volume surfaces will now be contoured by the first variable that is not an axis variable.

Step 4: Changed Surfaces to Plot in the Zone Style Dialog

If the Zone Style dialog was closed previously, open it again by clicking the Zone Style dialog in the Plot sidebar.

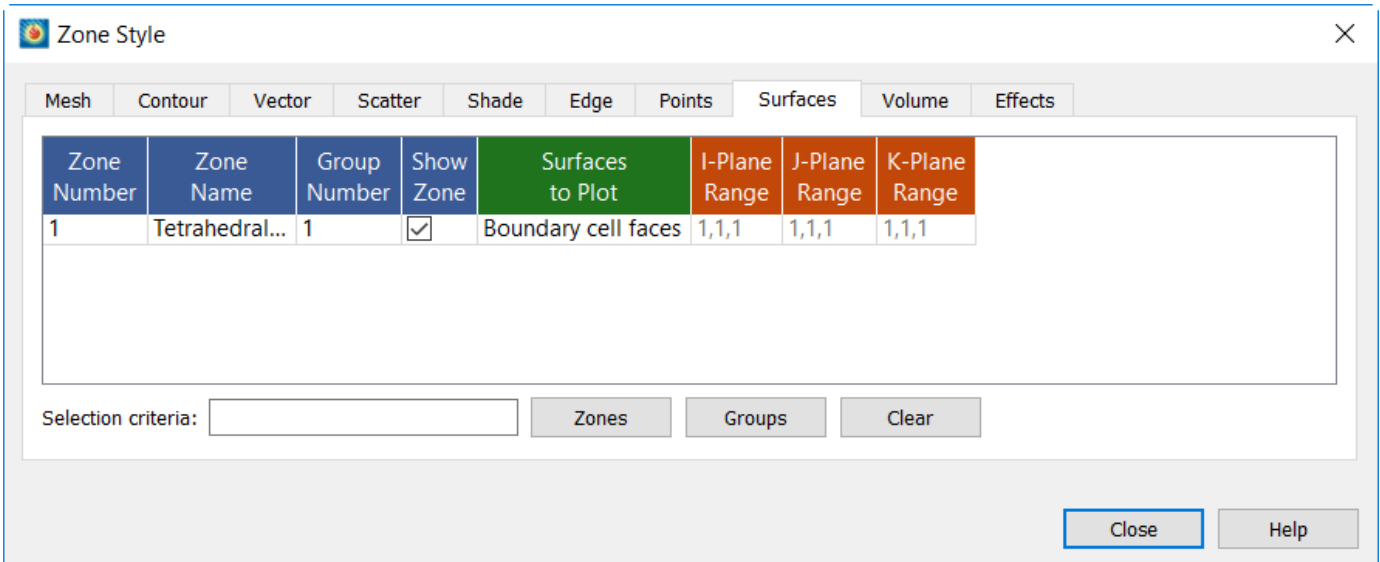

Navigating to the Surfaces tab, you'll see that the Surfaces to Plot heading has changed to **Boundary cell faces** which allows us to see the contour of surfaces of exposed boundary cells.

The resulting plot should look similar to what is shown below. Since we did not change the Contour variable, the plot is displaying the U Vector variable.

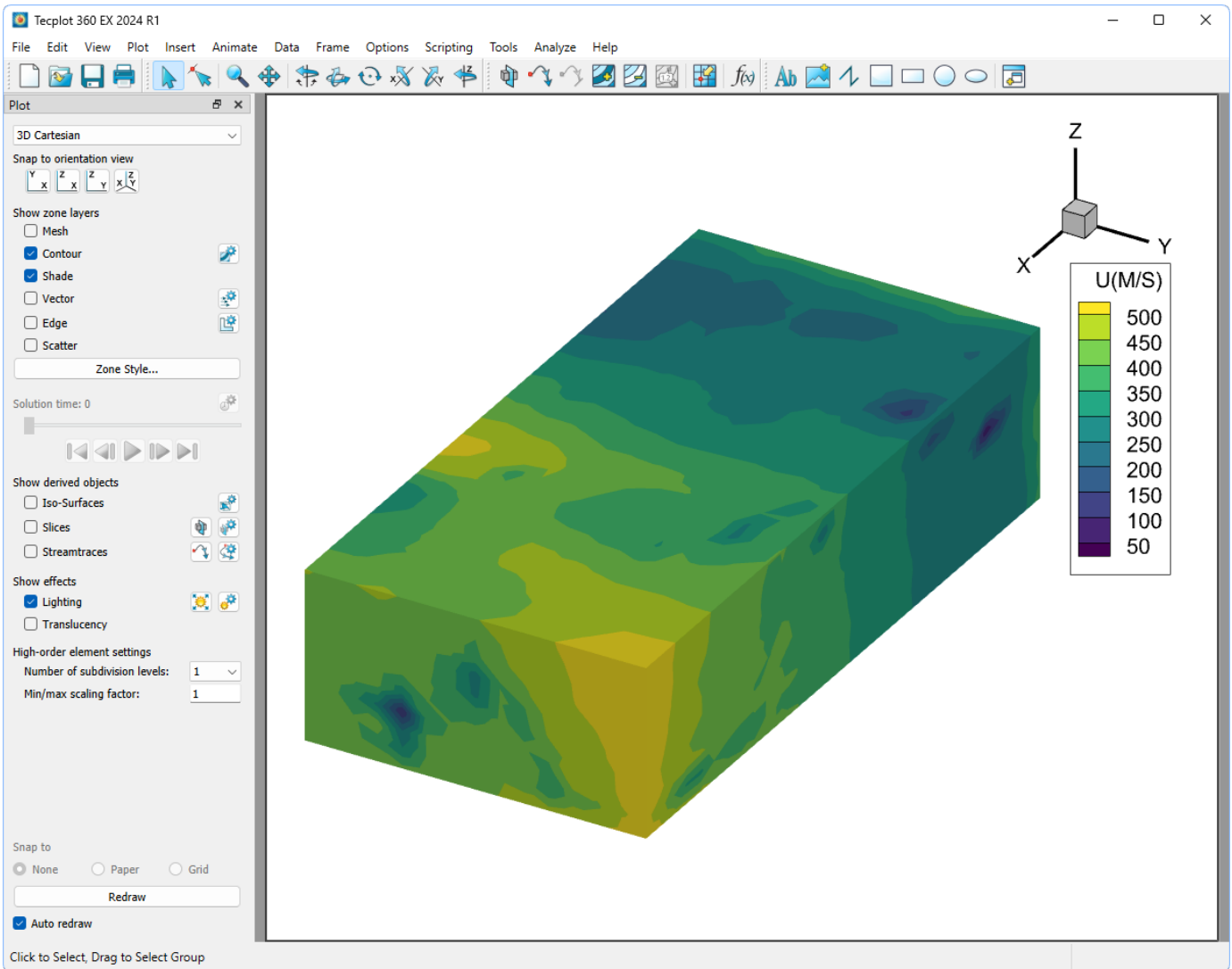

Next Steps

This concludes the Volume Surfaces tutorial for Tecplot 360. At this point, you may wish to dig in to the User's Manual or Help (**Help>Tecplot 360 Help**) for more details on the product in general or on specific features you've used in this tutorial.

We regularly create videos to introduce users to features of the product, not just introductory topics for new users, but also for advanced users and to highlight new features in the latest release. You can find these on our Web site at www.tecplot.com/category/tecplot-360-videos/?product=360 or on our YouTube channel at www.youtube.com/user/tecplot360.

Transient Data

This tutorial uses a vertical-axis wind turbine data set to explore the transient (time-based) capabilities of Tecplot 360. This data set comprises 127 time steps and 254 separate files in Fluent format. Each time step has two files, one for the geometry and one for the data. These files are sizable (over a gigabyte compressed), so they are not included with your Tecplot 360 installation. Instead, download the [Getting Started Bundle](#) and unzip the compressed data to a convenient location.

This tutorial is divided into four segments. We have provided a layout file for the end of each segment, so you can check your work. The segments are:

Number and Level	Title and Description
1 - <i>Beginner</i>	Loading and Exploring Transient Data - Load the wind turbine simulation data set and see how it is organized inside Tecplot 360. Add streamtraces and create an on-screen animation of the data set.
2 - <i>Intermediate</i>	Extracting Data - Use Tecplot 360 tools and techniques to reduce the amount of data that needs to be analyzed, making it easier to understand.
3 - <i>Expert</i>	Frequency Analysis Using Fourier Transform - Perform a Fourier transform to extract frequency domain information from the simulation and analyze the sources of pressure variations.
4 - <i>Expert</i>	Calculations and Contour Cutoff - Calculate a new variable by using the Tecplot 360 CFDA Analyzer. Use the Contour Color Cutoff property to isolate a region of interest in the plot.

A video version of this tutorial is available on the Web at www.tecplot.com/2016/03/25/transient-series-video-1-introduction-transient-data. The videos may have minor differences from the printed version of the tutorial in this manual, but they end up in the same places.

Loading and Exploring Transient Data

Step 1: Launch Tecplot 360 and Load the Data Set

Start Tecplot 360 from the Start menu (Windows), by typing `tec360` in a terminal window (Linux), or by double-clicking the application icon in the Applications folder (Mac). We will show the Windows version of Tecplot 360 in this document, but the product looks substantially the same on other platforms.

To begin loading the wind turbine data, click **Load Data** at the top of the Welcome Screen. (You may also choose **Load Data** from the **File** drop-down menu in the menu bar, or click the folder icon, second from the left, in the toolbar. These other methods are convenient when the Welcome Screen isn't visible.) The Load Data dialog appears.

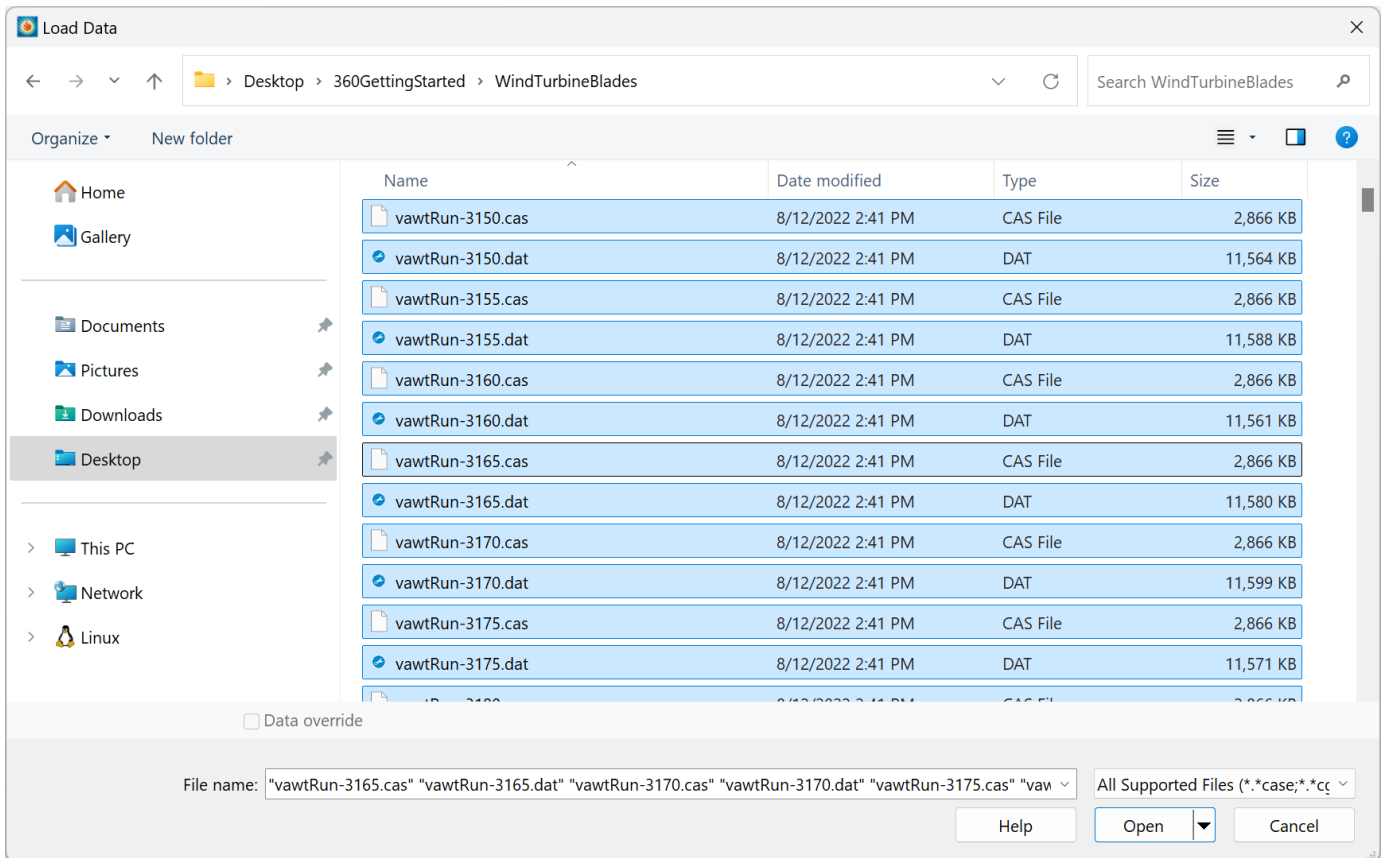

Navigate to the `windturbineblades` folder where you extracted the data files. Select all the files in this directory, for example by clicking the first one and then clicking the last one while holding the Shift key, then click **Open**. (If you can't see the files, choose **All Supported Files** in the menu at the bottom of the dialog.)

Opening all these data files will take a moment; when Tecplot 360 is finished, you'll see a 2D Cartesian plot like the one below.

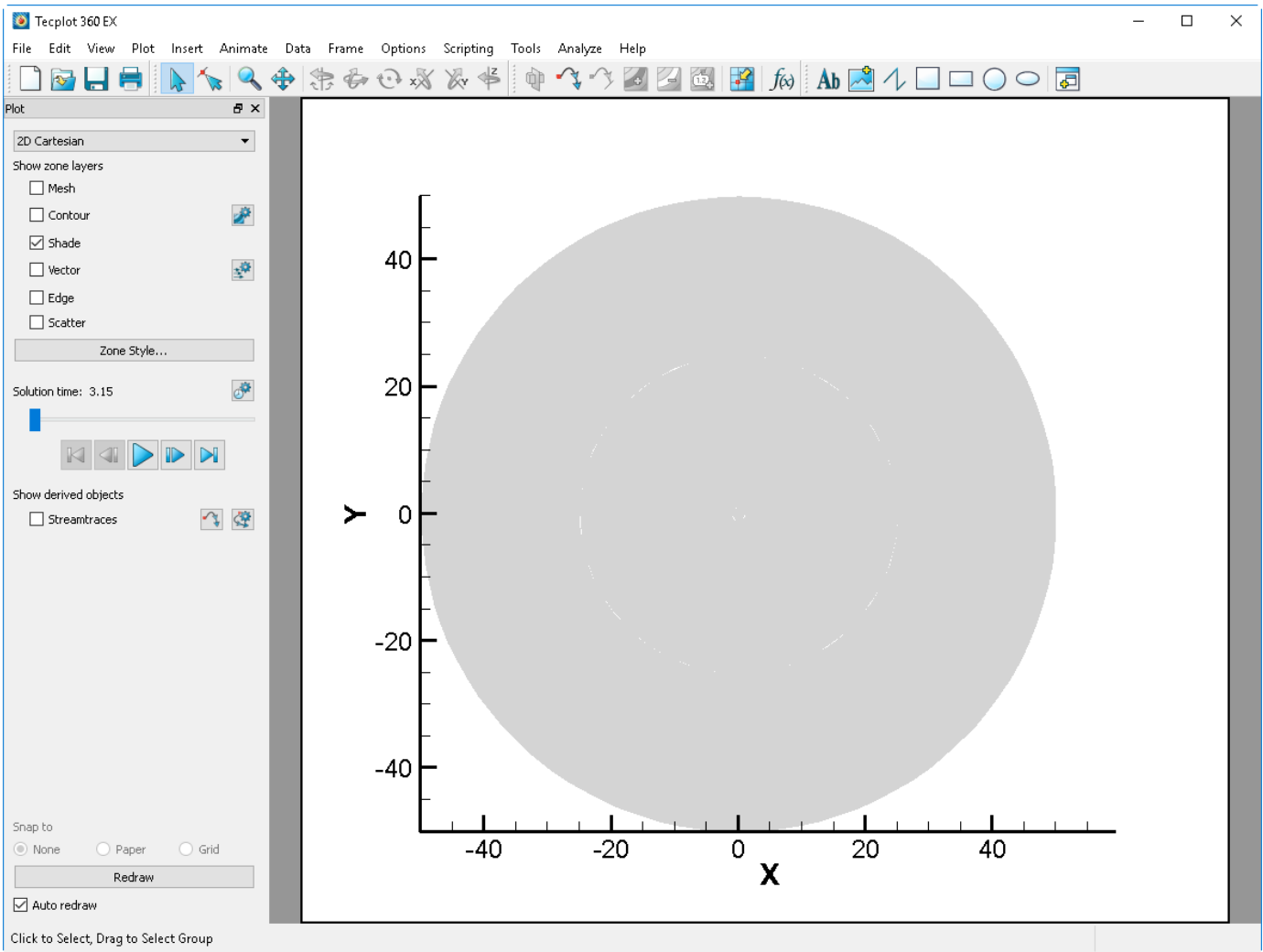

Step 2: Get A Good Look

What exactly are we looking at here? This is the full 2D fluid domain, representing the wind turbine's blades and the air surrounding them. Let's get a better view:

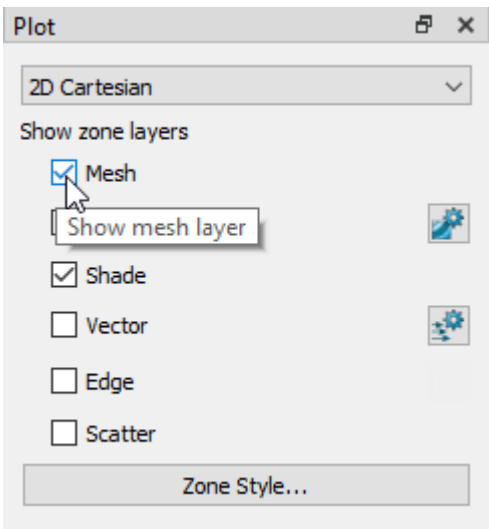

- Display the mesh by turning on the Mesh checkbox in the Plot sidebar. The mesh is a collection of

interlinked triangles; these are the individual cells that were used in the simulation.

- Click the Zoom tool on the toolbar, then use the mouse to draw a rectangle around the center of the plot. Repeat this two or three times until you see a plot like the one below.

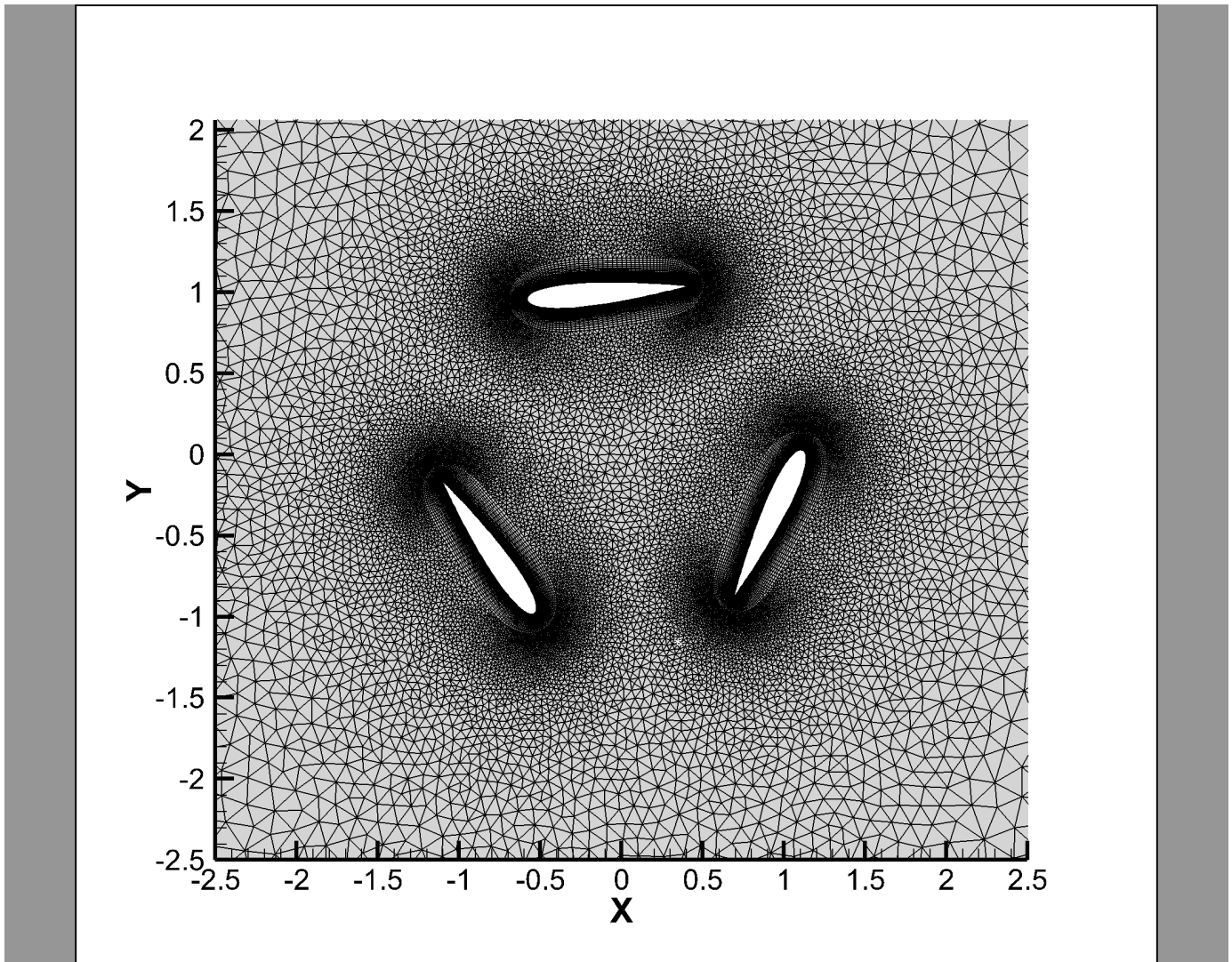

You may also zoom by placing the mouse pointer in the frame to be zoomed, holding the mouse's middle button or scroll wheel, and moving the mouse up and down.

So we can see this is a cross-section of a three-bladed vertical wind turbine. The white areas are the blades, as you can intuit from their airfoil shape. You can even infer the direction of rotation: counterclockwise.

Step 3: Dive into Data Set Info

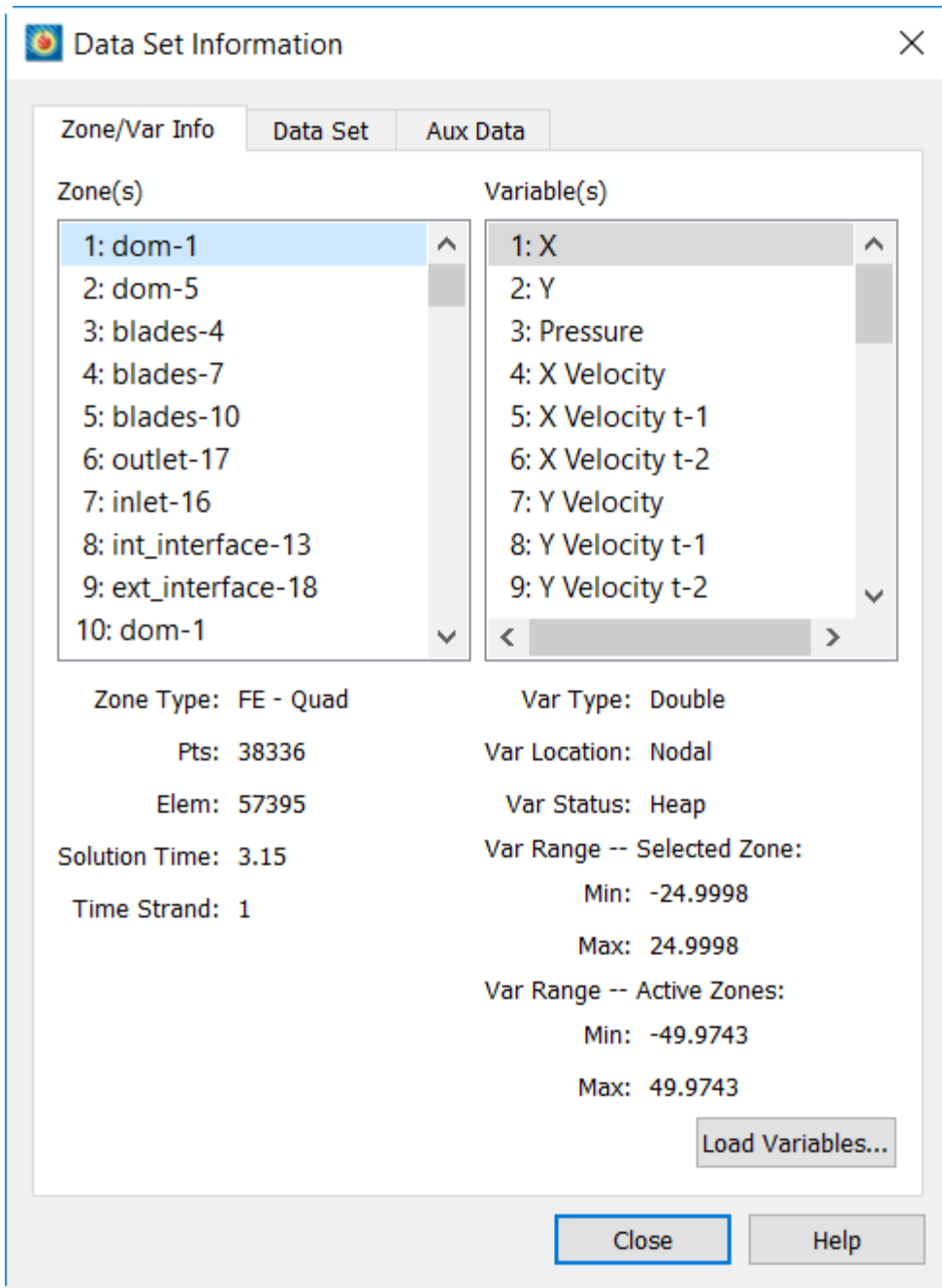

Let's take a closer look at the data we've loaded. Choose **Data Set Info** from the Tecplot 360 **Data** menu to open the Data Set Information dialog, shown here.

From here, we can see that there are more than a thousand zones in this data set. Each zone represents a region of the simulation at a particular point in time.

The number of zones may seem like a lot if you're not used to working with transient data, but if you do the math, this is only nine zones per time step. And indeed, if you look at the zone list here, you can see that the zone names repeat every nine entries: zone 1 and zone 10 are both named **dom-1**, zone 2 and zone 11 are both named **dom-5**, and so on.

So we have:

- 1143 total zones
- 127 time steps
- 9 zones per time step

If you click through the zones while keeping an eye on the Time Strand field in the panel below the zone list, you will discover that the zones that have the same names also have the same time strand. Time strands are how Tecplot 360 links the zones representing the same region throughout time.

You can also see the solution time of each zone above the time strand as you click on in the zone list. As you would expect, zones 1-9 have the same solution time, as do zone 10-18, and so forth. Thus, each set of nine zones represents the same point in time.

Step 4: Time Strands in the Zone Style Dialog

Let's close the Data Set Information dialog and open the Zone Style dialog (below) by clicking the Zone Style button in the Plot sidebar.

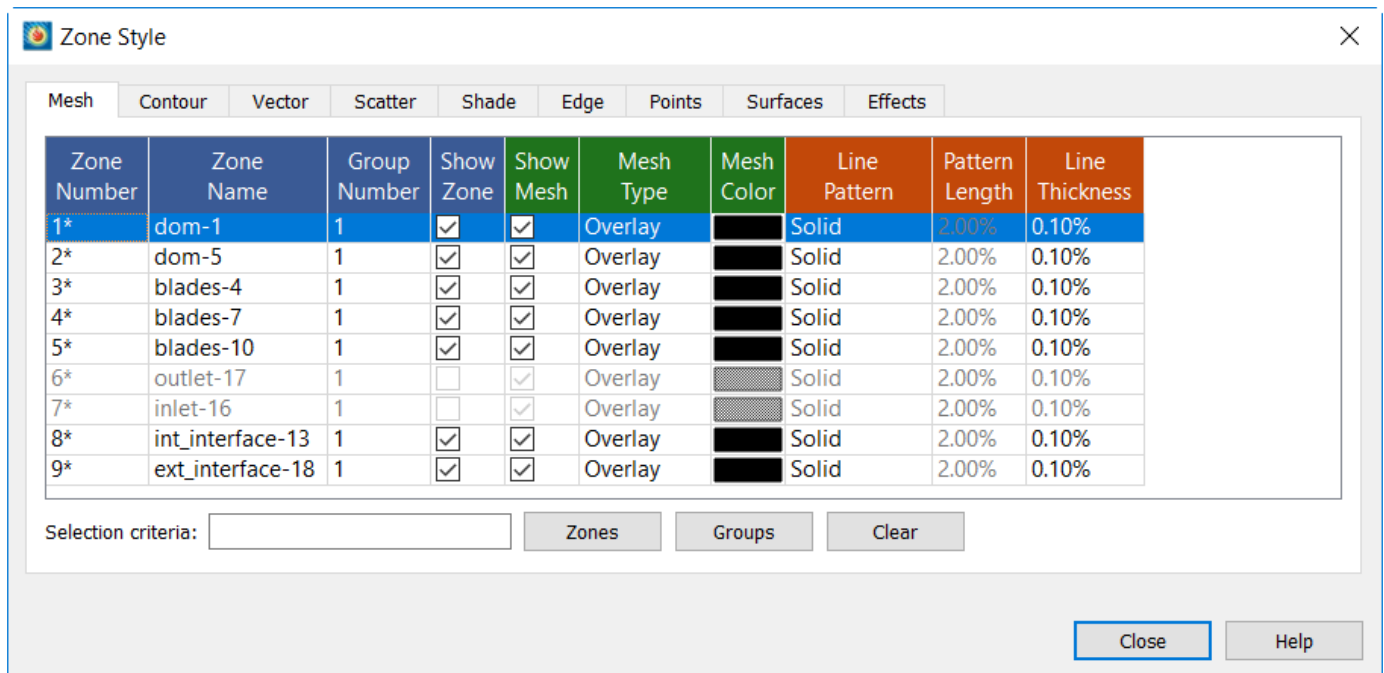

Here you'll see nine entries: one for each time strand. (The asterisk next to each zone number indicates that it's not a single zone, but a group of zones having the same time strand.) In this way, the Zone Style dialog lets you make changes to the "same zone" throughout time all at once, as you'll usually want to do, instead of having to make those changes separately at each time step. So although there are technically hundreds of zones in the data, Tecplot 360 lets you style them as though there were only nine.

We're done with the Zone Style dialog, so close it.

Step 5: Visualizing a Contour Plot

Right-click the plot to display the context toolbar and menu, as shown here. These allow you to make changes to the selected zone.

From left to right, the icons are Mesh, Contour, Vector, Shade, and Edge. Click the first icon to turn off the Mesh layer, then the second icon to turn on the Contour layer. (You can do this in the Plot sidebar if you prefer.)

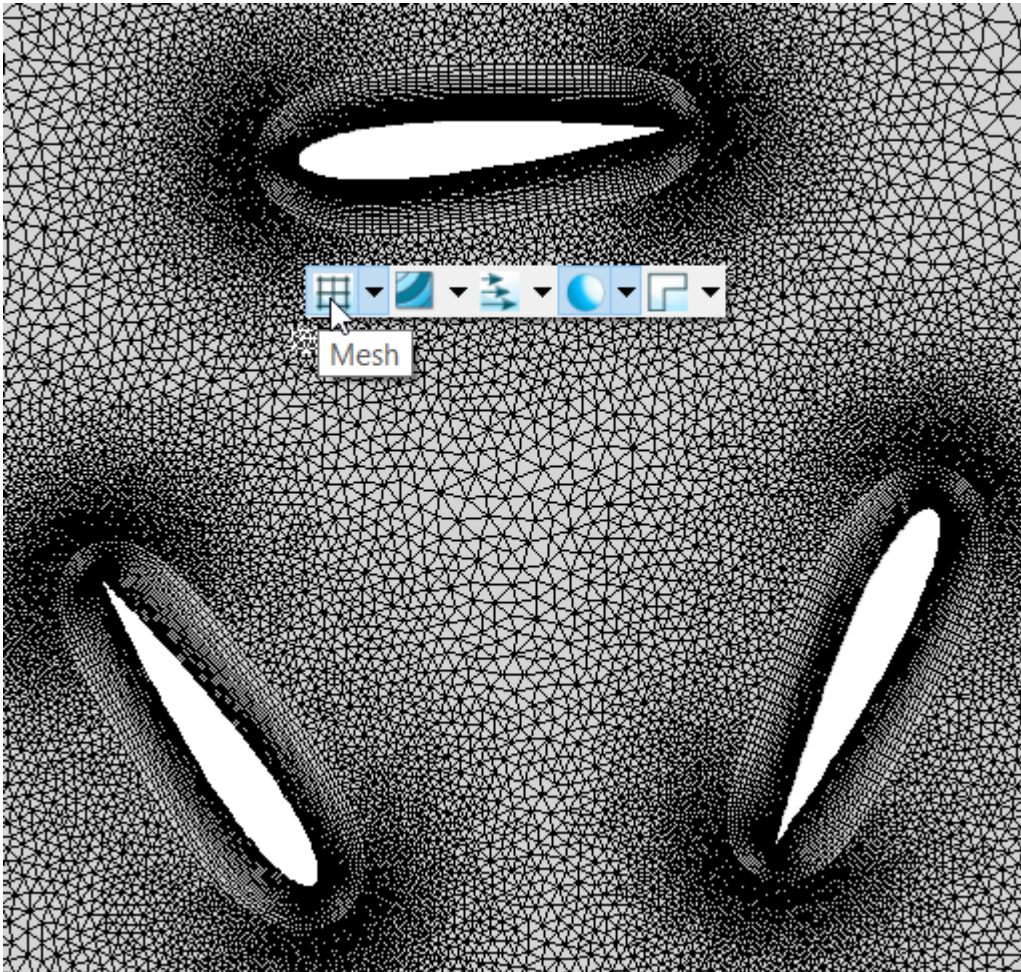

Now your screen should be showing you something like the plot below.

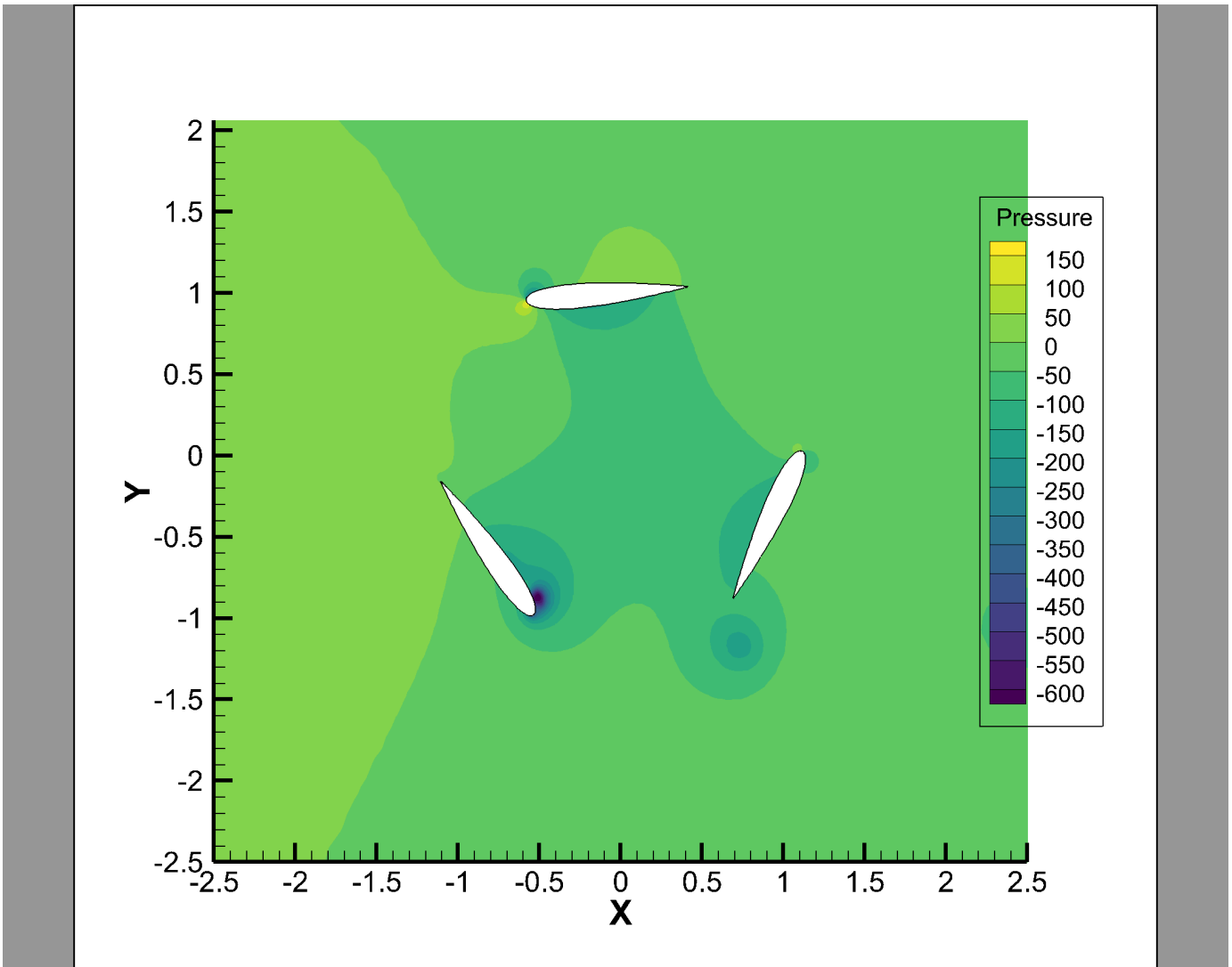

Step 6: Visualize the Flow With Streamtraces

Tecplot 360 can help visualize the flow through the wind turbine by adding streamtraces. In the Plot sidebar, turn on the Streamtraces checkbox.

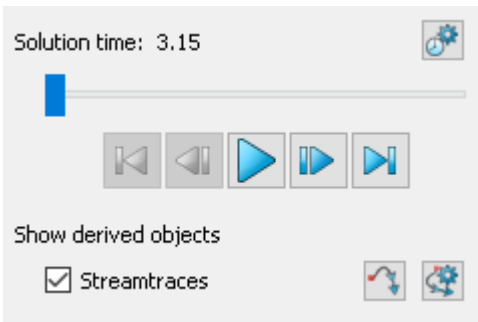

The Select Variables dialog appears to choose the variables that represent velocity through the fluid; the defaults that Tecplot 360 has chosen are correct, so just click OK.

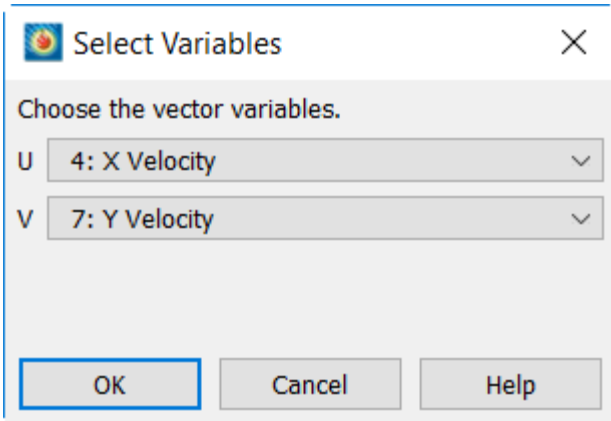

After you've accepted the vector variables, choose the streamtrace tool in the main toolbar, or in the Plot sidebar next to the Streamtraces checkbox.

You are now ready to add streamtraces to your plot, a process called *seeding*. It is convenient to seed a number of equally-spaced points along a line, which is referred to as a *rake*.

To do this, click in the plot near the top blade of the turbine, then hold the mouse button while dragging down between the two lower blades. Tecplot 360 seeds ten streamtraces at equally-spaced points along the line you placed. Tecplot 360 calculates the path of a massless particle forward and backward from each seeded point and draws the path on the plot.

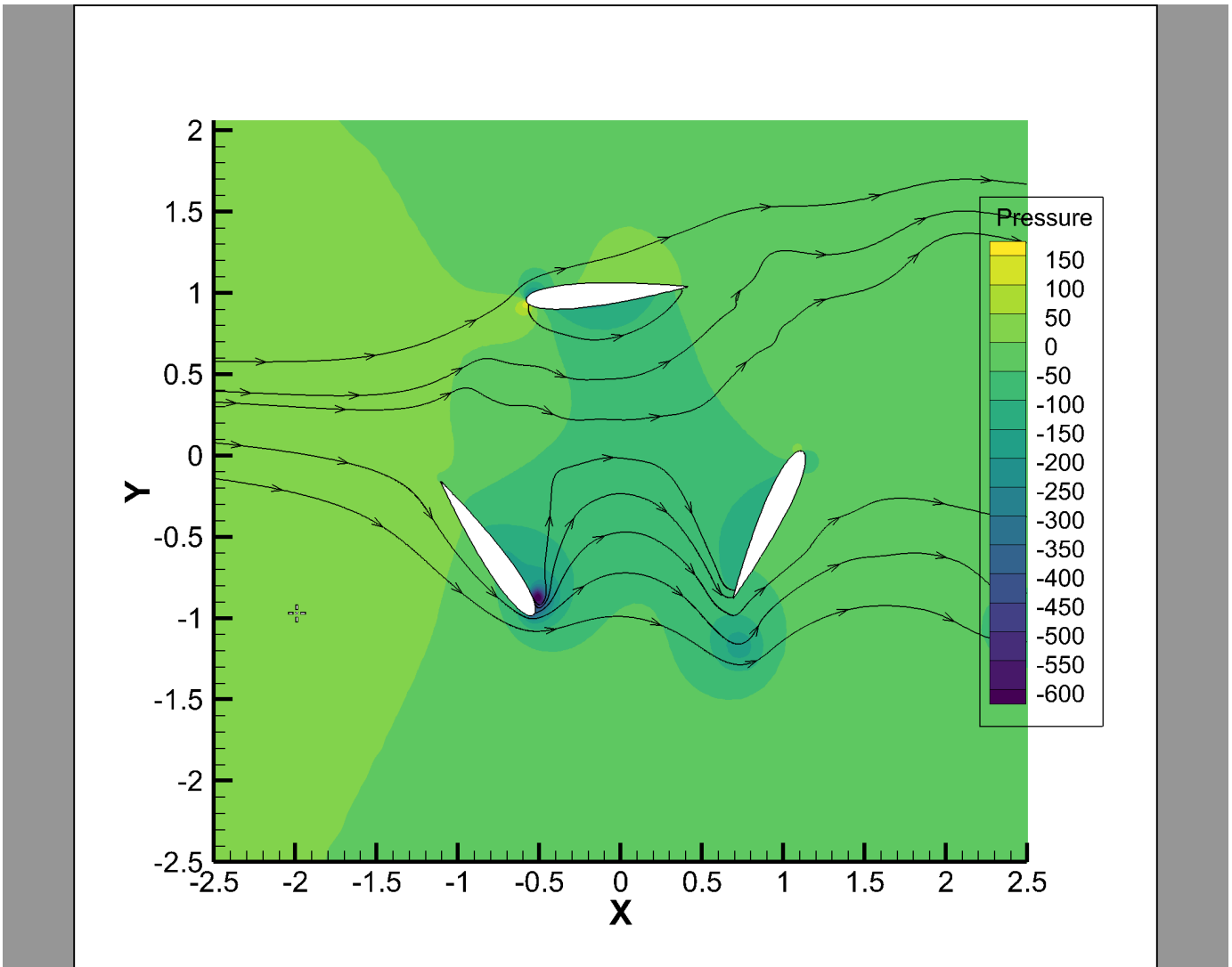

You may seed additional streamtraces by placing additional rakes in the same way, or seed individual points by clicking. A Tecplot 360 layout (.lay) file containing a snapshot of the final result of this tutorial segment is in [WindTurbineBlades/FinalLayouts/transient_1.lay](#) in the Getting Started bundle.

Step 7: Animate Your Plot

Click the **Play** button in the Plot sidebar to see how pressure and fluid flow change as the wind turbine blades rotate. (Just as we deduced earlier from the blade shape, the turbine turns counterclockwise.)

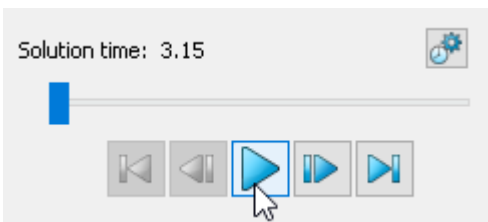

Scenic Detour: Animation Speed

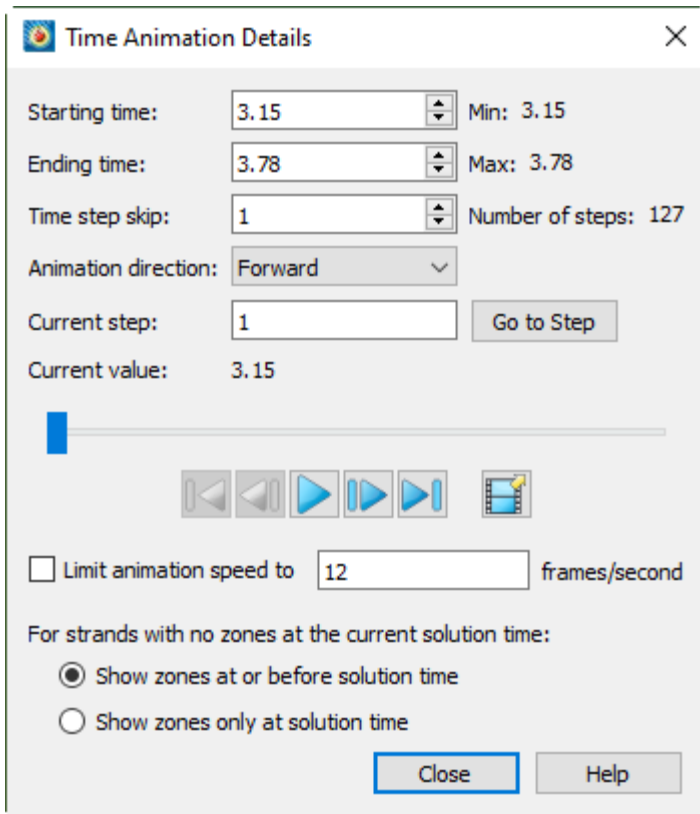

The animation speed can be limited in the Time Animation Details dialog, which can be reached by clicking the  button next to the animation controls in the Plot sidebar.

The maximum animation speed is limited by the speed at which Tecplot 360 can draw an individual frame, which depends a lot on how fast your computer is and how much of the data has already been loaded into memory. However, you can keep animations from going too fast by clicking the Limit Animation Speed checkbox and entering the desired number of frames per second.

Extracting Data

In this exercise, we will cover extraction techniques that helps you visualize details about your data at a particular location, allowing you to focus on exactly what you want to learn. First, we'll extract data at a single time step to a line plot. Then we'll extract data at a single point over time into a time series plot.

But before we get started, turn off the streamlines you added at the end of the last exercise by turning off the Streamtraces checkbox in the Plot sidebar and return to the first time step of the data. Your plot should look something like this again.

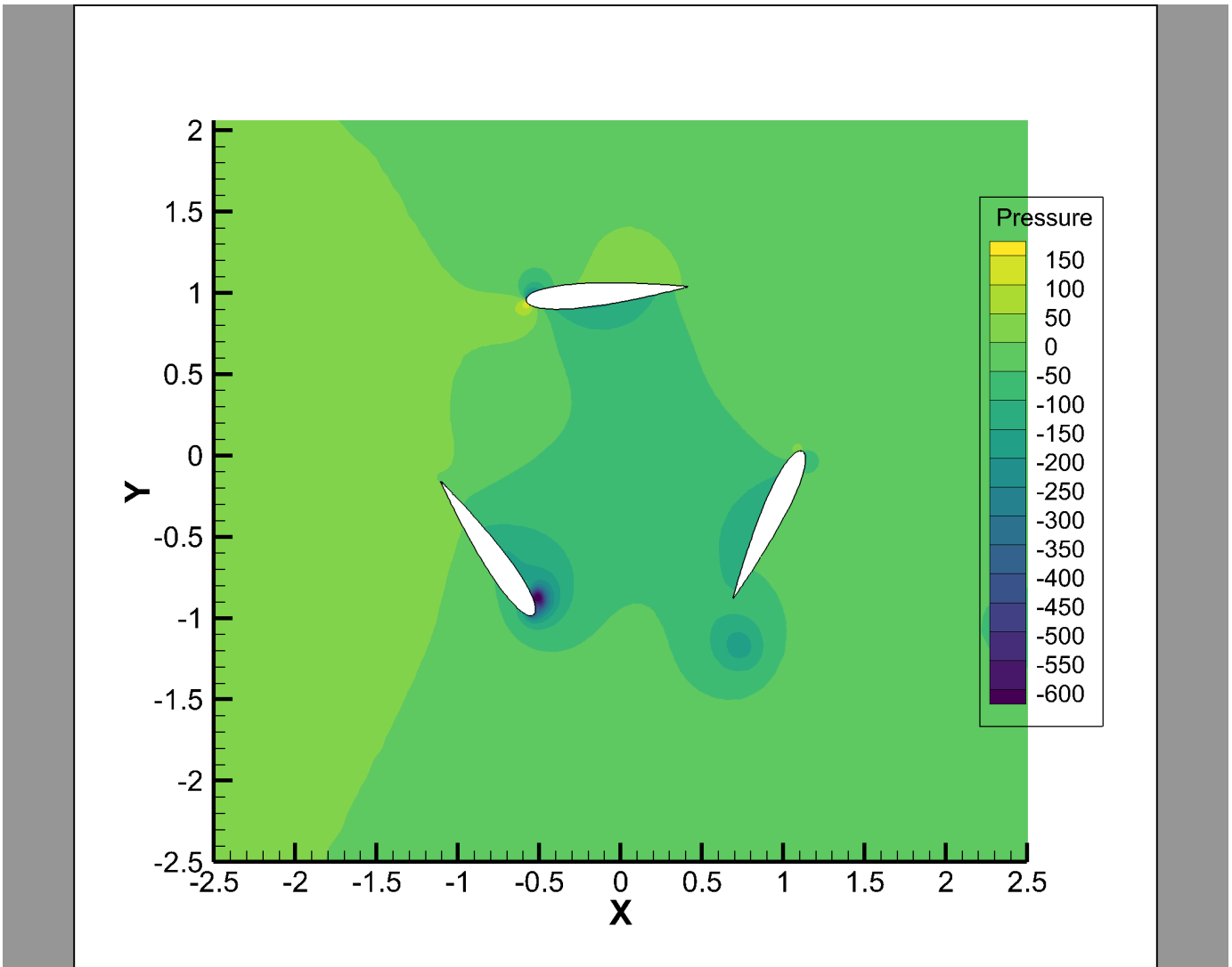

Save a layout at this point to make it easy to return this exact place for the next exercise.

Step 1: Create a Vertical Line

To draw the line along which we will extract the pressure data, first click the polyline geometry tool in the Tecplot 360 toolbar. A **geometry** is a shape that appears on your plot. This particular geometry tool can be used to create both lines and polygons, hence the name *polyline*.

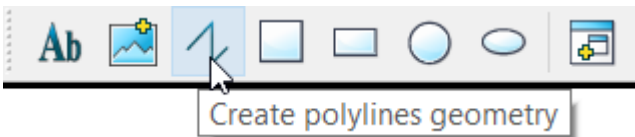

The line we want to draw is in roughly the same place as the rake we placed for creating streamtraces in the previous lesson. But the polyline tool, since it can be used to create both simple lines and more complex shapes, works differently from that tool.

To place the line:

- Click *and release* the mouse button with the pointer positioned just under the topmost blade of the

turbine. With the polyline tool, you don't drag the mouse with the button held down.

- Press the V key on the keyboard to constrain the line to vertical. Now you don't need to worry about making the line perfectly vertical; Tecplot 360 does that for you.
- Move the mouse down to the bottom of the green area. You will notice that a vertical black line follows the pointer. No matter how you move the mouse horizontally, the line stays put.
- *Double-click* the mouse to end the creation of the line. (If you had single-clicked, you would then be able to move the mouse and create an additional line segment attached to the first.)

The line should look roughly like this on the plot. We have made our line thicker so you can see it better. You don't have to do the same, but if you have a moment, see if you can figure out how.

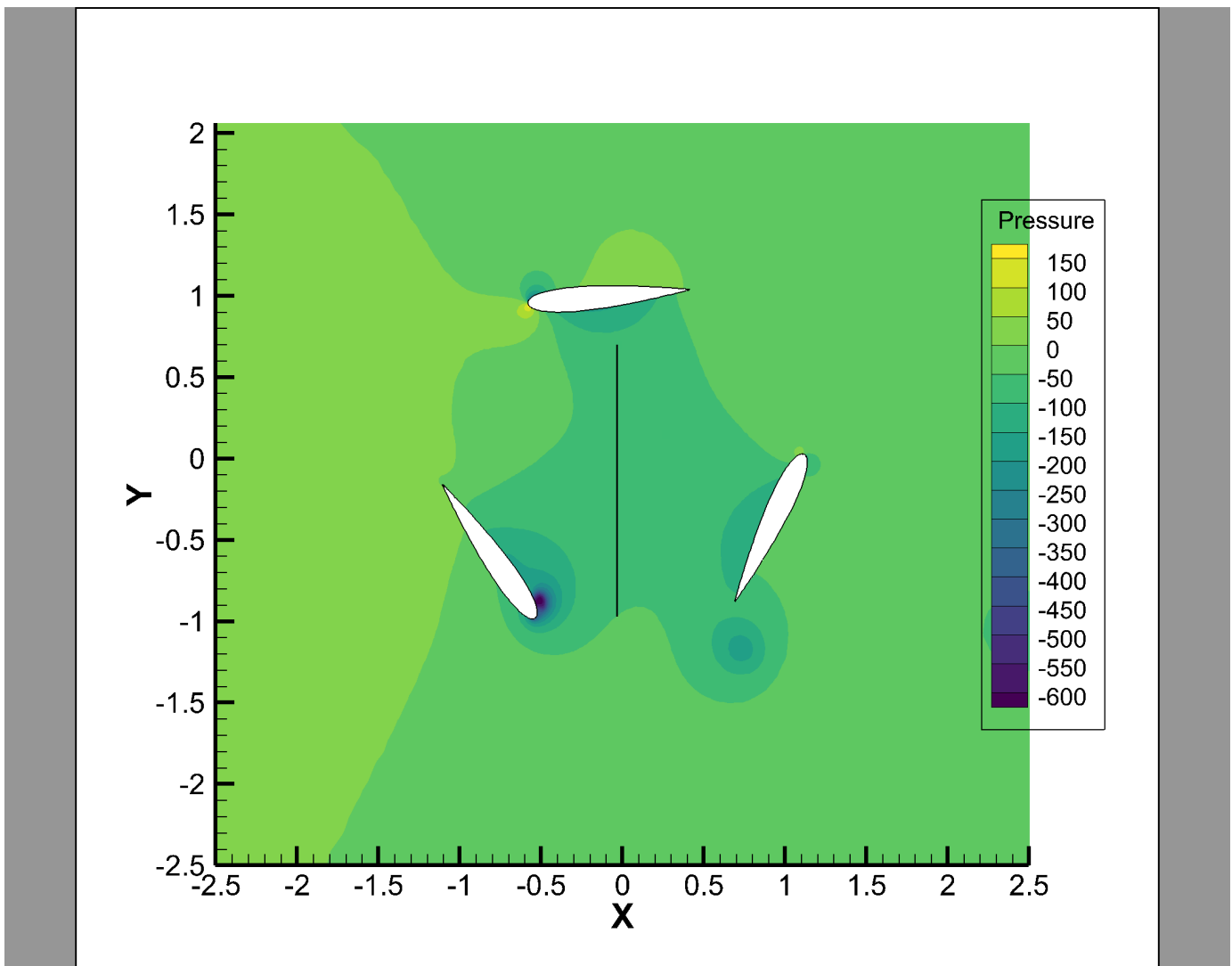

Step 2: Extract the Line Over Time

Let's see how pressure changes along our line *over time* by creating an animated plot of the Y coordinate vs. pressure. To do that, choose **Extract Polyline Over Time** from the **Extract** submenu of the **Data** menu.



If we were interested only in a single time-step, we could right-click the line and choose **Extract Points** from the context menu.

You will be asked for the number of points to be extracted along that line. The default value, which should be 100, is fine.

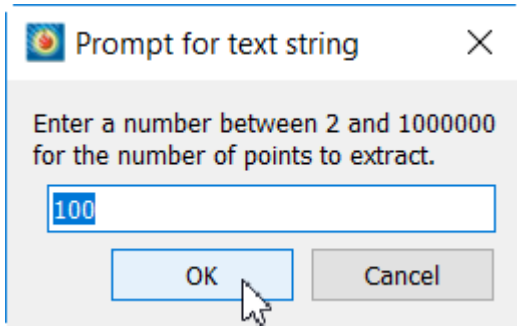

Tecplot 360 will take just a moment to go through all the time steps and extract the data along this line. You can open the Data Set Information dialog and see a new zone for each time step, named "Extracted Points," that were created beginning with zone number 1144 and ending with zone number 1270.

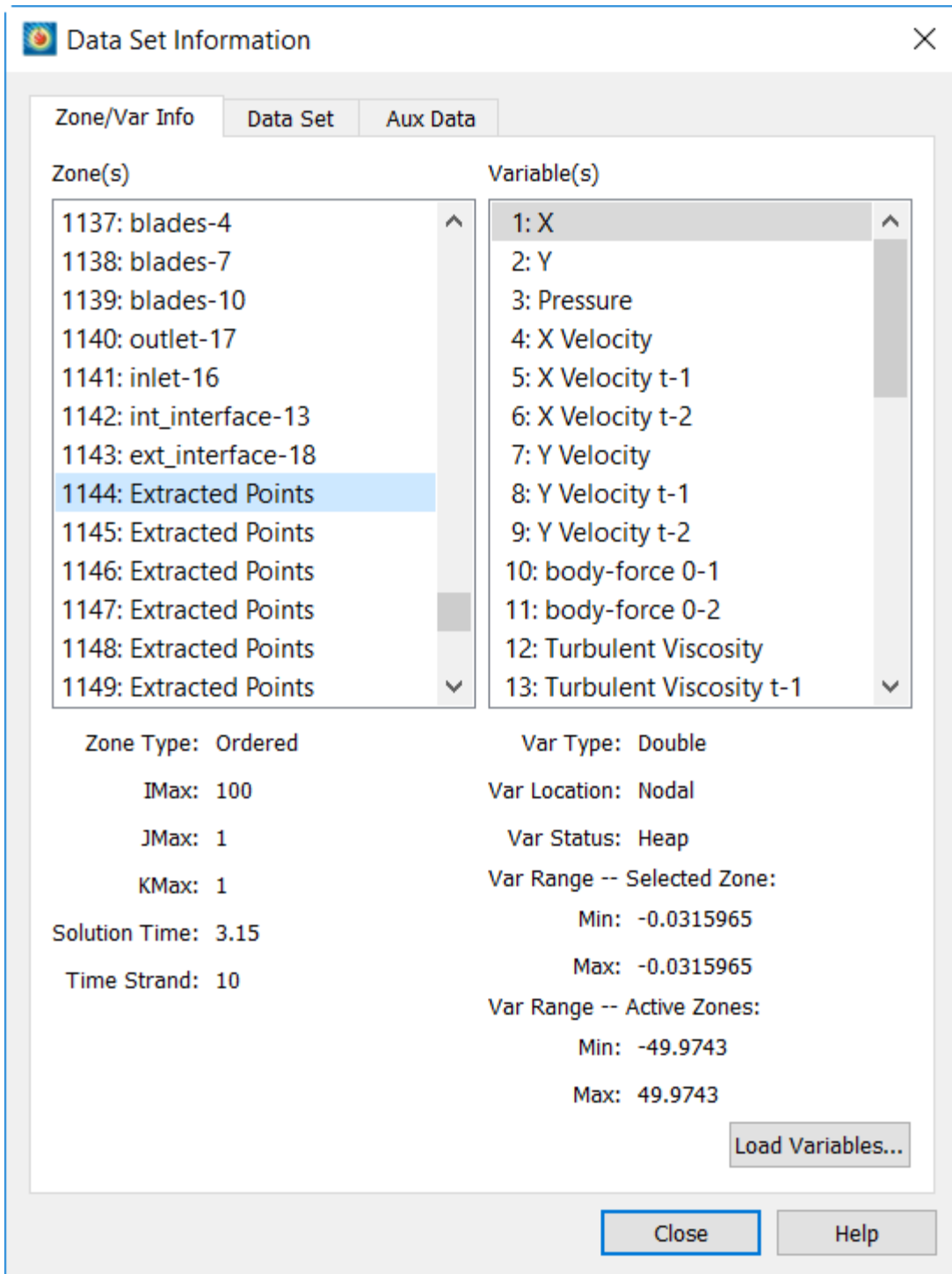

Each new zone is assigned the correct solution time and given a time strand to connect it to the others, just as we saw when we inspected the data in our file earlier.

That's 127 new zones in all, which matches the number of time steps in the file. All of these new zones are assigned to time strand 10, which makes sense because, previously, there were nine variables per time step and thus nine time strands. You can also see that each of the new zones has the same variable names as the previously-existing zones.

So, as we expect, we have extracted the data along the line over time.

Step 3: Create A Line Plot of Pressure

Let's see what the pressure looks like along our extraction line by creating a line plot. We can display this line plot side-by-side with the contour plot and even animate them together.

First, choose the New Frame tool in the Tecplot 360 toolbar. Then hold the mouse button down and drag out a rectangle on the plot. It doesn't matter where; we will resize and reposition it in the next step.



Your new frame might look something like this.

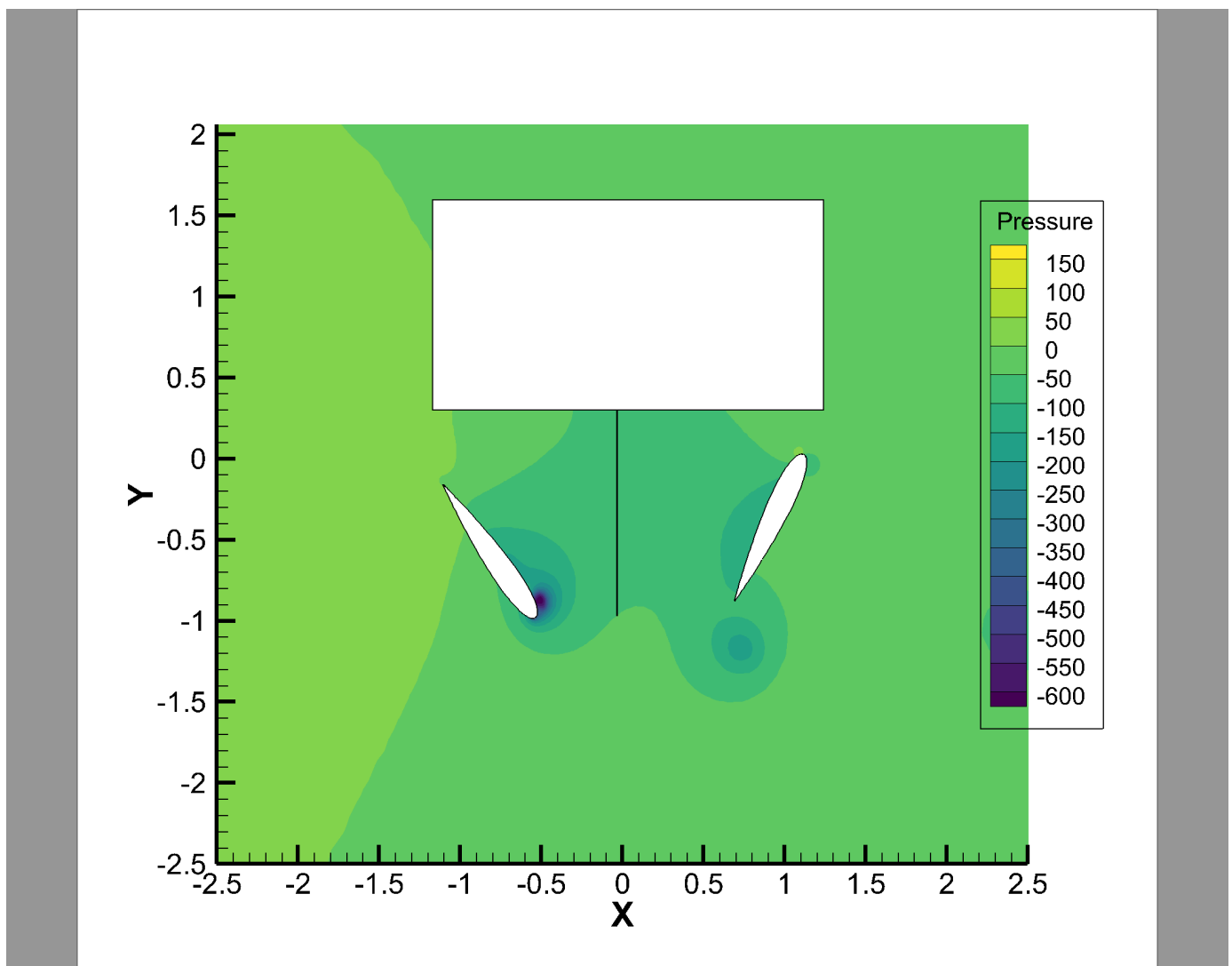

Let's get that new frame into position. Choose **Tile Frames** from the **Frame** menu, then click the bottom-right button.

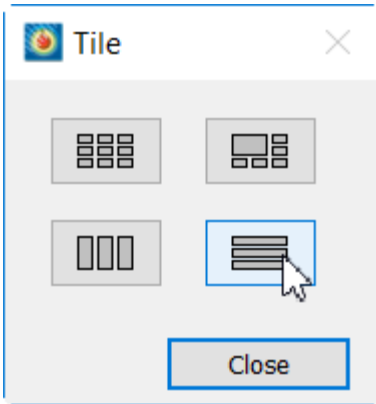

This will stretch both frames to the width of the workspace and position them one above the other, as seen here.

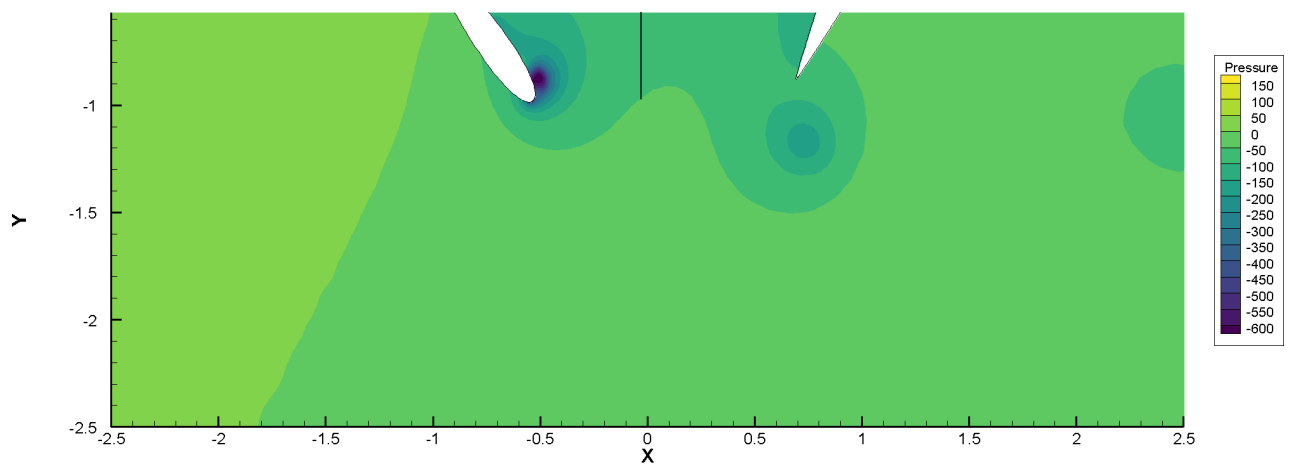

Let's go ahead and zoom out that top frame a bit and reposition it so that we can see the whole wind turbine. To do this, we will use the Zoom and Translate tools in the toolbar.

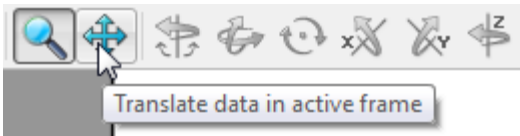

- Choose the Translate tool and drag the plot in the top frame so that it is centered
- Choose the Zoom tool, then hold down the Control key while clicking the plot to zoom out one step.

The top frame should look more like this now.

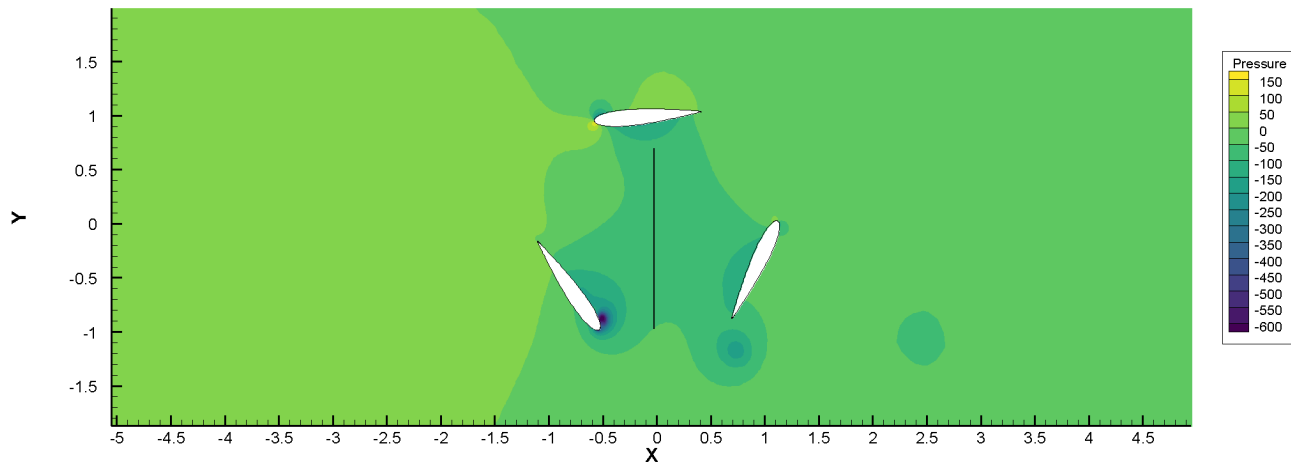

Now we'll turn our attention to the bottom frame, where we'll create a line plot of pressure along the line we placed on the plot earlier.

- Choose the selector (arrow) tool from the Tecplot 360 toolbar and click the bottom frame to select it.
- Change the plot mode to 2D Cartesian using the menu at the top of the Plot sidebar.

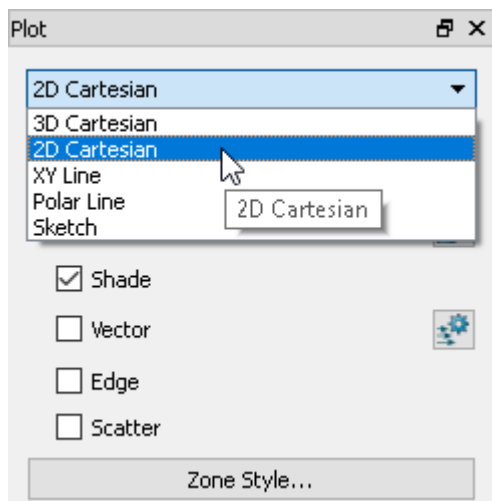

You might think to use an XY Line plot for this kind of data, and normally you could, but XY Line plots don't have the transient capabilities of 2D Cartesian plots.

In the bottom frame, you'll see a gray circle very similar to the plot that appeared when we first

opened this data set.

- Use the Zone Style dialog to turn off all zones except for the Extracted Points zone. Click the **Zone Style** button in the Plot sidebar, then right-click in the Show Zone column of the last zone listed and choose **Show Selected Only**.

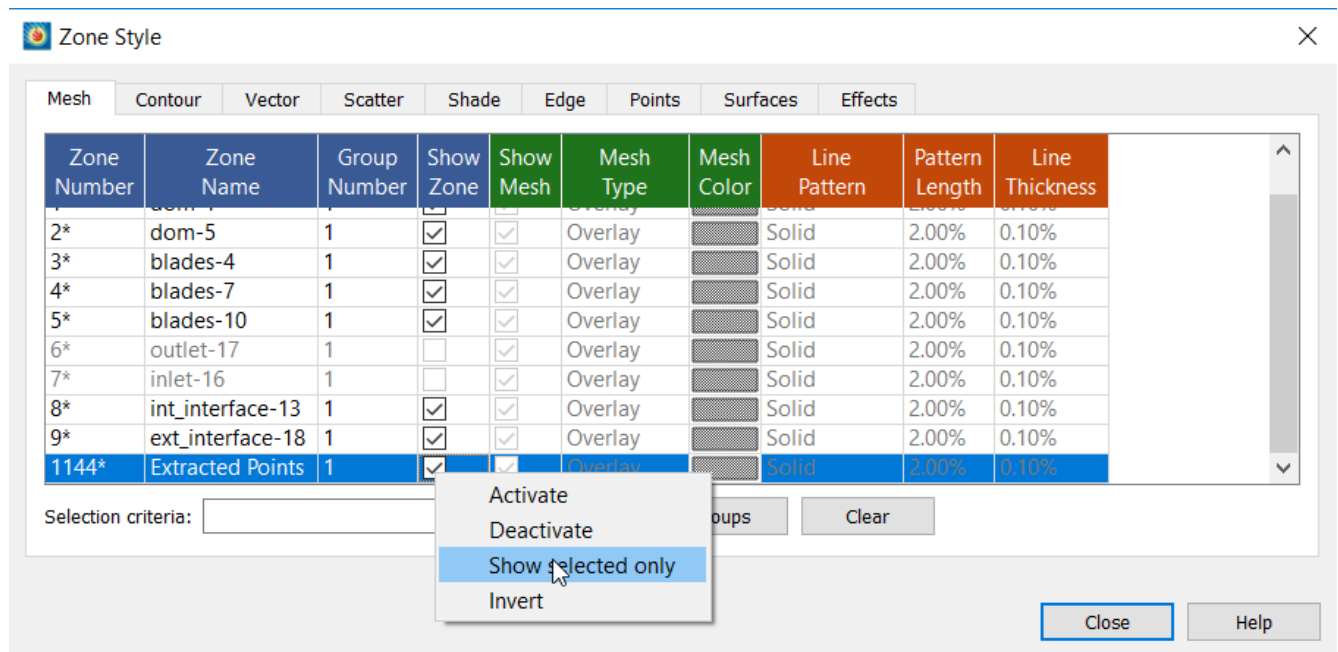

Note that this zone has an asterisk by its number, indicating that it has a time strand, as we have previously seen in the Data Set Information dialog. Thus, when we make only this zone visible, it is the only zone visible at all time steps.

Close the Zone Style dialog after doing this.

- To assign variables to the axes, choose **Assign XY** from the **Plot** menu, then selecting the Y and Pressure variables for the X and Y axes as shown here.

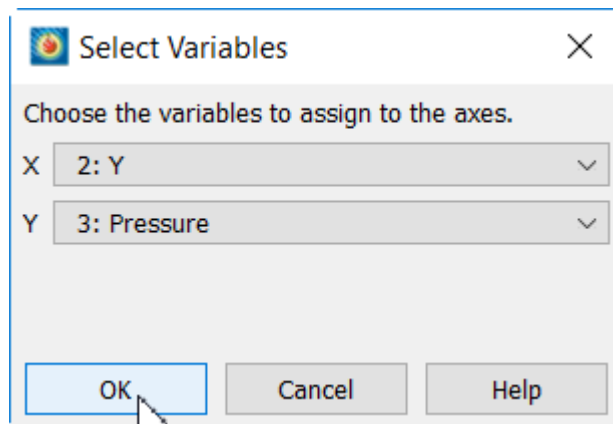

Your line plot still looks very blank at the moment.

- Activate the Mesh checkbox in the Plot sidebar to see the line.

It's all scrunched up along the left side of the plot because the axes aren't set up properly. We'll take care of that next.

- Choose **Axis** from the **Plot** menu to open the Axis Details dialog. Change the Dependency radio button for the X axis to Independent, as shown here.

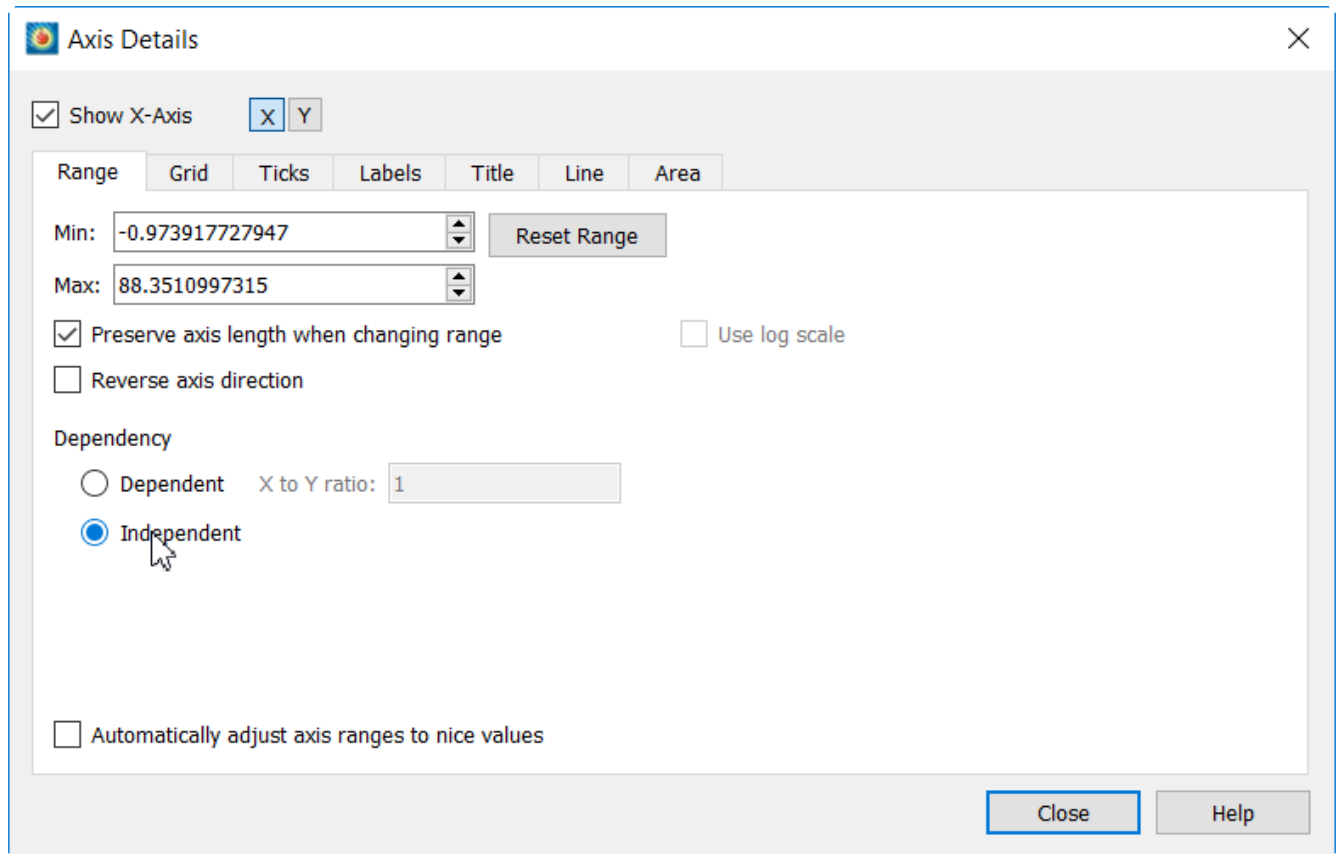

We'll let Tecplot 360 choose the range for the axis. Leaving the Axis Details dialog open, choose **Data Fit** from the **View** menu in the main Tecplot 360 window. (You can also just press Control-F.)

- The Data Fit operation also set a range for the Y axis, but it did so only considering the Y-axis range of the first time step. The range of Pressure at the first time step is not representative of all time steps, so we will manually specify an appropriate Y-axis range.

Change to the Y axis using the button at the top of the Axis Details dialog, then enter -100 and -30 as the minimum and maximum.

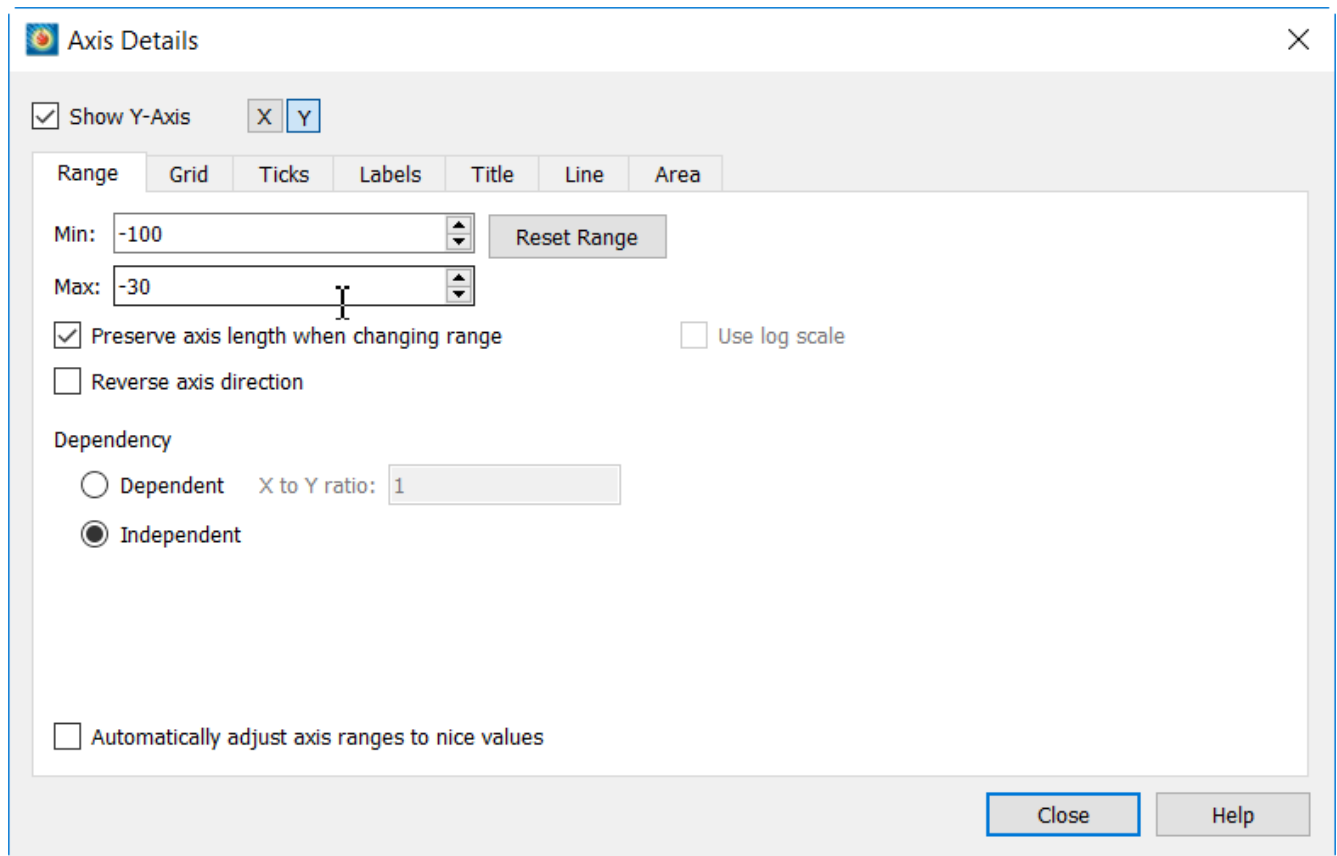

- Close the Axis Details dialog.

The plot in the bottom frame should now look a lot like this.

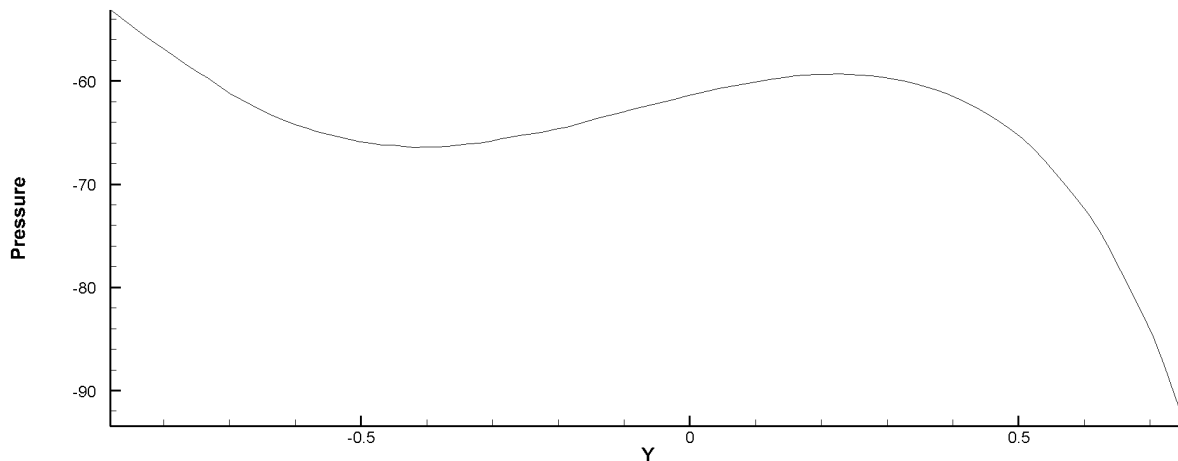

Step 4: Link the Time Steps and Animate the Plot

If you try animating the plot by pressing the **Play** button on the Plot sidebar, you will notice that only the active frame animates. To get both frames animating together, we will link them so they always display the same time step.

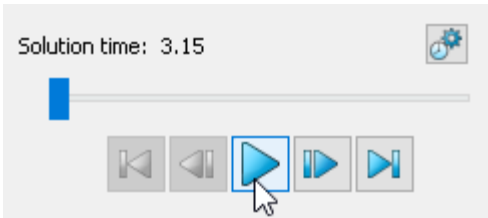

To do this, choose **Frame Linking** from the **Frame** menu to open the Set Links for Active Frame dialog.

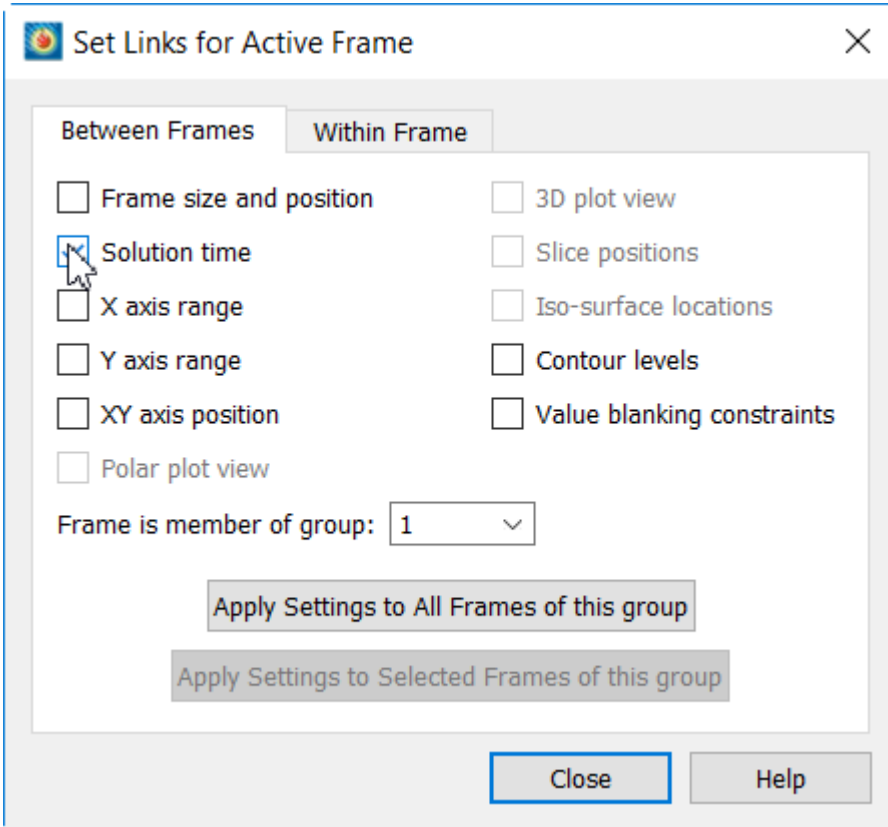

On the Between Frames page, mark the Solution Time checkbox, then click the **Apply Settings to All Frames of this Group** button. Close the dialog and try animating again!

Scenic Detour: Add Solution Time Caption

It would be nice to be able to see what the solution time is right on the plot, without having to look at the Plot sidebar. This might be of particular utility if you were exporting a video. To do this:

- Click the Add Text tool in the Tecplot 360 toolbar.

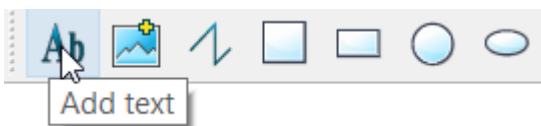

- Click on the plot where you want the text to appear.

This displays the Text Details dialog, where you can enter text and choose its formatting.

- In the Text Details dialog, enter `Solution Time: &(SOLUTIONTIME)`

The text starting with an ampersand is a dynamic text placeholder. Tecplot 360 replaces it with the current solution time when displaying it in the plot.

Solution Time: 3.15

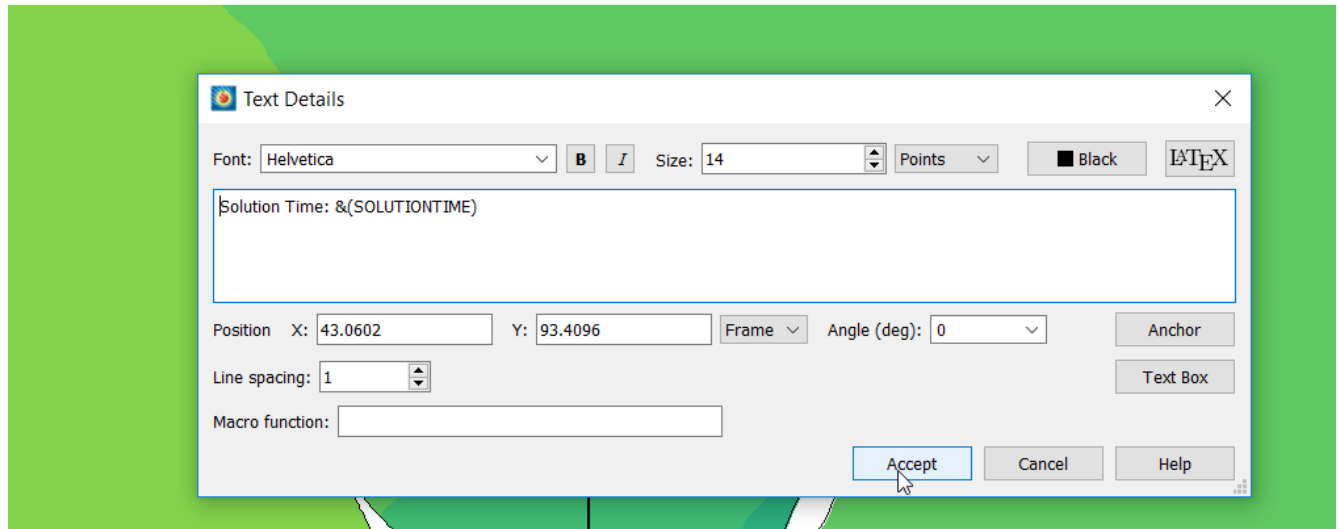

- Click **Accept** to close the Text Details dialog.

Animate again and watch the solution time change!

Step 5: Time Series Plot

We have seen how to create a line plot showing the pressure along a line at each time step. Using animation, we can show how that changes over time. Now we'll reduce the dimensionality even further by creating a single line plot showing how pressure varies at a single point.

To create this time series plot, choose **Probe to Create Time Series Plot** from the **Tools** menu, then click as close to 0, 0 as you can get on the contour plot (top frame). Hint: the X and Y coordinates of the mouse cursor are displayed in the bottom right corner of the Tecplot 360 workspace.

After you click, Tecplot 360 spends a moment gathering the pressure value for that point for all time steps, then displays the time series plot in a new frame overlapping the contour plot.

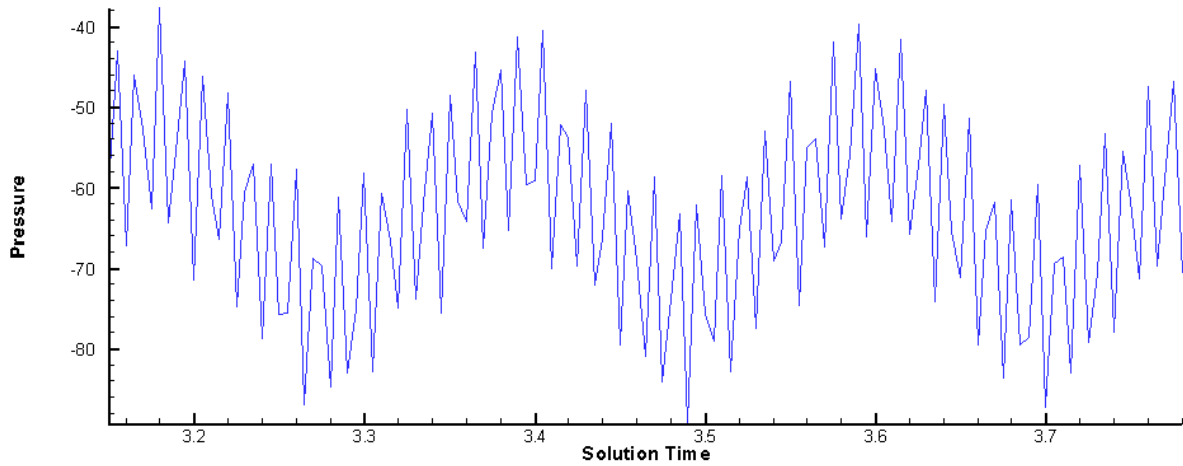

When you animate, a moving vertical line appears in this plot to indicate the current time step.

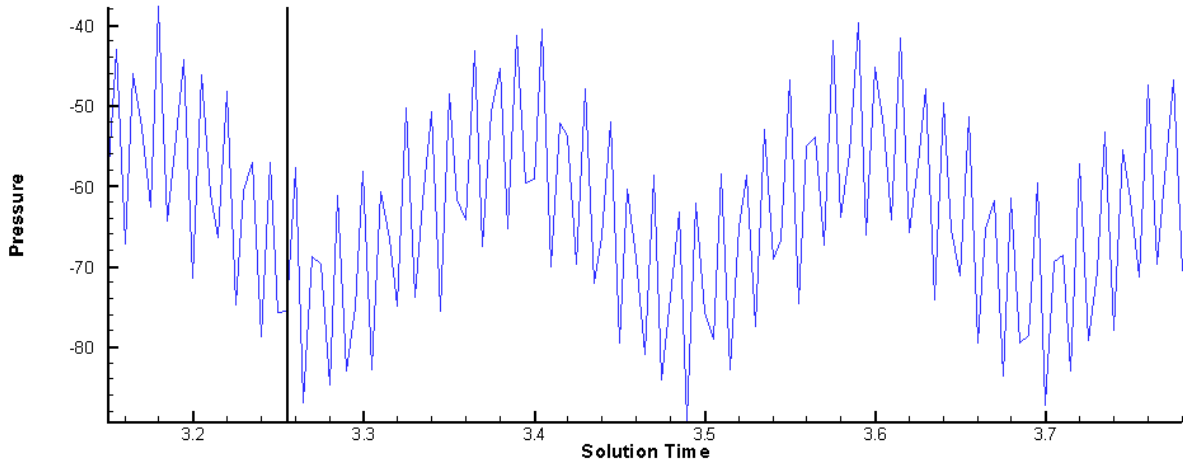

All three plots (the contour plot, the pressure line plot, and the time series plot) animate at the same time.

Try using the Tile Frames tool we used earlier to find a good arrangement for your three frames. You'll probably need to re-position and zoom out on the contour plot again.

Solution Time: 3.605

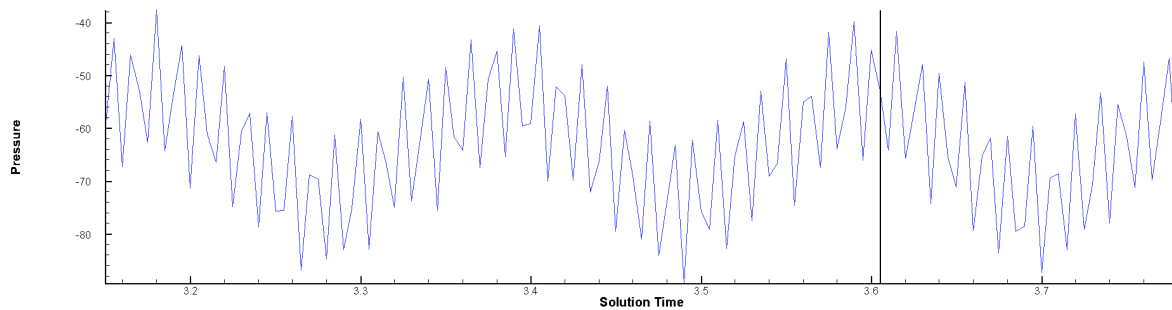
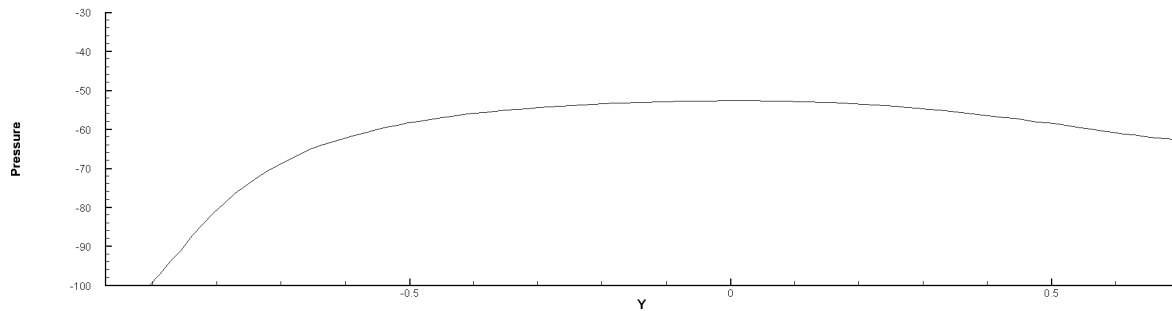
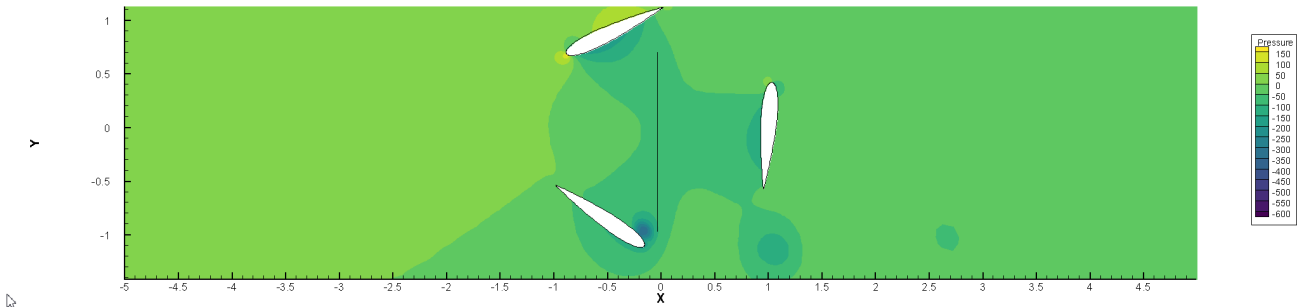

Frequency Analysis Using Fourier Transform

As we can see from the time series plot we just created, pressure varies over time and appears to do so as a wave. In this exercise, we'll analyze the fundamental frequency of the pressure waves in the data using a Fourier transform, and see how this varies when changing the probe location.

Before starting, let's delete the middle frame (which shows the pressure along the line). First, choose the selector tool in the toolbar, if it isn't already selected.

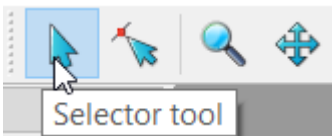

Then click the edge of the middle frame to select it, then press the Delete key on your keyboard.

Finally, re-tile the frames by choosing **Tile Frames** from the **Frame** menu. You may want to zoom in on the contour plot and/or re-center it. The plot should look something like this.

Solution Time: 3.15

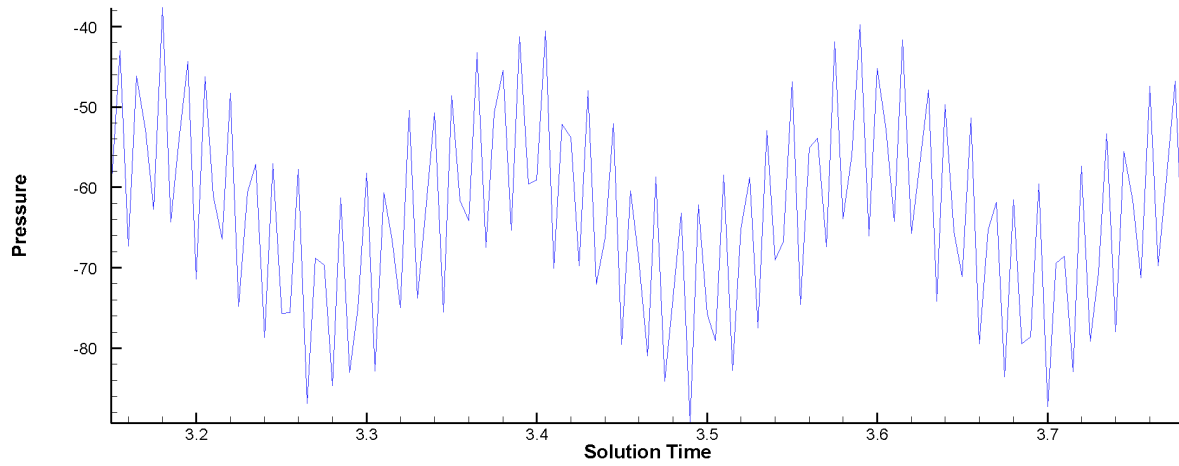
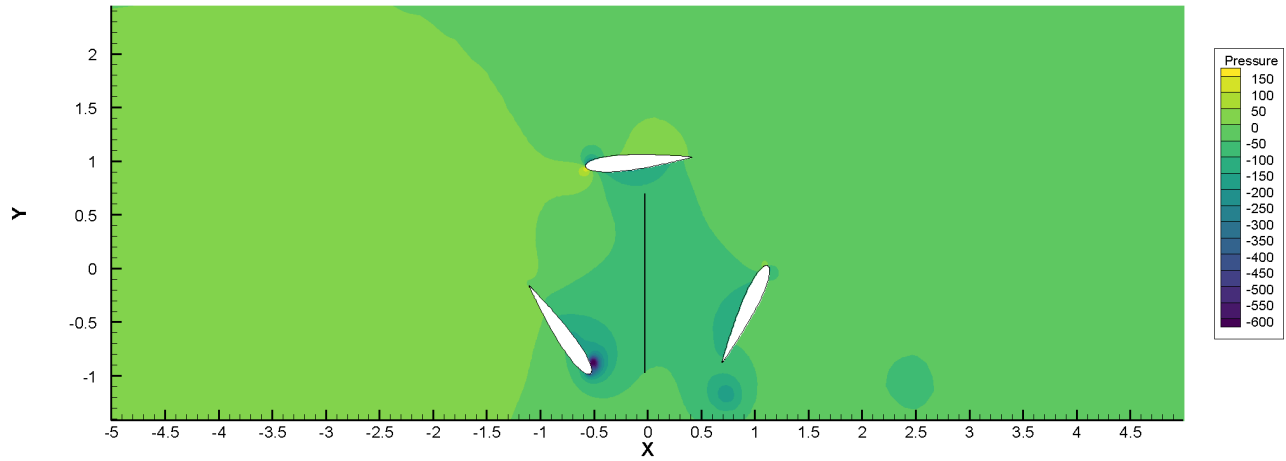

Step 1: Fourier Transform

Select the bottom frame (containing the time series plot) with the selector (arrow) tool, then choose **Fourier Transform** from the **Data** menu. The Discrete Fourier Transform dialog, shown here, appears.

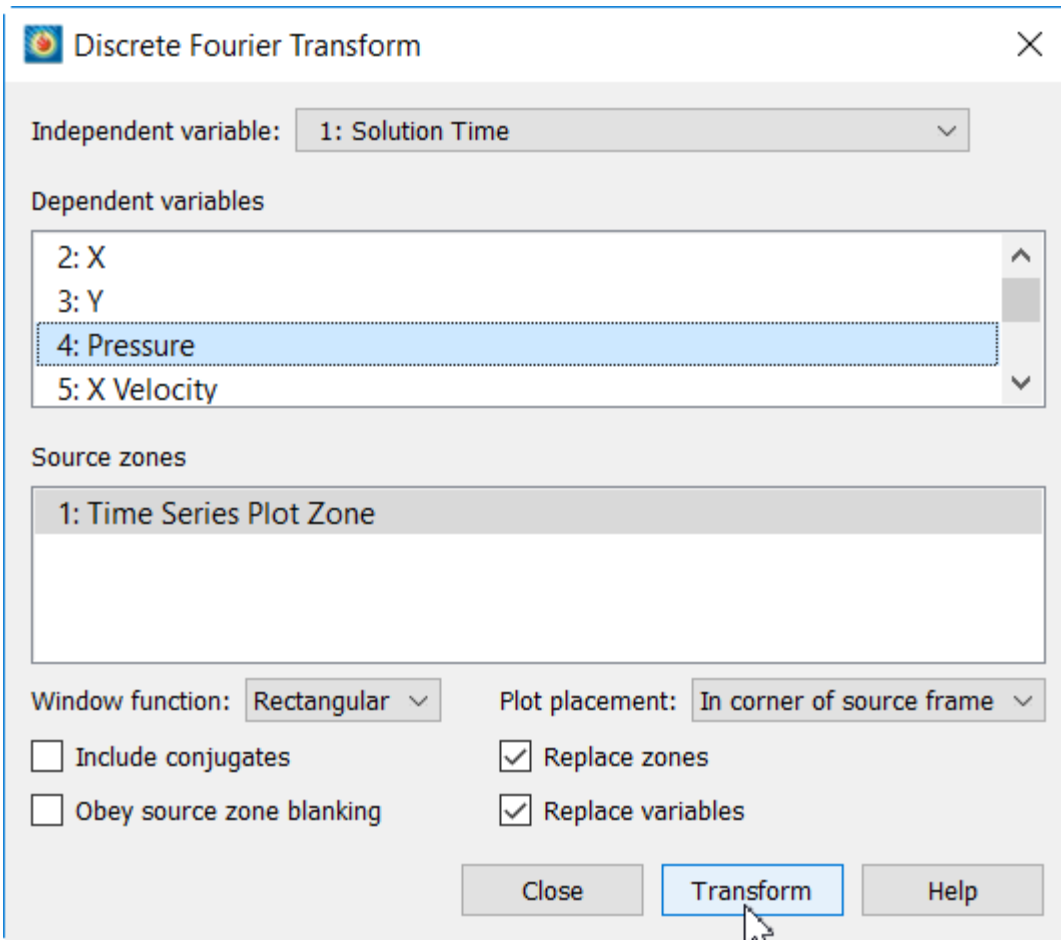

In this dialog, choose Pressure as the dependent variable and make sure the Time Series Plot Zone is selected as the source zone. Using the **Plot Placement** drop-down menu, choose to tile the new frame with existing frames. Leave everything else the same. Click **Transform** to perform the Fourier transform.

A new frame appears, showing Frequency (Solution Time)⁻¹ on the X axis and Amplitude (Pressure) on the Y axis.

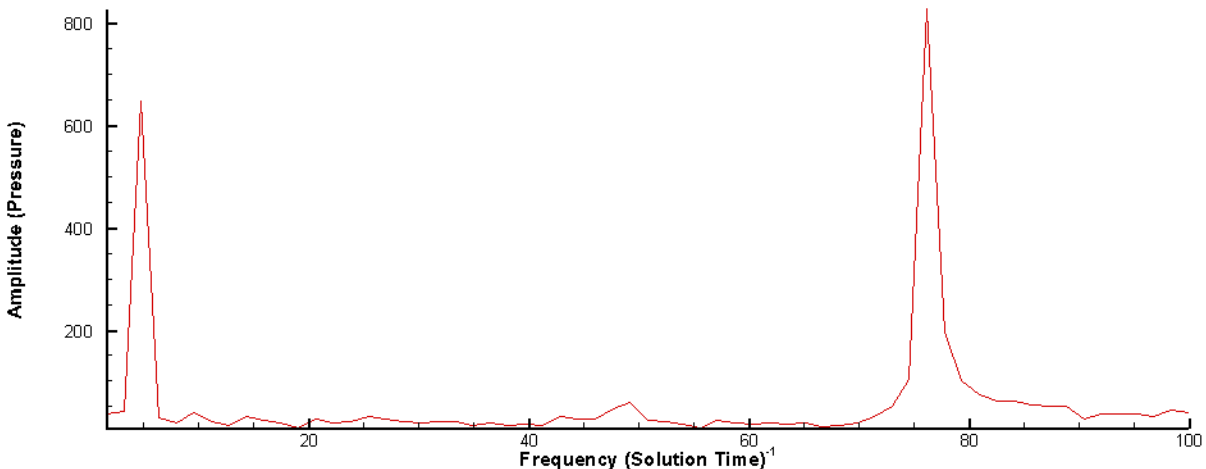

Looking at this plot, we can easily see that there is a low-frequency spike at around 5 Hz and a higher-frequency spike at about 77 Hz. This matches what we see in the time series plot: a lower-frequency (high-period) wave overlaid by a higher-frequency (low-period) wave. The combination makes the time series plot look a little jagged.

From watching the animation, we can attribute the lower-frequency pressure changes to the movement of the blades. However, we don't have an obvious explanation for the higher-frequency changes.

Before going further, let's have a quick look at what the Fourier Transform actually did to our data set by popping into Data Set Information (choose **Data Set Info** from the **Data** menu). Make sure that the Fourier plot frame is selected.

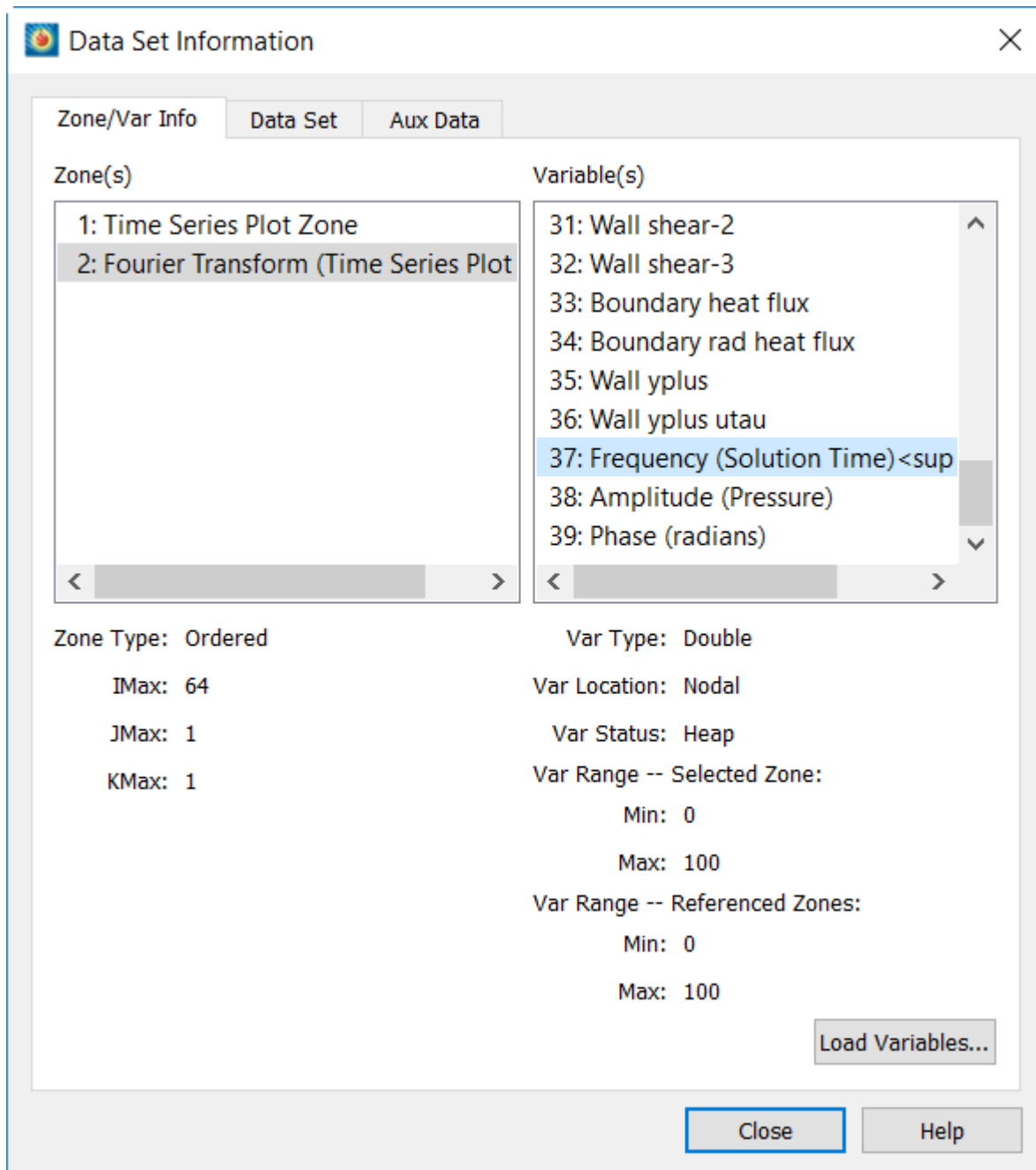

As you can see, Tecplot 360 has created a new Fourier Transform zone based on the Time Series Plot and added three new variables starting with variable 37. (The other zone and the first 36 variables were created when we generated the time series plot.)

The new variables are the frequency, amplitude, and phase output from the Fourier transform. We only selected Pressure as our dependent variable in the transform, but if we had selected more, there would be three new variables for each one we selected.

Step 2: Re-Analyzing at a New Position

Let's see if we can find out what's causing the higher-frequency changes. To do this, we'll re-probe well outside the turbine, near the left inlet. Then we'll create a new time series plot and re-do the Fourier transform.

Zoom out the contour plot so that you see most or all of the fluid domain surrounding the turbine. The blades will be very small in the center of the plot. At right you'll see we've zoomed all the way out. The mouse pointer is placed roughly where we'll be probing.

Solution Time: 3.15



Now choose **Probe to Create Time Series Plot** from the **Tools** menu again, and click close to the indicated position on the plot. A new time series plot is created.

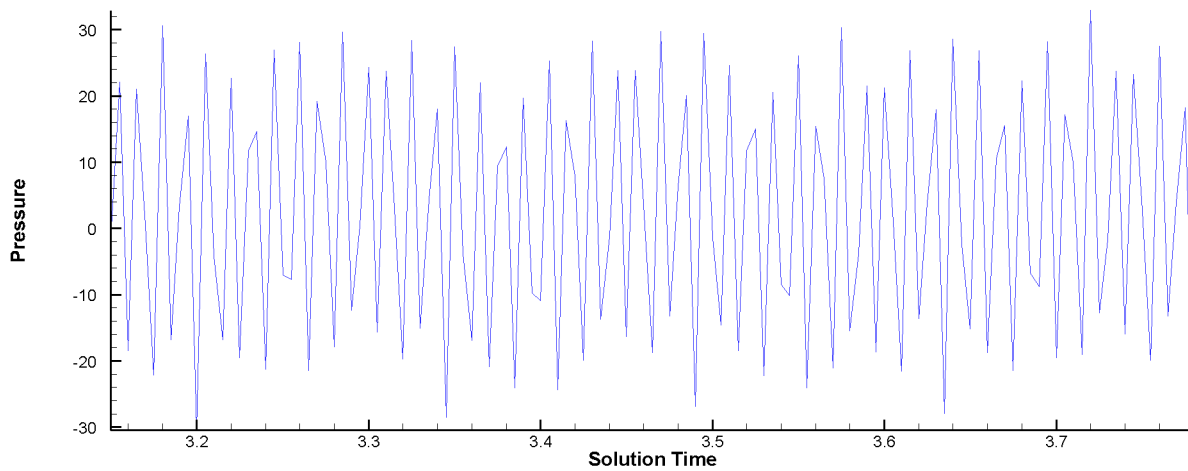

Right away, you can see that this plot has less obvious order in it.

Since our Fourier transform plot was calculated from the data in the old time series plot, it disappears. But we can re-create it easily. Simply right-click the line in the time series plot to display the context menu and toolbar. Then choose **Fourier Transform** from the menu.

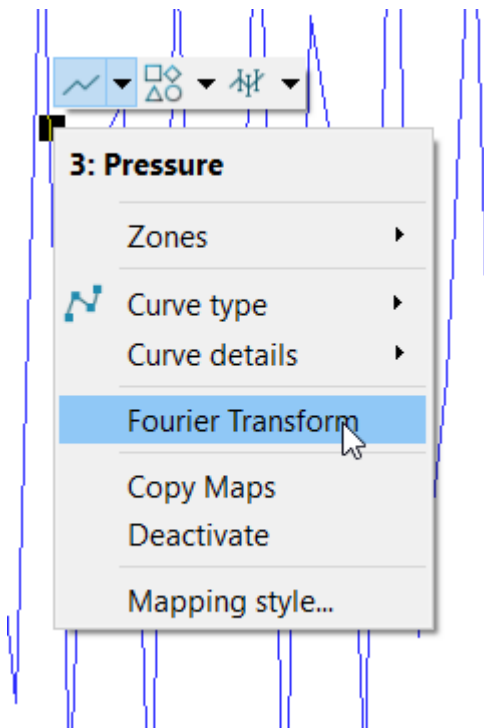

A new Fourier transform plot is created using the options previously set in the Discrete Fourier Transform dialog. It looks something like the plot below.

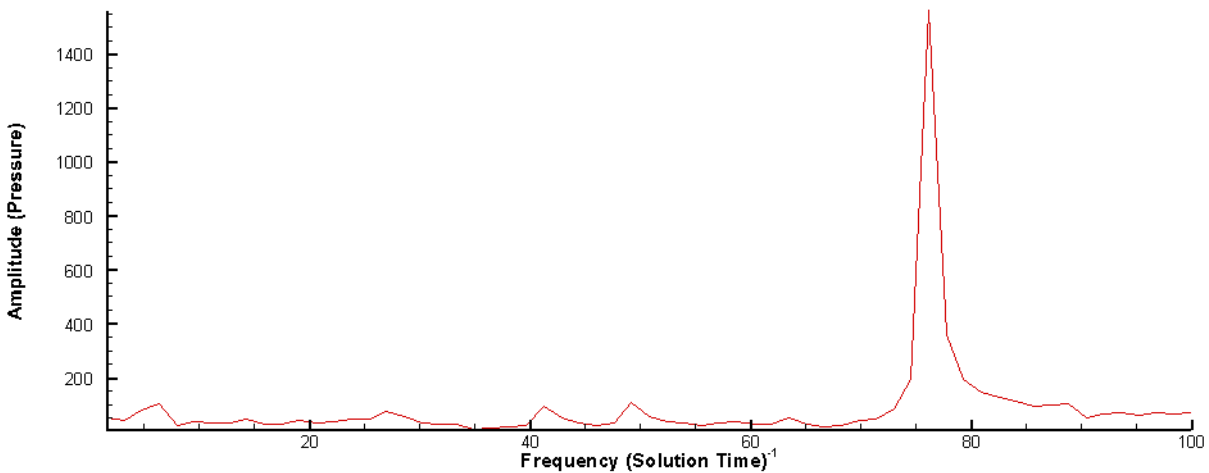

Here, the main frequency is the one we previously saw at around 77 Hz. The lower frequency around 5 Hz is no longer there, indicating that we are probing far enough away to avoid the effects of the turbine blades. We can conclude that the 77 Hz frequency is an input boundary condition.

A Tecplot 360 layout (.lay) file containing a snapshot of the final result of this tutorial segment is in [WindTurbineBlades/FinalLayouts/transient_2.lay](#) in the Getting Started bundle.

Your Turn

Try analyzing other variables, such as Turbulent Viscosity. By probing near where vortices are shed, you can see how changes in turbulent viscosity are solely due to the motion of the turbine blades. We will delve into this in more detail in the next exercise.

Calculations and Contour Cutoff

Tecplot 360's CFD analysis tools have many tricks up their sleeve. One of the most important is the ability to calculate commonly-needed variables that are not actually present in the data set. Why have your solver calculate, say, vorticity magnitude (and expend disk space storing these values) when it can be easily derived from values already in the data set?

Furthermore, Tecplot 360 can calculate these values on demand, so no time is spent on calculating them unless and until we choose to visualize them. This means that until we use vorticity magnitude in a plot, it does not need to be calculated at all. And even when the variable is being used in a plot, it will not be calculated for a given time step until we actually view that time step. (Once calculated, however, the value remains in memory, so returning to a time step usually won't require it to be calculated a second time.) So, if we will be looking at only ten or fifteen time steps in our data set, using calculate-on-demand will save us around 90% of the time we might have spent calculating vorticity magnitude.

In this exercise, we'll calculate Vorticity Magnitude using the Tecplot 360 CFD analysis tools. Then we'll adjust the contour color cutoff to isolate interesting regions of the plot.

We'll only need the contour plot for this exercise. You can delete the frames containing the time series

and Fourier plots you created in the previous exercise and re-tile so that the contour plot frame fills the workspace. Re-zoom and re-center as needed.

Step 1: Set Field Variables

Before we can calculate the new variable, we must make sure that the baseline variables are assigned in the Field Variables dialog. To open this dialog, choose **Field Variables** from the **Analyze** menu.

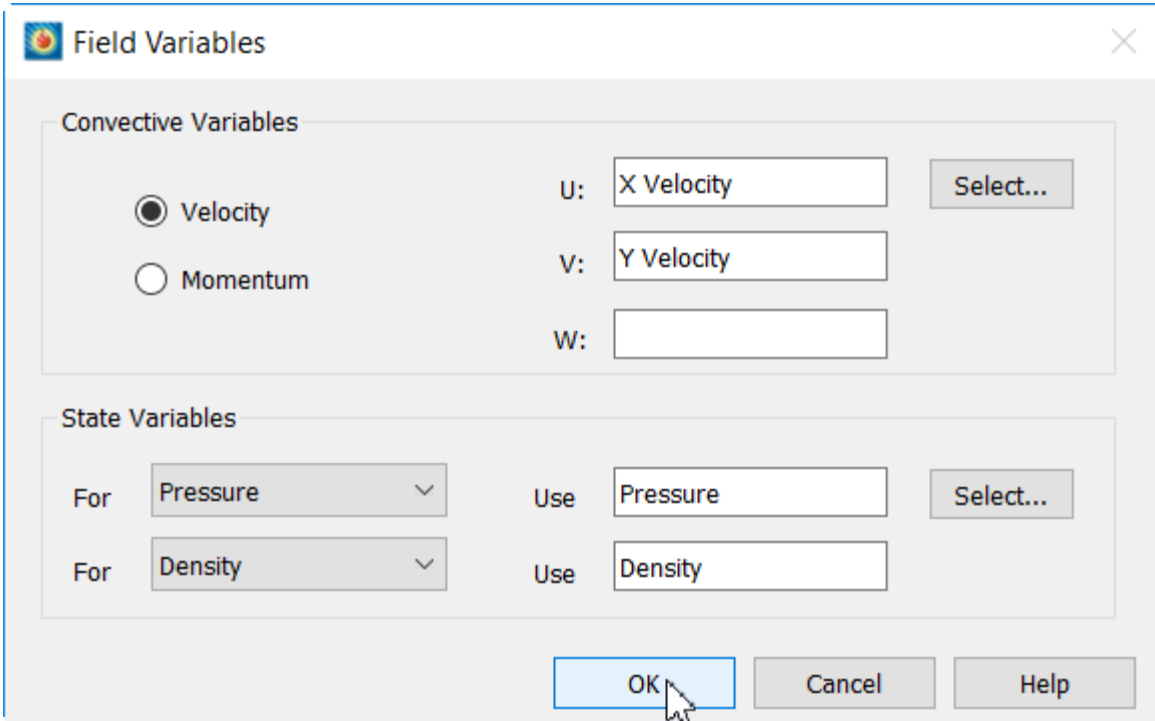

Tecplot 360 has chosen defaults that match what it thinks you want to do:

- X Velocity and Y Velocity have been chosen as the convective variables U and V.
- Pressure and Density have been chosen as the corresponding state variables.

For this data set, these defaults are correct, so you can just click **OK**. For other data sets, you may need to choose different variables.

Step 2: Calculate Vorticity Magnitude

To calculate vorticity magnitude, just choose **Calculate Variables** from the **Analyze** menu. This displays the Calculate dialog.

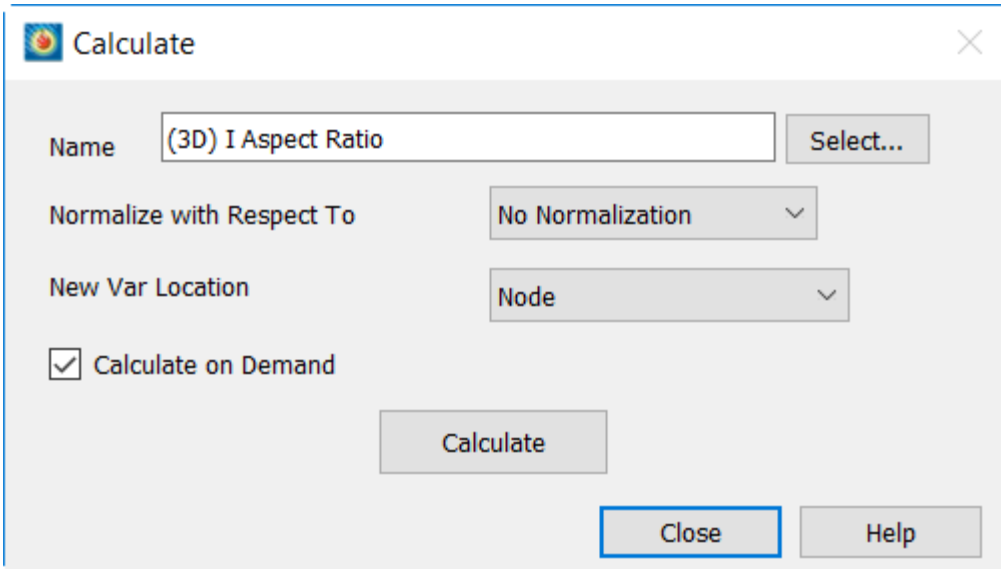

Click the **Select** button to choose the variable to be calculated. This displays the Select Function dialog.

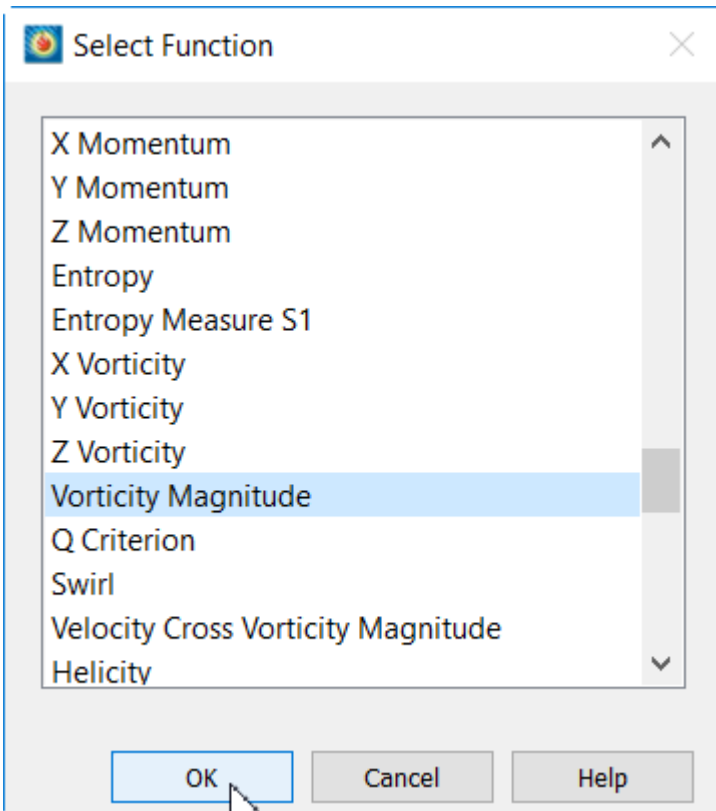

As you can see, there are literally dozens of variables that Tecplot 360 can calculate for you. Choose Vorticity Magnitude in the list then click **OK** to return to the Calculate dialog. The default options in the Calculate dialog are acceptable (note that the Calculate on Demand checkbox is checked!) so go ahead and click **Calculate**.

Tecplot 360 sets up calculate-on-demand for Vorticity Magnitude and adds the variable to the data set, and tells us that's what it has done via an alert.

We can now close the Calculate dialog.

Step 3: Show Vorticity Magnitude on Contour Plot

To actually show our newly-calculated variable on our plot, open the Contour Details dialog by clicking the  button next to the Contours checkbox in the Plot sidebar.

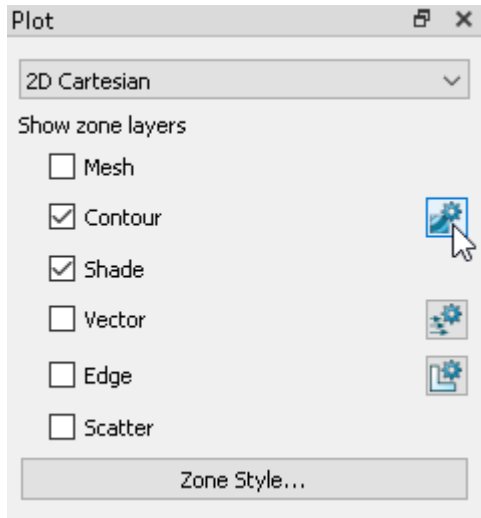

The Contour Details dialog appears.

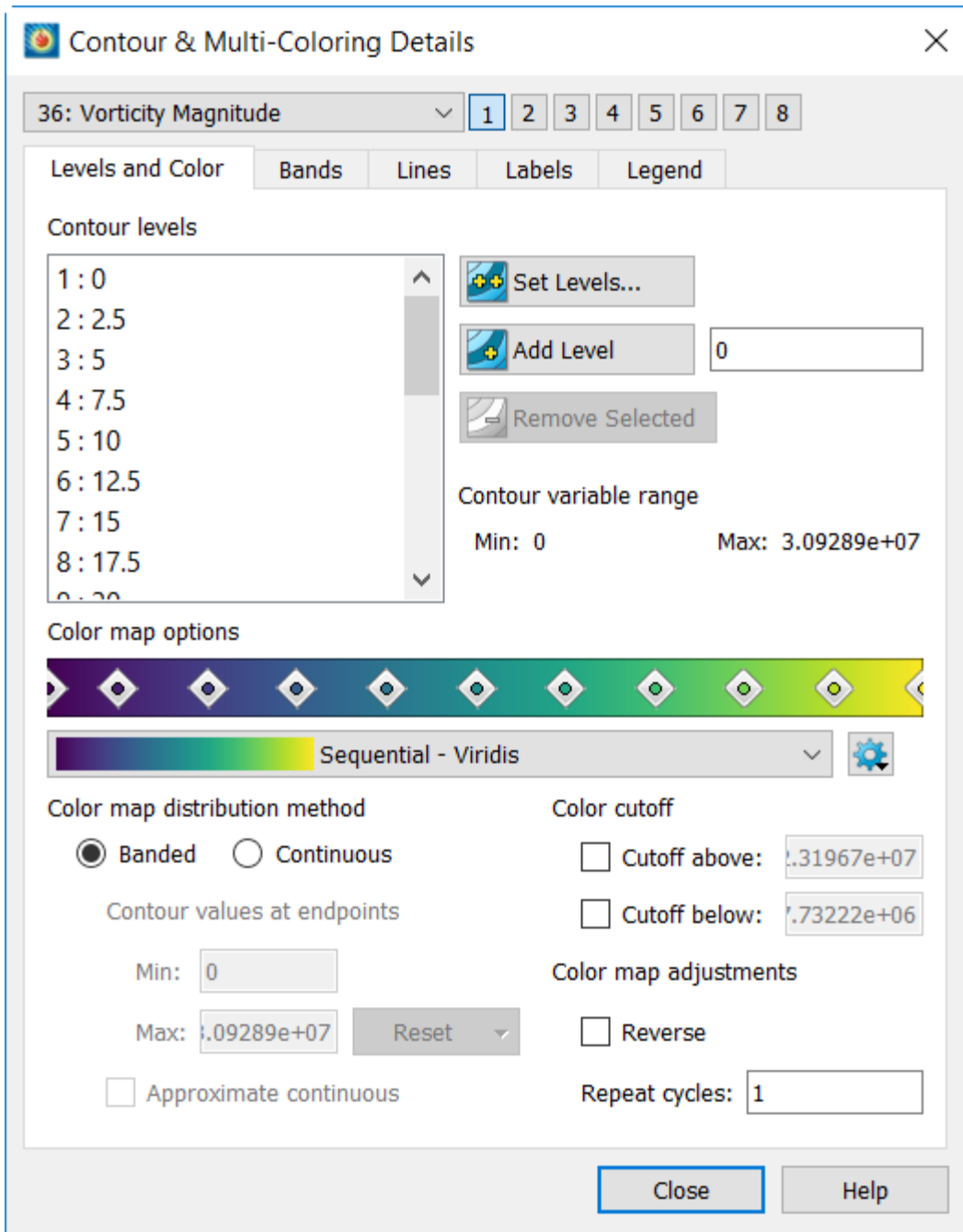

In the Contour Details dialog:

- Choose **Vorticity Magnitude** from the menu at the top of the dialog.
- Click the **Set Levels** button to display the Enter Contour Levels dialog, shown at right.

In the Enter Contour Levels dialog:

- Choose "Exact levels" for the level creation mode.
- Choose "Min, max and number of levels" for the range distribution.
- Enter 0, 50, and 21 as the minimum, maximum, and number of levels respectively.

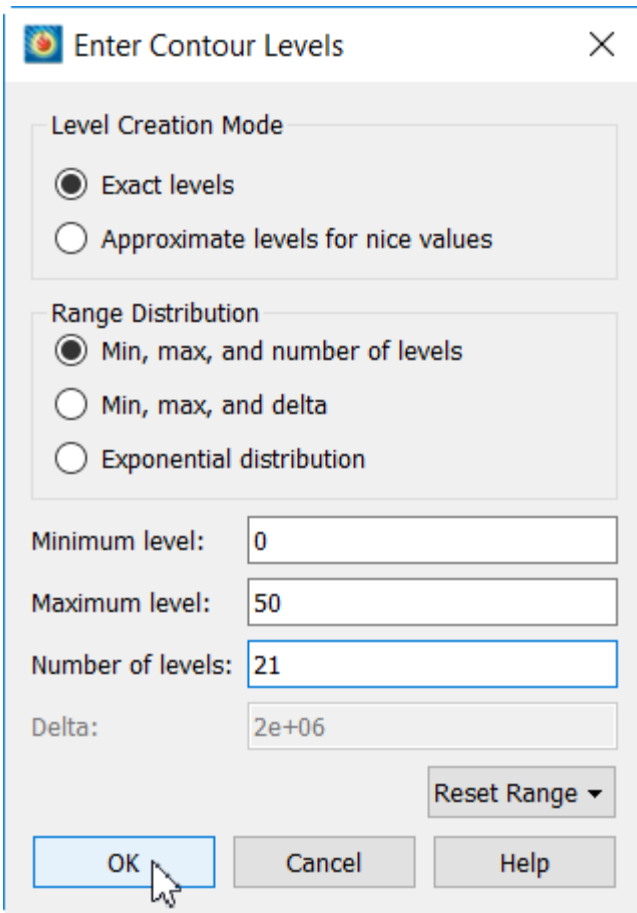

When the dialog is as shown, click **OK**.

You may now move the Contour Details dialog to the side to get a good look at the plot. However, leave it open; we will have need for it again soon.

The contour plot should now look something like this.

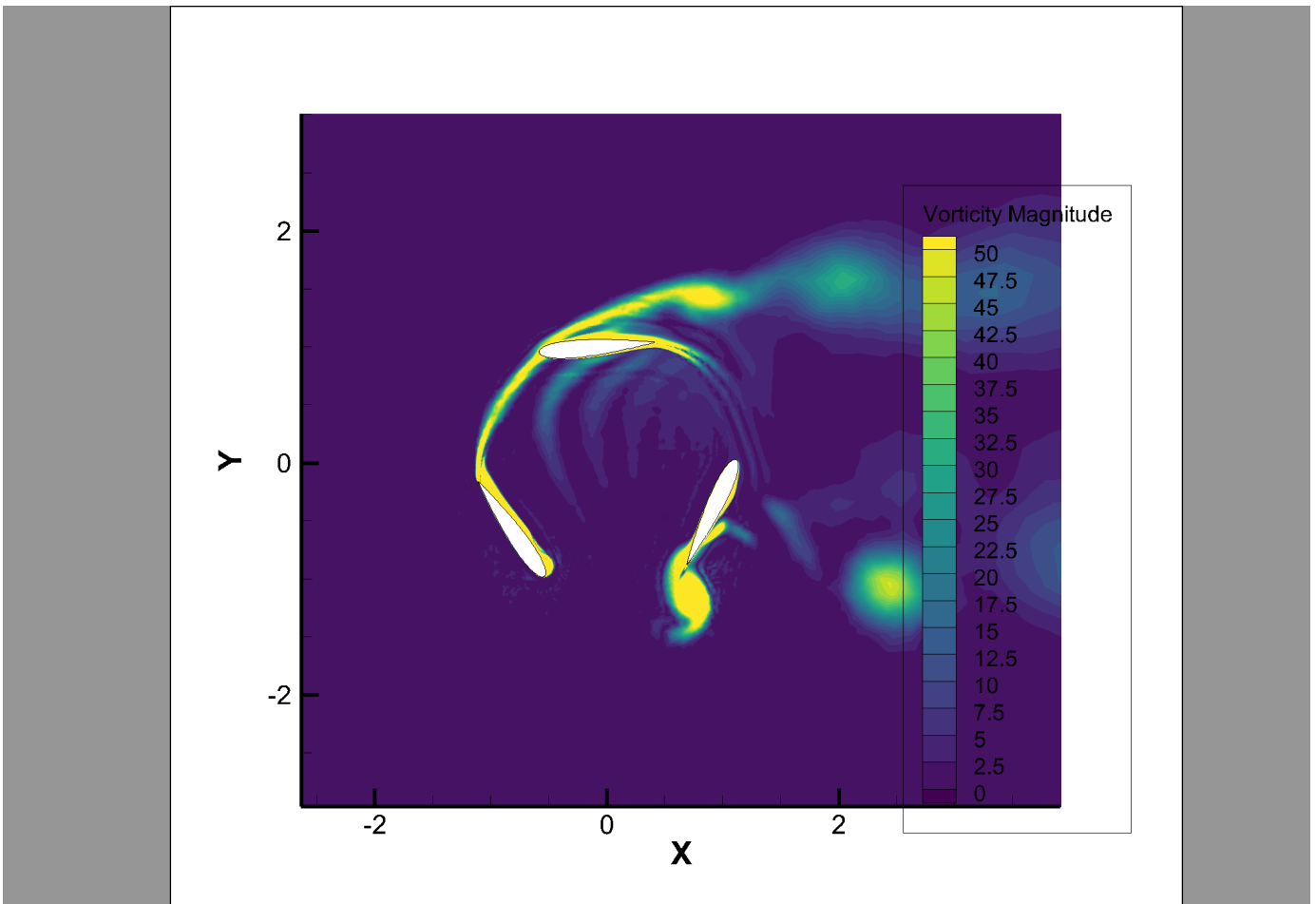

Step 4: Adjust Cutoff

This plot is good, but we can make it better by only coloring areas with vorticity above a critical value, improving the impact of locations of higher vorticity.

Back in the Contour Details dialog, set the contours to cut off below a value of 7. This field is in the lower right portion of the dialog.

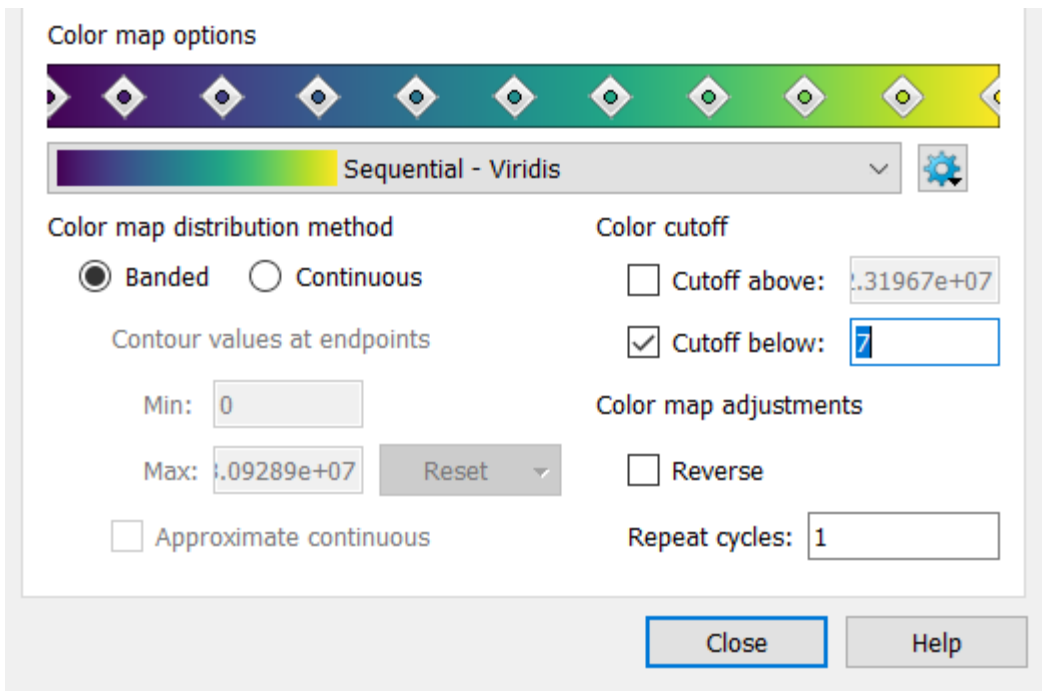

This makes our vortices stand out by eliminating all contouring below 7. You might experiment with slightly lower and higher values to see more or less. Now we must remove the legend as it is overlapping a region of interest on our plot.

Step 5: Polishing the Plot

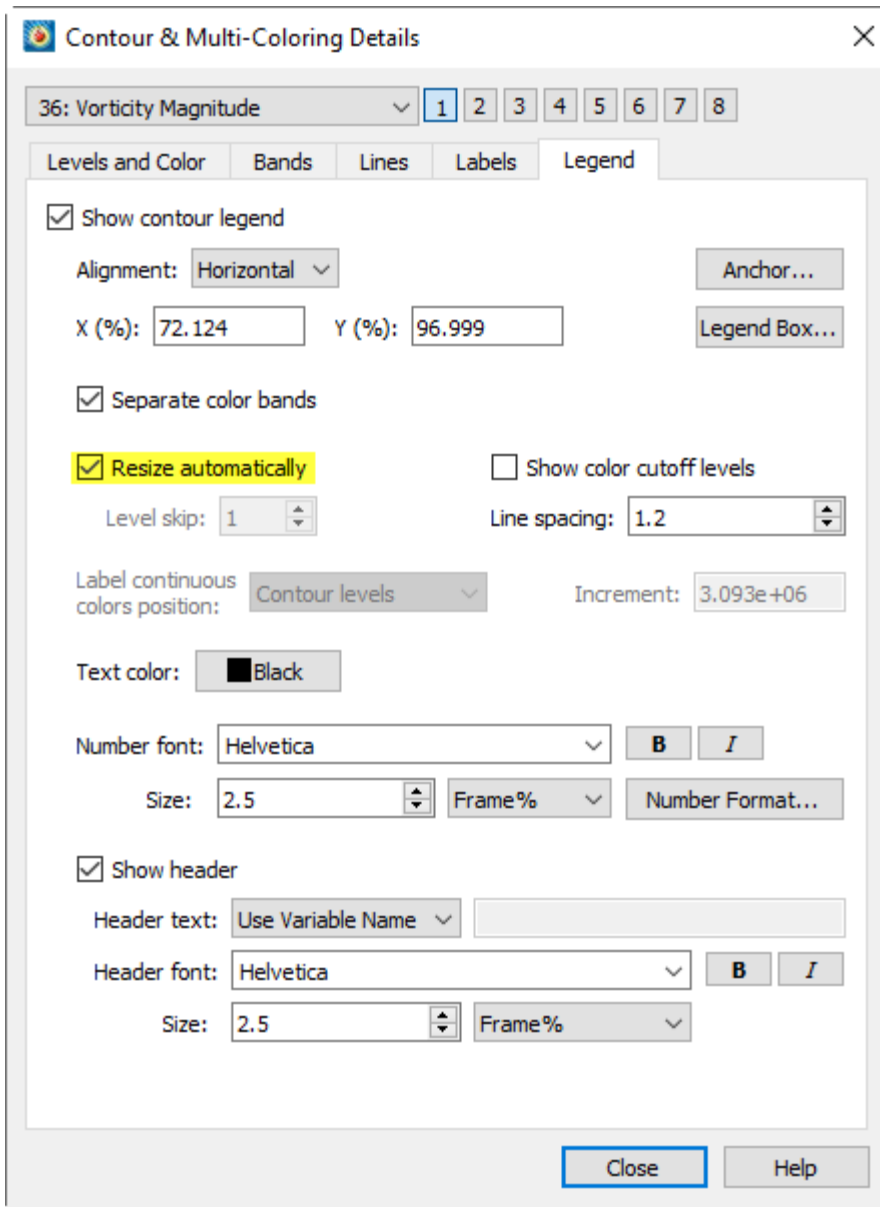

One last trip to the Contour Details dialog. Switch to the dialog's Legend page, change the alignment to horizontal, and activate the Resize Automatically checkbox.

You can close the Contour Details dialog. Switch to the Selector arrow tool, select the legend by clicking on the box around it, and drag the legend to the top center of the plot.



Using the translation tool in the toolbar, move the wind turbine blades a little to the left, so we can see more of the vortices being shed.



You can also translate a plot by holding down the right mouse button and dragging. This works when any tool is active.

You can see our final vorticity plot below.

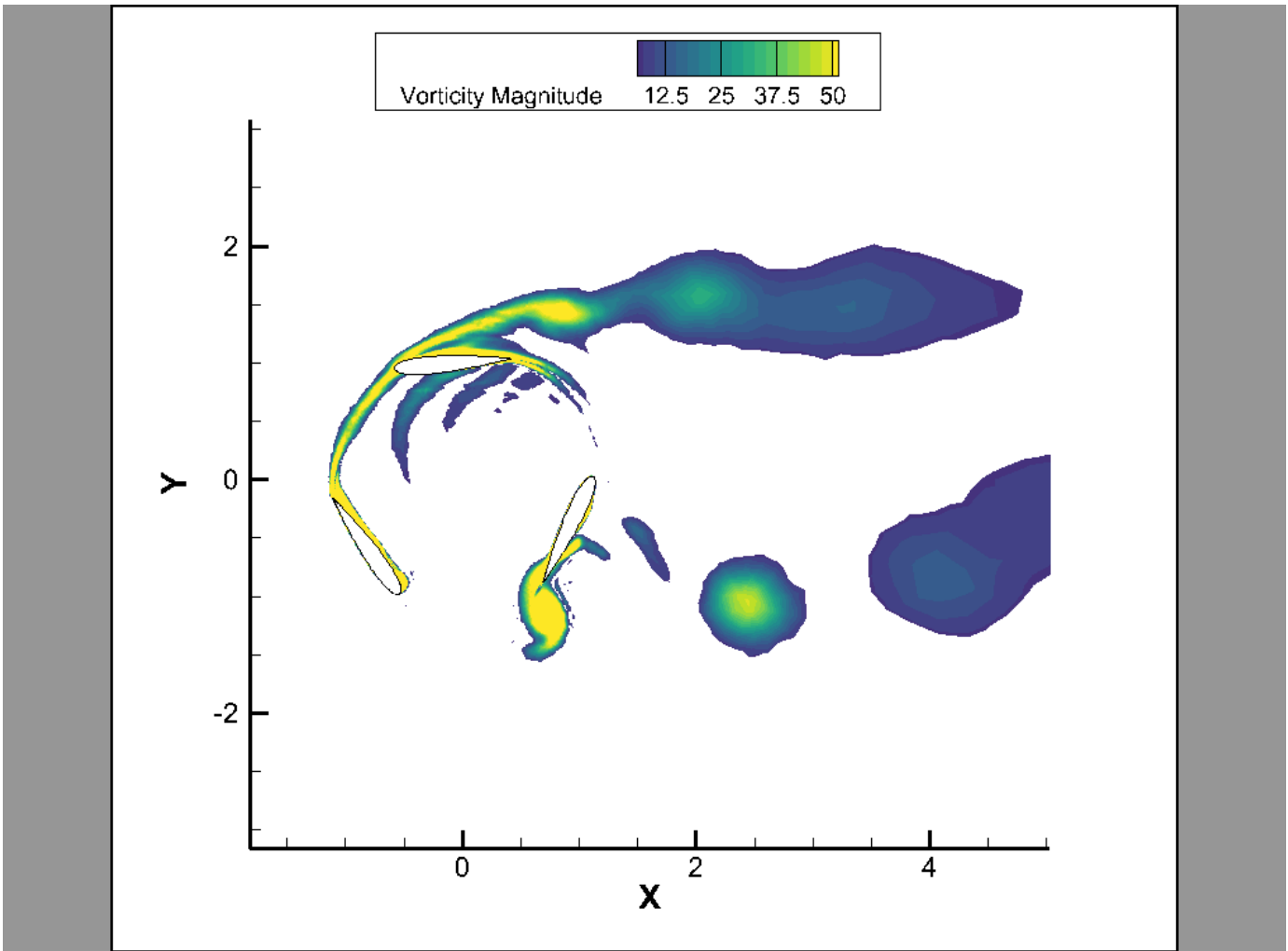

A Tecplot 360 layout (.lay) file containing a snapshot of the final result of this tutorial segment is in [WindTurbineBlades/FinalLayouts/transient_3.lay](#) in the Getting Started bundle.

Step 6: Animate It

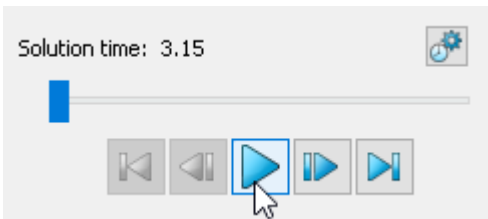

Click the **Play** button in the Plot sidebar to begin animating the plot.

You'll notice that the first time through, the animation is a little slow. This is because Vorticity Magnitude is a calculate-on-demand variable, as we discussed earlier. It takes a moment to calculate this variable the first time each time step is plotted.

After the first time through, the animation will repeat. Since the Vorticity Magnitude variable has already been calculated for each time step, it does not need to be calculated again, and the animation

moves much more quickly and smoothly the second and subsequent times through.

Next Steps

This concludes the Transient tutorial for Tecplot 360. At this point, you may wish to dig in to the User's Manual or Help (**Help>Tecplot 360 Help**) for more details on the product in general or on specific features you've used in this tutorial.

We regularly create videos to introduce users to features of the product, not just introductory topics for new users, but also for advanced users and to highlight new features in the latest release. You can find these on our Web site at www.tecplot.com/category/tecplot-360-videos/?product=360 or on our YouTube channel at www.youtube.com/user/tecplot360.

Finite Element Analysis

This tutorial uses a transient FEA dataset of a connecting rod created with LS-DYNA. The connecting rod data contains 32 time steps with 32 different variables from the LS-DYNA program of a rod rotating about a point. The data may be downloaded from the [Getting Started Bundle](#).

The Finite Element Analysis tutorial contains three different segments. The segments will explore multiple ways to visualize the maximum Von Mises Stress of the rotating rod. We have provided a layout file for the end of each segment, so you can check your work. The overall difficulty, description, and features used in each segment are shown below:

Number and Level	Title and Description	Features Used
1 - Intermediate	Calculating Von Mises Stress Along a Surface - Calculate the Von Mises stress of the connecting rod data set and contour to find areas of high stress.	<ul style="list-style-type: none">• Animation• Color Cutoff• Contour• FEA Post-Processing• Value Blanking• 3D Multi Frames
2 - Intermediate	Data Alter with If Statements - Use an if statement to calculate where a stress threshold is being crossed.	<ul style="list-style-type: none">• Data Alter• Zone Style
3 - Intermediate	Plot Maximum Stress Over Time - Use a macro to plot Maximum Stress over time and link solution times between frames.	<ul style="list-style-type: none">• Frame Linking• Macro Commands• XY Plotting

A video version of this tutorial is available on the web at: www.tecplot.com/category/tecplot-360-videos/finite-element-analysis. The videos may have minor differences from the printed version of the tutorial in this manual, but they cover the same material. The third segment of this tutorial is not in the video series as it contains few visual steps and is better explained in writing.

Calculating Von Mises Stress Along a Surface

This section will calculate the Von Mises stress of the connecting rod data set and contour to find areas of high stress.

Step 1: Load the Data Set

To begin loading the connecting rod data, select **Load Data** at the top of the Welcome Screen. (You may also choose **Load Data** from the **File** drop-down menu in the menu bar, or click the folder icon, second from the left, in the toolbar. These other methods are convenient when the Welcome Screen isn't

visible.) The Load Data dialog appears.

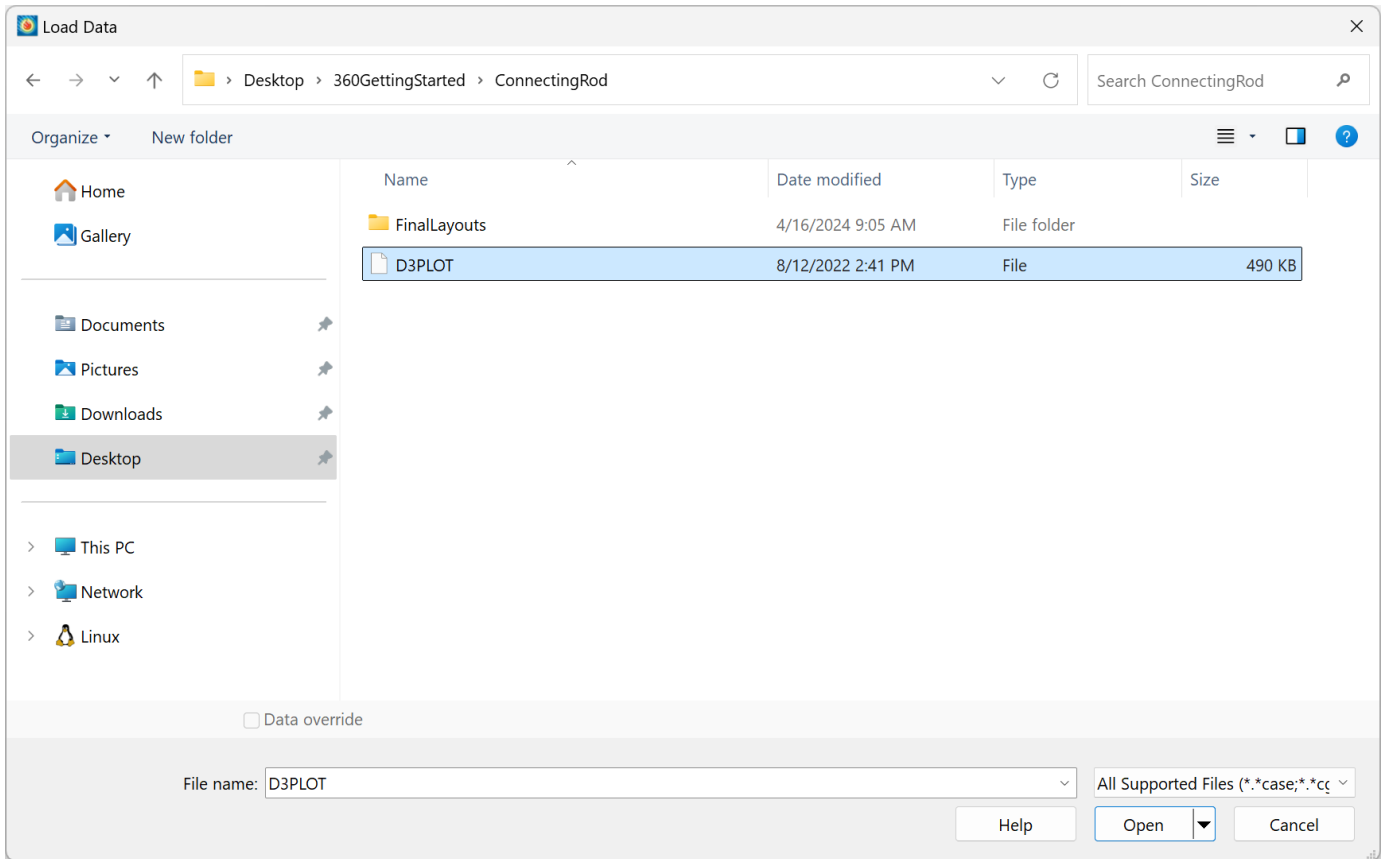

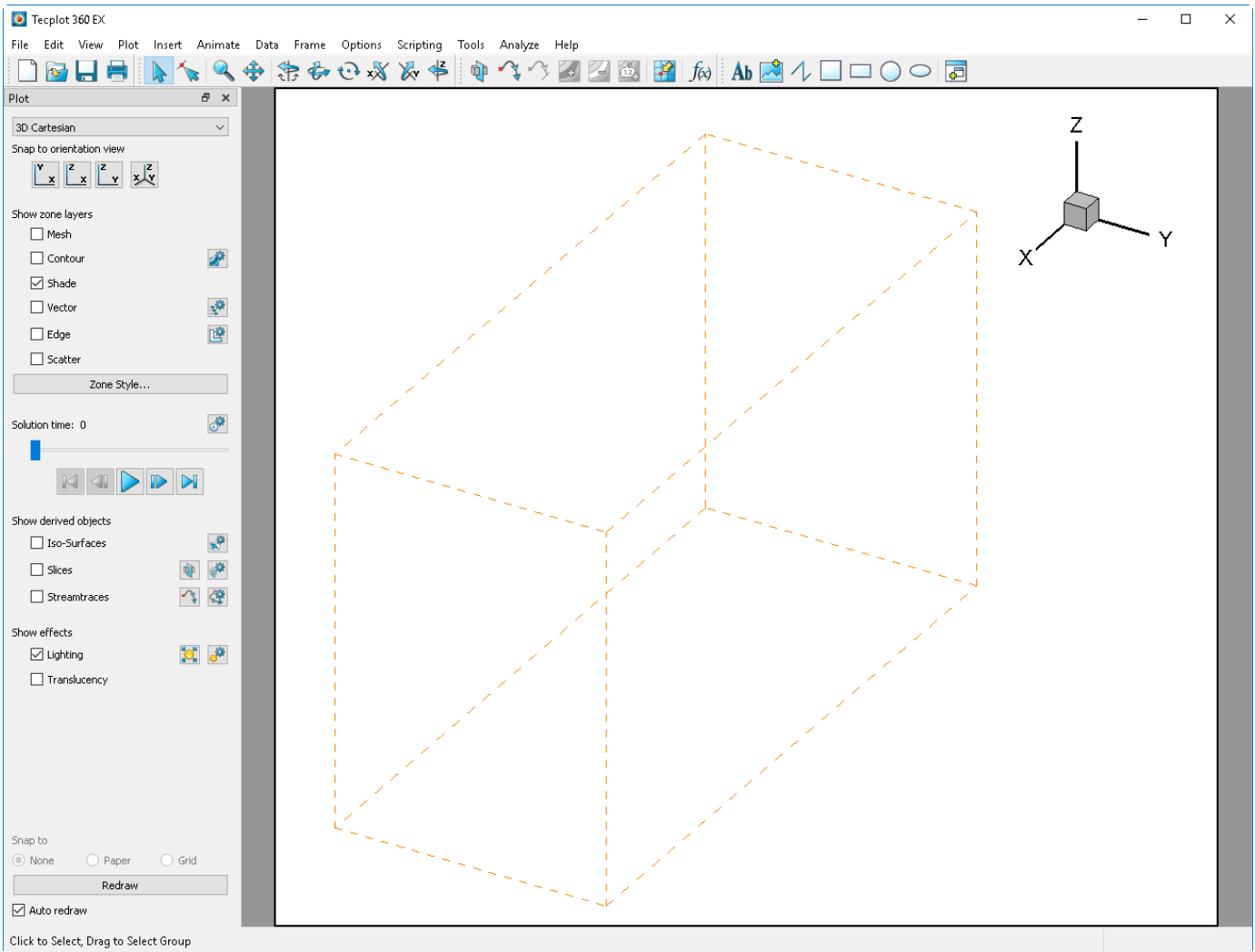

Navigate to the downloaded and extracted **ConnectingRod** folder, open the menu on the bottom right of the dialog, and select **All Supported Files**. Load the D3PLOT file.



Your loaded data only shows an orange dotted box, select **Contour** on the Plot sidebar, select **Yes** on the question dialog that appears, and your plot should look similar to the above picture. Refer to [Understanding Volume Surfaces](#) to learn about the Surfaces to Plot option.

Step 2: Slow Animation Down

Press the **play button**, , on the plot sidebar and notice the machine parts in motion. If the animation is too fast, press the  button above the animation slider and select the **checkbox** next to **Limit animation speed to**, limiting the animation to 12 frames per second.

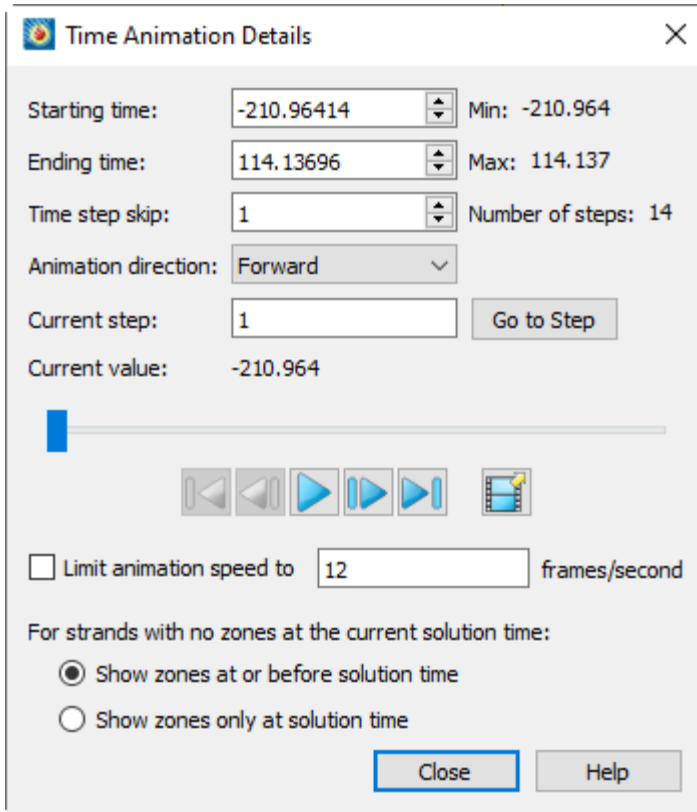

The resulting animation is now slower the next time the **play button** is pressed. Close the **Time Animation Details** window.

Step 3: Calculate Von Mises Stress

Open the **Data Set Information** window by selecting **Data>Data Set Info...** and notice how the data is configured. Each Zone pertains to a different time step and has the same variables. In the variables box, notice that the stress components for each direction are included in the dataset (variables 10-15) thus allowing the ability to calculate the Von Mises stress.

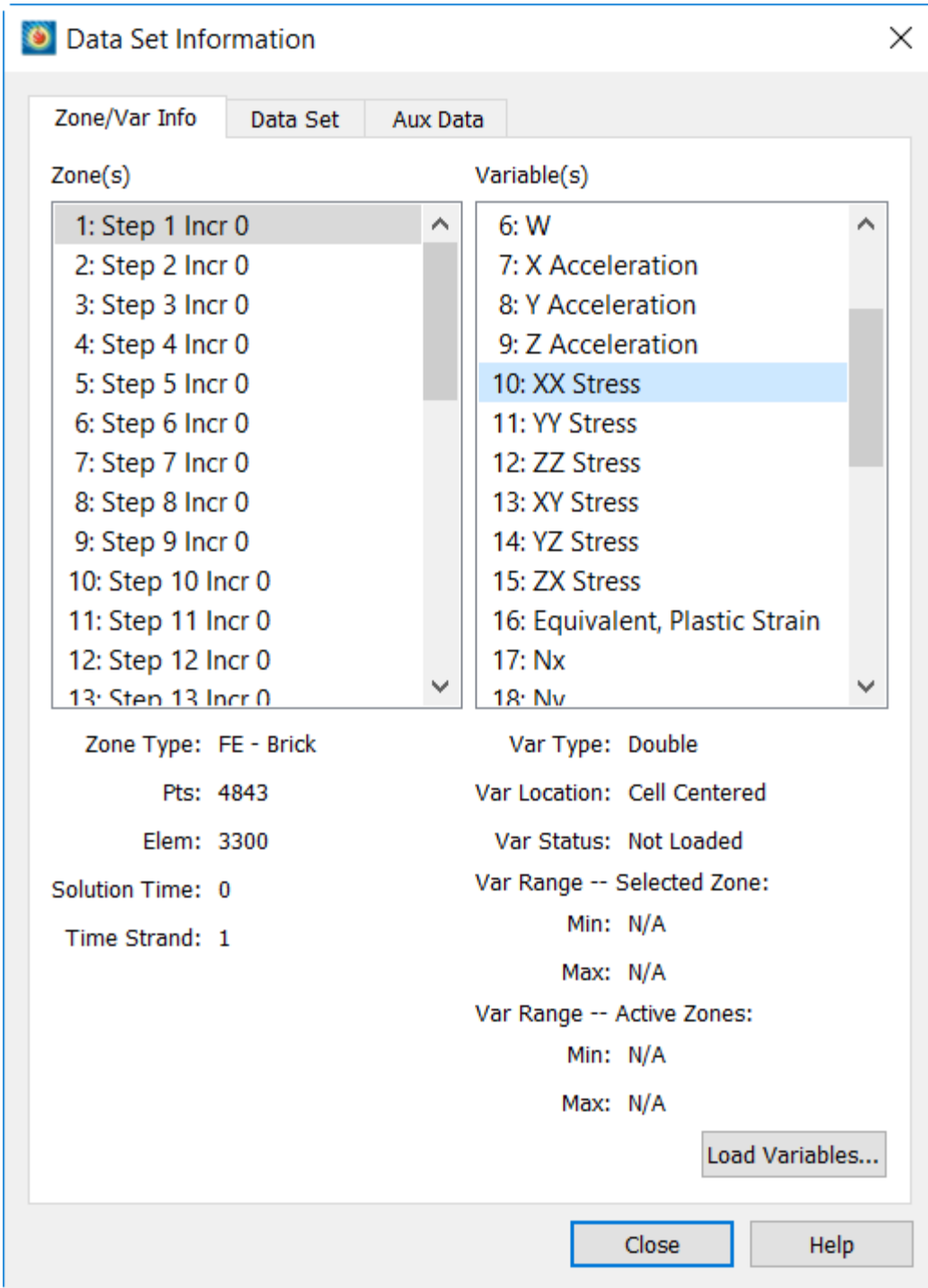

Next, select **Tools>FEA Post-Processing** to open the **FEA Post-Processing Window**. Under the **Derive Variables** section derive "**Von Mises Stress/Strain**" from "**Stress**" (the Stress variables shown below). Click **Add to Data Set**. Now on the Data Set Information page, Von Mises Stress appears as variable 33. Close the FEA Post-Processing dialog and close the **Data Set Information** dialog.

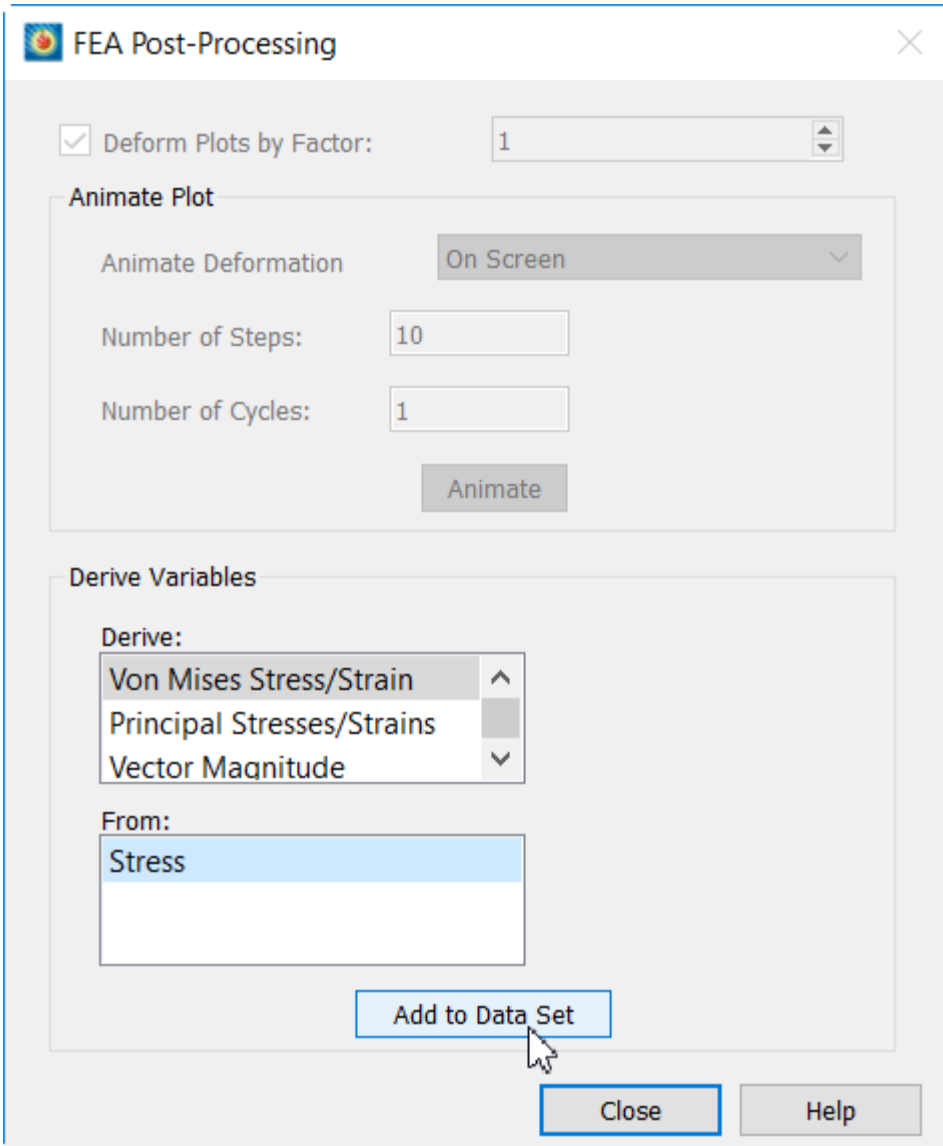

Step 4: Contour by Von Mises Stress

To begin contouring, select the  button next to the Contour checkbox on the plot sidebar to open the Contour & Multi-Coloring Details dialog. Currently, *X Acceleration* is the contour variable of the first contour group. Change the contour group variable to *Von Mises Stress* by selecting the drop-down box at the top of the dialog.

Tecplot 360 allows up to eight contour groups, each with their own contour variable and levels. This allows multiple contour surfaces to be plotted at the same time. In this tutorial, only one contour surface needs to be plotted.

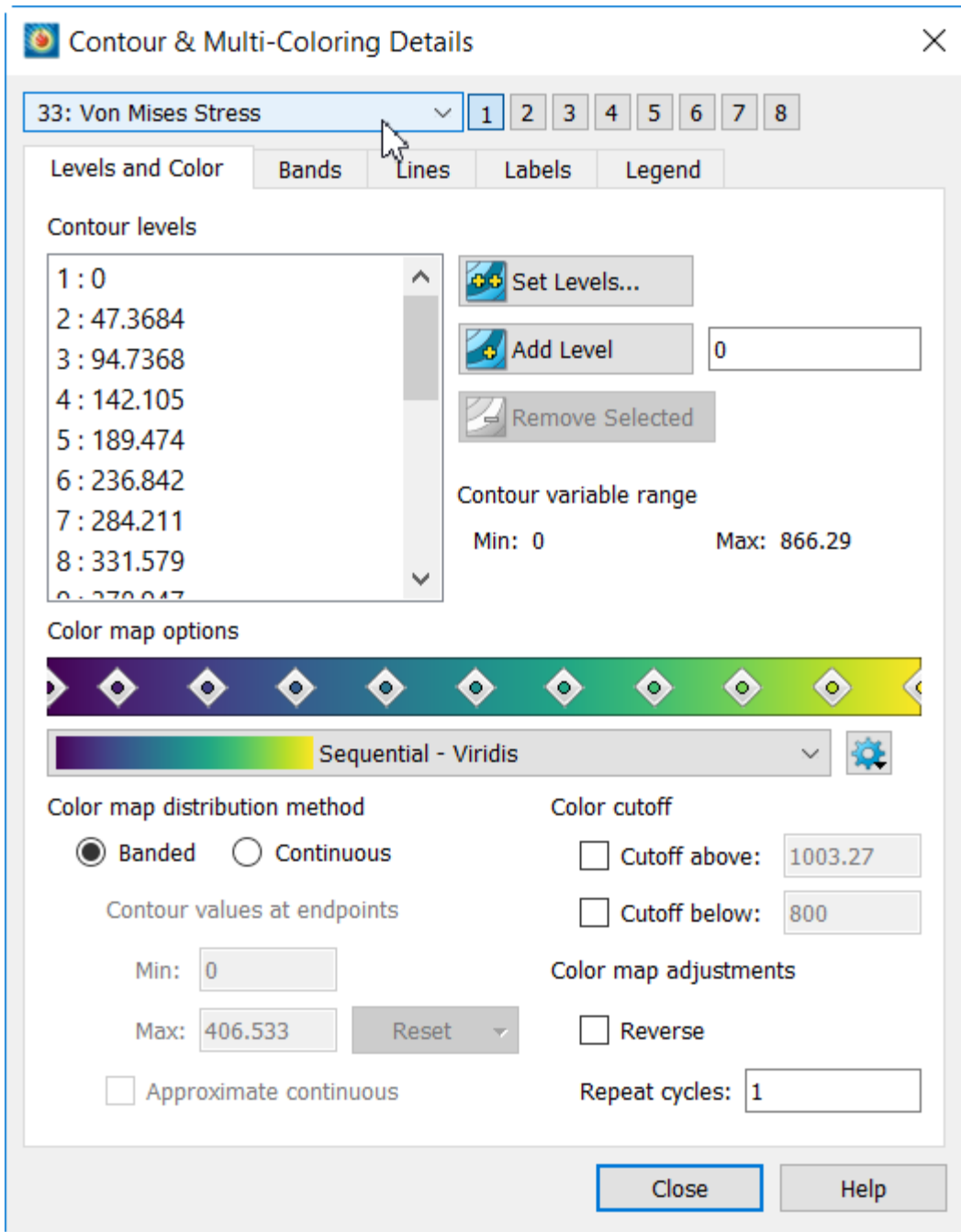

Next, select the **Set Levels...** button and change the minimum level to be 0, maximum level to be 900, and the number of levels to be 21. The resulting **Enter Contour Levels** dialog should look like the picture below. Select **OK** and Close the **Contour & Multi-Coloring Details** dialog for now.

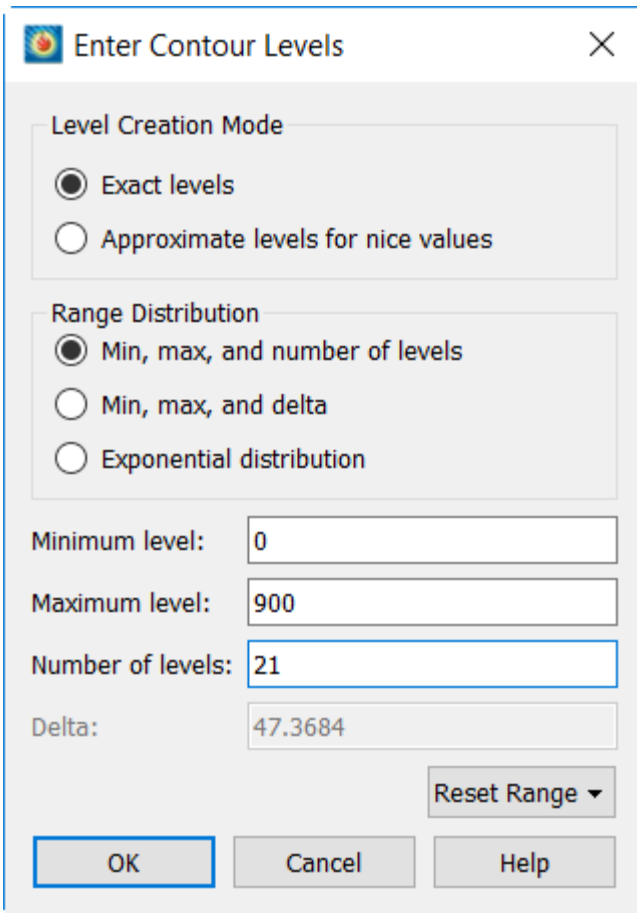

Step 5: Isolate the Connecting Rod

Currently, the crankshaft and cylinder are in the way of viewing the connecting rod. Since the data set consists of one zone and many time steps, Value Blanking will allow the connecting rod to be seen more clearly. Select **Plot>Blanking>Value Blanking** from the toolbar to open the Value Blanking window. Under the Blank when section change the blanking constraints to be when **Von Mises Stress is equal to 0**. Select both the **Include Value Blanking checkbox** as well as the **Active checkbox** to enable the current blanking constraint. Now only the connecting rod is shown. Close the **Value Blanking** dialog.

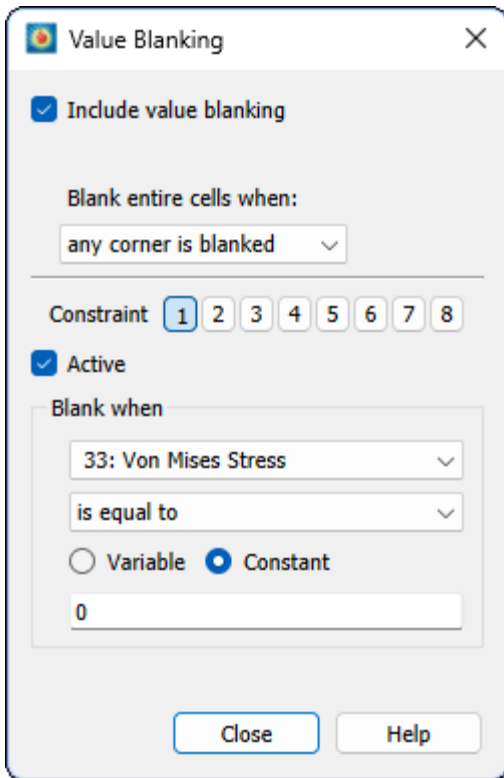

The resulting plot isolates the connecting rod because the Von Mises stress contour values are equal to zero on the crankshaft and cylinder. Though the parts still exist in the data set, they do not give helpful information. In the Value Blanking dialog, multiple constraints can be enabled at once to confine the plot view to very specific areas. For this situation, only one constraint was needed.

Step 6: Identify the Critical Failure Threshold

When clicking the play button again, the Von Mises Stress ranges between 0 and 900 at different steps in the cycle. The values of interest are when the Von Mises Stress exceeds 800. This is the critical failure threshold. To highlight the critical failure threshold, turn on **Color Cutoff** located in the Contour & Multi-Coloring Details dialog and cutoff below 800.

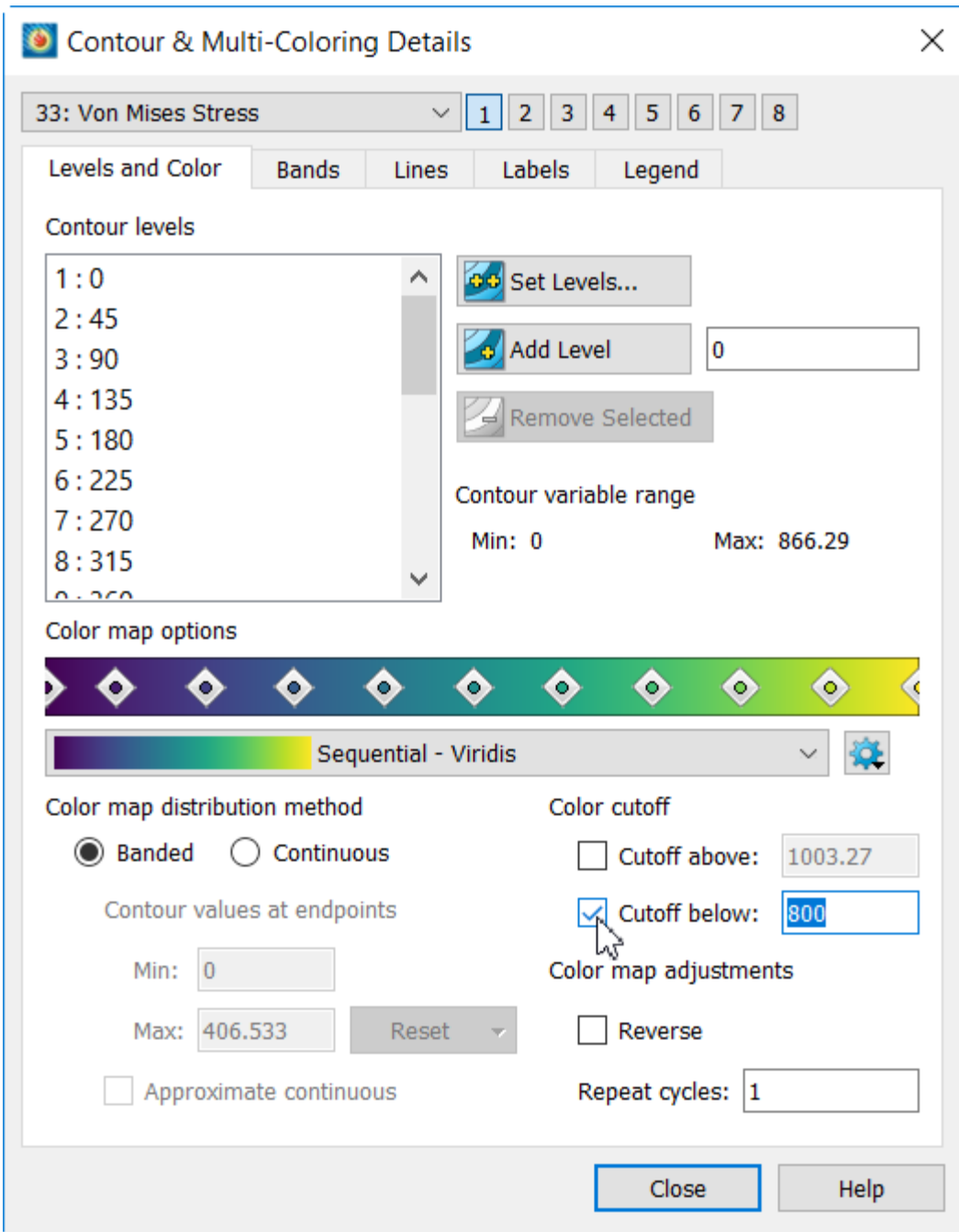

Close the **Contour & Multi-Coloring Details** dialog.

Now when playing the animation, there are two steps that are above the critical failure threshold. Turning on **translucency** by the checkbox on the plot sidebar can give a better view of the part.

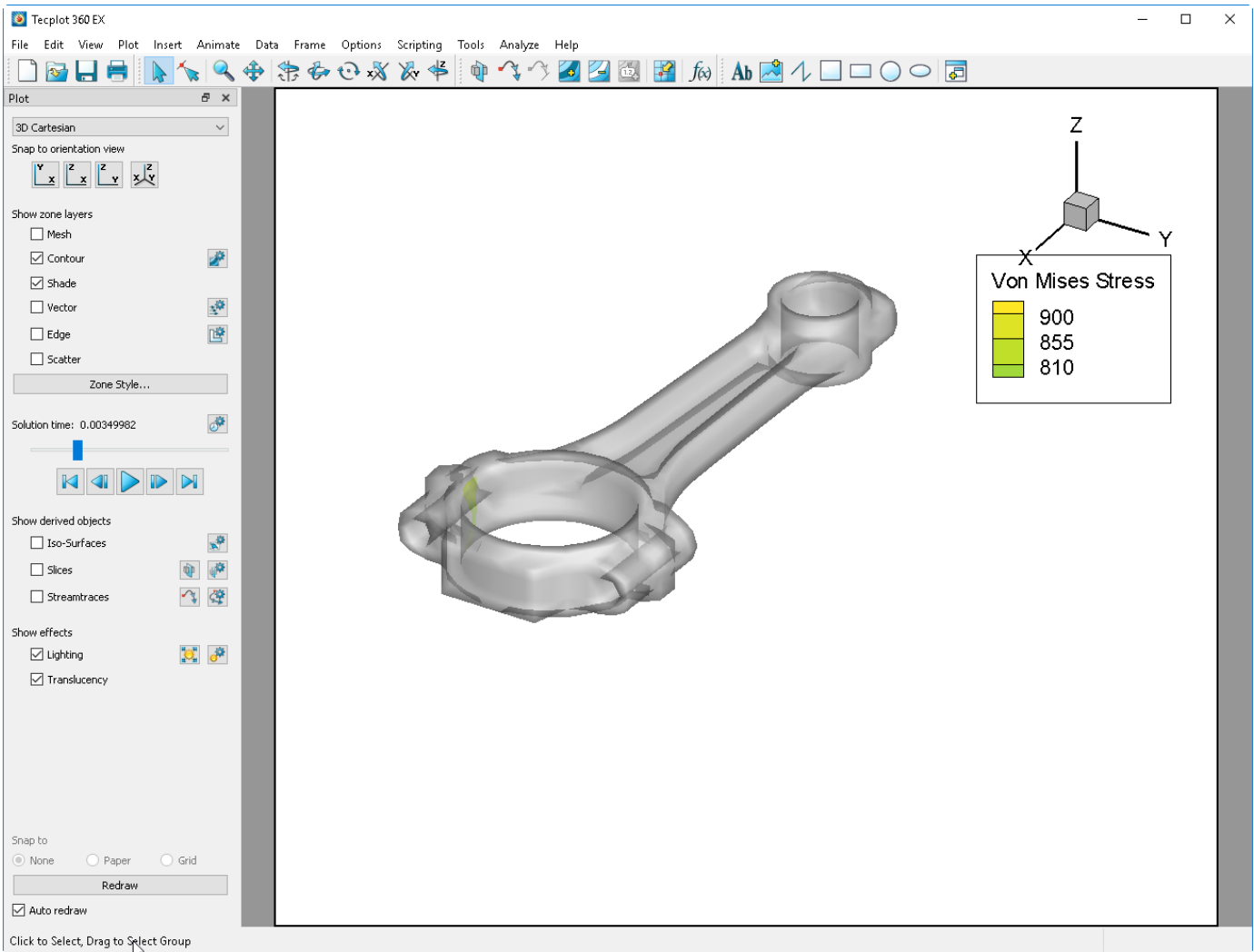

Step 7: 3D Multi Frames

Visualization can be further improved by selecting the 3D Multi Frames option. Select **Frame>3D Multi Frames** then select the **top left option** and three extra frames will appear. These frames are extra orthographic projections of the connecting rod and are created automatically. Notice when the **play** button is pressed again, the frames are automatically linked to each other and all frames animate together.

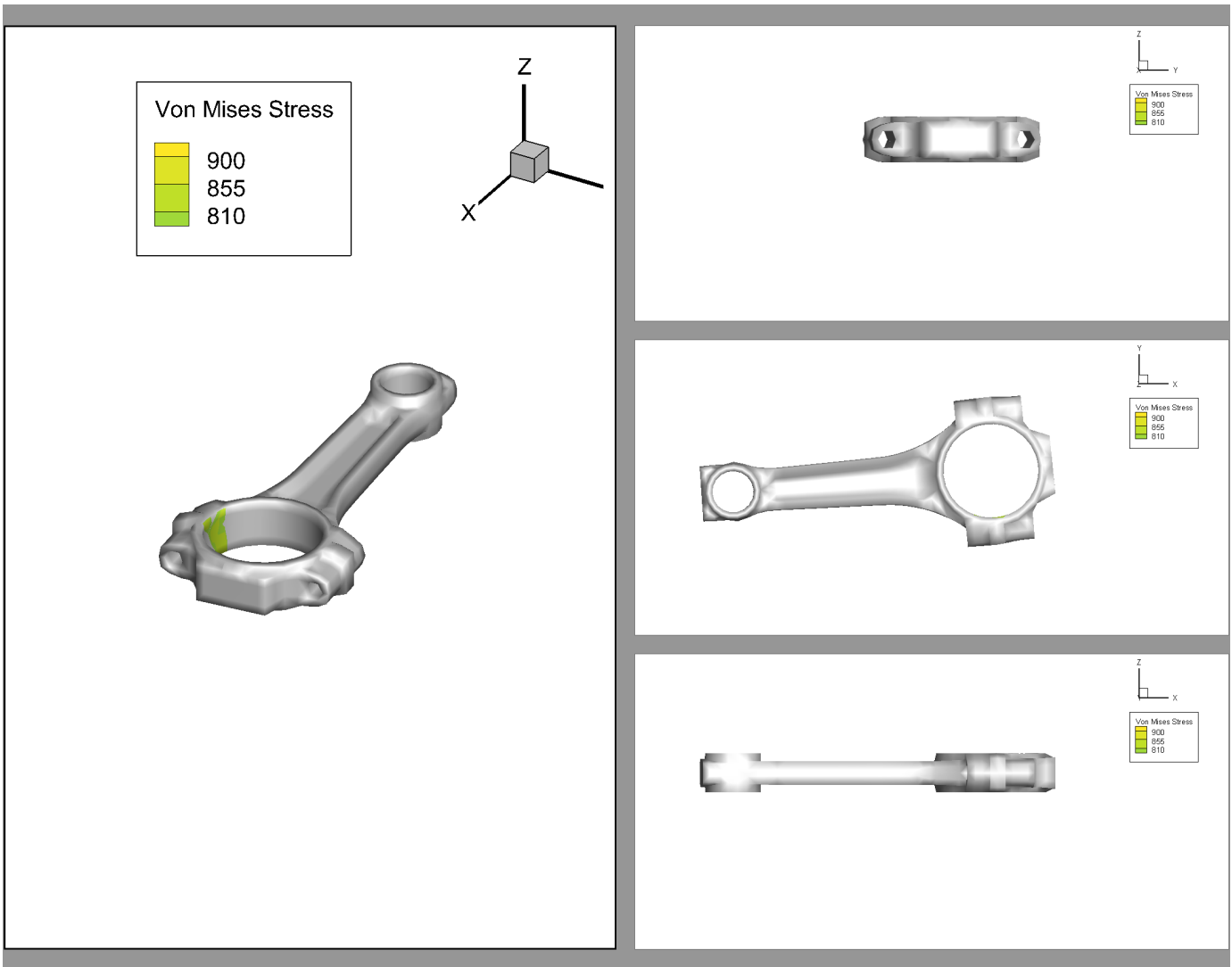

A Tecplot 360 layout (.lay) file containing a snapshot of the final result of this tutorial segment is in [ConnectingRod/FinalLayouts/connecting_rod_1.lay](#) in the Getting Started bundle.

Data Alter with If Statements

This section will use an if statement to calculate where a stress threshold is being crossed.

If you have continued from the previous section, be sure to return your screen to one frame. This can be done quickly by selecting **Frame>3D Multi Frame** and selecting the icon with the red x (on the bottom right). The screen should now only display one frame.

If you have not completed the previous section, calculate the Von Mises stress (see [Step 3: Calculate Von Mises Stress](#)), and turn on Value Blanking for Von Mises Stress equal to zero (see [Step 5: Isolate the Connecting Rod](#)).

Step 1: Specify an Equation

Select **Data>Alter>Specify Equations** from the menu bar to launch the Specify Equations dialog. Type the following equation into the text field: $\{maxStress\} = IF (\{Von\ Mises\ Stress\} > 800, 0, 1)$.

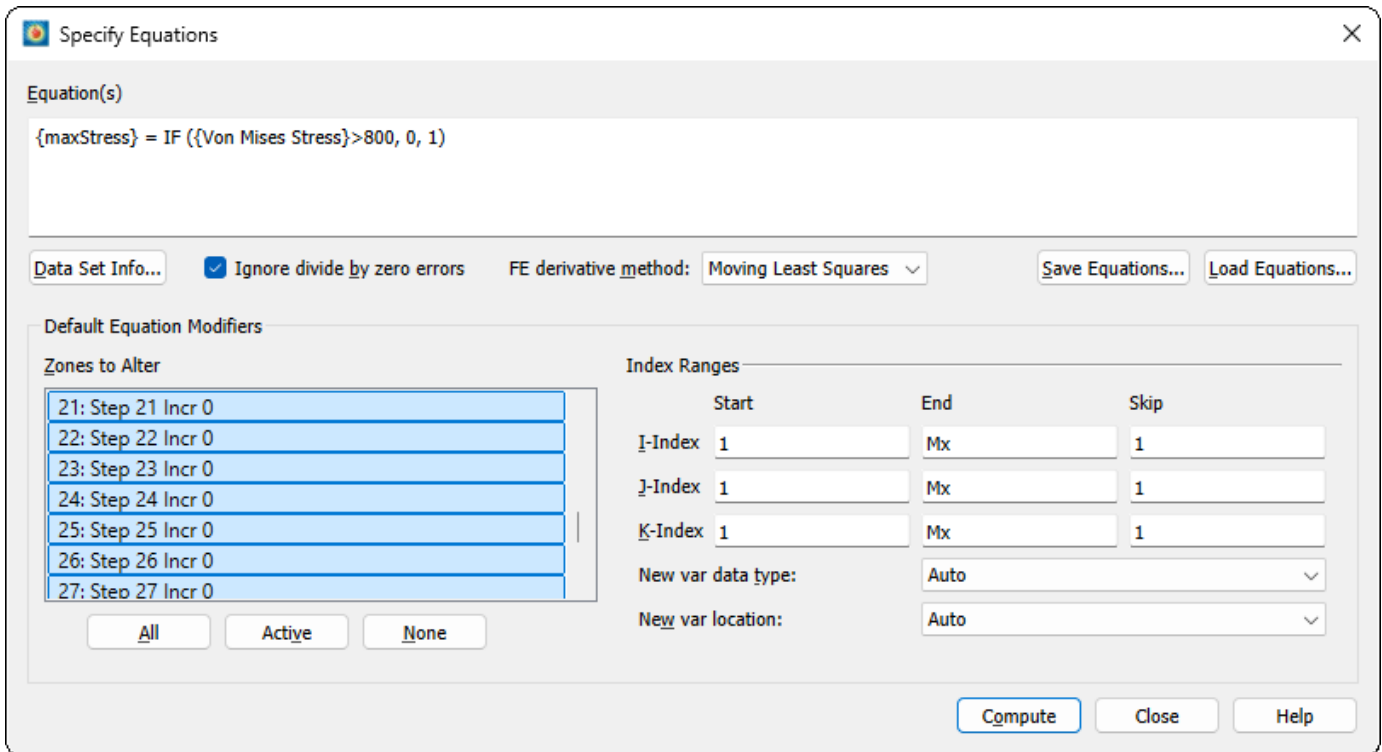

Press the **Compute** button at the bottom and an Information popup will appear, "Data alteration successful." Click **OK** and close the **Specify Equations** dialog.

Step 2: Contour It

Open the **Contour & Multi-Coloring Details** dialog again by selecting the  button next to Contour on the plot sidebar. Change the contour variable to be the variable just created, **maxStress**. Check that the Contour settings looks similar to the image below. Remember to **remove the color cutoff** if it was set in the previous section.

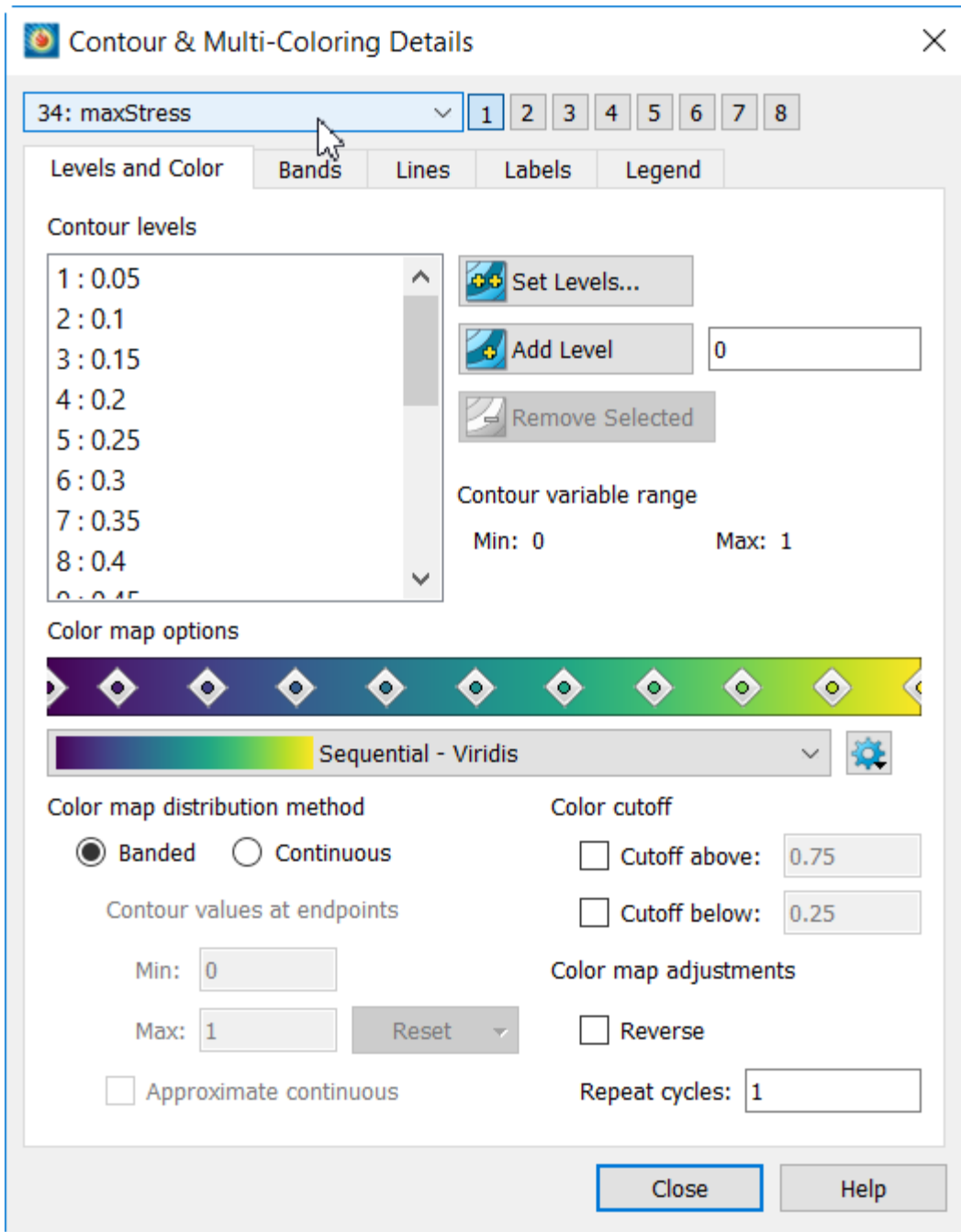

If your data does not contain the amount of contour levels as the above picture, select the **Set Levels** button. This will bring up the Enter Contour Levels dialog. Set the **Level Creation** mode to "Exact Levels" and set the **minimum, maximum, and delta to 0.05, 0.95, and 0.05, respectively**. See [Step 4: Contour by Von Mises Stress](#) for more information.

Now the regions where the threshold of 800, specified in the if statement, are revealed. However, Tecplot 360 is not only plotting 0 and 1, as expected. By default, Tecplot 360 will interpolate values between cell values. Close the **Contour & Multi-Coloring Details** dialog.

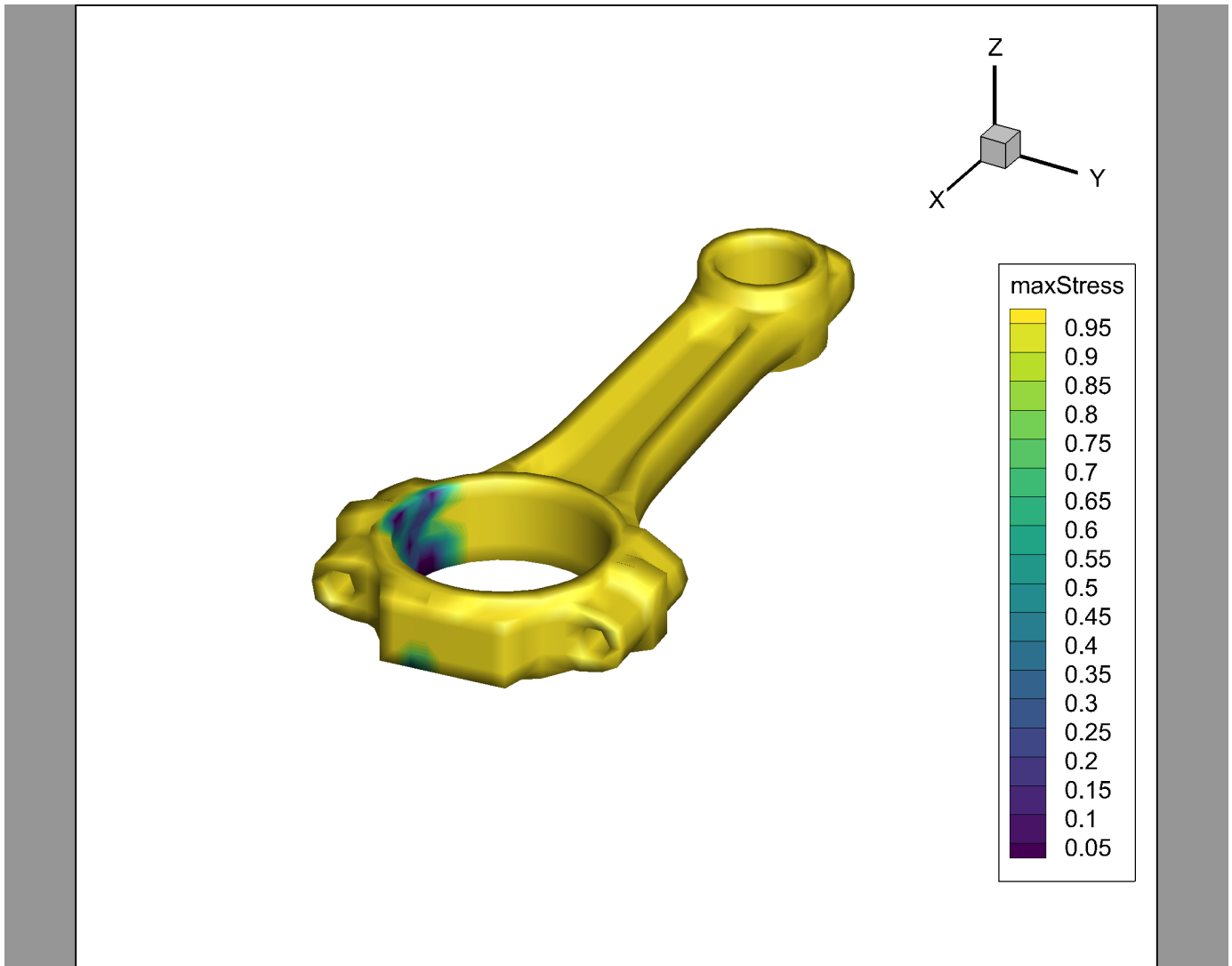

Step 3: Flood by Primary Cell Value

To minimize interpolation by contouring, open the **Zone Style** dialog located on the plot sidebar. Select the **Contour** tab and set the **Contour Type** to "Primary value flood".

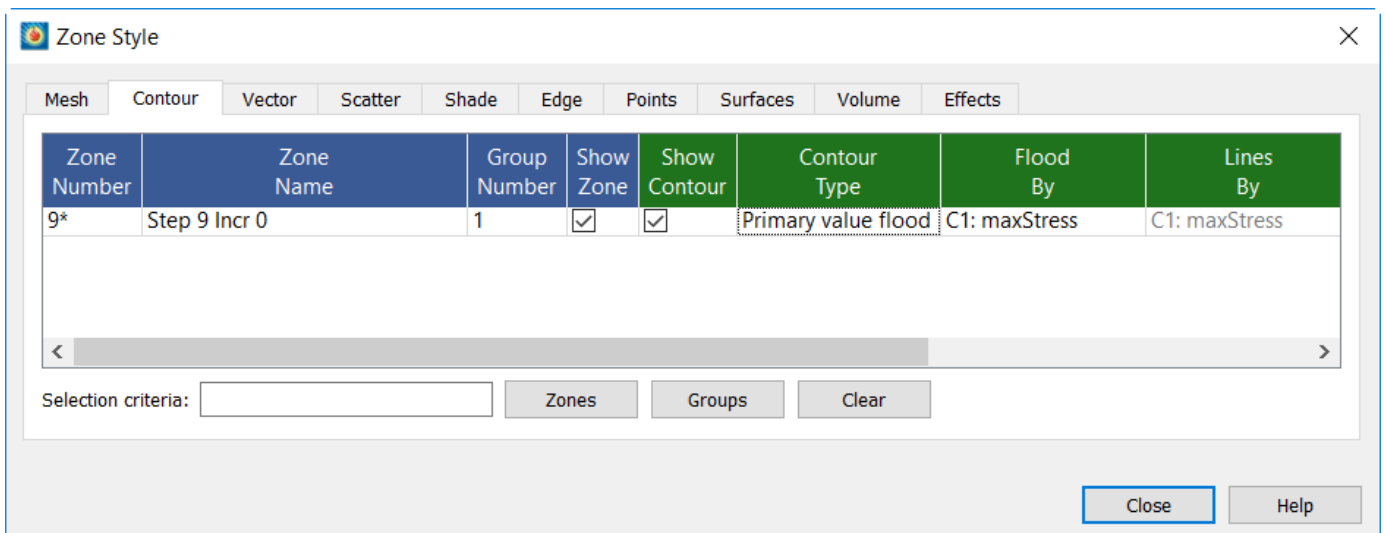

Close the **Zone Style** dialog and notice that the resulting plot contains only yellow and blue. The blue cells occur when the Von Mises stress threshold is met or being exceeded.

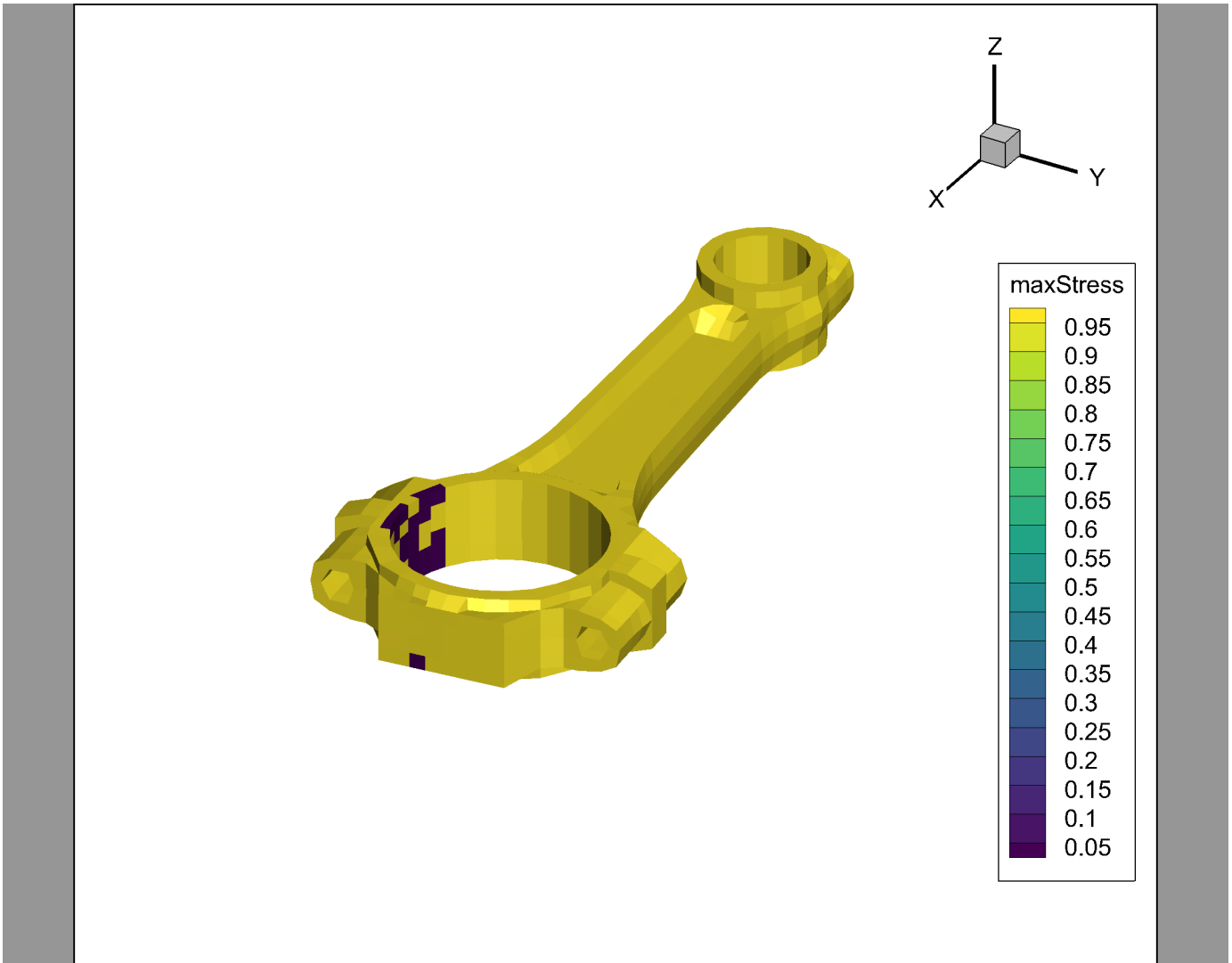

Plot Maximum Stress Over Time

This section will use a macro to plot Maximum Stress over time and link solution times between frames.

Step 1: Load the Macro

If you are continuing from the previous section, return the Contour variable back to Von Mises Stress (see [Step 4: Contour by Von Mises Stress](#) for more information). Then, click **Scripting>Play Macro/Script...** and the **Open Macro** dialog will appear. Navigate to the connecting rod folder again and select `PlotMaxContourOverTime.mcr`.

After selecting Open, the macro will automatically run, creating an XY plot of the maximum value of Von Mises stress at each time step. When the play button is pressed, a marker line follows over the XY plot to track the solution time.

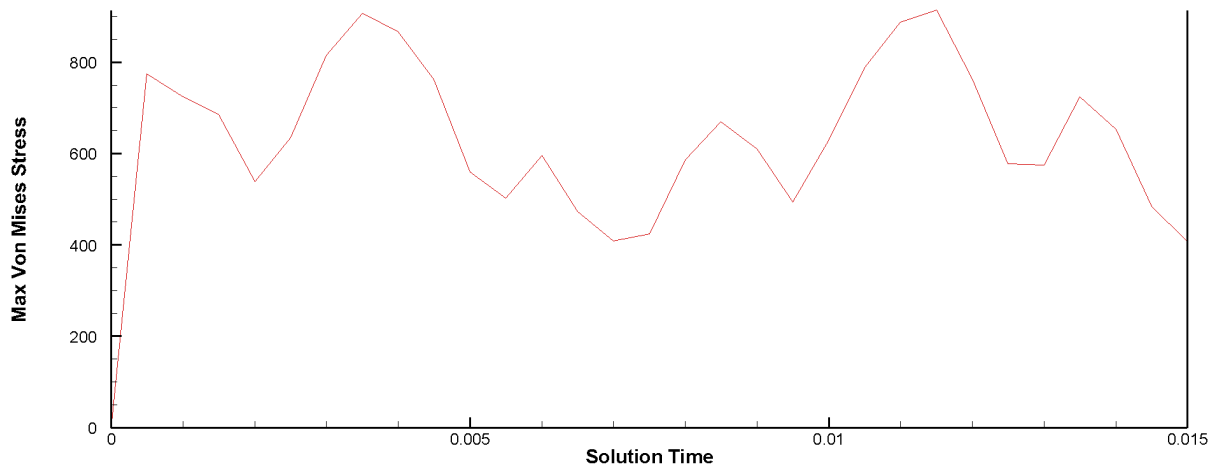

A Tecplot 360 layout (.lay) file containing a snapshot of the final result of this tutorial segment is in [ConnectingRod/FinalLayouts/connecting_rod_2.lay](#) in the Getting Started bundle.

Step 2: Macro Breakdown: Create a Zone

This first portion of the macro file takes the first contour variable and finds its name. Then, the macro finds the number of time steps in the transient data and creates a zone.

```
# Get the variable name of the contour variable (limited to Contour Group #1)
$!EXTENDEDCOMMAND
  COMMANDPROCESSORID='extendmcr'
  COMMAND='QUERY.VARNUMBYASSIGNMENT "C" ContourVarNum'
$!EXTENDEDCOMMAND
  COMMANDPROCESSORID='extendmcr'
  COMMAND='QUERY.VARNAMEBYNUM |ContourVarNum| ContourVarName'
#
# Create a new zone that represents the MAXC value
# over time. MAXC returns the maximum value of the
# variable which is assigned to Contour Group #1. See
# the scripting guide for more detail on MAXC.
#
$!EXTENDEDCOMMAND
  COMMANDPROCESSORID='Extend Time MCR'
  COMMAND='QUERY.NUMTimesteps NUMTimesteps'
$!CREATERECTANGULARZONE
  IMAX = |NUMTimesteps|
  JMAX = 1
  KMAX = 1
  X1 = 0
  Y1 = 0
  Z1 = 0
  X2 = 1
```

```

Y2 = 0
Z2 = 0
$!VARSET |TimeZone| = |NUMZONES|
$!RENAMEDATASETZONE
ZONE = |TimeZone|
Name = "Max |ContourVarName| over Time"

```



Places where vertical bars are used indicate the use of a macro variable. These can be defined by an intrinsic variable (see [Scripting Guide](#)), the `$!VARSETCOMMAND`, or specific `$!EXTENDEDCOMMAND` calls.

To begin, the first two extended commands in conjunction get the variable name by extracting the variable number by the variable defined in [Contour Group 1](#), then using that to extract the name. The script will then use this as part of the new zones name.

The script then determines the number of time steps using the `QUERY.NUMTimesteps` which is then used to create an I-ordered zone (rectangular zone where $J = K = 1$) dimensioned by the number of time steps.

Using the `$!VARSET` command, a new internal macro variable is created based on the total number of zones. Since the new zone is the last zone created, its index is equal to the maximum number of zones. Then the zone is renamed using the Contour variable name found earlier.

Step 3: Macro Breakdown: Alter Variables

The next step is to populate the zone created in step 2 with the maximum value of Von Mises Stress. The key to this process is using the `|MAXC|` intrinsic variable which returns the maximum value of the currently active zones.

```

$!LOOP |NUMTimesteps|
$!EXTENDEDCOMMAND
  COMMANDPROCESSORID='Extend Time MCR'
  COMMAND='SET.CURTIMESTEP |LOOP|'
$!EXTENDEDCOMMAND
  COMMANDPROCESSORID='Extend Time MCR'
  COMMAND='QUERY.TIMEATSTEP |LOOP| SolutionTime'
# Instead of creating new variables, we just reuse variables
# #1 and #2. This keeps the dataset a little cleaner, but if we
# really wanted to create new variables we could do so using
# the $!ALTERDATA command
# Variable #1 represents Solution Time
$!SETFIELDVALUE
  ZONE = |TimeZone|
  VAR = 1
  INDEX = |LOOP|
  FIELDVALUE = |SolutionTime|

```

```

# Variable #2 represent the Max Contour Value
$!SETFIELDVALUE
  ZONE = |TimeZone|
  VAR = 2
  INDEX = |LOOP|
  FIELDVALUE = |MAXC|
$!ENDLOOP

```



`|LOOP|`, when inside a loop, is an intrinsic variable to return the value of the current loop count.

This portion of the macro loops through all time steps activating the current time step through `SET.CURTIMESTEP` which ensure that only the zone in current time are active and used in the `|MAXC|` calculation.

Also in the loop, the `$!SETFIELDVALUE` command is used to set the point value for the specified variable and zone. In this case we are setting the solution time extracted by the `QUERY.TIMEATSTEP` and the `|MAXC|` value to the zone created in step 2.

In preparation for creating a new XY plot the macro performs some simple actions to clean up the plot.

```

# We deactivate the zone we just created because we don't want it
# to display in the current plot. We'll show it in a new frame instead.
$!ACTIVEFIELDZONES -= [|TimeZone|]

# Turn on Time linking because we'll be turning on the
# Solution Time axis marker on the following XY frame and
# we want that marker to update as we animate over time.
$!LINKING BETWEENFRAMES {LINKSOLUTIONTIME = YES}

# Make sure the active frame is at the top of the frame stack. This
# ensures that the new frame we create below will inherit this dataset
$!FRAMECONTROL MOVETOTOPACTIVE

```

First, the newly created zone's field map is removed from showing the original plot, since it may affect how it is displayed. Then Frame linking is turned on and the frame is brought to the top.

Step 4: Macro Breakdown: Create XY Plot

The next step is to create a new XY plot for the newly created zone with a marker which indicates the current time step of the 3D plot.

```

# Now plot the new zone in an XY plot
$!CREATENEWFRAME
  XYPOS

```

```

{
  X = 1.3947
  Y = 4.6447
}
WIDTH = 8.1217
HEIGHT = 3.2862
$!PLOTTYPE = XYLINE
$!DELETELINEMAPS
$!CREATELINEMAP
$!LINEMAP [1] NAME = 'Max |ContourVarName| Over Time'
$!LINEMAP [1] ASSIGN{ZONE = |TimeZone|}
$!ACTIVELINEMAPS += [1]
$!VIEW FIT
$!XYLINEAXIS XDETAIL 1 {TITLE{TITLEMODE = USETEXT}}
$!XYLINEAXIS XDETAIL 1 {TITLE{TEXT = 'Solution Time'}}
$!XYLINEAXIS YDETAIL 1 {TITLE{TITLEMODE = USETEXT}}
$!XYLINEAXIS YDETAIL 1 {TITLE{TEXT = 'Max |ContourVarName|'}}
# Show the solution time axis marker in the XY frame. We turn
# on solution time frame linking to ensure the line updates when
# we animate in the other frame.
$!LINKING BETWEENFRAMES {LINKSOLUTIONTIME = YES}
$!XYLINEAXIS XDETAIL 1 {MARKERGRIDLINE{SHOW = YES}}

```

The XY position and dimensions are provided to create a new frame. This new frame automatically becomes the new active frame. For this reason, changing the plot type and other commands called after the **\$!CREATENEFAME** command only affect the newest frame and not the original.

By default, when the plot type is changed to **XY Line**, line maps are automatically created. The **\$!DELETELINEMAPS** command must be called in order to create custom line maps. In this case, only one line map is needed. The name and zones are assigned to the newly created line map and it is then activated. By default, line maps will use the first two variables of each zone, hence why only the first two variables were edited in step 3.

To clean up the plot for presentation, the title is set using the **XYLINEAXIS** commands. The final two lines ensure that the new frame is linking solution time with the previous one and create a marker line to track the current solution time between both frames.

Next Steps

This concludes the Finite Element Analysis tutorial for Tecplot 360. At this point, you may wish to dig in to the User's Manual or Help (**Help>Tecplot 360 Help**) for more details on the product in general or on specific features you've used in this tutorial.

We regularly create videos to introduce users to features of the product, not just introductory topics for new users, but also for advanced users and to highlight new features in the latest release. You can find these on our Web site at www.tecplot.com/category/tecplot-360-videos/?product=360 or on our

YouTube channel at www.youtube.com/user/tecplot360.

Part 2: Internal Combustion Engines

Internal Combustion Engines

This tutorial uses a transient CONVERGE dataset of a single cylinder engine. The data may be downloaded from the [Getting Started Bundle](#).

The Internal Combustion Engine tutorial contains three different sections. The first section is general Tecplot knowledge of loading the data and changing plot styling. The second section is more objective-based and each segment will be individual. We have provided a layout file alongside the data for the end of each segment, so you can check your work. The overall difficulty, description, and features used in each segment are shown below:

Number and Level	Title and Description	Features Used
1 - <i>Beginner</i>	Loading and Manipulating Data - Load the CONVERGE single cylinder data set into Tecplot 360.	<ul style="list-style-type: none">• Data Loading• Zone Style
2 - <i>Intermediate</i>	Exploring the Data Set - Adding plot styling and derived objects to create an animation plot and exporting to a movie file.	<ul style="list-style-type: none">• Slices• Zone Style• Iso-surfaces• Scatter
3 - <i>Beginner</i>	Loading Cell Averaged Output Files (CONVERGE) - Load a CONVERGE-specific data file and set up an XY Plot.	<ul style="list-style-type: none">• Data Loading• XY Plot

Loading and Manipulating Data

Step 1: Launch Tecplot 360 and Load the Data Set

Start Tecplot 360 from the Start menu (Windows), by typing tec360 in a terminal window (Linux), or by double-clicking the application icon in the Applications folder (Mac). The Tecplot 360 Welcome Screen appears, as shown here. (We will show the Windows version of Tecplot 360 in this document, but the product looks substantially the same on other platforms.).

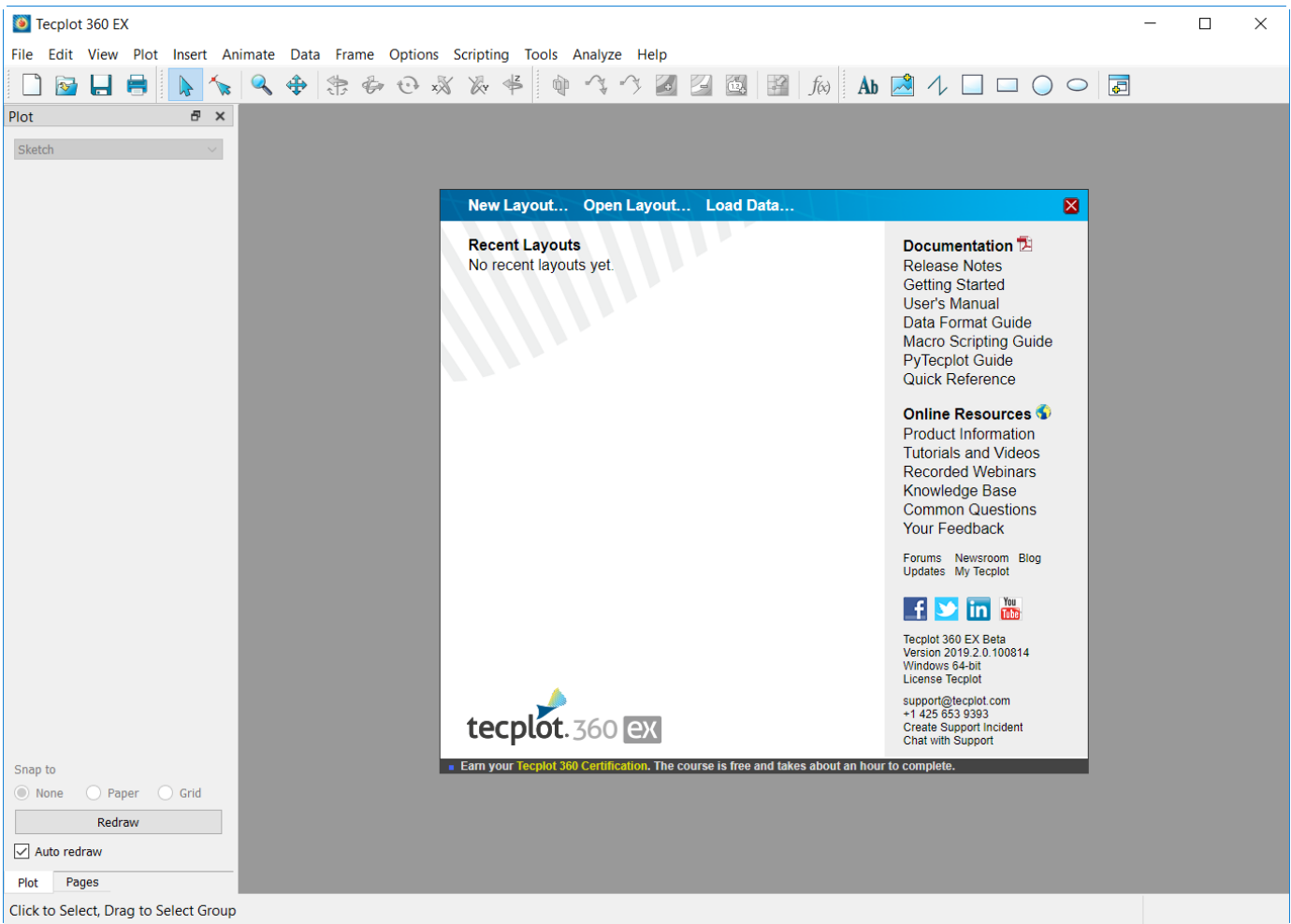

The Welcome Screen appears each time you launch Tecplot 360 and gives you easy access to layouts you have recently worked with, along with quick links to documentation and other resources to help you get the most out of the product.

To begin loading the data, click Load Data at the top of the Welcome Screen. (You may also choose Load Data from the File drop-down menu in the menu bar, or click the folder icon, second from the left, in the toolbar. These alternate methods are convenient when the Welcome Screen isn't visible.)

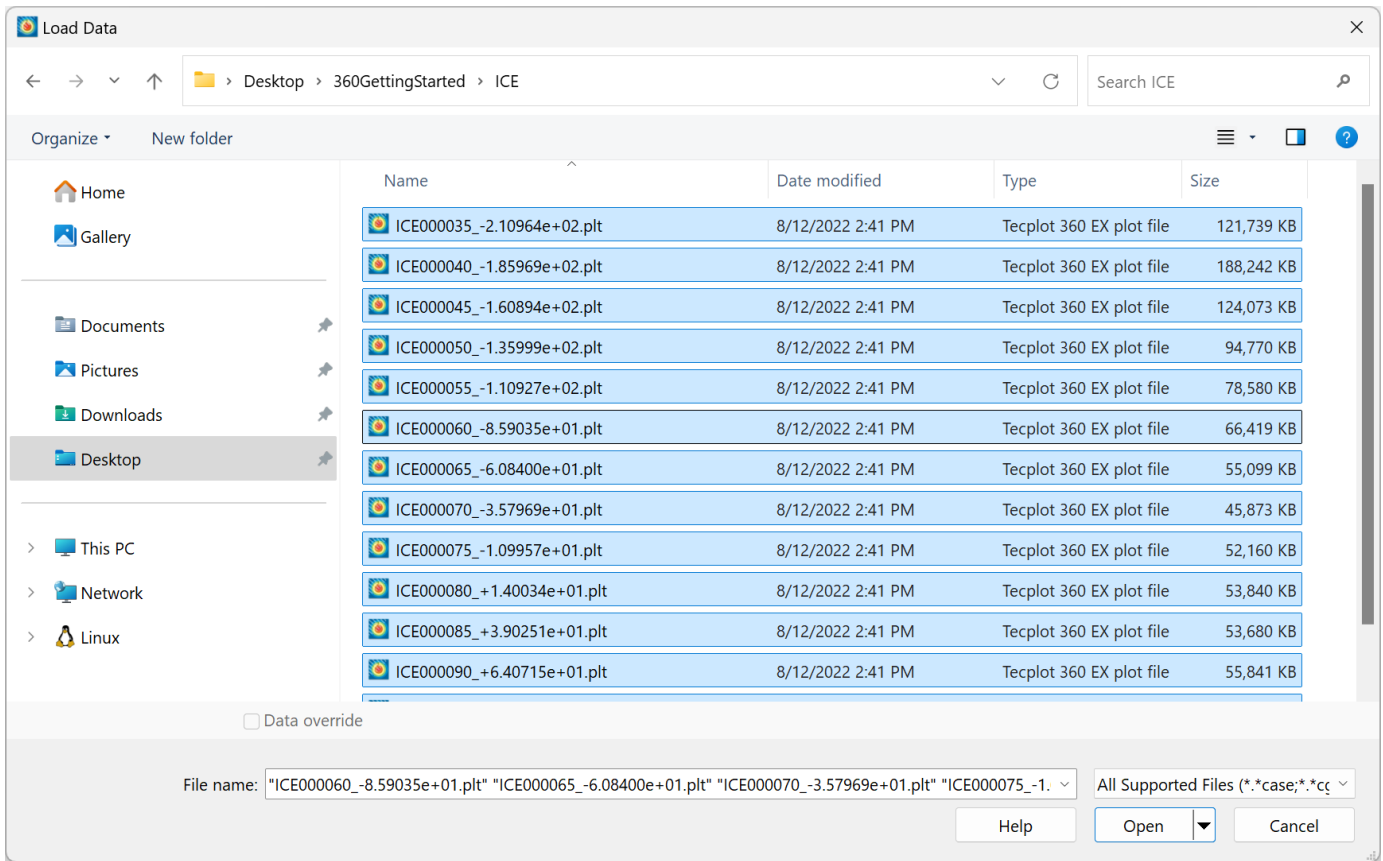

Navigate to your Tecplot 360 [Getting Started Bundle](#) folder then the Internal Combustion Engine (ICE) folder. Select all of the .plt files and select Open. The data files are opened and a 3D plot of the Combustion Engine appears in the Tecplot 360 workspace, as shown here:

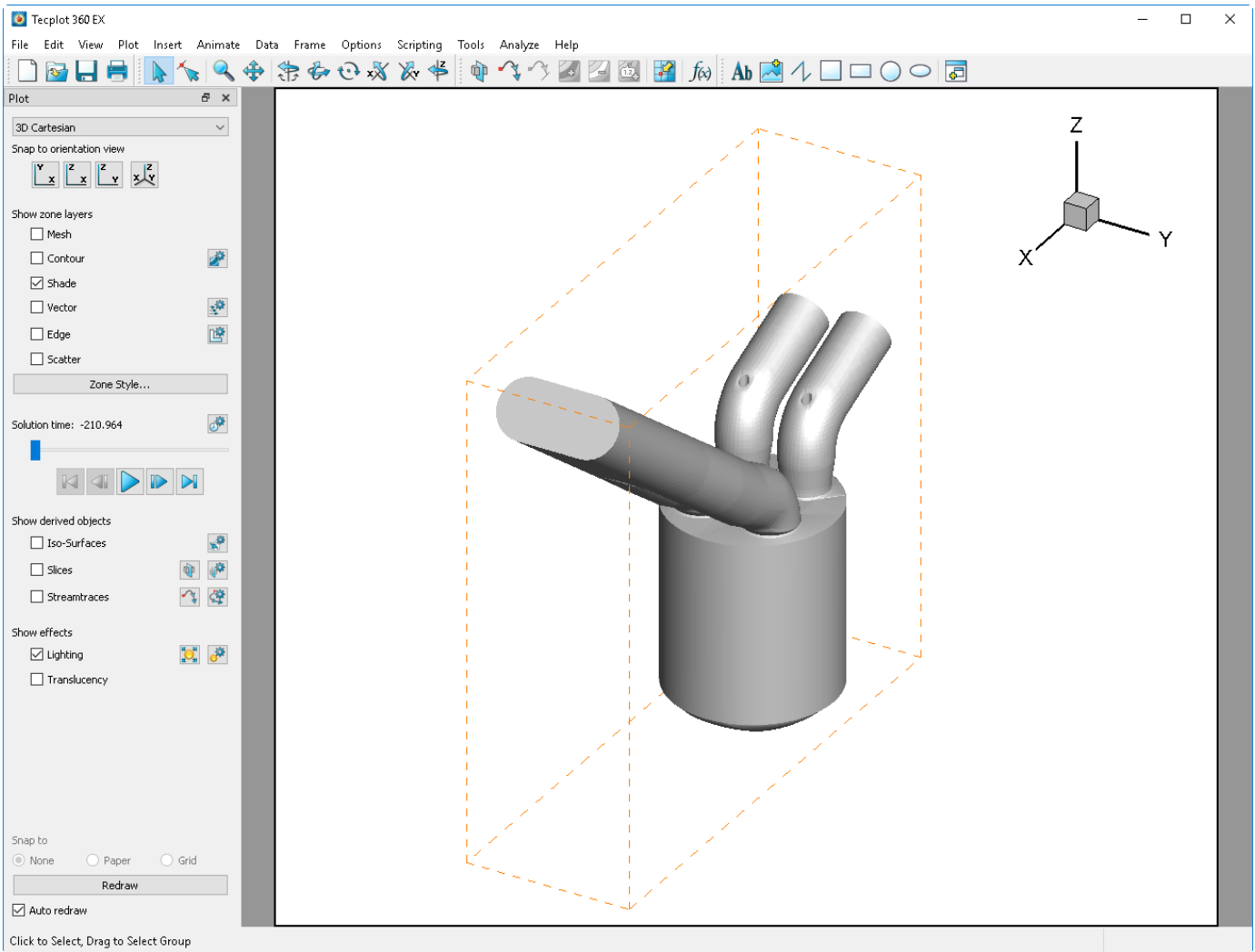

Step 2: Disable Bounding Box for Fluid Volume Zone

You may have noticed a dashed orange line when you first loaded your example file. This is the bounding box of the grid volume zone, which represents the air within the engine. This zone does not have any style (that is, visual appearance) so it would normally be invisible. Tecplot 360 adds the dashed orange line so that you know it is there and can see its dimension. You can choose to hide this line. From the Options menu, select "Show Bounding Boxes for Enabled Volume Zones with No Style". The dashed orange line disappears.

Step 3: Hide Exhaust Ports

Since most of the data of interest lies within the cylinder, hide the exhaust zones by right-clicking the visible zones and selecting "Hide".

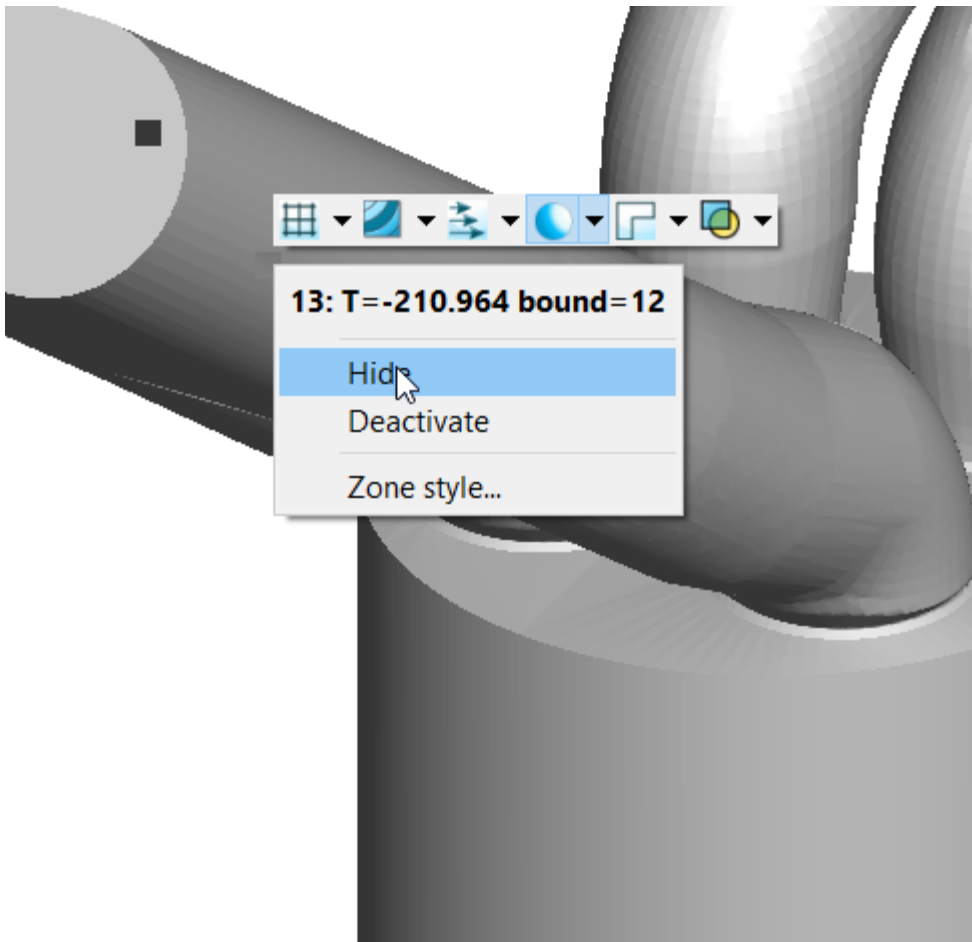

Try to hide as many of the exhaust port zones as possible. After hiding, the plot should look something like this. Do not worry if there are a few zones still active.

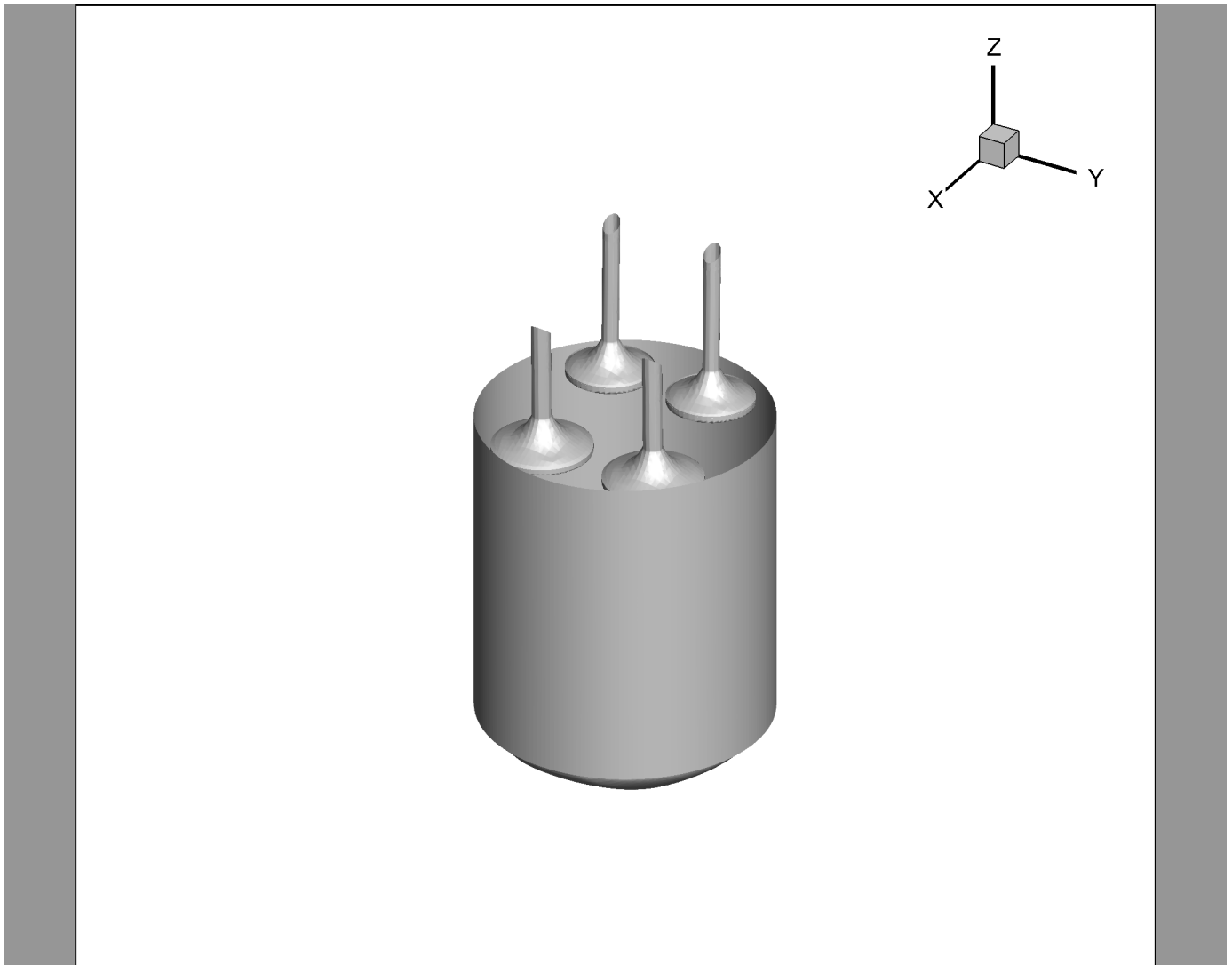

Exploring the Data Set

For this segment, we will be continuing from where we left off. If you have closed Tecplot 360 since the first segment, you can load the provided layout file in [ICE/finallayouts/ICE_GS1.lay](#)

Step 1: Adding a Slice

To add a slice, toggle on the Slices checkbox in the Plot sidebar.

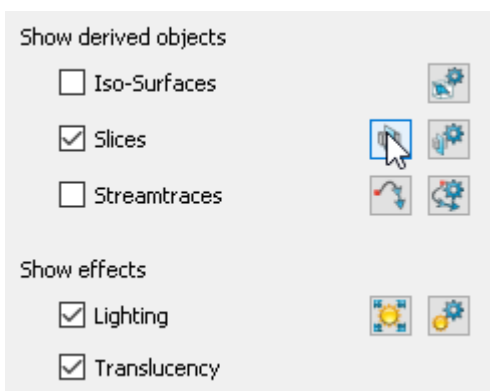

A slice appears through the volume zone but may be hidden by surfaces. To be able to see the slice through the middle of our engine we must turn on Translucency in the Plot Sidebar as well.

From there the slice can be moved by selecting the slice interactor tool to place the slice interactively. The interactor tool can move the slice by clicking or dragging to a desired location. This can also be achieved by selecting the  button next to the Slices checkbox. For now, leave the slice in its default location. The Slice details dialog appears with the current Slice location and orientation.

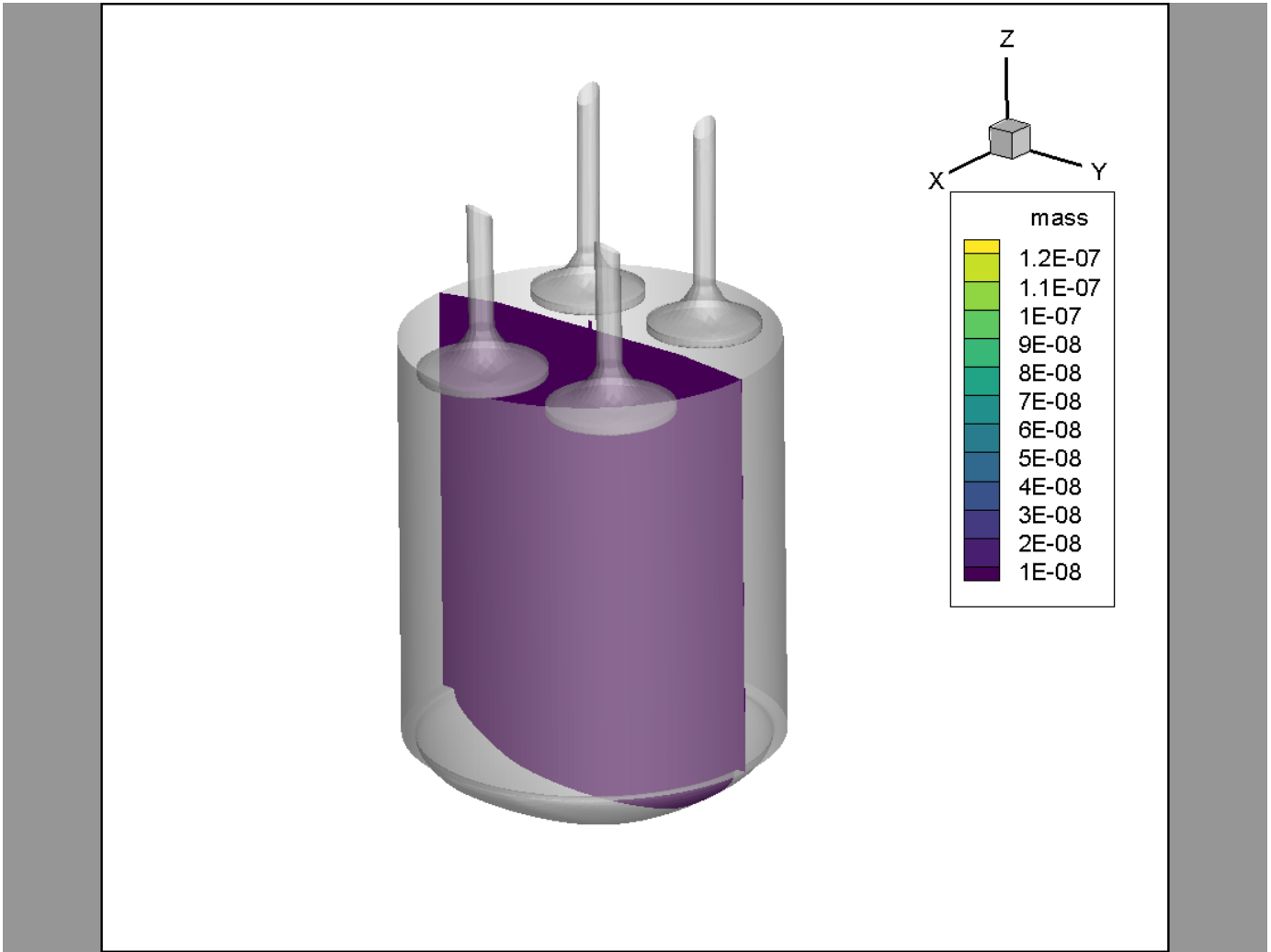

The Slice Details dialog displays the exact slice position.



Step 2: Set Slice Styles

Setting the Contour

If you have the Slice Details dialog still open, navigate to the Contour tab. You will see our slice is being contoured by "mass" as this is the variable currently assigned to Contour Group 1. To change the variable in Slice Group 1, click the  button next to "Contour" on the Plot sidebar. This will open the Contour Details dialog. This dialog can also be opened by selecting the gear icon next to the Flood By field on the Slice Details dialog.

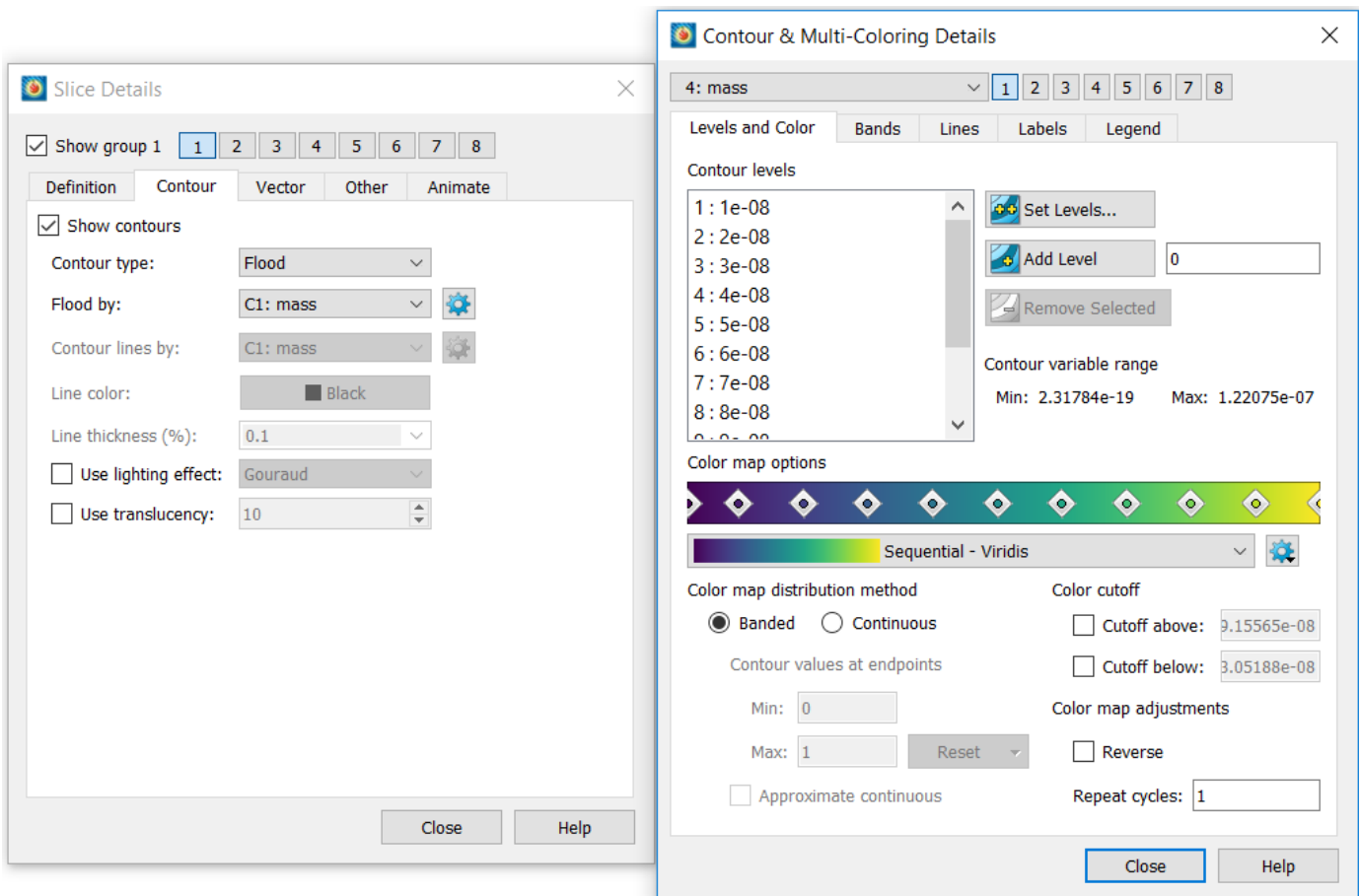

To change the variable of Contour Group 1, select the "1" button at the top of the Contour Details dialog

and select the dropdown list that currently displays *mass*. Select *temp* for now. Close the Contour Details dialog.

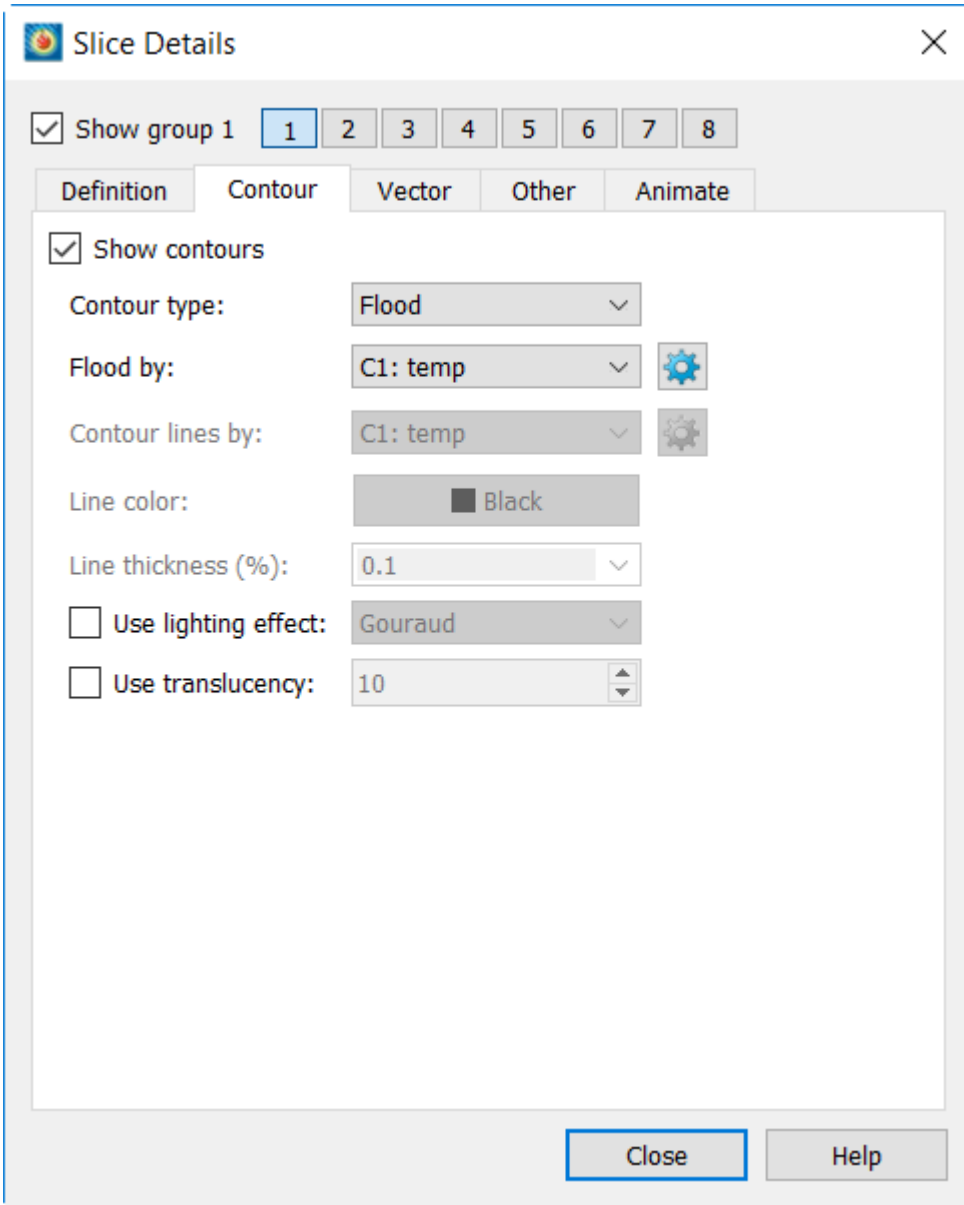

Back in the Slice Details dialog, you should see the variable under the Contour tab change to temp as well. The contour group changed successfully!

Turning on the Mesh

We also want to see the mesh of our slice so we will turn that on as well. Right-click the slice on your screen to open the context menu and select the Mesh option. Shown below:

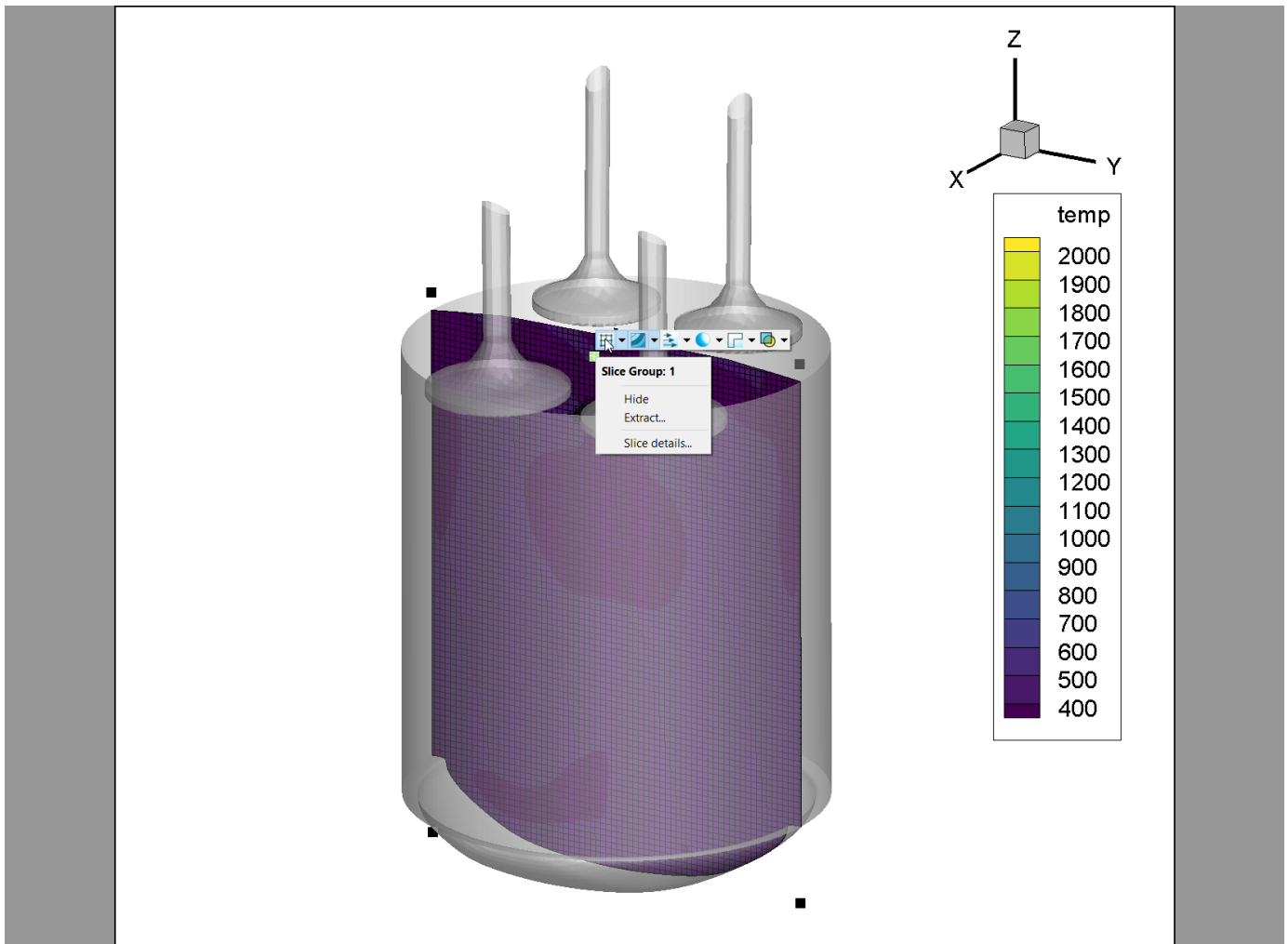

The slice mesh can also be turned on via the Other tab of the Slice Details dialog. Select the magnifying glass in the toolbar to zoom in for a better look.

Using the Forward, Back, and Play buttons on the Plot Sidebar, see how the plot changes over time.

Step 3: Showing Spray Parcels

The slice gives a good indication of the temperatures in the cylinder through time. However, the slice is not the only tool at our disposal. This data set also contains spray information that may be beneficial for our visualization of the engine. To follow along, be sure your Solution Time in the Plot sidebar is set to the first time step.

Open the Zone Style dialog from the plot sidebar and scroll to the bottom of the Zone list. There you will see a zone called "Spray". We want to style this zone to our specifications. To do this, check the Scatter checkbox from the Plot sidebar.

The plot will update with scatter symbols for every zone. This is not what we want though. We only want to show the scatter symbols for the "Spray" zone. In the Zone Style dialog, select the Scatter tab and highlight every zone except the "Spray" zone, right-click the "Show Scatter" column and select No.

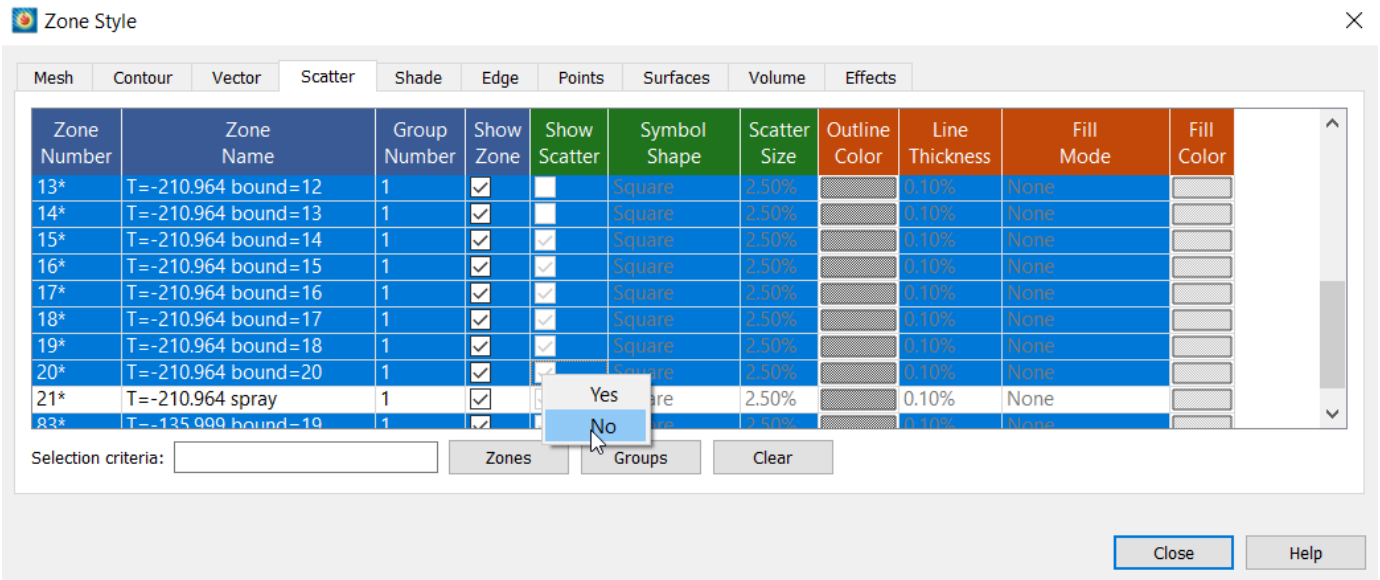

Step 4: Changing Spray Parcel Size

Now the "Spray" zone is the only one showing a scatter plot but displaying as same sized squares. In the Scatter tab, right click the symbol shape and change it to Sphere.

Then we also want to change the symbol size, right click the column for Symbol Size and select the "Select Variable" option.

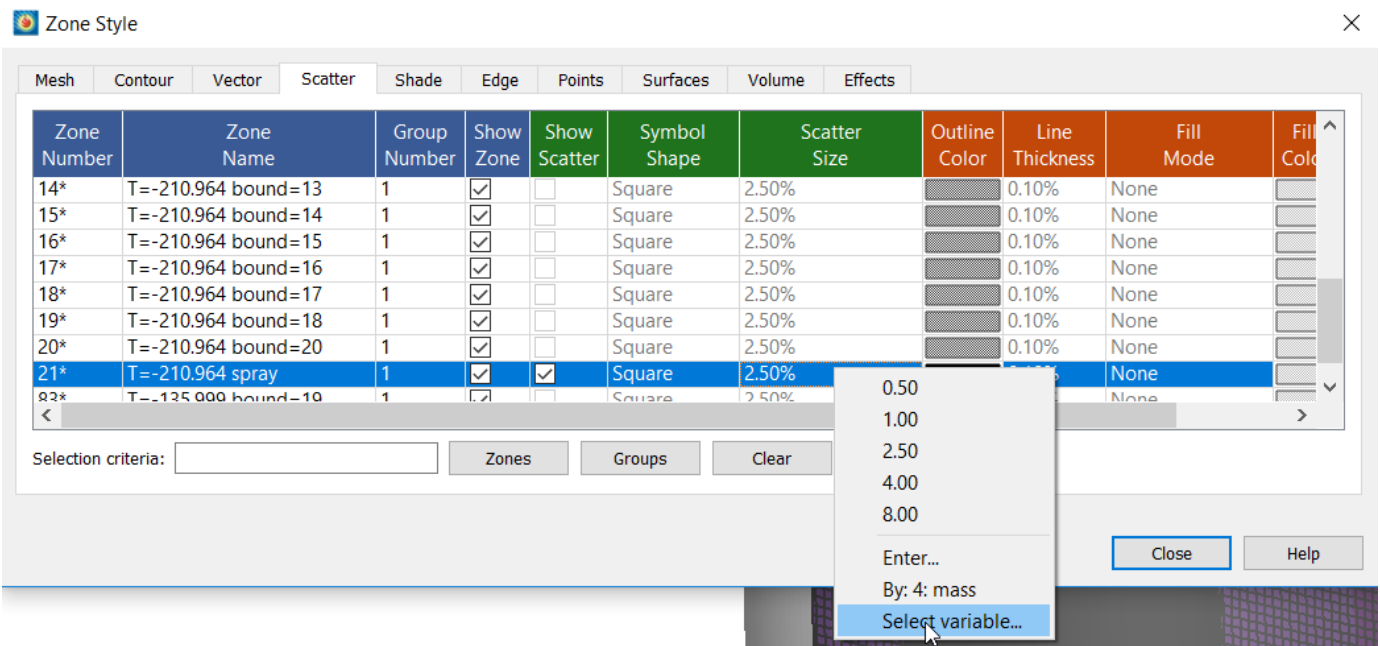

This will open the Scatter Size/Font menu.

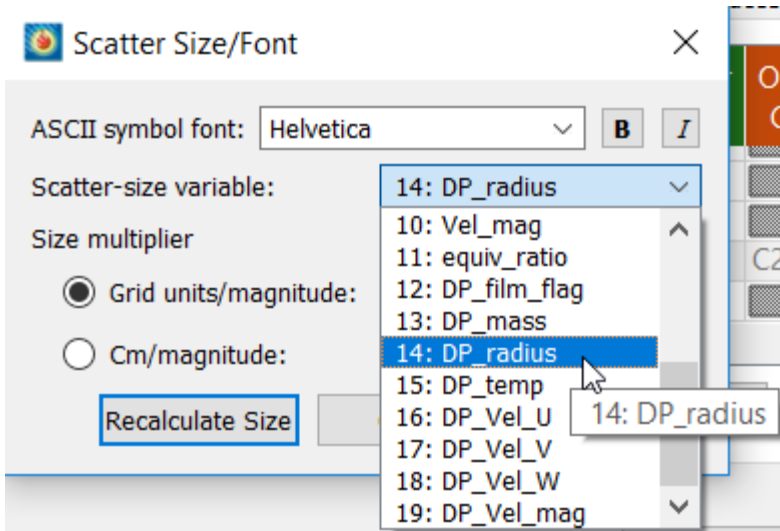

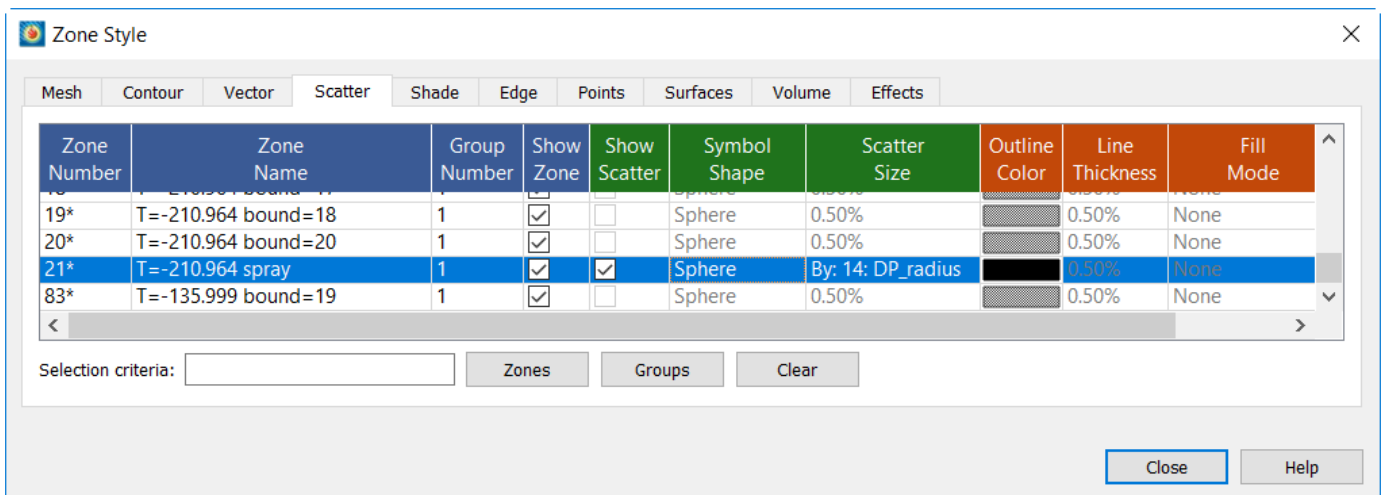

We want to have the Scatter symbols sized by their radius, from the scatter symbol variable dropdown menu, select the variable `DP_radius`. However the plot still hasn't updated yet. Finally right-click the symbol size dropdown menu again and select the `DP_radius` variable. Your Zone Style should look like this and the plot should show scatter spheres sized by radius.

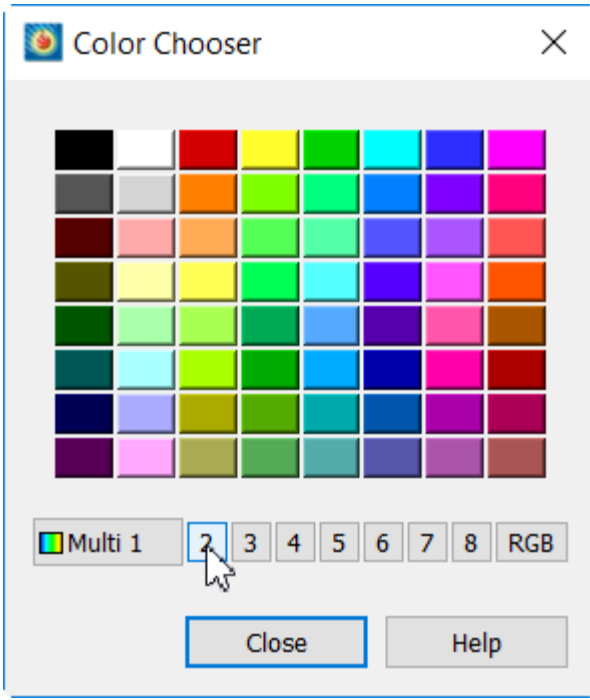

Step 5: Changing Spray Parcel Color

The spray has differing size but it still does not give us much information. Contouring the scatter symbols by temperature would be helpful. Open the Zone Style dialog again to the Scatter tab. Scroll down to the "Spray" zone and then scroll to the right to the Outline Color. Right-click the Outline Color and the Color Chooser menu will appear.



Select Multi 2. This corresponds to the Contour & Multi-Coloring group 2. To change the variable of group 2, we will go back to the Contour Details dialog accessed by the  button on the sidebar next to the Contour toggle. For the parcels, we want the color to be contoured by `DP_temp`. Now you can see how the parcels change temperature and size through time.

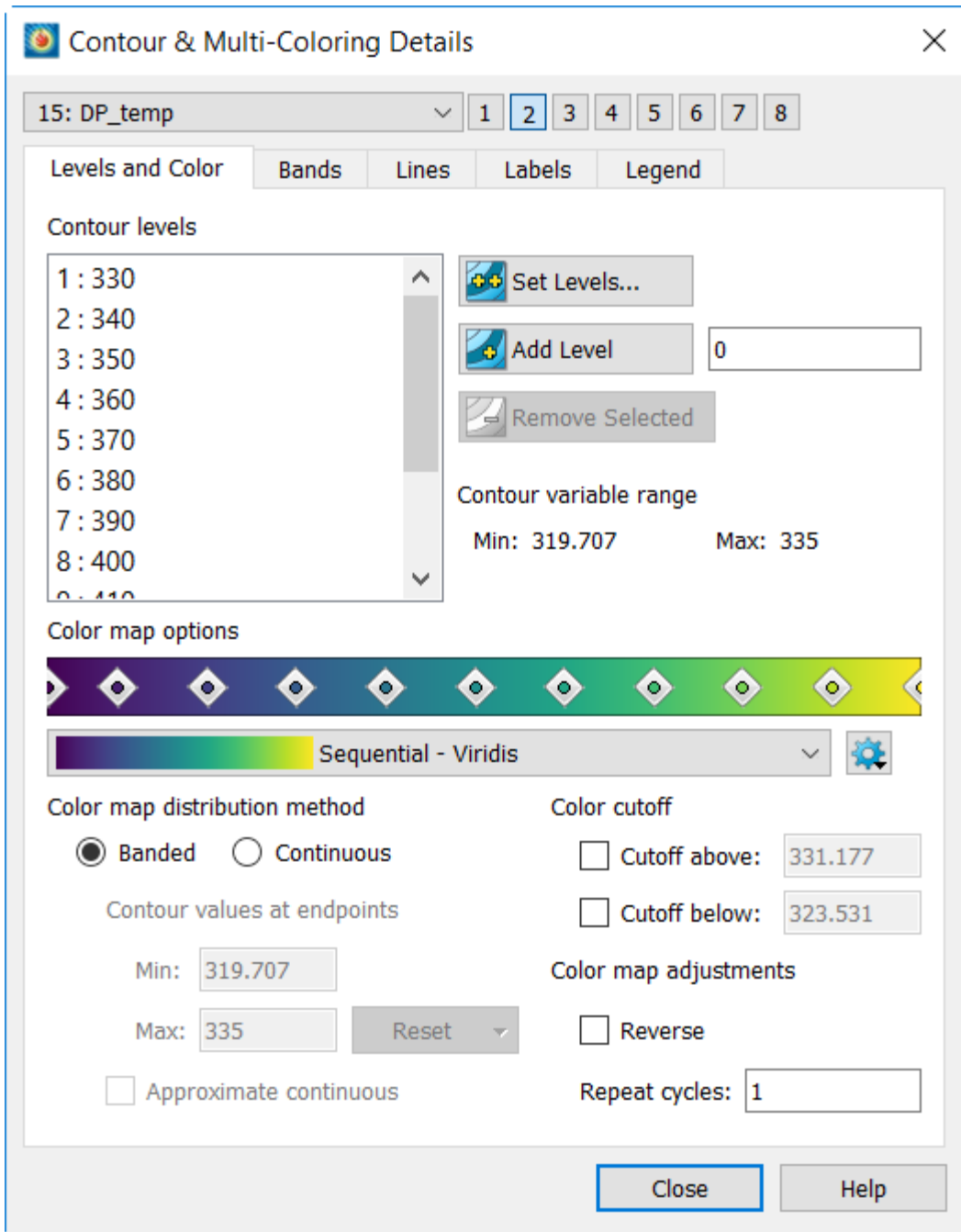

You'll notice after changing the Parcel color that two contour legends appear on screen. This is because the parcels are colored by `DP_temp` while the slice is contoured by `temp`. Since both contours are in reference to temperature, we can update the contour levels of both contour groups.

First remove the legend on contour group 2 by right-clicking the legend and selecting Hide. Then in the Levels and Color tab and select the Set Levels button. Enter the level information like below.

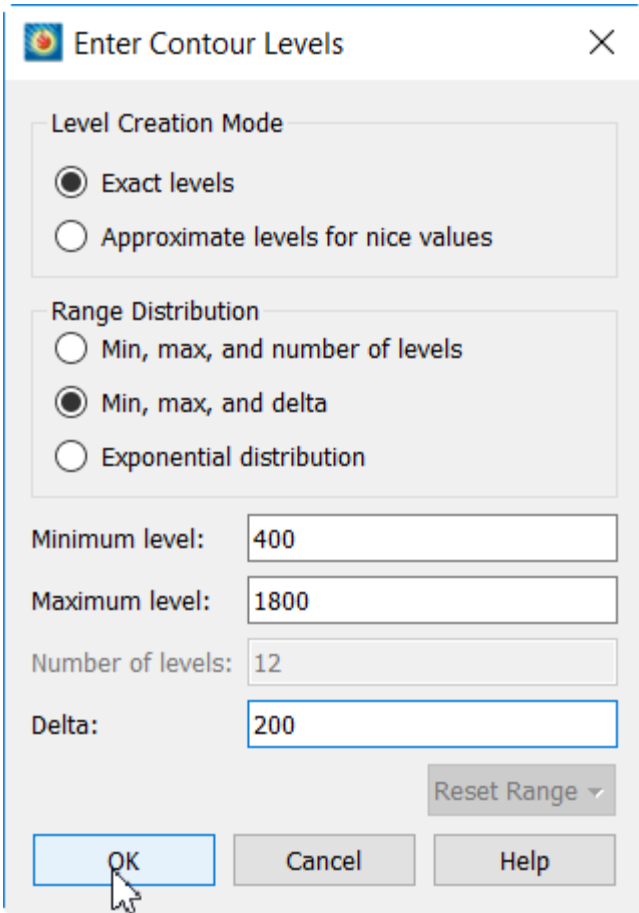

Now repeat with group 1. This will update `temp` and `DP_temp` to the same scale.



Spheres of Parcel spray can be graphically intensive for some systems. If that is the case, use Point shapes or circles. Points cannot be resized but can use colors much like Spheres.

Scenic Detour: Setting Default Scatter style in the Configuration File

If typical workflows include scatter on a single zone changing the default style can save many clicks.

These commands will change the default values for Scatter to "off" and the shape to "Point". This is especially helpful in situations like our example where we only want to turn on one zone's Scatter points. Note that color contours cannot be set in the configuration file.

The `tecplot.cfg` file, located in the installation folder, is able to set a default scatter shape and state for simplicity. Open the file in a text editor of your choosing and add the following lines to your configuration file:

```
#!/FieldMap Scatter{  
  Show = No  
  SymbolShape{GeomShape = Point}  
}
```

Step 6: Creating an Iso-surface

For this next step we will use iso-surfaces to visualize a flame front during the ignition phase of our engine. Be sure the slice created in steps 1 and 2 is turned off by unchecking Slices on the sidebar but keep the spray turned on, optionally, with the Point scatter shape. Your data should look something similar to this:

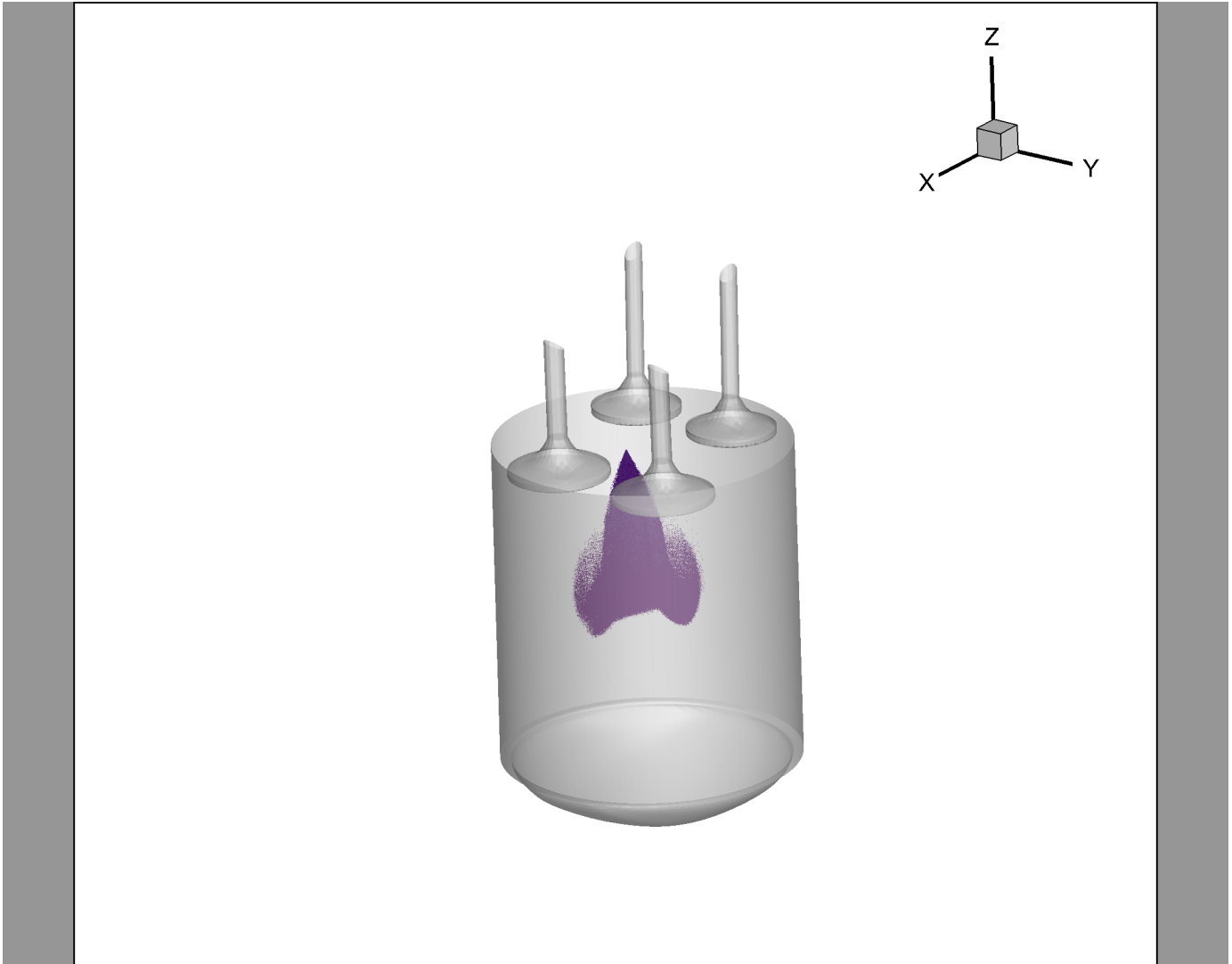

Next, we will turn on the Iso-surface option from the Plot sidebar. Select the checkbox next to "Iso-Surfaces" and then the  button (similar to how we opened the Slice details dialog). This will open the Iso-surface Details dialog.

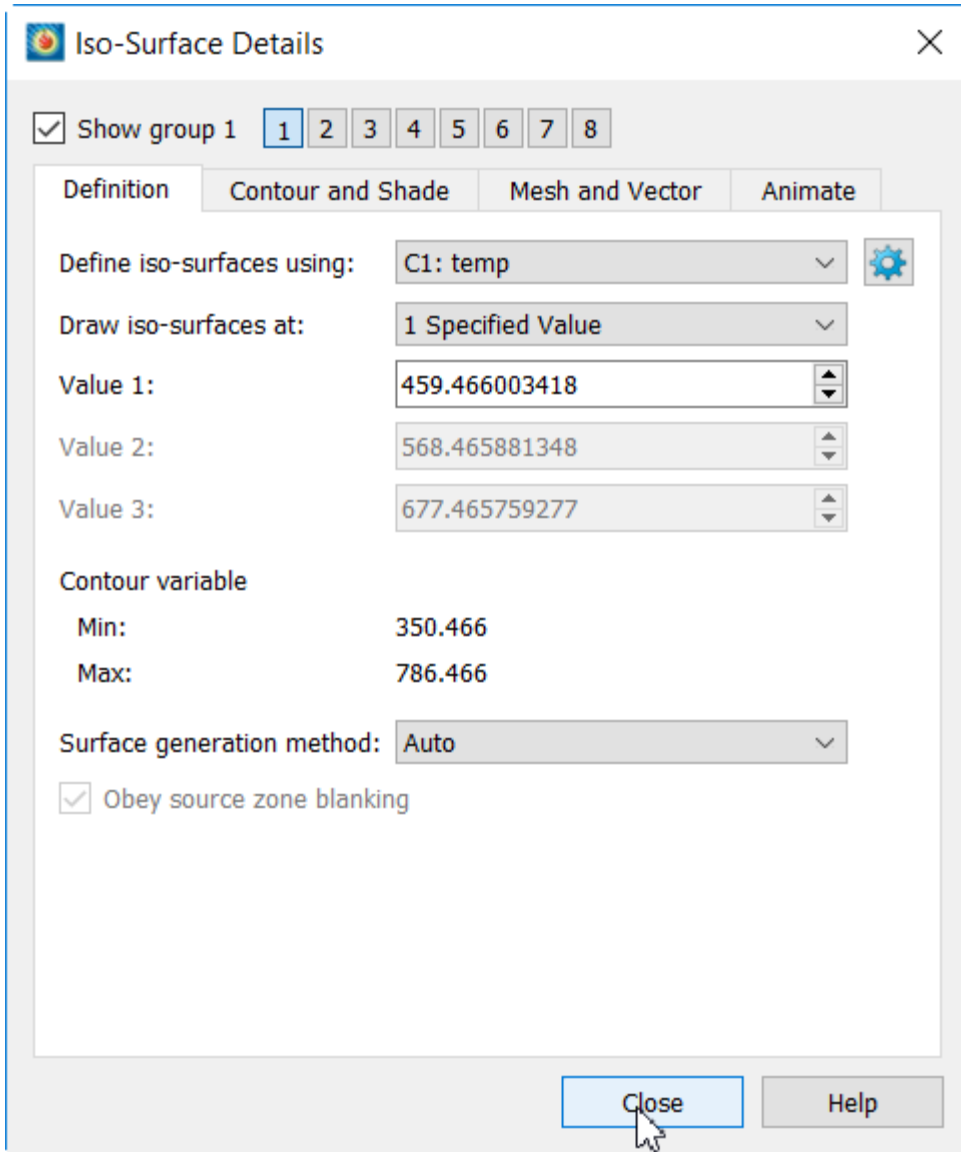

Since we want to visualize a flame front, use the variable `temp` set to Contour Group 1. Also select the Contour tab on the Iso-surface Details dialog and verify the Iso-surface is being contoured by `temp` as well.

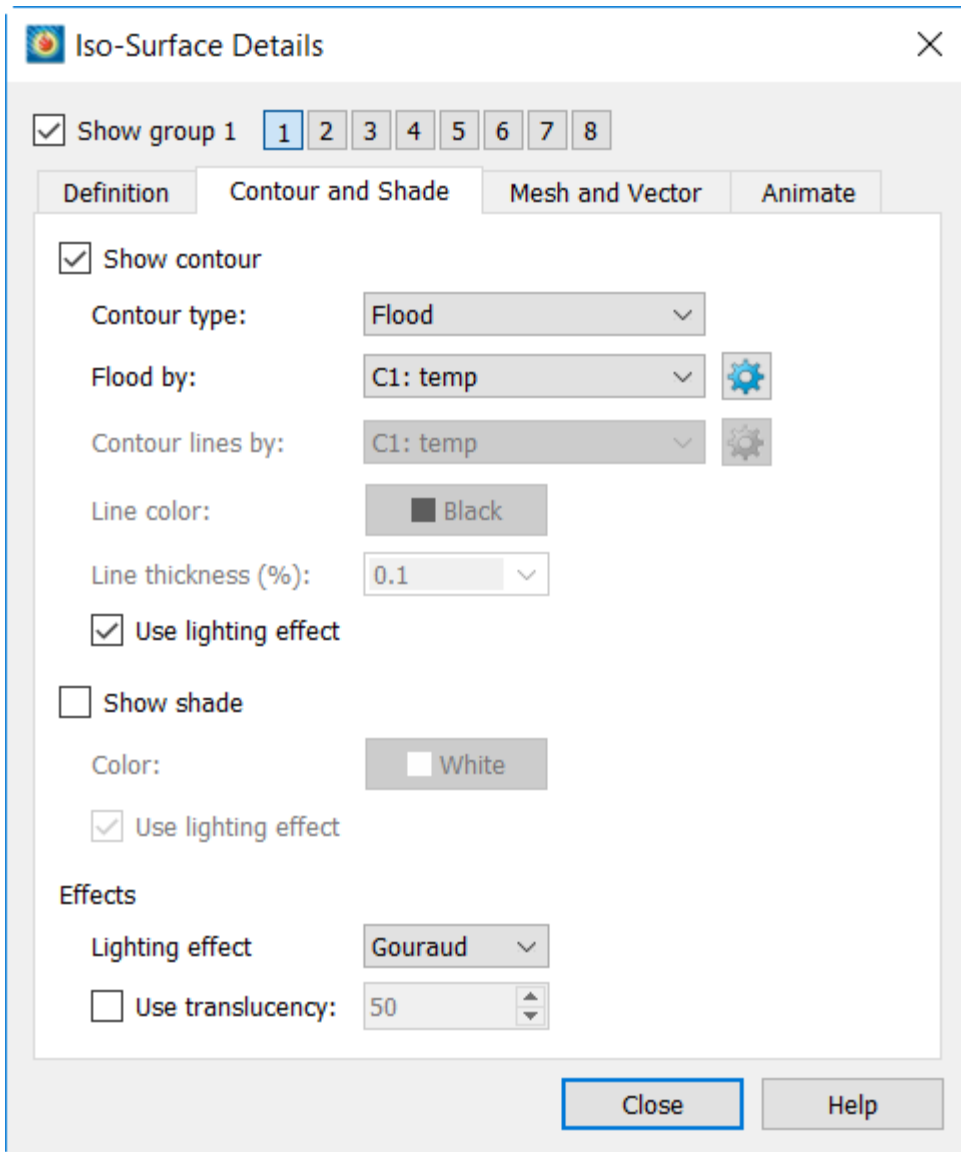

Back on the details page, set the value of the Iso-surface to be 2000, which represents the flame front.

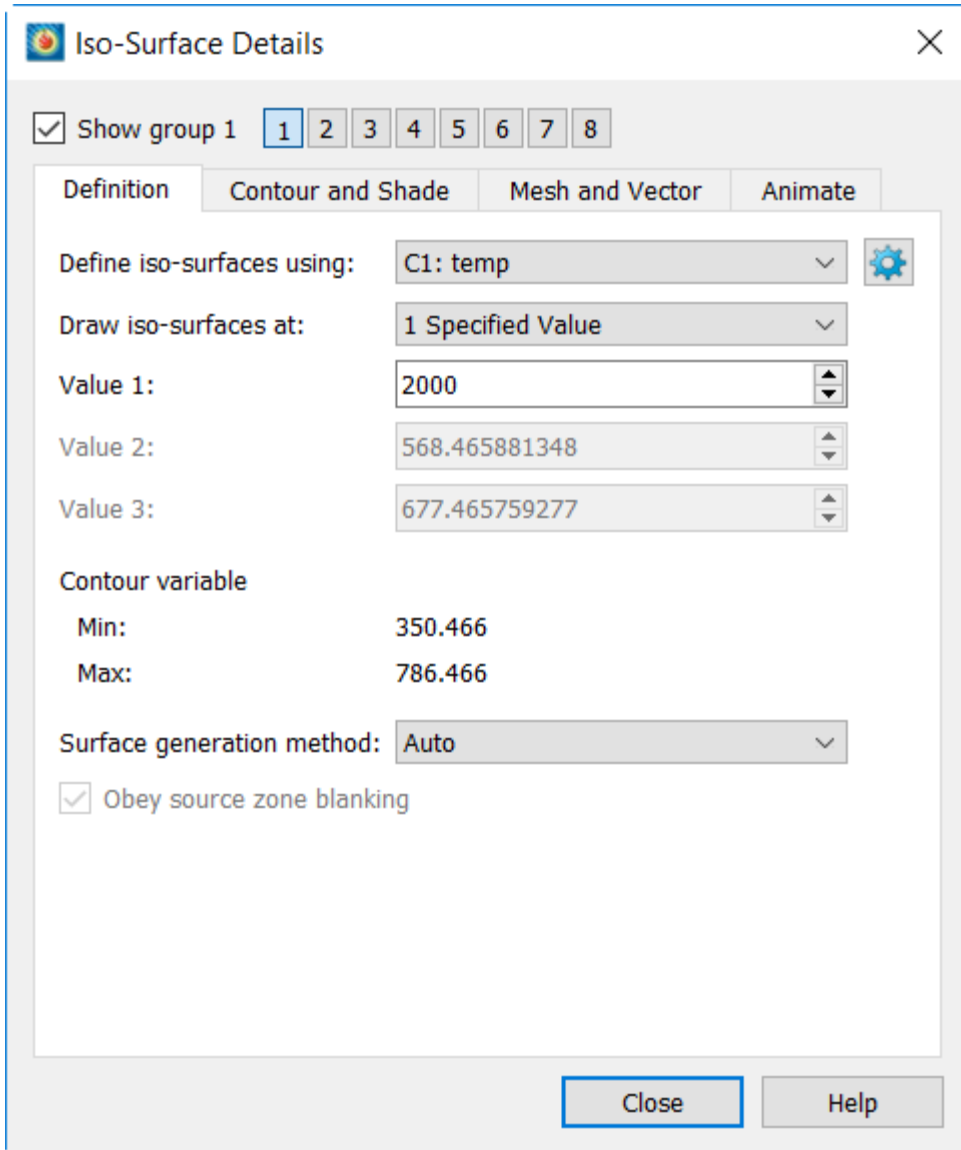

Pressing the play button on the Plot sidebar to animate through the flame front propagation.

Step 7: Using 3D Multi Frames

Our visualized data is starting to come together. However, it can be convenient to view data from multiple angles. This will give a better understanding of the data from all sides. This can be easily done by selecting **Frame** → **3D Multi Frames**. For this example, we will use the top-left option.

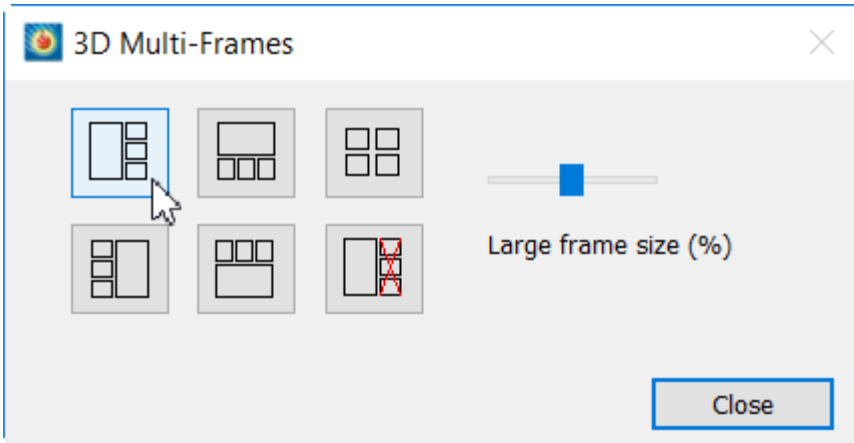

This will give us orthogonal views of our data set and we can derive a better understanding of our data throughout time.

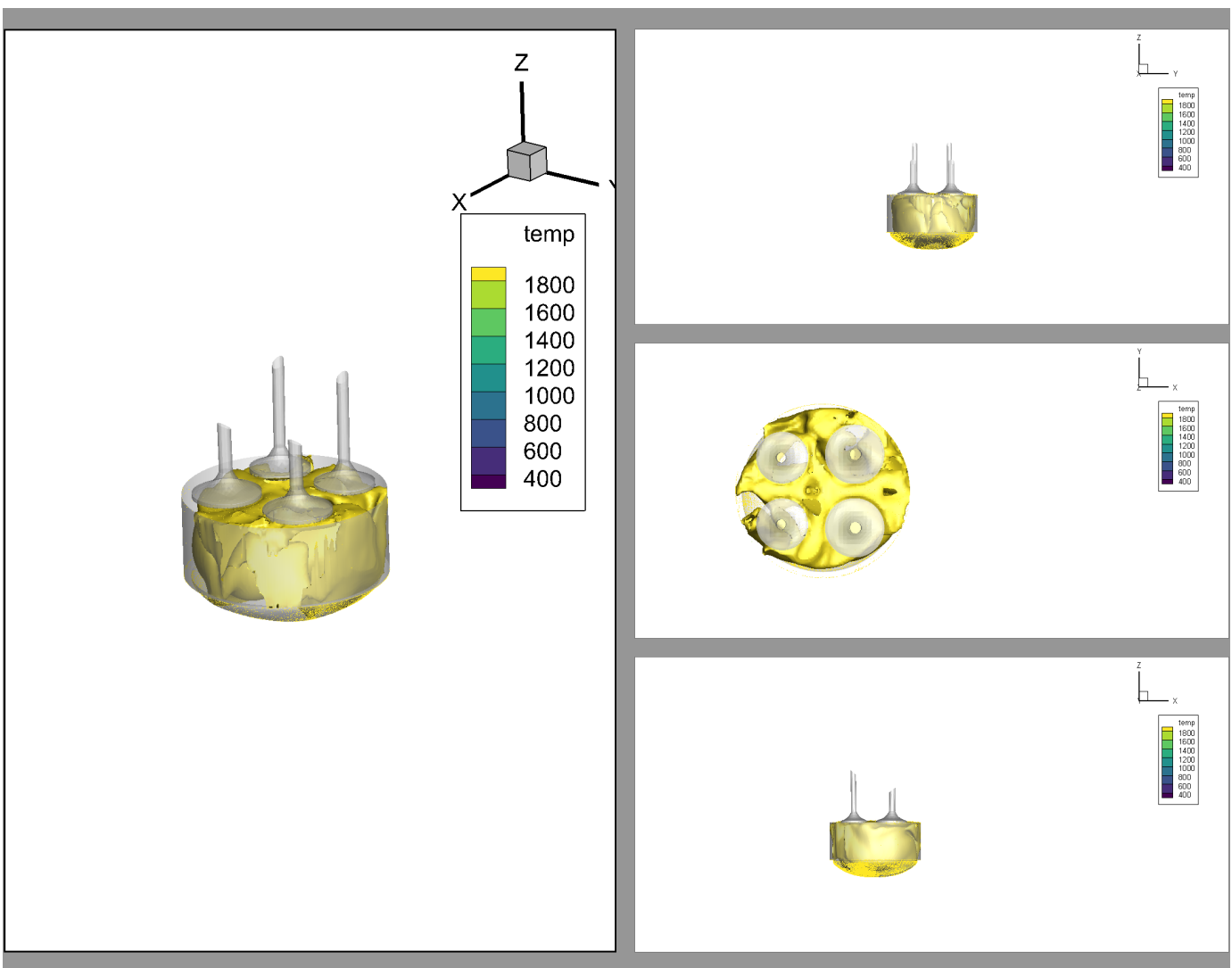

Step 8: Export to Movie File

Now that we have our plot set up as we want it, let's export our final product to a movie file. Select the  button next to the Solution Time to open the Time Animation Details dialog.

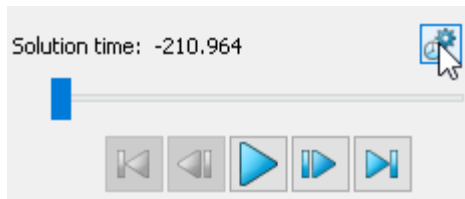

This dialog displays more advanced animation options than the Plot sidebar.

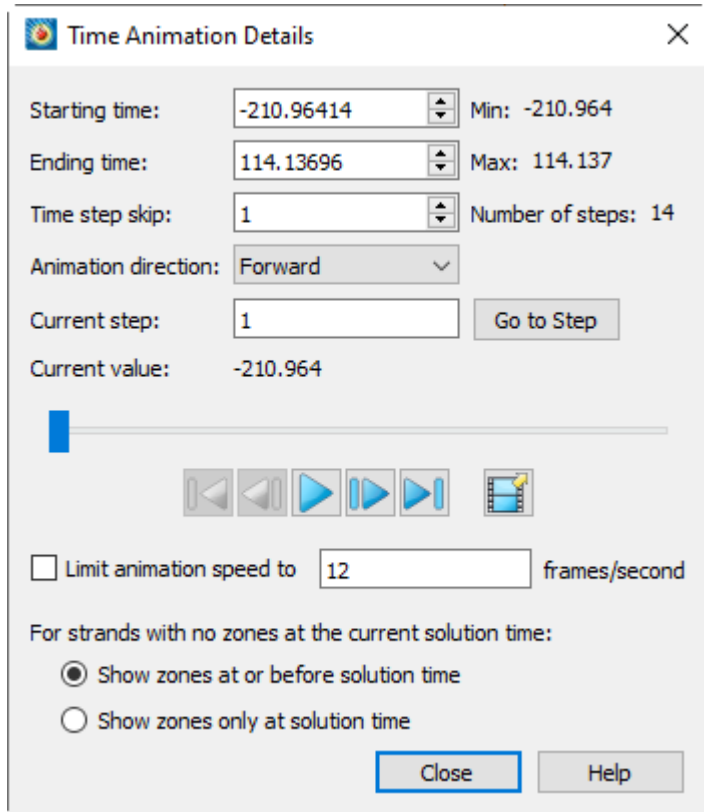

From the Time Animation details dialog, select the "Export to File" button next to the VCR buttons. This will open up the Animation Export dialog. The default animation export is MPEG-4. Because of the 3D Multi Frames in our workspace, ensure the region is "All Frames".

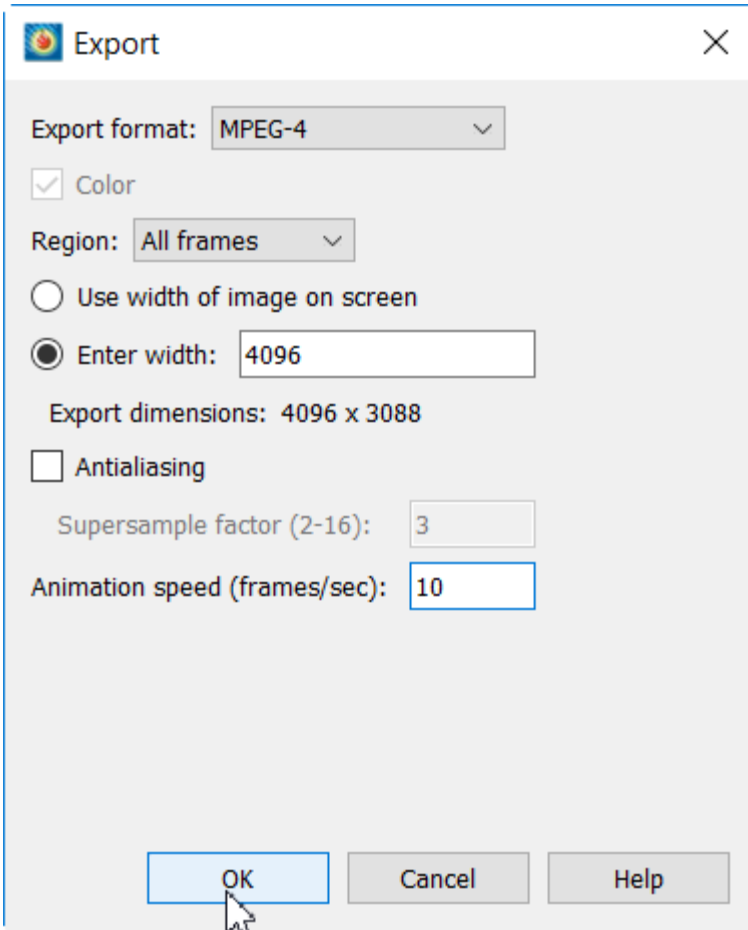

You can also choose to export a larger image width than your current view. This is especially helpful if the movie is going to be displayed on a high-resolution screen. For this example, we want our final product to be viewed on a 4K resolution display so we will enter a width of 4096. Select OK and save the final file.

Loading Cell Averaged Output Files (CONVERGE)

This section will use data time history exported from CONVERGE. Although somewhat specific to CONVERGE users, it will show general time history capabilities. If you are continuing from the previous segment, select **File > New Layout** to clear the previous plot.

Step 1: Loading the data

Load `area_avg_flow.out` from the ICE directory of the Getting Started Guide Bundle. Select **File > Load Data**. Once prompted, select the CONVERGE Output Loader.

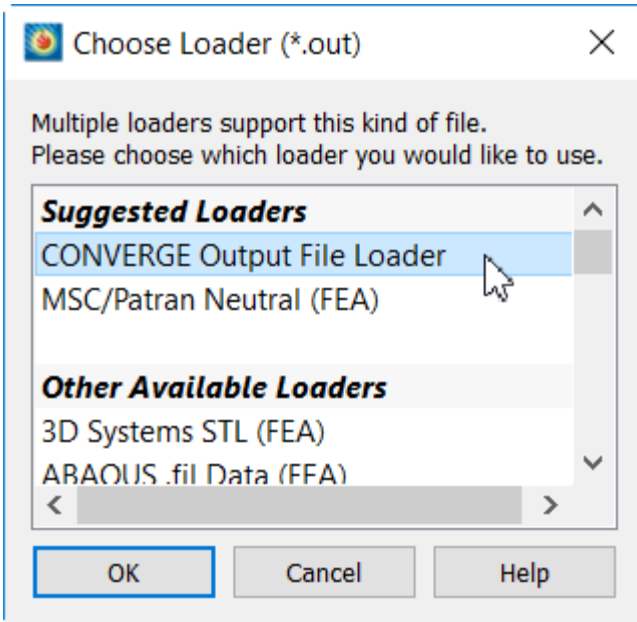

Selecting **OK** will load the plot in **XY Line** type.

Step 2: Add Multiple Y Axes

The plot by default is in XY Line mode which contains pre-loaded XY Line maps. Select the Mapping Style button on the Plot Sidebar to see which Mappings are available. You can see that this file was loaded with many variables premade vs. the **Crank Angle**. For this example, change the plot to show **Avg_Temp** and **Mass_Flow_Rate** by **Crank Angle**. Turn off the default map for **Crank vs Cycle Number**. Turn on Map numbers 2 and 5.

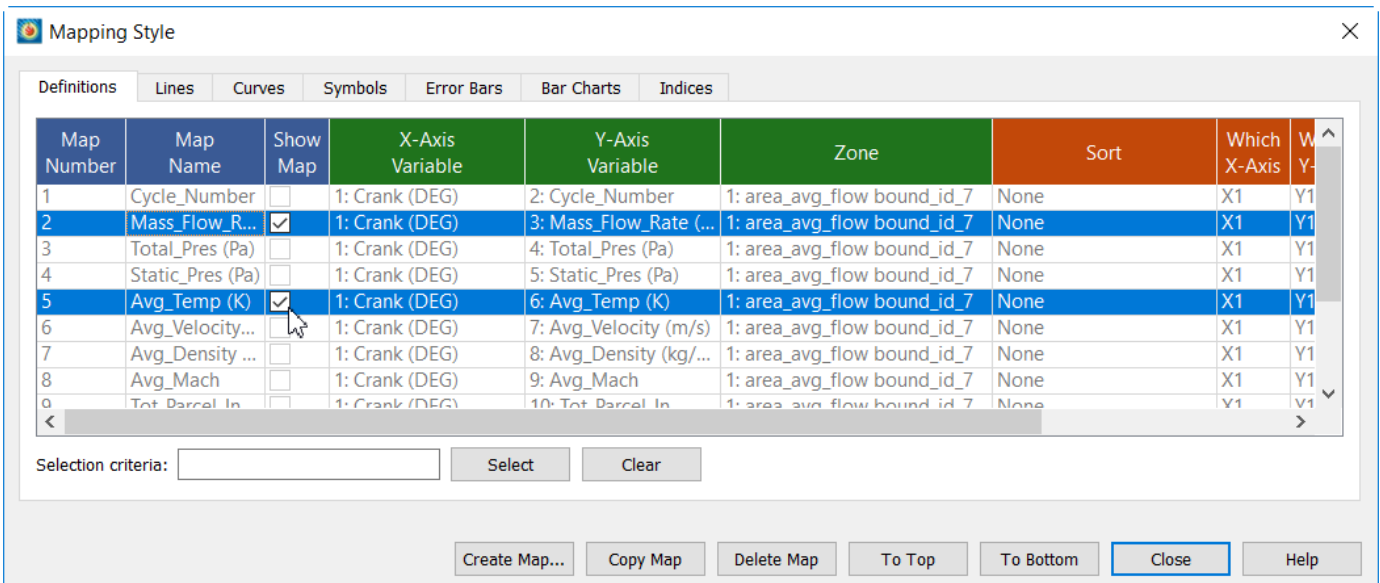

Notice how the plot automatically merges both lines to one Y Axis. The min/max values of **Mass_Flow_Rate** and **Avg_Temp** are very different, so putting one of the mappings in a second Y axis will help.

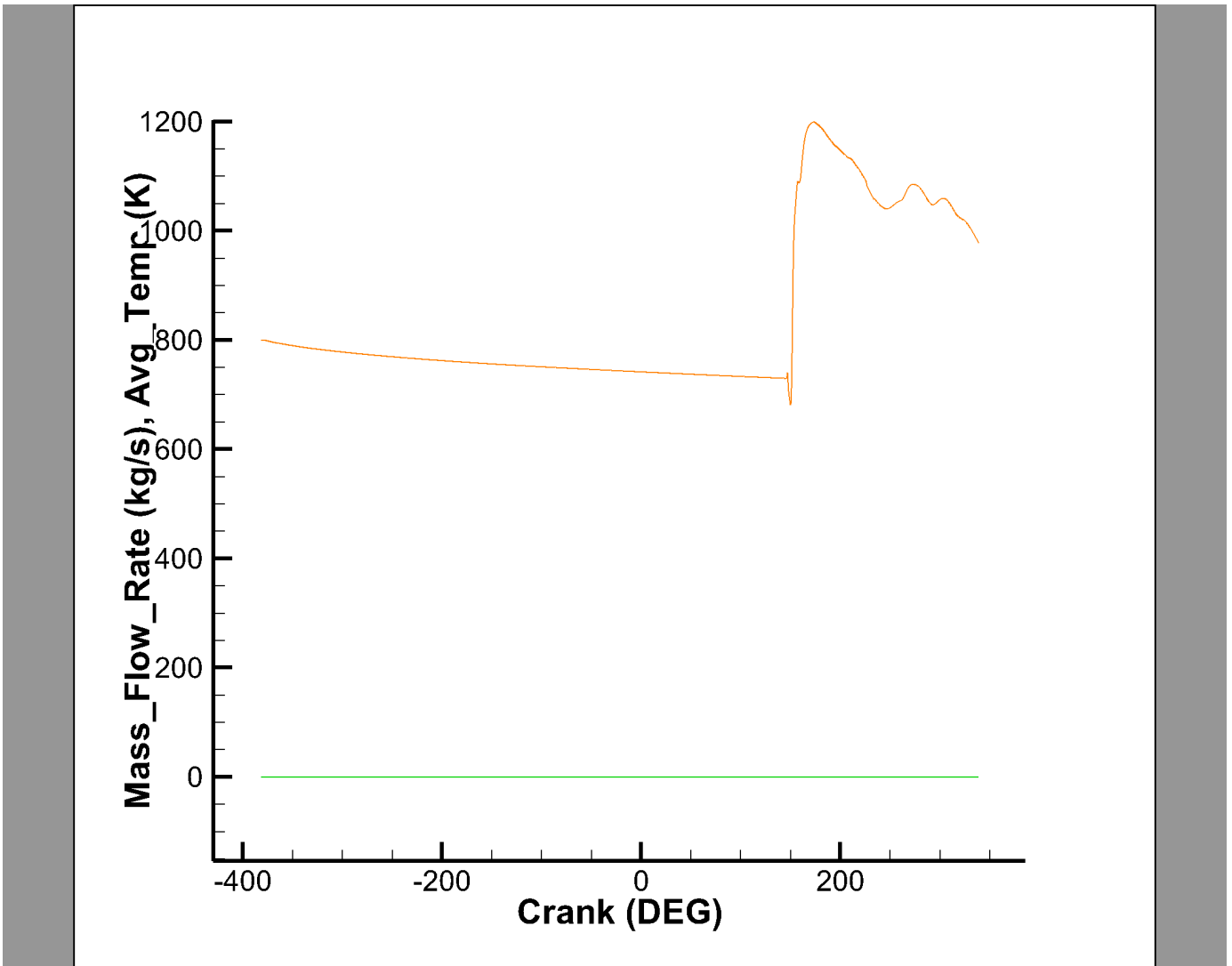

Select the Mapping Style button again on the Plot Sidebar. Scroll to the right to the "Which Y-Axis" column and right click the *Avg_Temp* row. Then select Y2 as the Y-Axis. The plot will automatically update.

Mapping Style



Definitions Lines Curves Symbols Error Bars Bar Charts Indices

Map Name	Show Map	X-Axis Variable	Y-Axis Variable	Zone	Sort	Which X-Axis	Which Y-Axis	Show in Legend
Cycle_Number	<input type="checkbox"/>	1: Crank (DEG)	2: Cycle_Number	1: area_avg_flow bound_id_7	None	X1	Y1	Auto
Mass_Flow_Rate (kg/s)	<input checked="" type="checkbox"/>	1: Crank (DEG)	3: Mass_Flow_Rate (kg/s)	1: area_avg_flow bound_id_7	None	X1	Y1	Auto
Total_Pres (Pa)	<input type="checkbox"/>	1: Crank (DEG)	4: Total_Pres (Pa)	1: area_avg_flow bound_id_7	None	X1	Y1	Auto
Static_Pres (Pa)	<input type="checkbox"/>	1: Crank (DEG)	5: Static_Pres (Pa)	1: area_avg_flow bound_id_7	None	X1	Y1	Auto
Avg_Temp (K)	<input checked="" type="checkbox"/>	1: Crank (DEG)	6: Avg_Temp (K)	1: area_avg_flow bound_id_7	None	X1	Y1	Auto
Avg_Velocity (m/s)	<input type="checkbox"/>	1: Crank (DEG)	7: Avg_Velocity (m/s)	1: area_avg_flow bound_id_7	None	X1	Y1	Auto
Avg_Density (kg/m³)	<input type="checkbox"/>	1: Crank (DEG)	8: Avg_Density (kg/m³)	1: area_avg_flow bound_id_7	None	X1	Y1	Auto
Avg_Mach	<input type="checkbox"/>	1: Crank (DEG)	9: Avg_Mach	1: area_avg_flow bound_id_7	None	X1	Y1	Auto
Total_Pres (Pa)	<input type="checkbox"/>	1: Crank (DEG)	10: Total_Pres (Pa)	1: area_avg_flow bound_id_7	None	Y1	Y1	Auto

Selection criteria:

Finally close the Mapping Style dialog to see the final plot. If your plot doesn't automatically update to the new axis bounds, select Ctrl+F (or use **View > Fit to Full Size**).

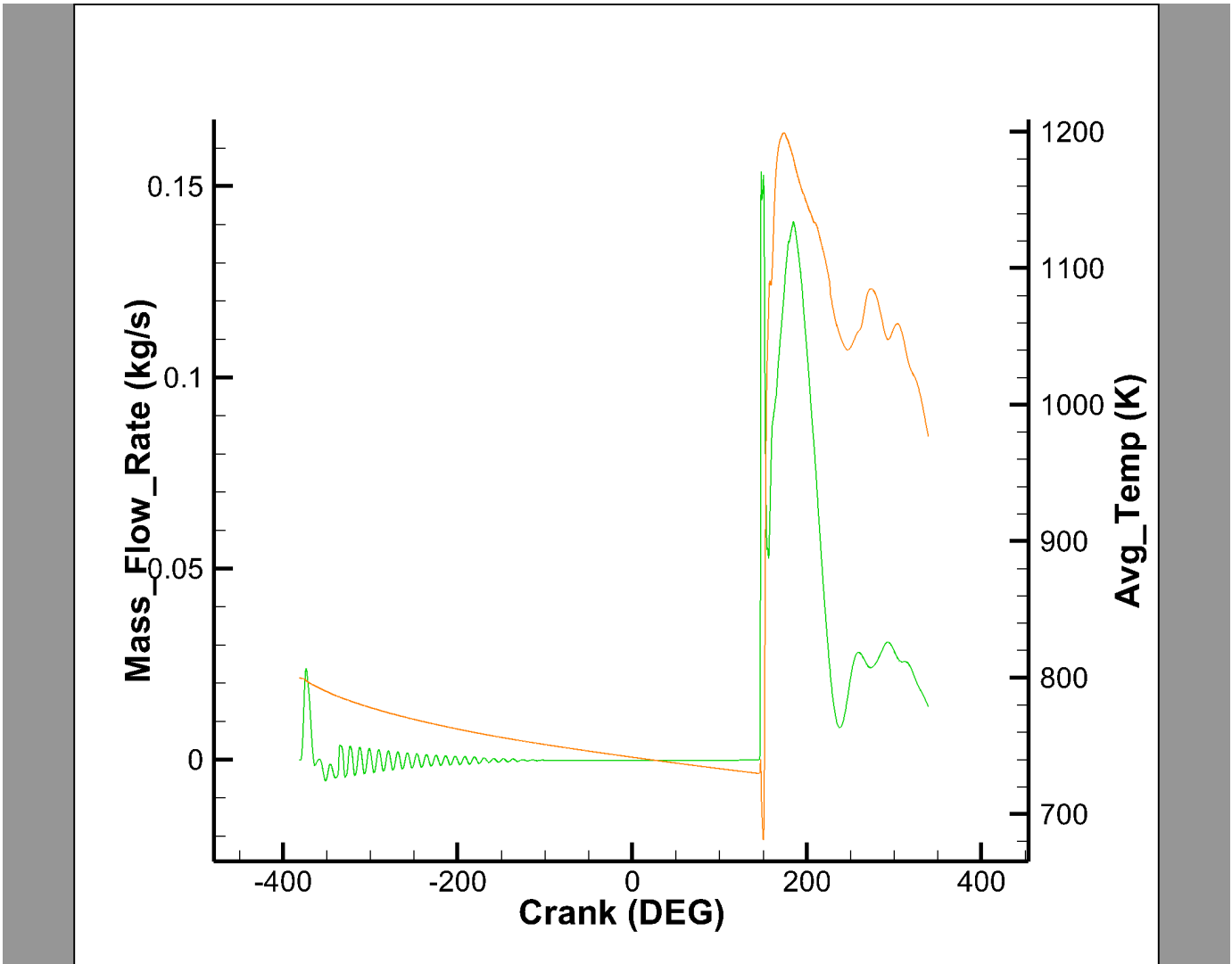

To increase the line thickness, right-click the line to bring up the right-click context menu and update the the thickness as desired. For black and white printing, consider changing one of the lines to dashed.

Step 3: Add Grid Lines

Select **Plot > Axis** to open the **Axis Details** menu (or double click on the axis). From the Axis Details menu, you can see the different tabs to update the plot axes. Notice the **X1, Y1, X2 ...** buttons, these control the axis being acted on. For now, we want to update the X1 Grid Lines. Select the Grid tab to update the grid lines for the X1 axis. Select the Y1 button as well to update the Grid options for Y1. In our case, Y1 is the **Mass_Flow_Rate**.

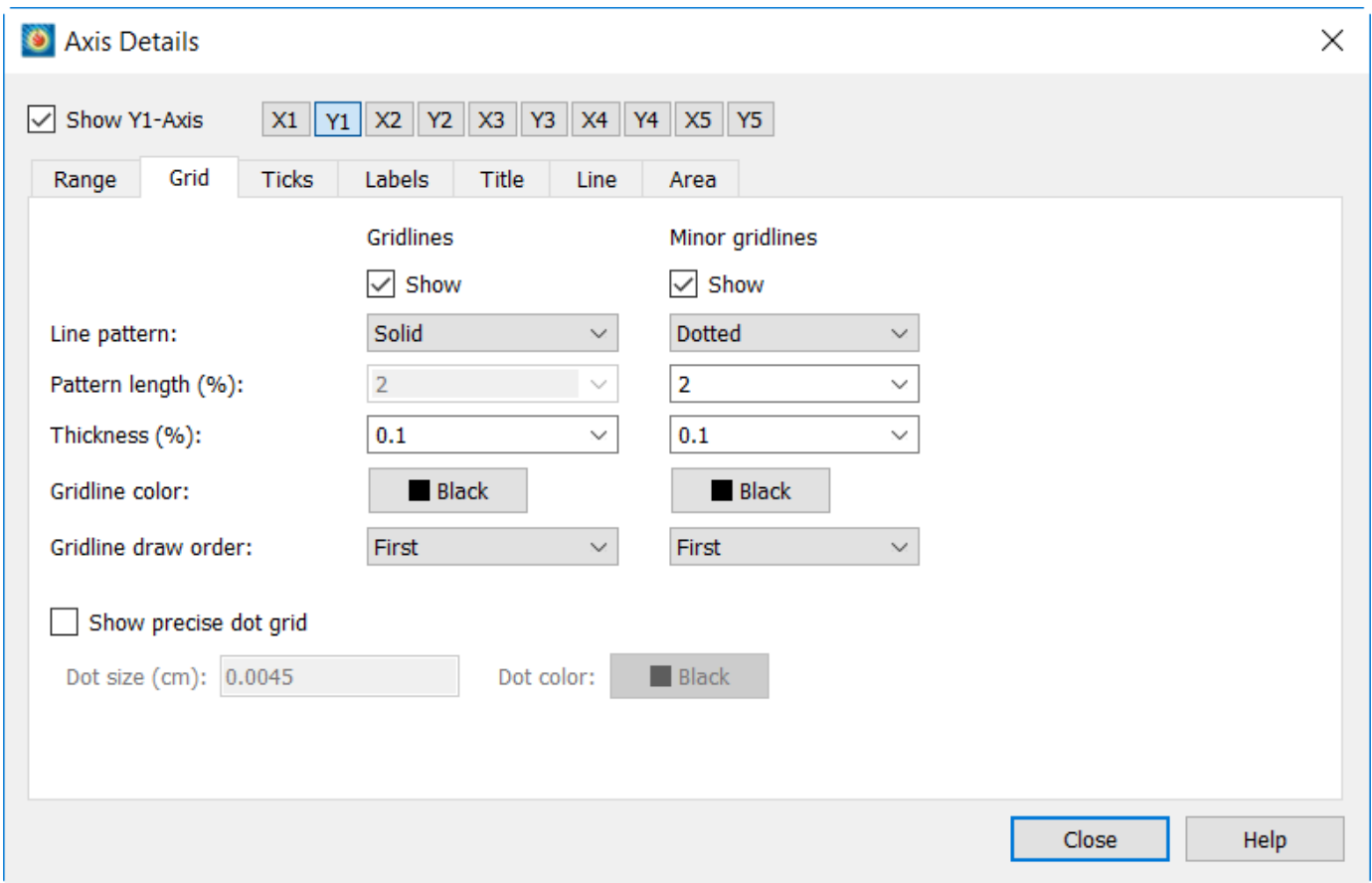

Select the Show checkboxes under Gridlines and Minor Grid Lines. Notice how the Major Tick labels have the Solid gridlines and the Minor Tick labels have the Dotted Gridlines.

Next select the Y2 button to edit the Grid Lines for Avg_Temp. Like before, show the Gridlines but this time leave the Minor Gridlines off. Also notice that there are no distinguishing differences between the major gridlines. For that reason, we want to update the Gridlines color to "Blue".

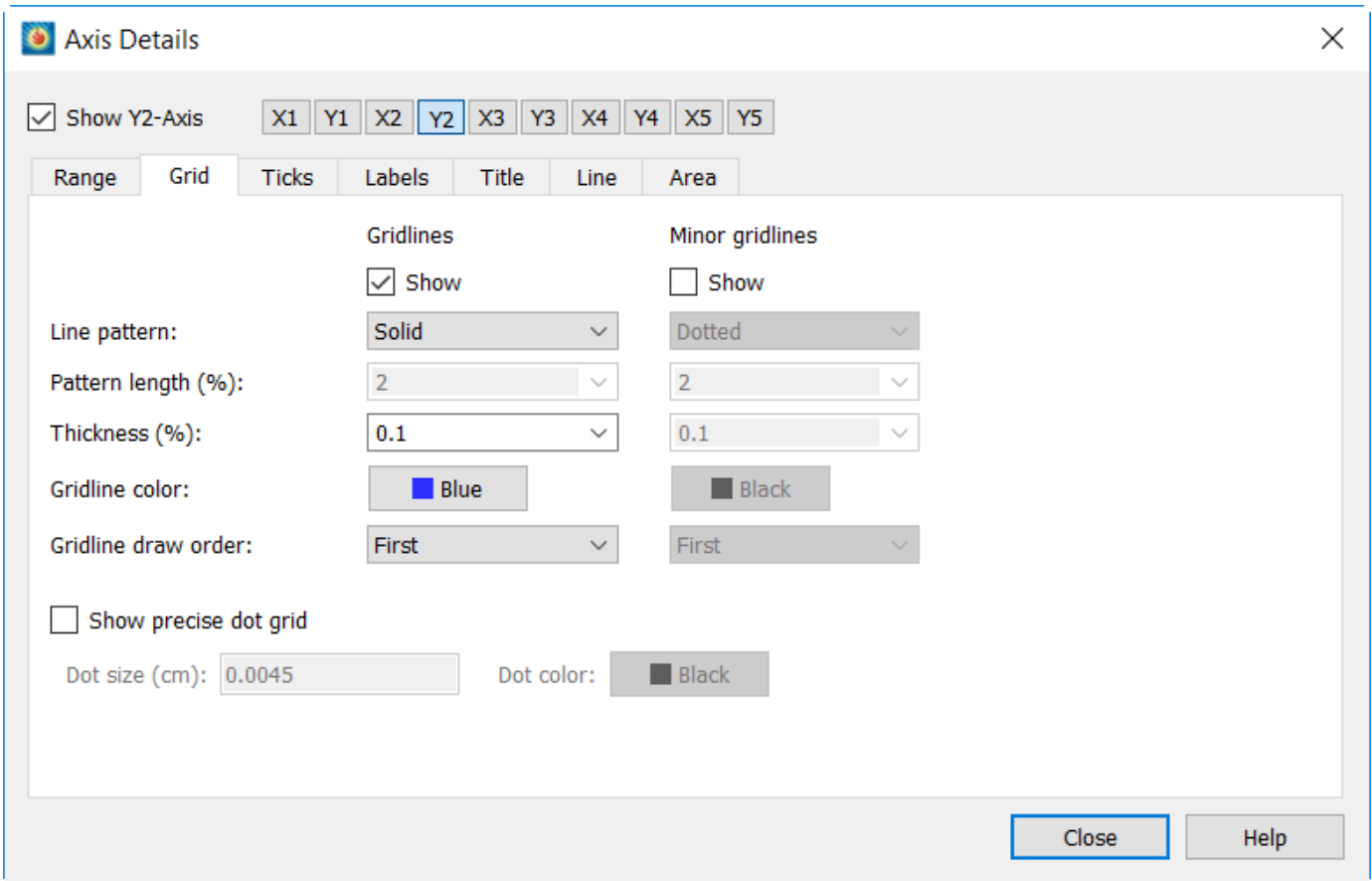

Step 4: Update Axis Labels

Next, we want to update the Axis Labels to be spaced more cleanly. For *Avg_Temp*, the axis labels are spaced well with 100 points between each step so Y2 will not need to be updated. However, we will update Y1 to a better distribution. From the Axis Details dialog select the Labels tab.

Deselect the Auto Spacing option at the bottom to give us control of the Label Spacing. Then in the Spacing field, update the number to 0.025. Close the Axis Details dialog.

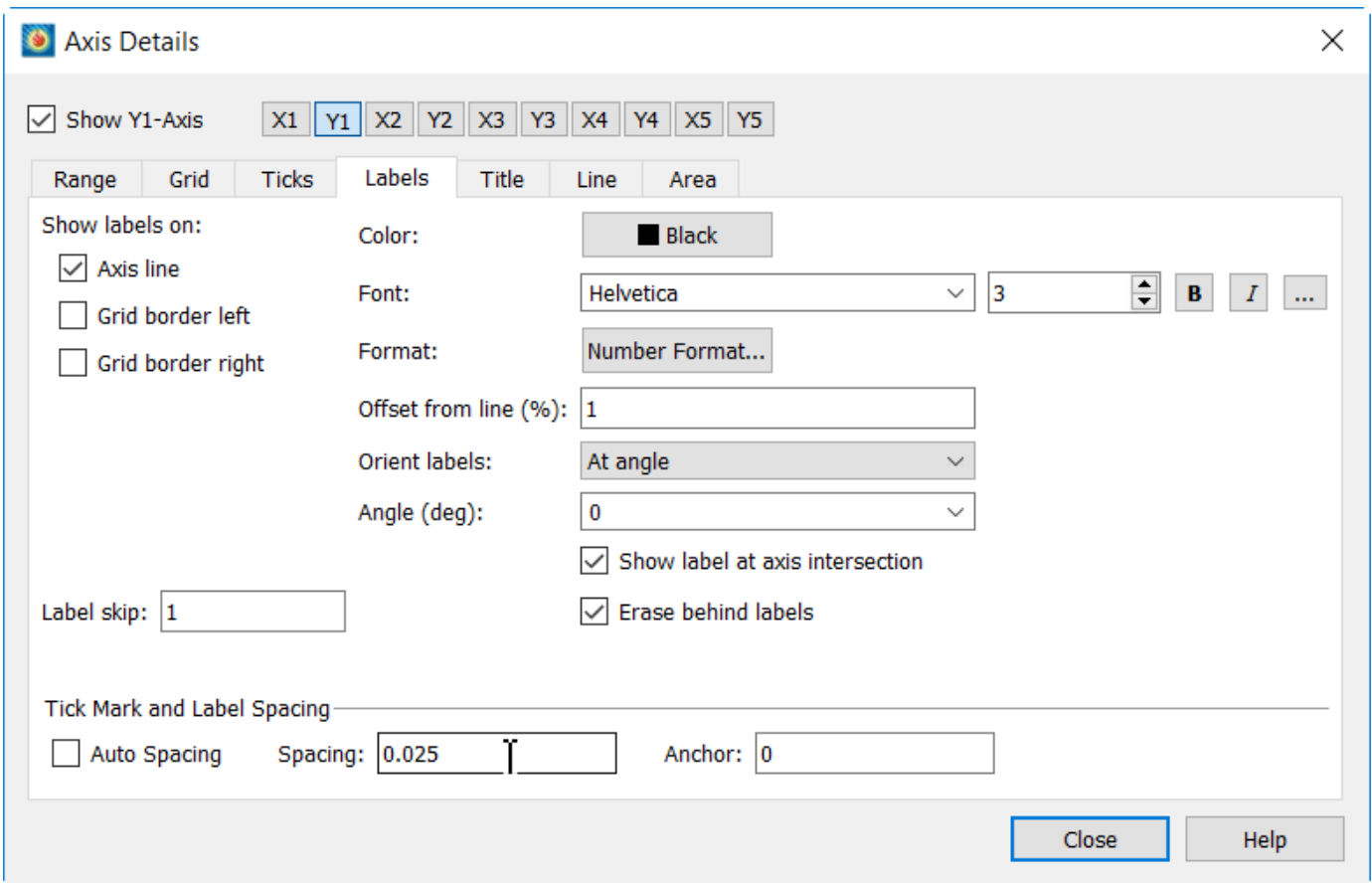

The final plot is shown below:

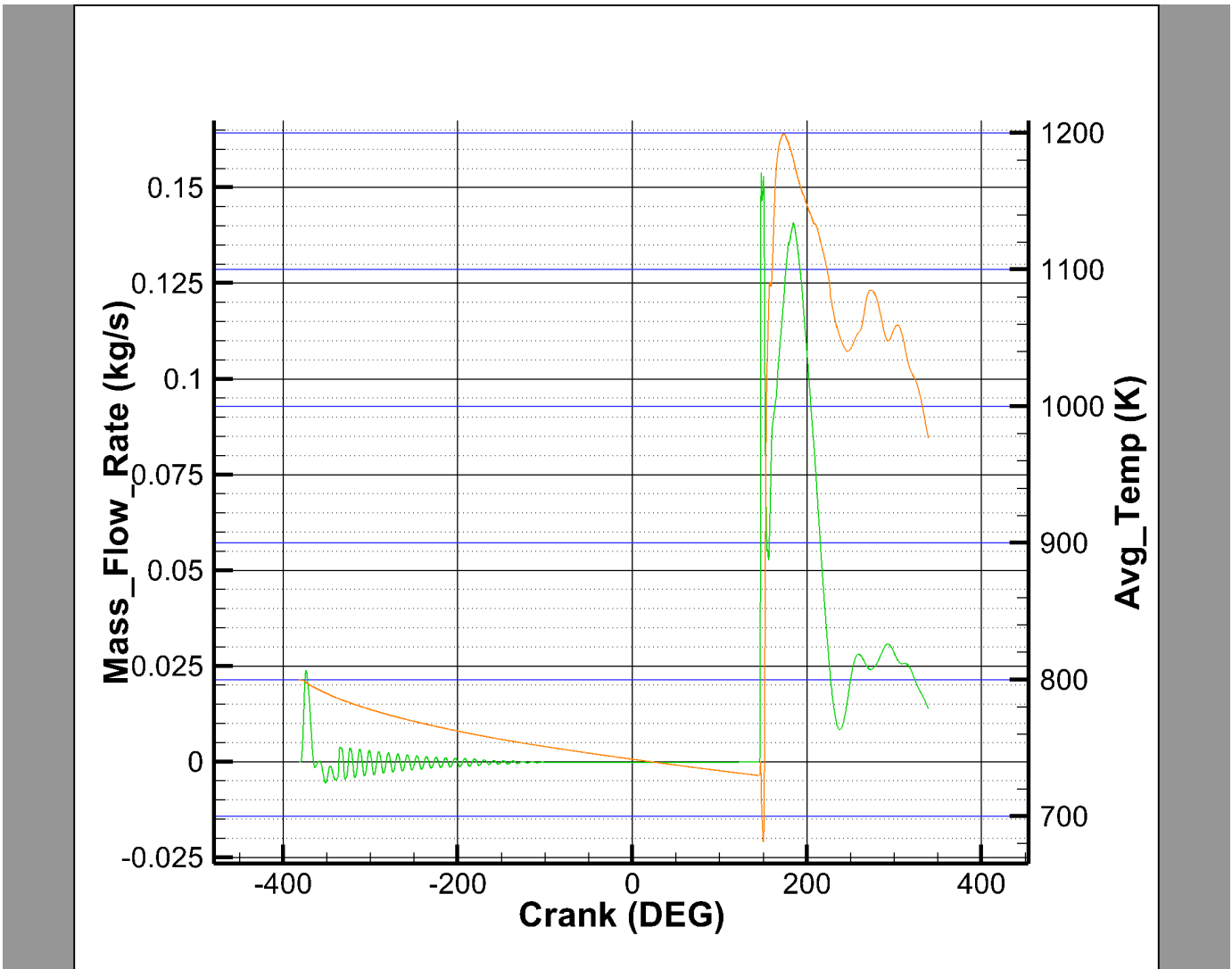

Next Steps

This concludes the Internal Combustion Engine tutorial for Tecplot 360. At this point, you may wish to dig in to the User's Manual or Help (**Help>Tecplot 360 Help**) for more details on the product in general or on specific features you've used in this tutorial.

We regularly create videos to introduce users to features of the product, not just introductory topics for new users, but also for advanced users and to highlight new features in the latest release. You can find these on our Web site at www.tecplot.com/category/tecplot-360-videos/?product=360 or on our YouTube channel at www.youtube.com/user/tecplot360.

Part 3: Ocean Modeling

Ocean Modeling

This tutorial uses a transient FVCOM NetCDF data set of the Boston harbor. The data may be downloaded from the [Getting Started Bundle](#).

This data set was provided by UMASS Chen's lab. The original data is located [here](#).

The FVCOM NetCDF data file must have *nv* (element to node connectivity), *siglev* (sigma level), *h* (depth), *zeta* (surface elevation), (*lon,lat*) or (*x, y*) coordinates for Tecplot 360 to be able to load. Tecplot 360 is not able to deal with FVCOM NetCDF data without the above variables.

The overall difficulty, description, and features used in each segment are shown below:

Number and Level	Title and Description	Features Used
1 - <i>Beginner</i>	Loading and Manipulating Data - Load the Boston example dataset and inspect the data.	<ul style="list-style-type: none">• Data Loading• Data Set Information
2 - <i>Intermediate</i>	Making your first plot - Adding plot styling and value blanking to create an animation plot and exporting to a movie file.	<ul style="list-style-type: none">• Contours• Zone Style• Axis Scaling• Value Blanking
3 - <i>Intermediate</i>	Specific Ocean Plots - Visualize surface vector fields, insert a georeferenced image and show iso-surfaces.	<ul style="list-style-type: none">• Visualizing Surface Velocities• Insert a Georeferenced Image• Understanding Salinity Stratification
4 - <i>Advanced</i>	Advanced Topics - Links to advanced topics available on the Tecplot website.	<ul style="list-style-type: none">• PyTecplot• Averages• Shapefiles

Loading and Manipulating Data

Step 1: Launch Tecplot 360 and Load the Data Set

Start Tecplot 360 from the Start menu (Windows), by typing `tec360` in a terminal window (Linux), or by double-clicking the application icon in the Applications folder (Mac). The Tecplot 360 Welcome Screen appears, as shown here. (We will show the Windows version of Tecplot 360 in this document, but the product looks substantially the same on other platforms).

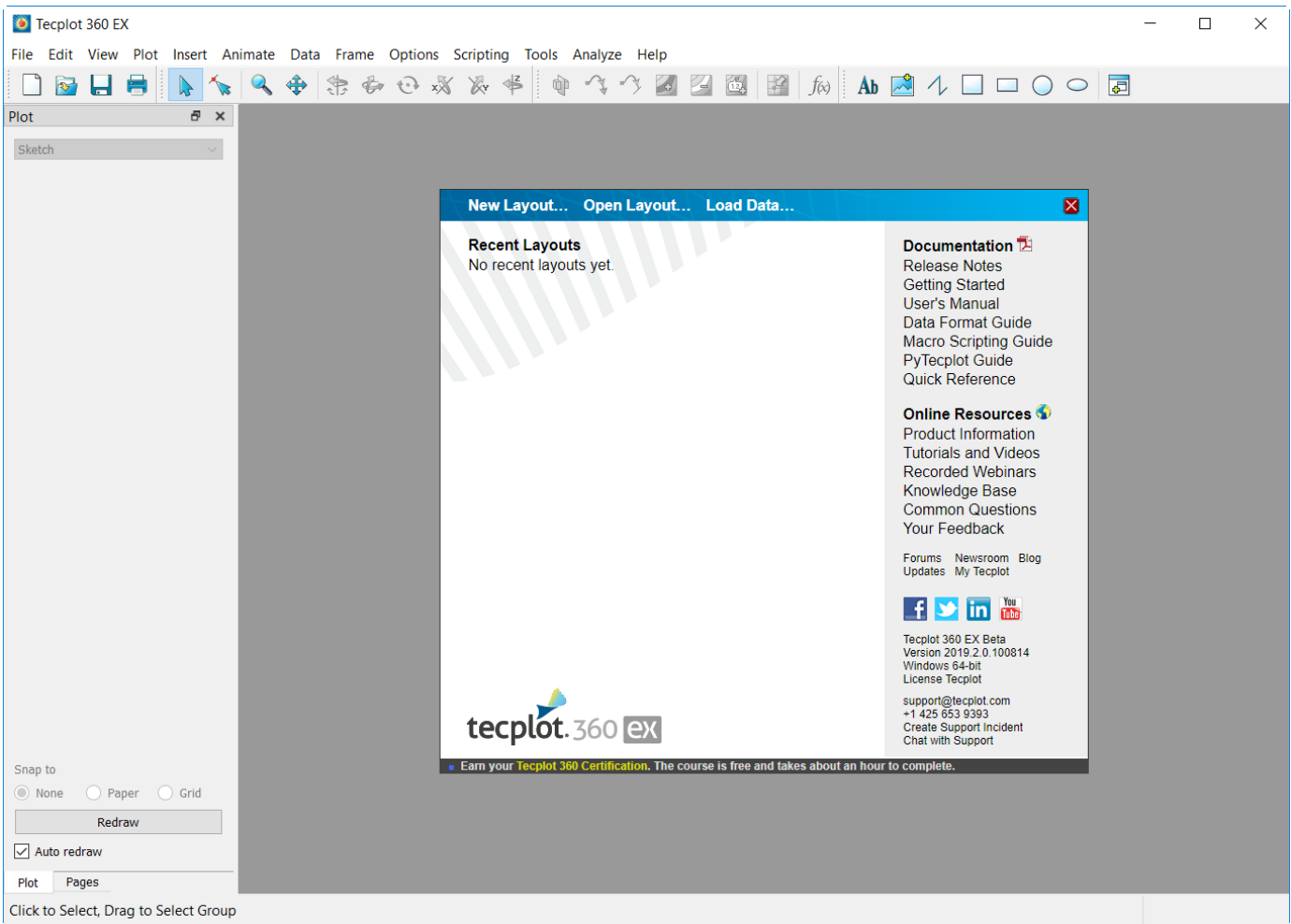

The Welcome Screen appears each time you launch Tecplot 360 and gives you easy access to layouts you have recently worked with, along with quick links to documentation and other resources to help you get the most out of the product.

To begin loading the data, click Load Data at the top of the Welcome Screen. (You may also choose Load Data from the File drop-down menu in the menu bar, or click the folder icon, second from the left, in the toolbar. These alternate methods are convenient when the Welcome Screen isn't visible).

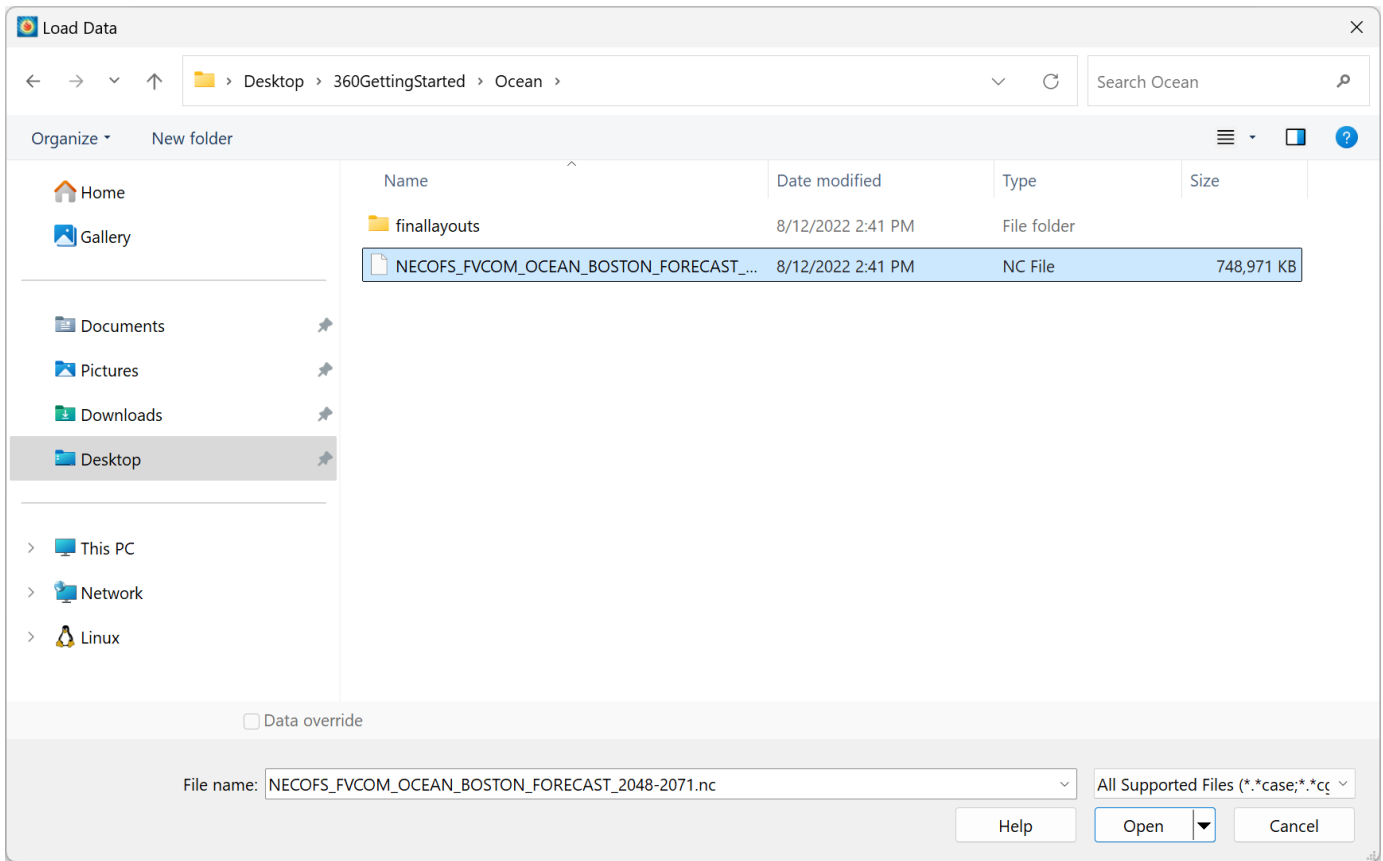

Navigate to your Tecplot 360 Getting Started Bundle folder and then the Ocean folder. Highlight the .nc file and select Open to open it in Tecplot 360. (If you can't see this file, choose All Files in the menu at the bottom of the dialog.) The data file is opened and a 3D plot of the Boston harbor loads in the Tecplot 360 workspace, as shown here, an orange box shows the bounds of the volume data. See [Understanding Volume Surfaces](#).

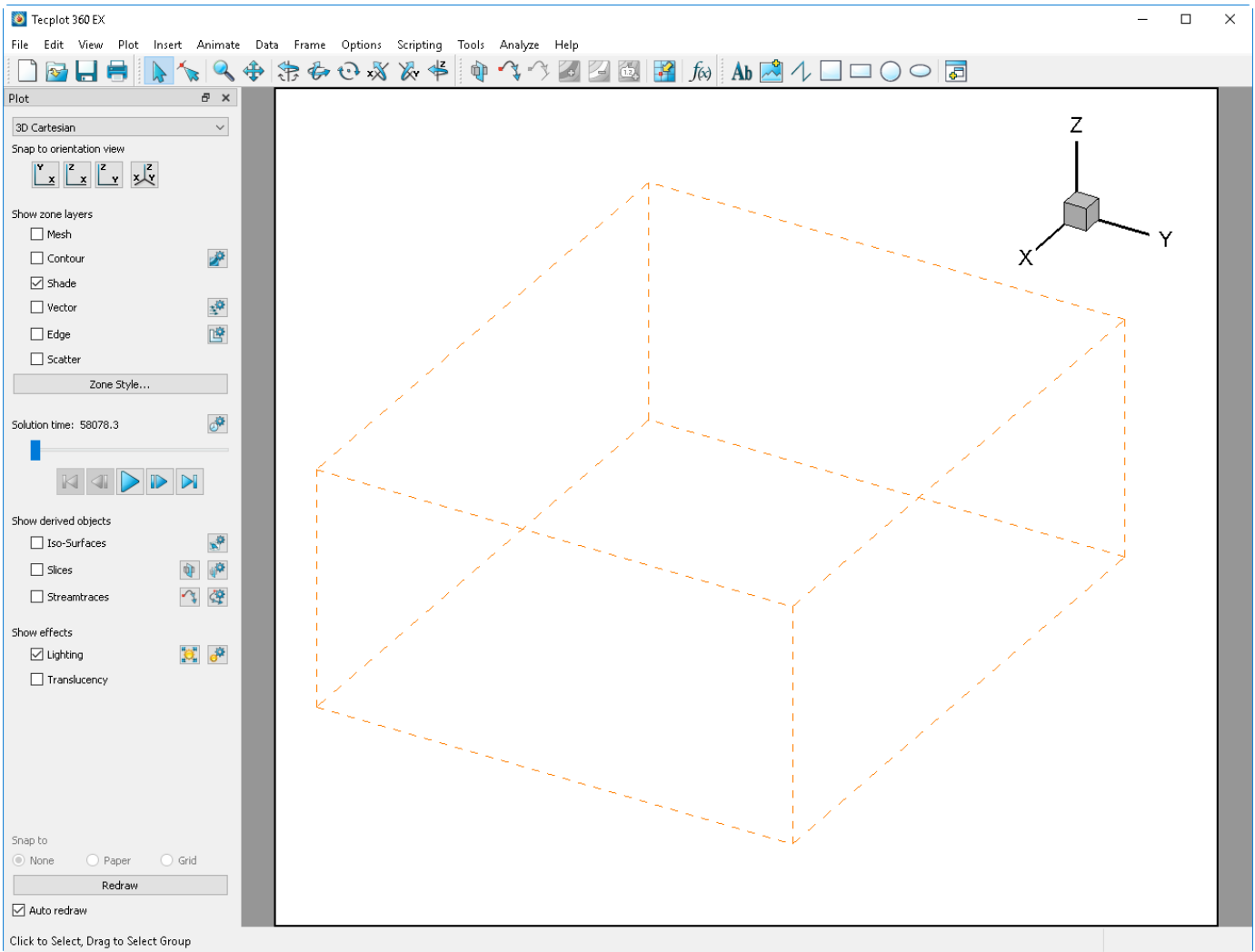

Step 2: Inspecting the Data

The orange bounding box represents a volume dataset that is loaded with no style. For more information on Surfaces to Plot see [Understanding Volume Surfaces](#). To see what data has been loaded, open the Data Set Info dialog. From the top of the screen select Data → Data Set Info. This will bring up a dialog with lists of loaded zones and variables.

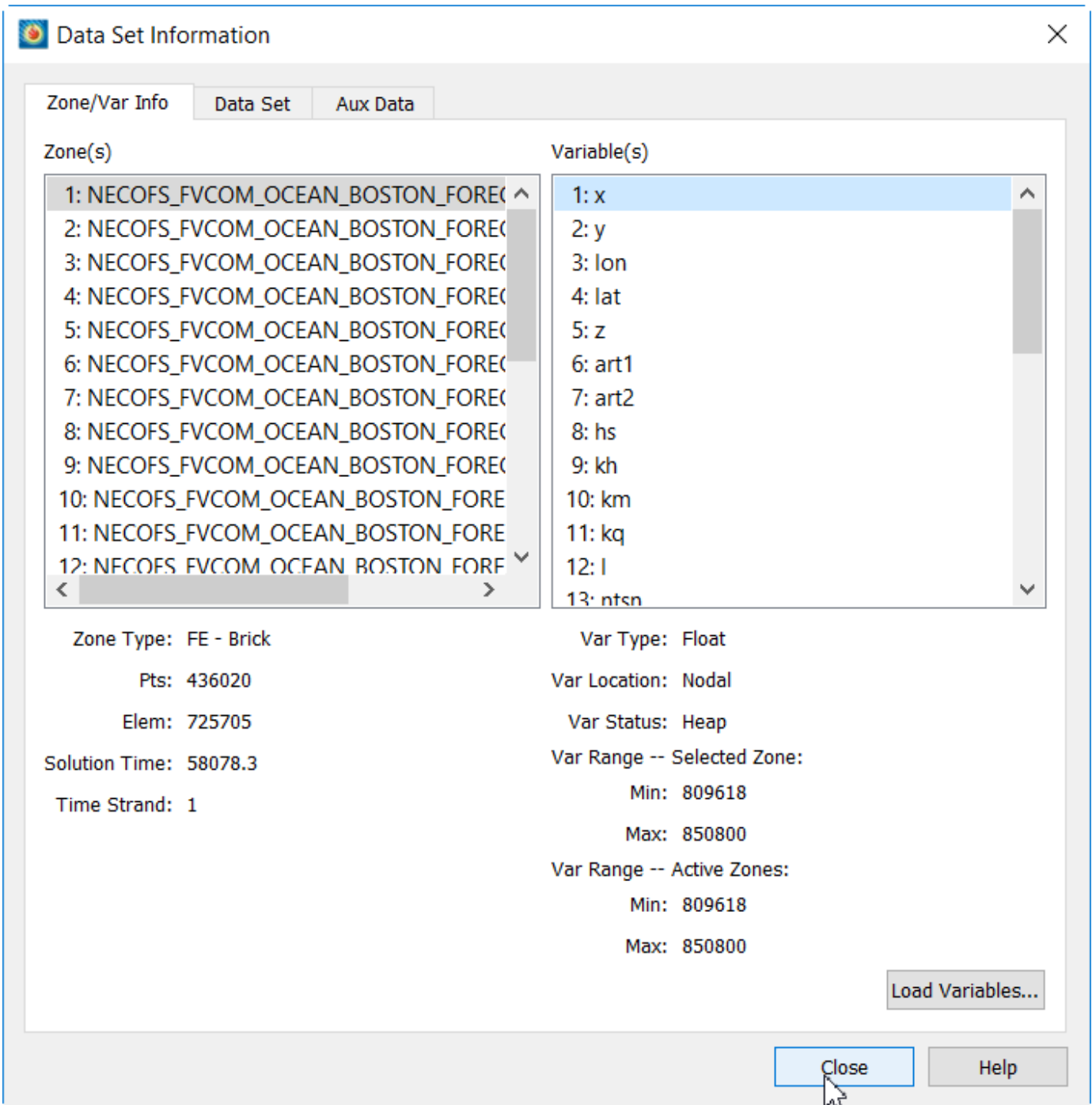

In the Zones field, we can see that the NetCDF ocean model has loaded 24 zones. In this case, each zone represents a new timestep of the data so we have 24 timesteps in total. We can also see in the other column the variables that have been loaded from the dataset. Close the Data Set Info dialog for now.

Making your first plot

Step 1: Turn on Contour to See the Domain

For the first representation of the data, turn on the Contour layer. Select the checkbox next to Contour on the Plot Sidebar.

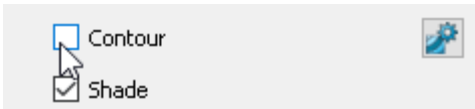

A pop-up will appear asking about Surfaces to Plot. For now, select "Yes". A contour plot will appear with the default contour variable selected. In this case it is "lon". This is because "lon" is the first, non-XYZ variable in the dataset.

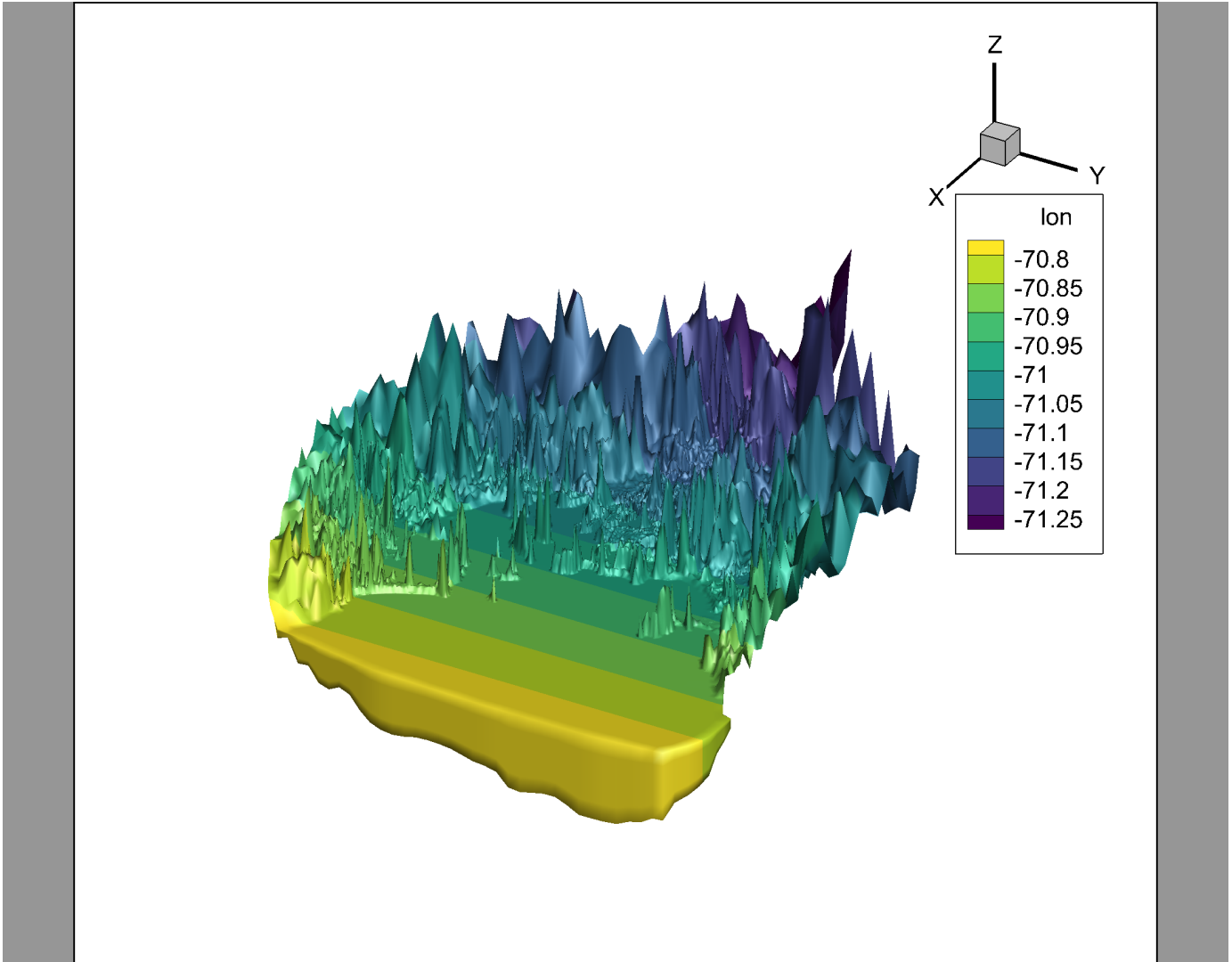

Step 2: Assign XYZ to Lon, Lat

For this plot, change the X and Y coordinates to Lon and Lat. This will make it easier for things like georeferenced images to be placed in the plot (see [Insert a Georeferenced Image](#)). To do this, select Plot → Assign XYZ and change the X variable to "lon" and the Y variable to "lat".

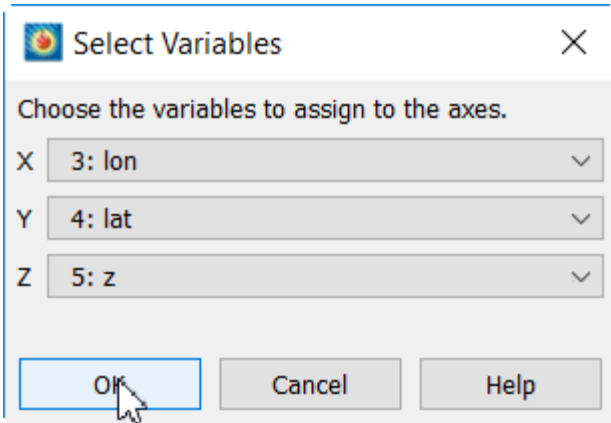

The plot will automatically update on pressing OK.

Step 3: Adjusting Z-scaling

You may have noticed pop-ups that say, "Aspect ratio exceeds ratio limit. The ratio has been adjusted." This is because Tecplot attempts to maintain a visually interesting axis ratio to prevent any one direction from being too small. However, adjust this ratio because the current plot is too tall in the Z direction. Select **Plot** → **Axis** to open the Axis Details dialog.

Towards the bottom of the dialog is the Dependency field. These options can determine XYZ dependency based on your information. The Z-axis needs to be smaller so set the plot "XY Dependent". Select the button next to "XY Dependent" and adjust the Z-axis size factor to be something like "0.000667".

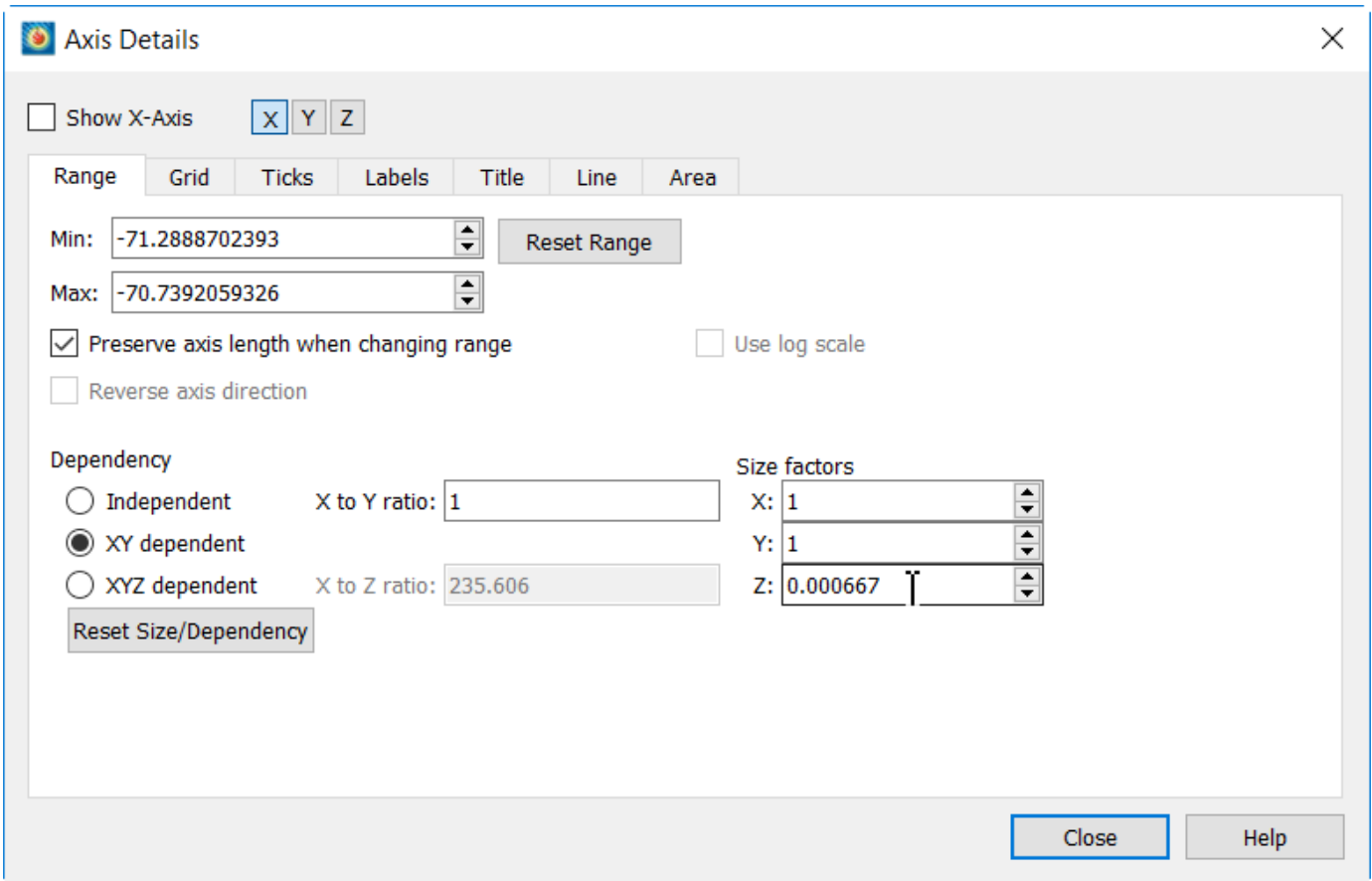

Note that the Z-axis is still exaggerated even at this ratio, but it gives a better understanding of the overall scale.

Step 4: Change View and Lighting

If you want the map to change to a top-down view, select the rollerball rotate (shown below), click, and drag the screen around to get a top-down perspective.

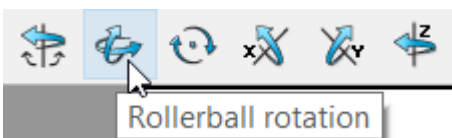

Another option is selecting "Snap to Orientation view" in the Plot Sidebar and selecting the XY perspective.

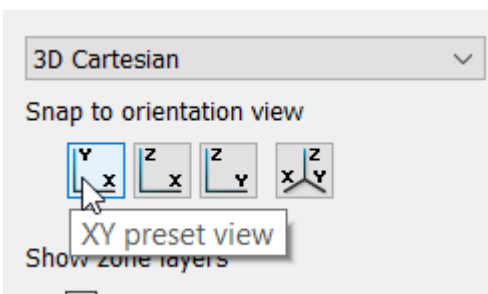

From this angle, lighting effects wash out the contour color. For now we can turn off lighting by

unchecking the "Lighting" checkbox on the Plot sidebar.

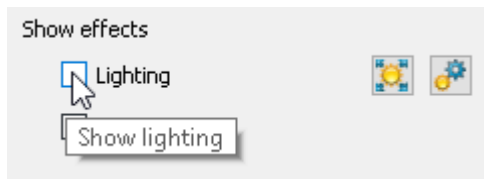

Now the plot should have no lighting effect and the contour data can be seen more clearly.

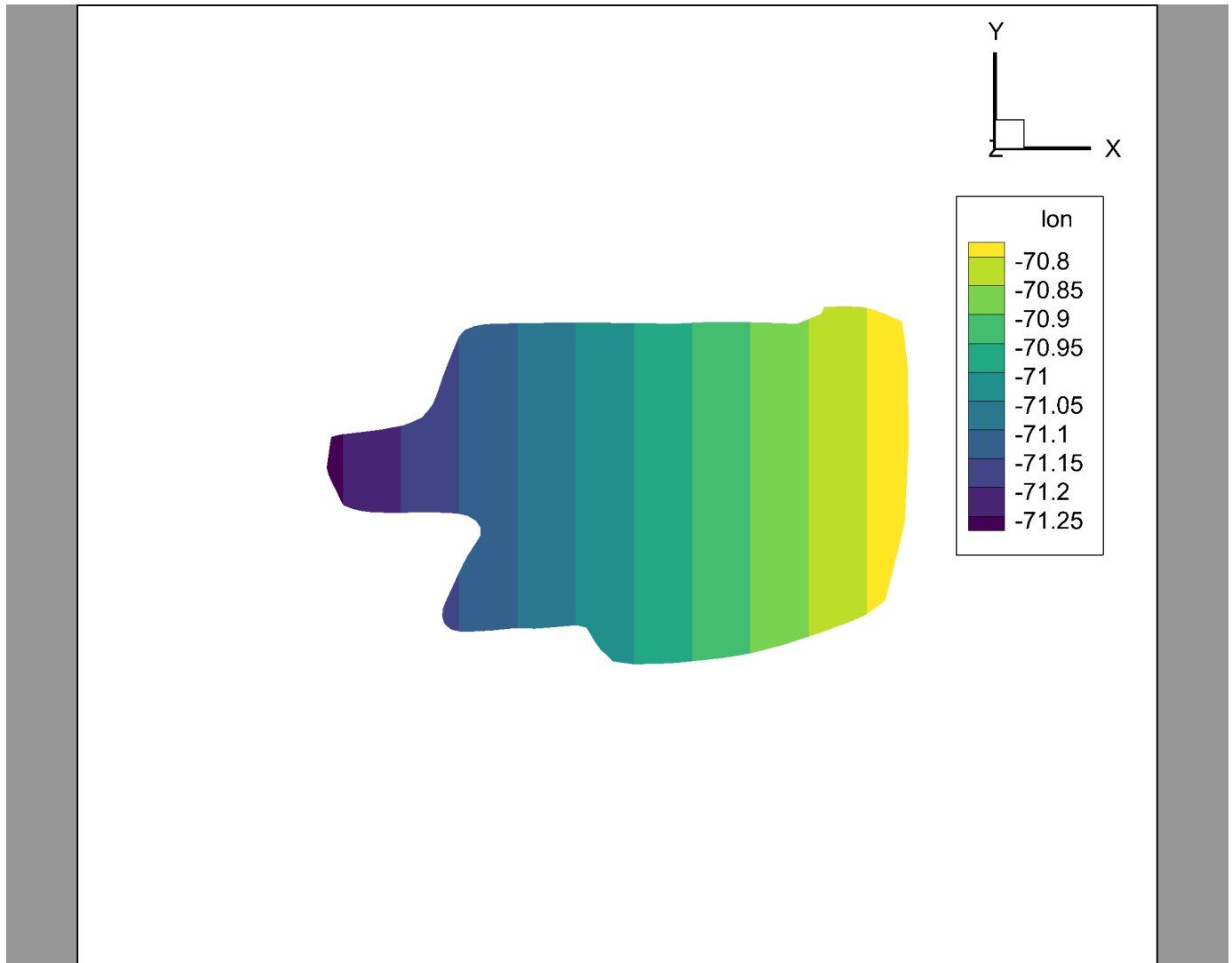

Step 5: Change the Contour Variable and Colormap

The contour variable has remained at the default of "lon" up until now, update to a more data relevant variable like "Salinity". To do this, select the button next to Contour on the Plot sidebar. The Contour & Multi-Coloring details menu appears.

Notice the dropdown list at the top of the dialog is set to "lon". Select the dropdown list and all the variables in your dataset appear. Now select "salinity" as your new contour variable. The plot will automatically update.

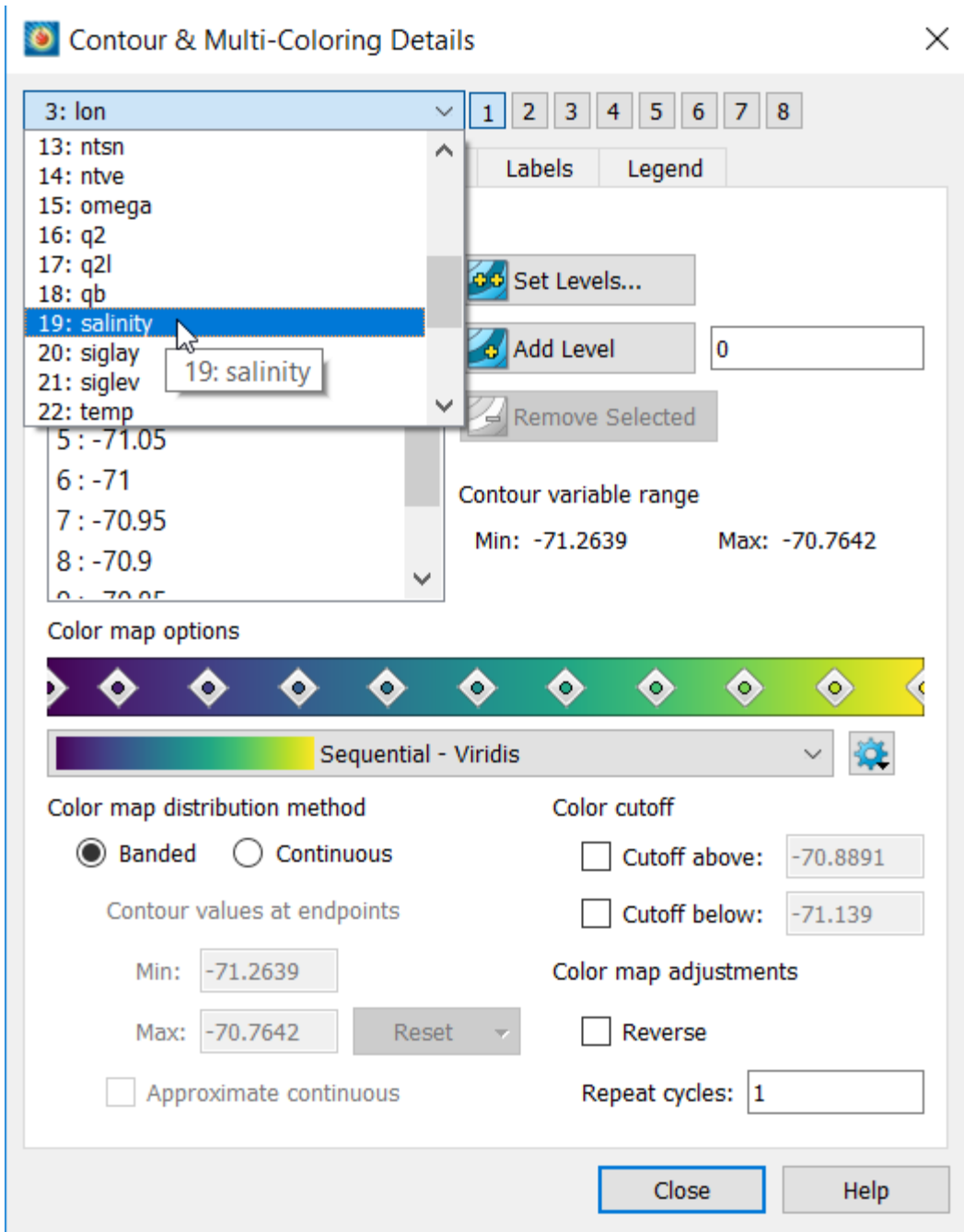

Also select a new colormap based on the cmocean colormaps, in this case, the "cmocean - haline" colormap which is designed to be used with salinity plots. To change the colormap select the colormap dropdown from the middle of the Contour & Multi-Coloring Details dialog, and select "cmocean - haline" option.

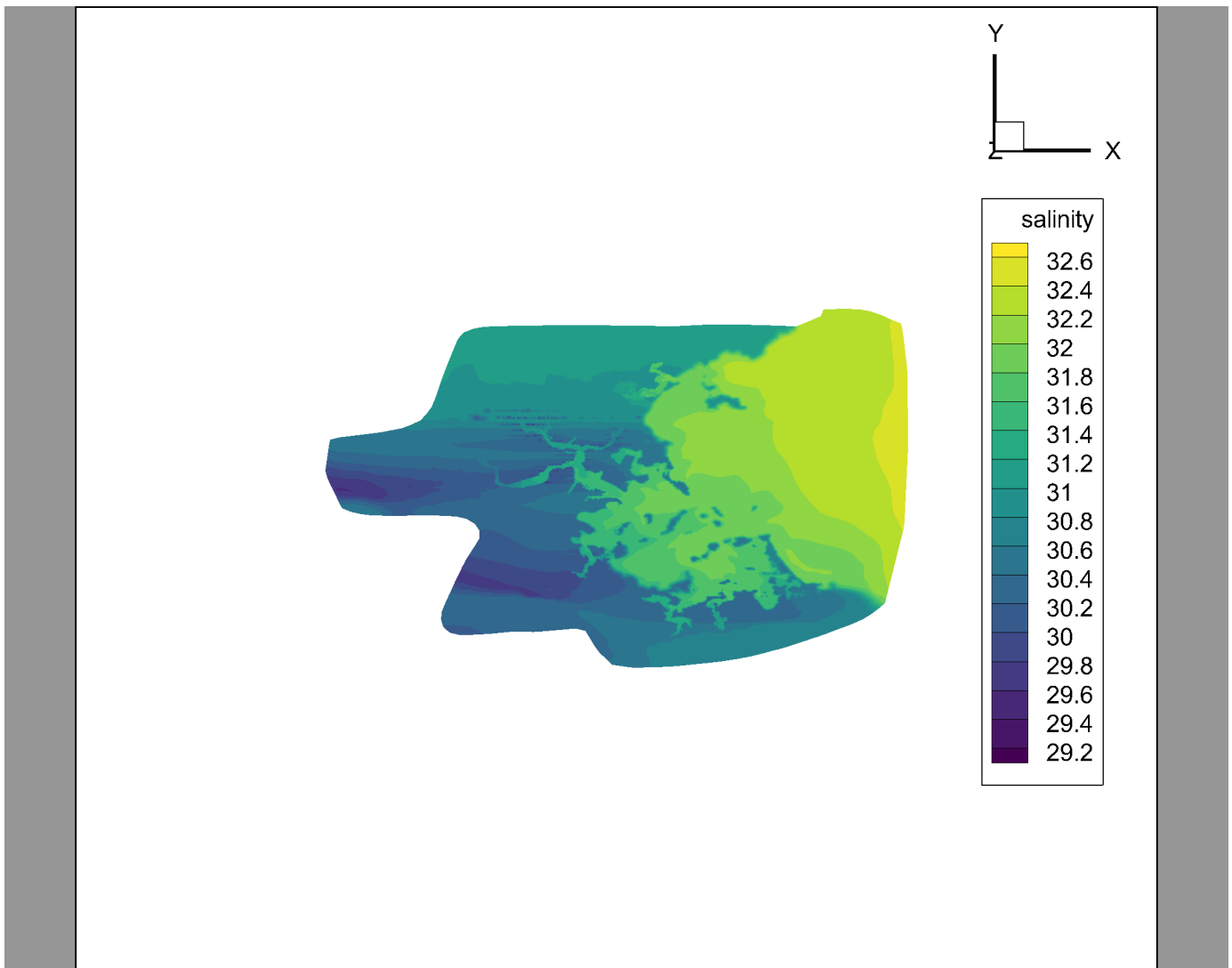

Step 6: Use Value Blanking to Hide Dry Land

After updating the plot to "salinity" notice the shoreline of Boston harbor within the plot. However, the contours extend out from beyond the shoreline. This dataset has a variable called "wet_nodes" to determine what is wet (denoted by the variable = 1) and what is dry (denoted by the variable = 0).

To hide the dry nodes on the plot where "wet_nodes" is equal to 0. Go to Plot→Blanking→Value Blanking to pull up the Value Blanking dialog.

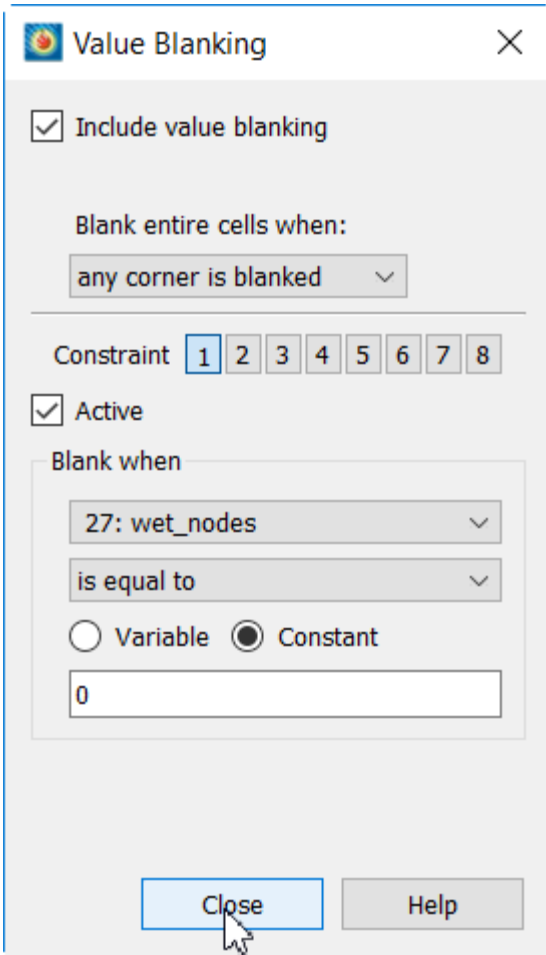

Then turn on the "Include value blanking" checkbox. This will tell the plot that we want to blank something. Change the Blank when fields to be when "wet_nodes", "is equal to", "Constant" and "0". Then select the "Active" checkbox. The plot will update accordingly. The exact value blanking options are in the image above and final plot should look like this:

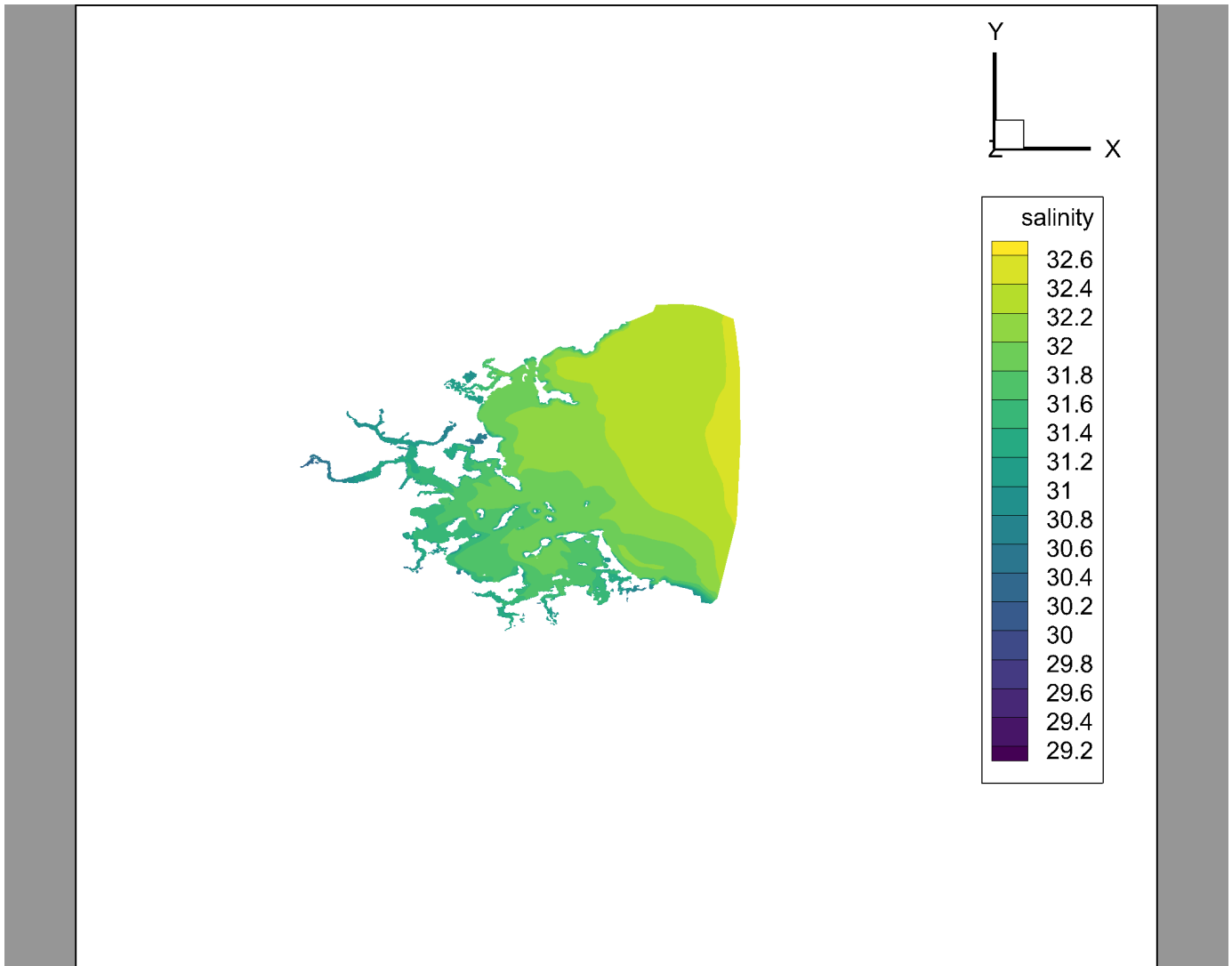

Step 7: Animating and Exporting a Movie File

Now that the plot is looking good, let's animate through time. Select the Play button on the Plot sidebar to play the animation. The plot will show the ebbing and flowing of salinity in the Boston harbor.

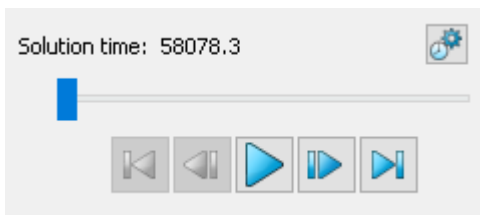

Note that the first animation takes longer because it needs to load data. The second play through will be faster as the data has already been loaded.

Now we want to save this animation to a movie file. On the Plot sidebar select the button next to Solution time and the Time Animation details dialog will appear. This dialog can give more control over your plot animation but since the default settings are already sufficient, select the "Export to File" button next to the VCR buttons on the Time Animation details dialog.

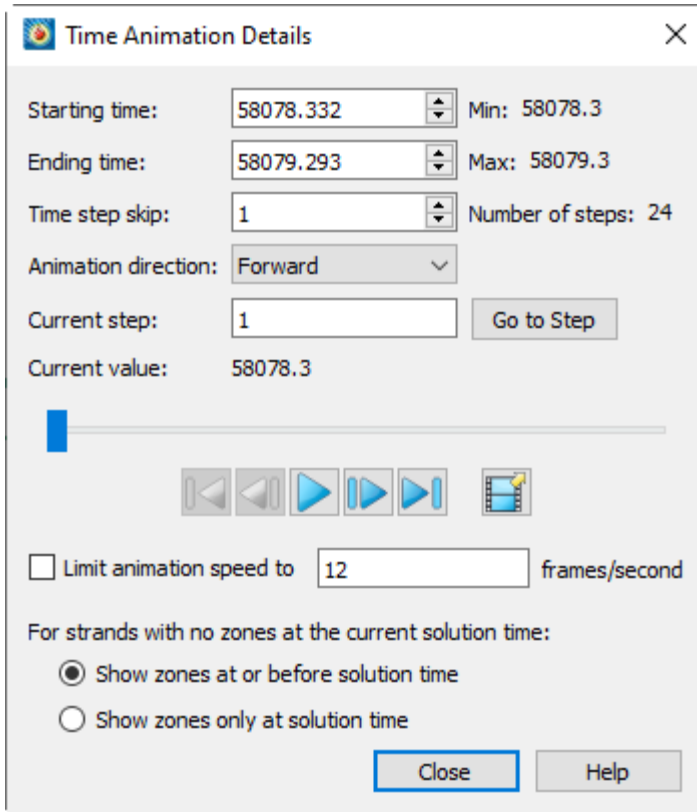

From the Export dialog, we can select things such as export format, image width, antialiasing, and animation speed. For this instruction, select the MPEG-4 format. This will create a file with an .mp4 extension that is usable by most video viewers. Also, turn on antialiasing as well to get the definition on the shoreline and have smoother lines. Keep everything else the default and click OK.

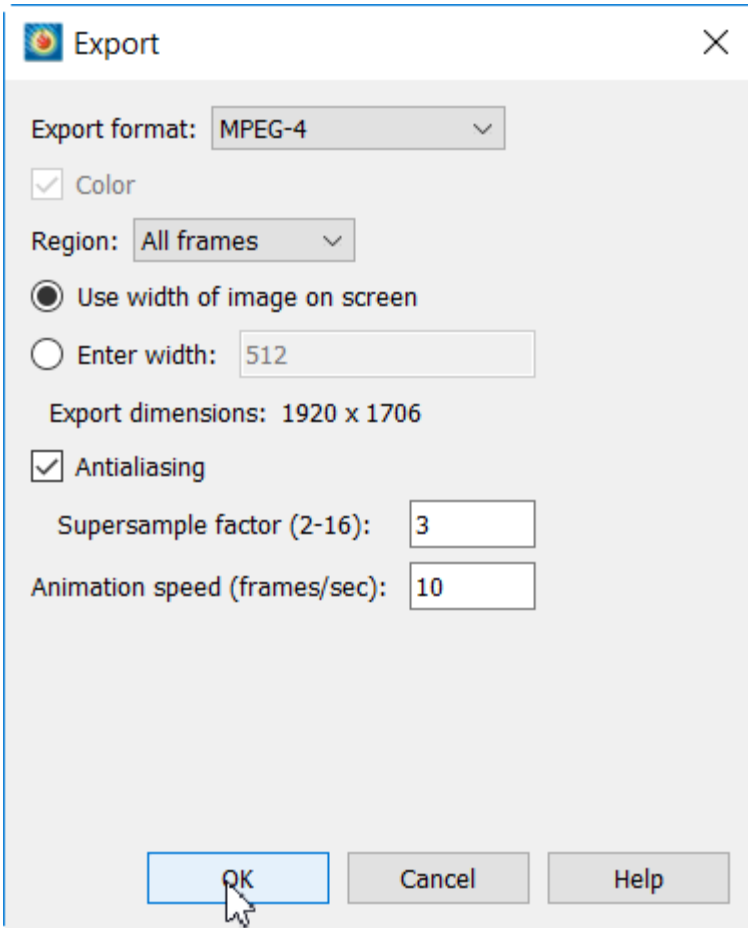

Next, save the file to a convenient location as "boston_salinity.mp4". Congratulations you've created your first Tecplot ocean animation!

Specific Ocean Plots

The next few sections focus on specific quick plots that can be achieved with this dataset. The goal being to teach how to create interesting plots quickly.

Visualizing Surface Velocities

This section is a continuation from the previous section. If you are joining partway through, open the [Ocean1.lay](#) from the [finallayouts](#) directory.

Step 1: Turn on the Vectors

First turn on the Vector layer from the Plot Sidebar to visualize surface velocities. Select the checkbox next to Vector much like how we turned on the contour layer (see [Step 1: Turn on Contour to See the Domain](#)). The Select Variables menu should appear allowing the selection of the U, V, and W variables.

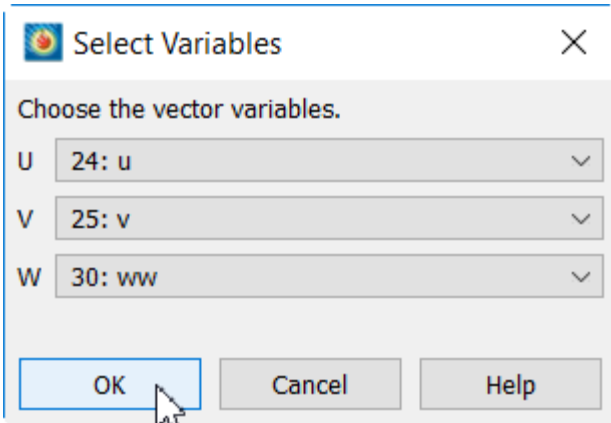

For the next section, select the u, v, and "ww" variables from the dropdown.

Step 2: Value Blank Siglev

At this point all surfaces are showing vectors including the sea floor. To only show the sea surface, use value blanking to isolate the ocean surface by blanking when "siglev" is less than 0. Using the second value blanking constraint, select Plot → Blanking → Value Blanking and update the options to match the image below. Be sure to change the "Blank entire cells when" option to "all corners are blanked".

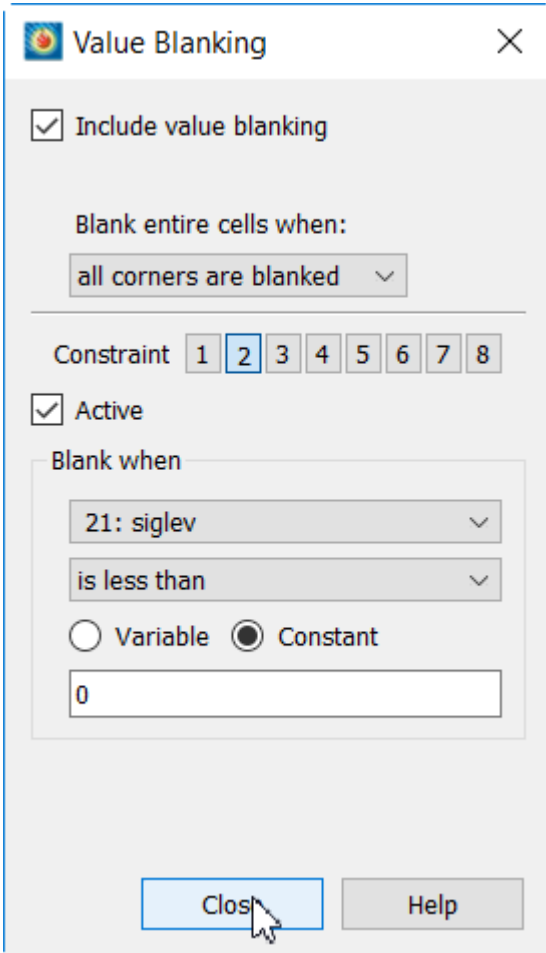

Step 3: Use Vector Tangents

Because the view is still 3D model, some vectors will look like dots as the vector is pointing vertically toward the screen. To prevent this turn on the Vector Tangents from the Zone Style dialog. Select the Zone Style button from the Plot Sidebar and the Zone Style dialog will appear.

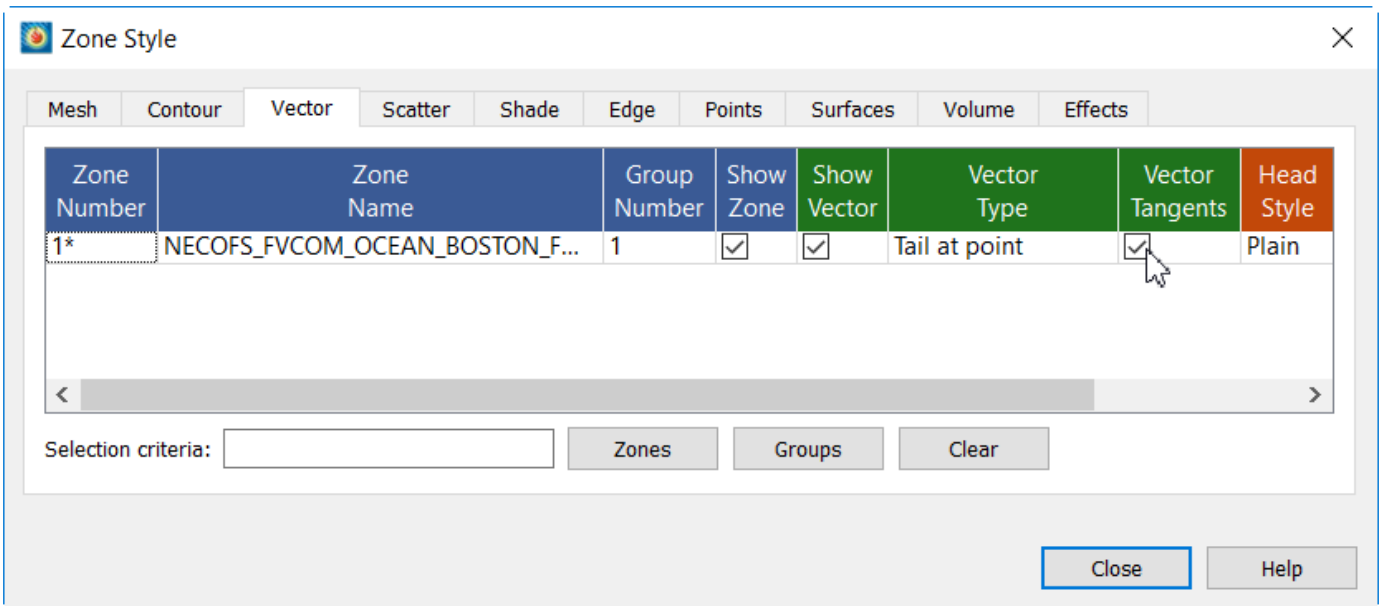

Select the Vector tab and then select the checkbox under "Vector Tangents". This will ensure that the vectors will be displayed tangential to the surface. Close the Zone Style dialog.

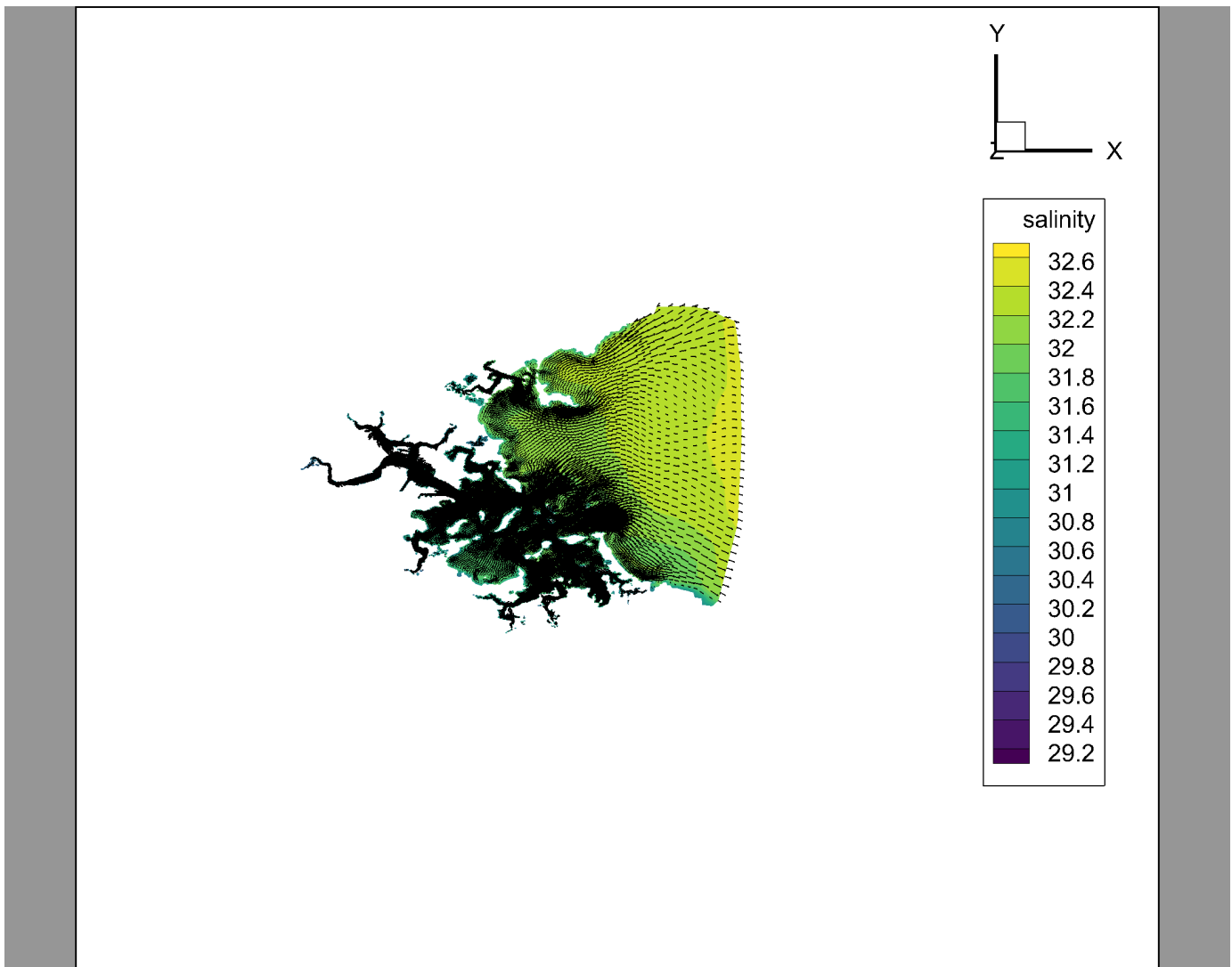

Step 4: Calculate Velocity Magnitude

Since the Velocity Magnitude isn't located in the current dataset, we will need to calculate it. Typically new equations can be calculated using the Data Alter menu (Data → Alter → Specify Equations). However, the CFD Analyze menu can also be used to calculate Velocity magnitude which will prevent the need to type the equations in manually.

Firstly, we will need to set up the CFD Analyze menu by letting the Analyzer know the data's field variables. Select Analyze → Field Variables to bring up the Field Variables dialog. From this dialog we can set the necessary variables for analysis. For this calculation, setting the convective variables is sufficient. Be sure the Velocity button is checked and the vectors variables are the same as what is shown on the plot (u, v, and ww).

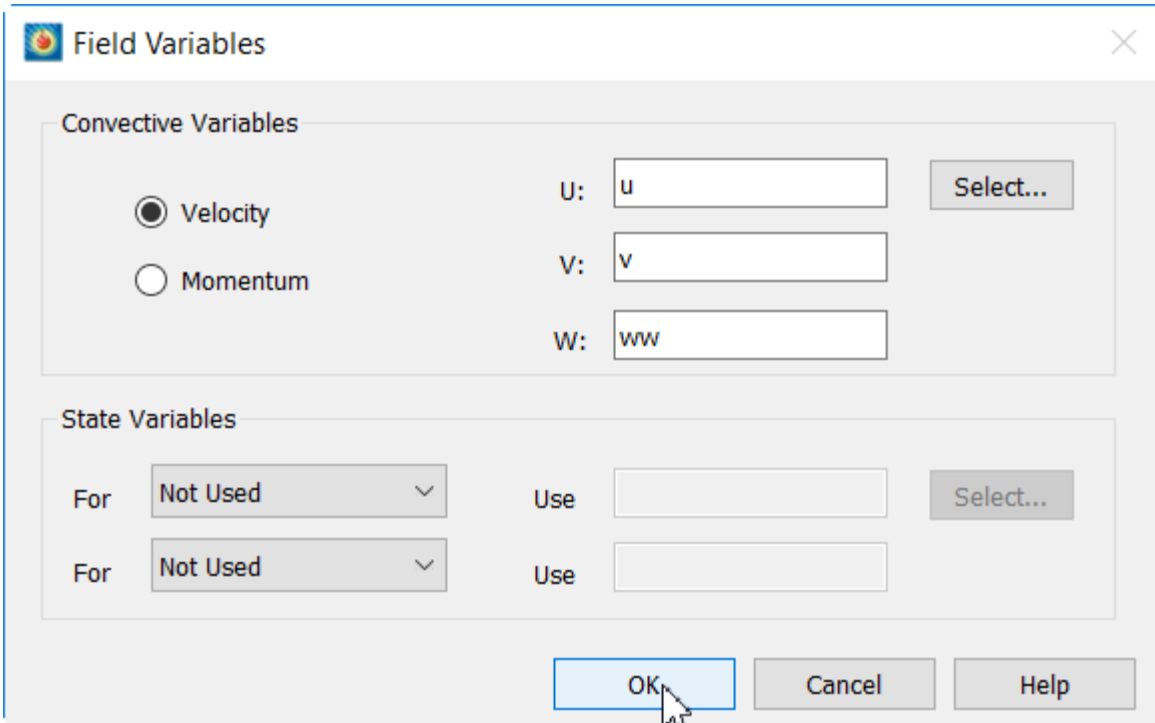

Next select Analyze → Calculate Variables. This will bring up the Calculate Variables page. Select Velocity magnitude as the variable calculation and uncheck the Calculate on Demand button. This will make sure the points are calculated now instead of when the variable is plotted.

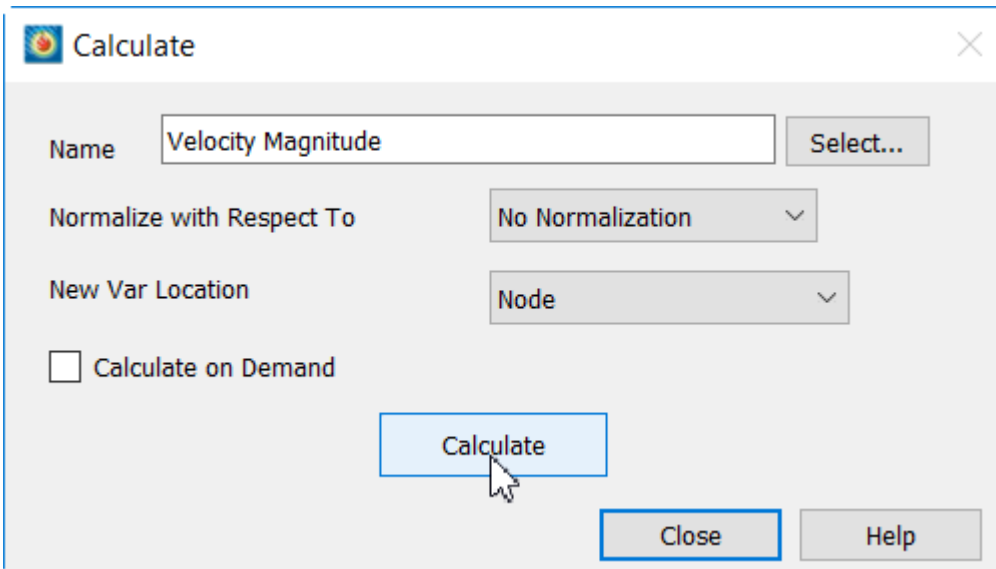

Then select Calculate and the Velocity Magnitude variable will begin the calculation process for all zones. Information will appear upon completion that the calculation was successful. Now in the Data Set Info dialog (Data → Data Set Info) you can see the Velocity Magnitude variable at the end of the variable list.

Zone/Var Info Data Set Aux Data

Zone(s)

- 1: NECOFS_FVCOM_OCEAN_BOSTON_FORECAST
- 2: NECOFS_FVCOM_OCEAN_BOSTON_FORECAST
- 3: NECOFS_FVCOM_OCEAN_BOSTON_FORECAST
- 4: NECOFS_FVCOM_OCEAN_BOSTON_FORECAST
- 5: NECOFS_FVCOM_OCEAN_BOSTON_FORECAST
- 6: NECOFS_FVCOM_OCEAN_BOSTON_FORECAST
- 7: NECOFS_FVCOM_OCEAN_BOSTON_FORECAST
- 8: NECOFS_FVCOM_OCEAN_BOSTON_FORECAST
- 9: NECOFS_FVCOM_OCEAN_BOSTON_FORECAST
- 10: NECOFS_FVCOM_OCEAN_BOSTON_FORECAST
- 11: NECOFS_FVCOM_OCEAN_BOSTON_FORECAST
- 12: NECOFS_FVCOM_OCEAN_BOSTON_FORECAST
- 13: NECOFS_FVCOM_OCEAN_BOSTON_FORECAST
- 14: NECOFS_FVCOM_OCEAN_BOSTON_FORECAST
- 15: NECOFS_FVCOM_OCEAN_BOSTON_FORECAST
- 16: NECOFS_FVCOM_OCEAN_BOSTON_FORECAST
- 17: NECOFS_FVCOM_OCEAN_BOSTON_FORECAST
- 18: NECOFS_FVCOM_OCEAN_BOSTON_FORECAST
- 19: NECOFS_FVCOM_OCEAN_BOSTON_FORECAST
- 20: NECOFS_FVCOM_OCEAN_BOSTON_FORECAST
- 21: NECOFS_FVCOM_OCEAN_BOSTON_FORECAST
- 22: NECOFS_FVCOM_OCEAN_BOSTON_FORECAST
- 23: NECOFS_FVCOM_OCEAN_BOSTON_FORECAST

Variable(s)

- 8: hs
- 9: kh
- 10: km
- 11: kq
- 12: l
- 13: ntsn
- 14: ntve
- 15: omega
- 16: q2
- 17: q2l
- 18: qb
- 19: salinity
- 20: siglay
- 21: siglev
- 22: temp
- 23: tpeak
- 24: u
- 25: v
- 26: wdir
- 27: wet_nodes
- 28: wet_nodes_prev_int
- 29: wlen
- 30: ww
- 31: Velocity Magnitude

Zone Type: FE - Brick

Pts: 436020

Elem: 725705

Solution Time: 58078.3

Time Strand: 1

Var Type: Float

Var Location: Nodal

Var Status: Heap

Var Range -- Selected Zone:

Min: 0

Max: 1.17643

Var Range -- Active Zones:

Min: 0

Max: 1.17643

Load Variables...

Close

Help

Step 5: Contour by Velocity Magnitude

To contour by velocity magnitude, see the previous section [Step 5: Change the Contour Variable and Colormap](#) to update the Contour variable. Then switch the colormap to "cmocean-speed", designed to be used with velocity. We also want to change the contour levels to only include data relevant to our study.

To do this, select Set Levels from the Contour & Multi-Coloring details dialog. When the dialog appears, change the option of Range Distribution to Min, Max, and Delta. With the minimum level at 0 and maximum level at 0.6 with a delta of 0.1.

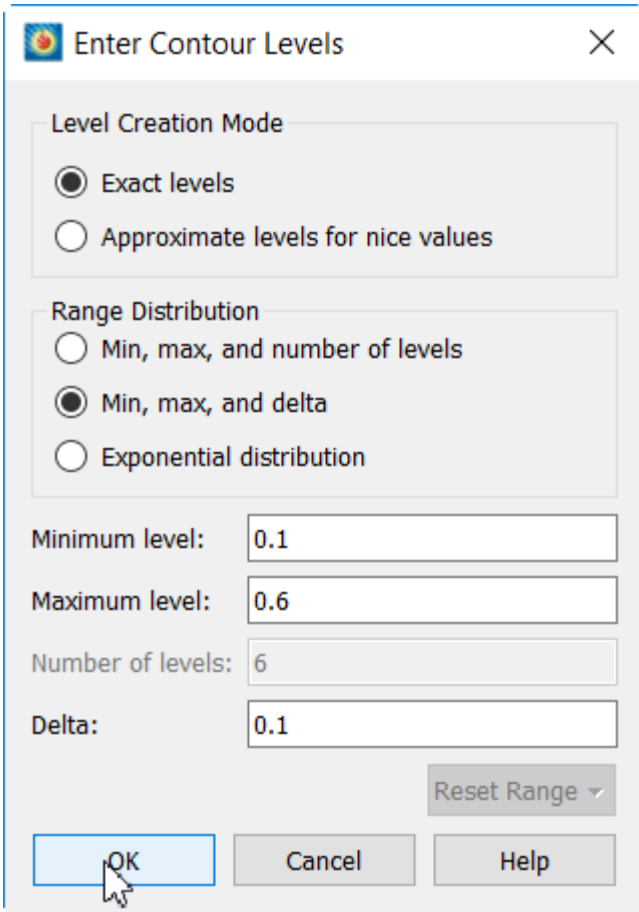

Click OK and close the Contour & Multi-Coloring Details dialog. Here is what your plot should look like currently.

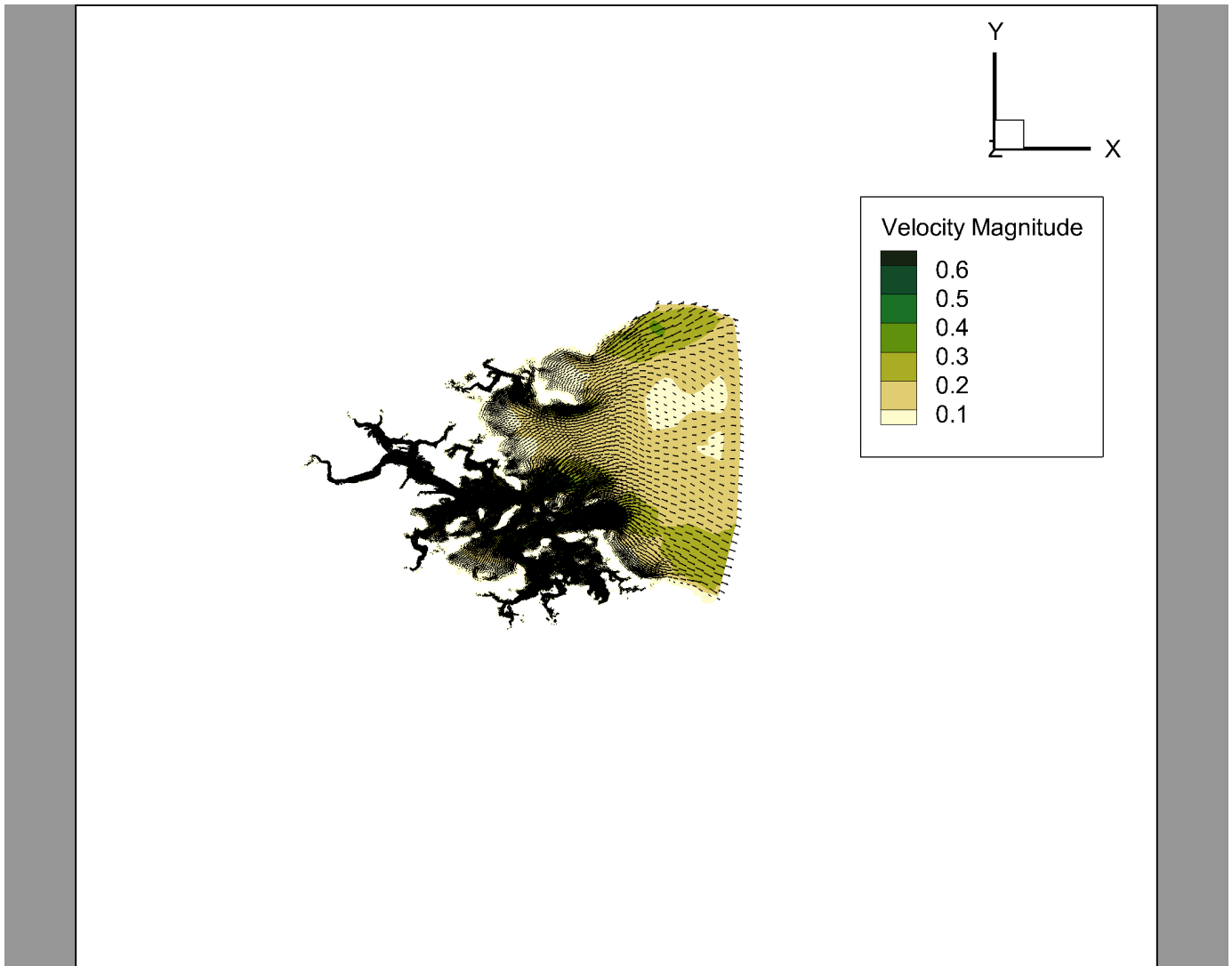

Step 6: Resize Vectors

Since the vectors on screen are a little bit too large in the more dense areas of the plot, we should change the length. Select Plot → Vector → Details to adjust the vector length from the Vector Details dialog.

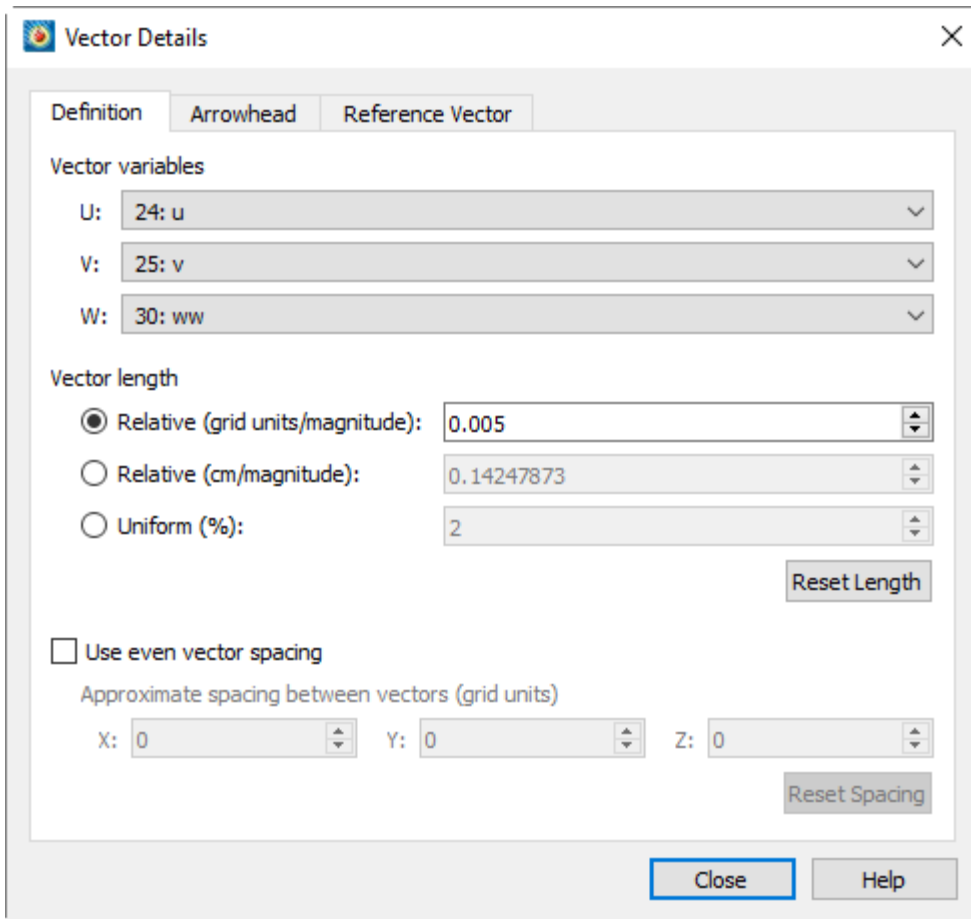

Set the Length to Relative (grid units/magnitude) and set the number to 0.005. This will update the vectors to be smaller and more manageable in the dense areas of the plot. Your final plot should be similar to the one you see below:

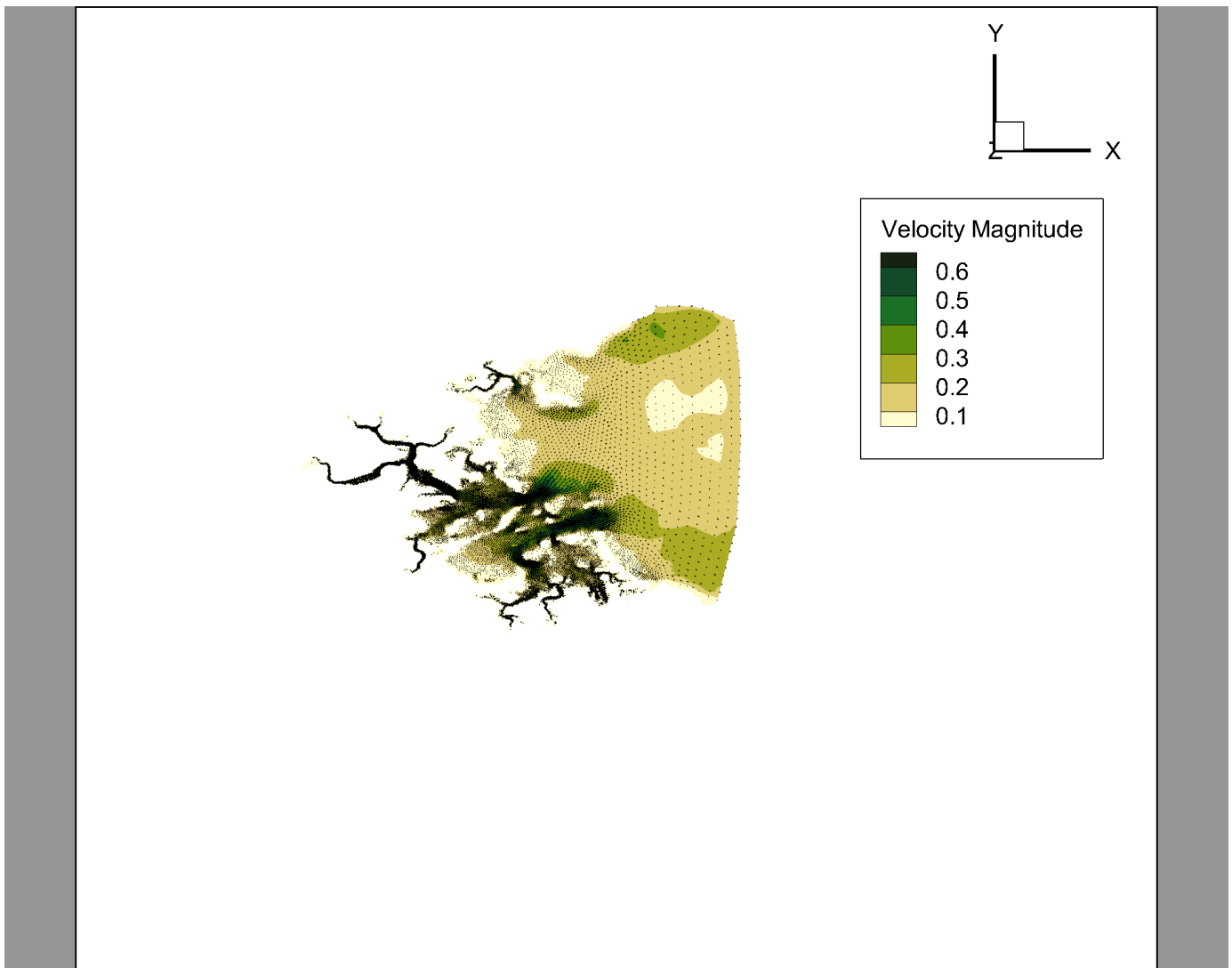

At this point, use the zoom and pan tools to explore different regions of the data.

Insert a Georeferenced Image

Step 1: Set Up Coordinate System

Before inserting the image, ensure the coordinate system on your plot is the same as the georeferenced image that you are trying to insert. If a georeferenced image is inserted with a different coordinate system than the dataset, the image will not appear in the correct location. For this example, set the Boston dataset to be in lon/lat coordinates.

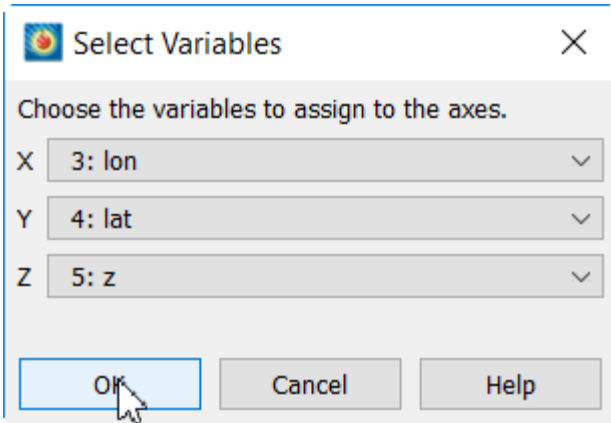

Select Plot > Assign XYZ and assign lon to the X variable and assign lat to the Y variable. If you are continuing from the previous exercises, this step will already be done.

Step 2: Insert Georeferenced Image

Select Insert > Image/Georeferenced Image and select the 'boston.png' file from the same folder the data was loaded. The map of the Boston harbor will appear alongside the dataset. Click the Play button and notice that the colormap disappears behind the image as we animate through time.

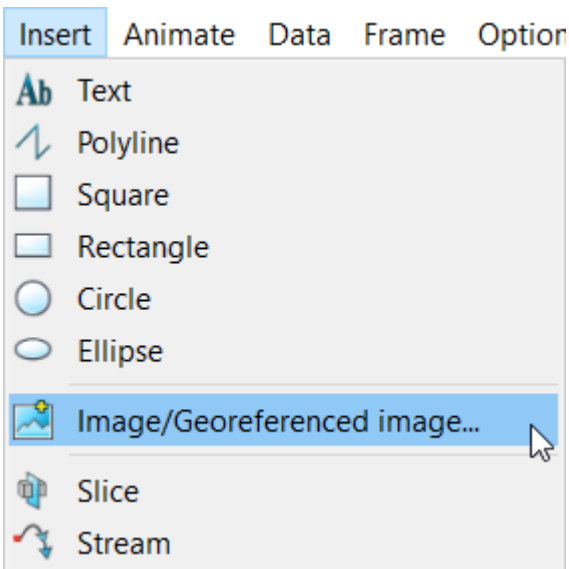

Step 3: Update Image location

Because the sea surface height changes over time, the contour plots disappear behind the georeferenced image. Since we want the contours to always be on top, we will update the height of the georeferenced image. Right click the georeferenced image and select Image Details. The 3D Image Geometry Details dialog appears. Notice that the Z position field defaults to 0. Update this field to -10 and click Accept.

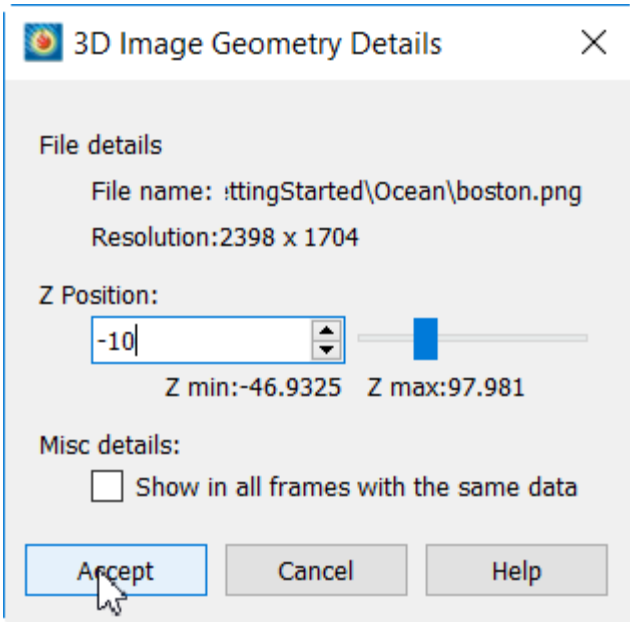

The image will now be moved below the contour flooding. Select the play button again from the Plot Sidebar and notice how the sea height fluctuates but never falls below the image like before.

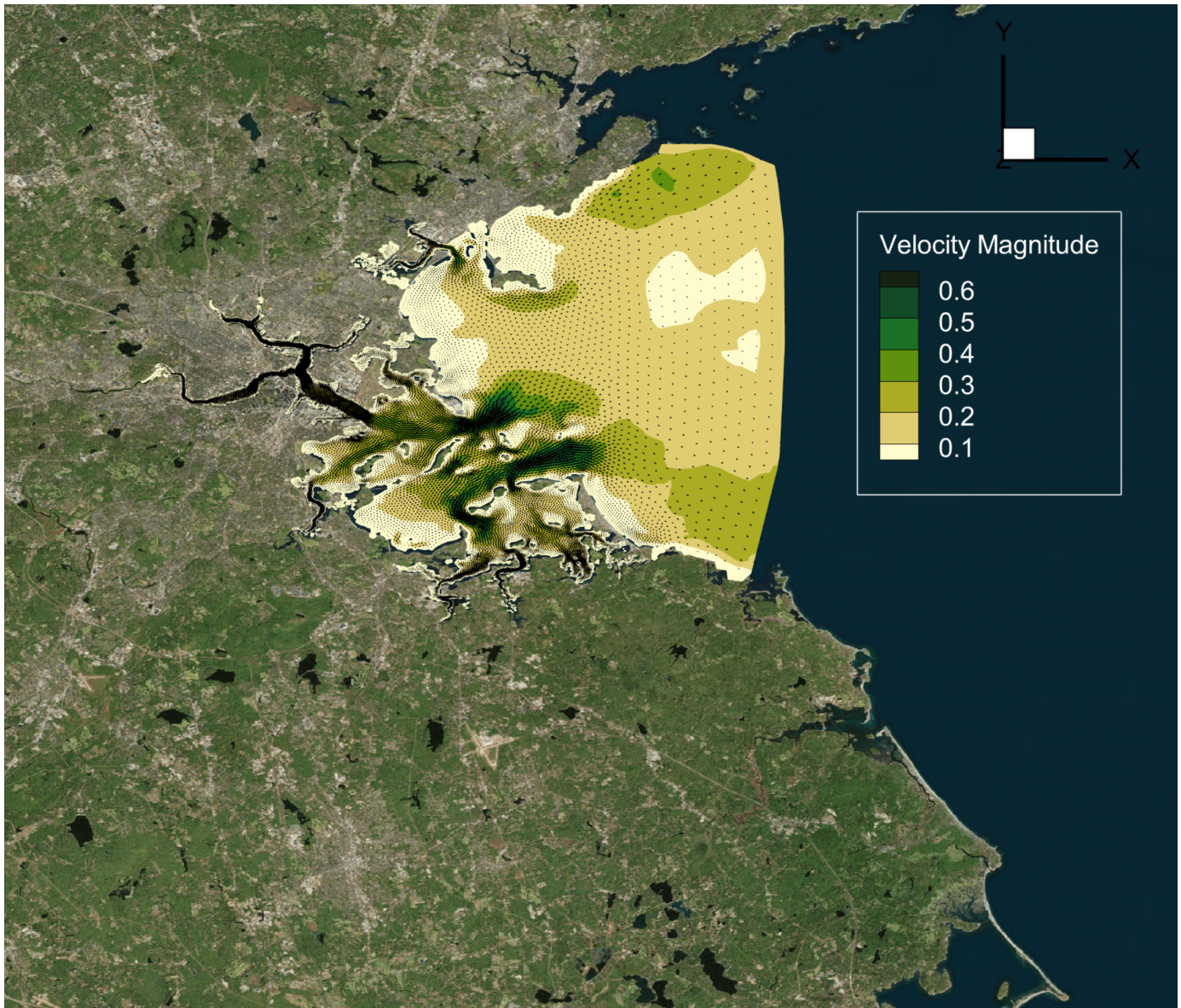

Understanding Salinity Stratification

The next portion will use an iso-surface to identify the bathymetry of the dataset and use slices to identify layers through the volume. If you are continuing from the previous portion, remove the georeferenced image and turn off the blanking of siglev.

Step 1: Turn off Zone Layers

On the plot sidebar, turn off all of the zone layers. This will revert the plot to an empty workspace with an orange bounding box much like when we first loaded the data.

Step 2: Show the Bathymetry

Turn on the iso-surface checkbox on the plot sidebar. This will create a surface based on a contour variable value. In this case, we want to create an iso-surface to show the bathymetry. To do this, select the button next to the iso-surface checkbox. This will bring up the Iso-surface Details dialog.

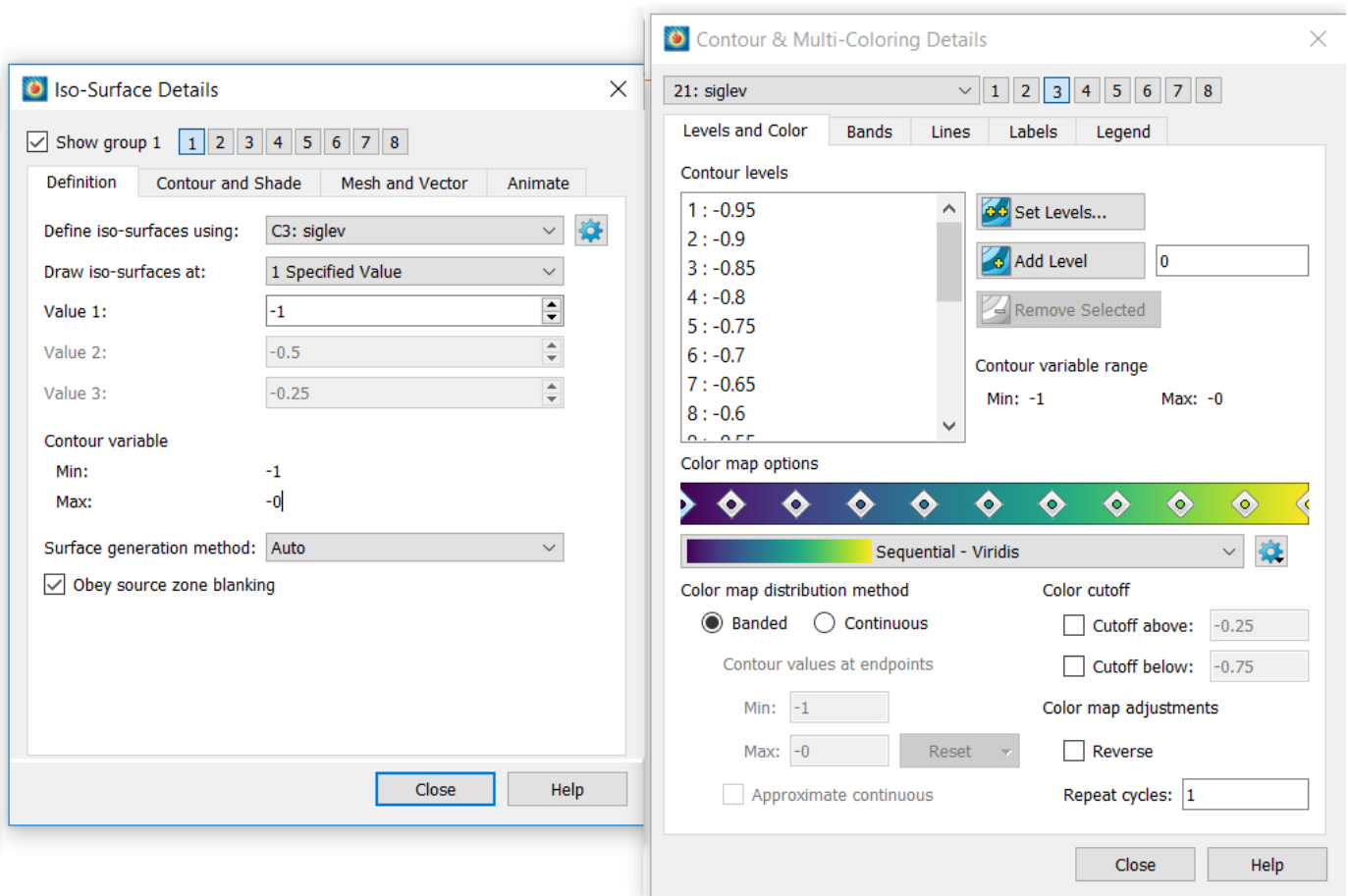

Set the Iso-surface definition to C3 and enter the value of -1. Update the Contour variable in group three to `siglev` via the Contour Details dialog. See the above image for the Contour details and Iso-surface details options. Also while you have the Contour details dialog open, update the contour group two to be colored by z using the "cmocean-deep" colormap and with the colormap reversed. Then select C2 in the Contour tab of the Iso-surface details dialog. See the below image for the correct options for how to update the iso-surface contour.

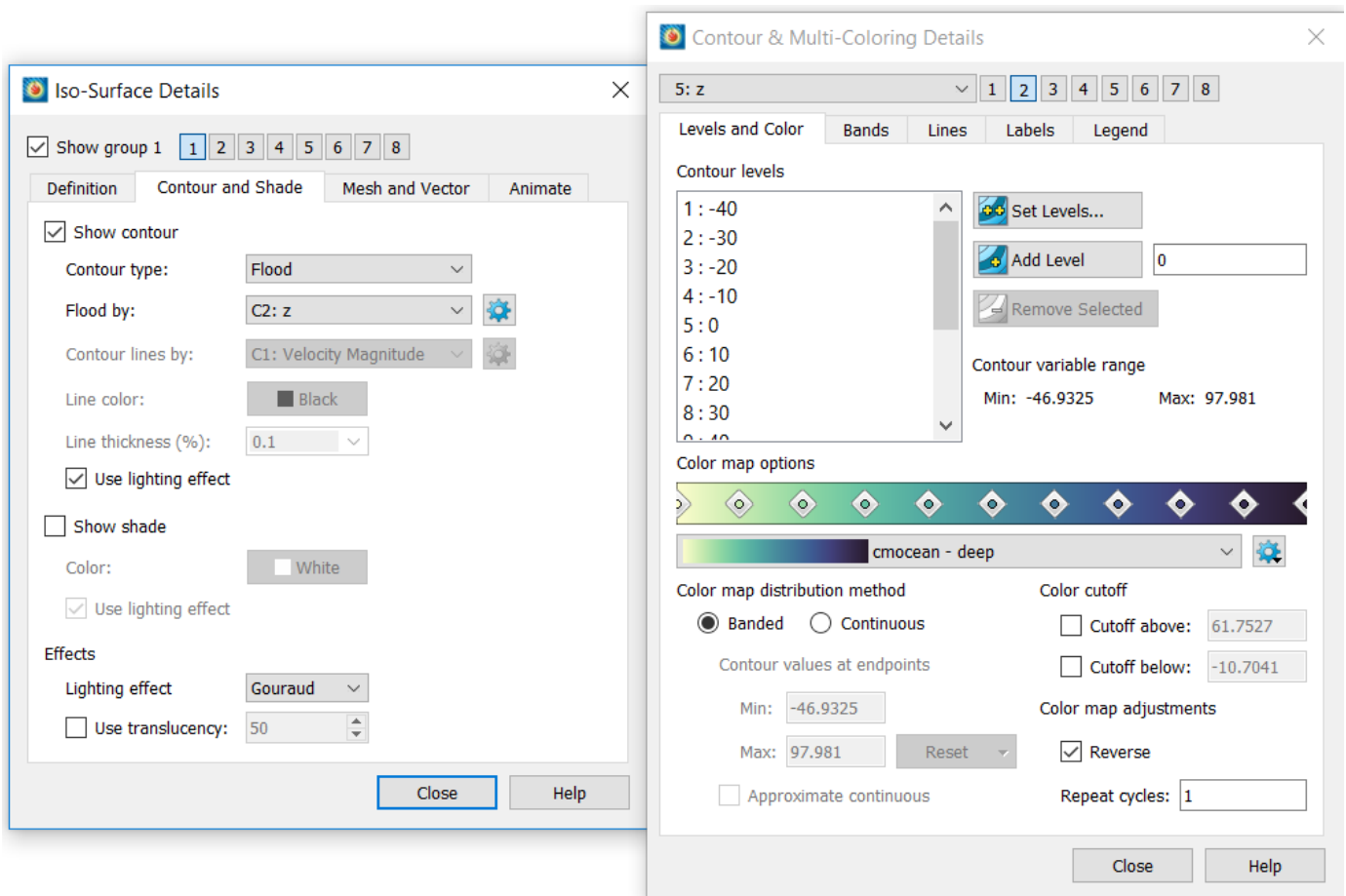

Setting the iso-surface definition will create an iso-surface of the bottom layer of the dataset. Rotating the plot around, you can see the ridges of the harbor floor through the dataset.

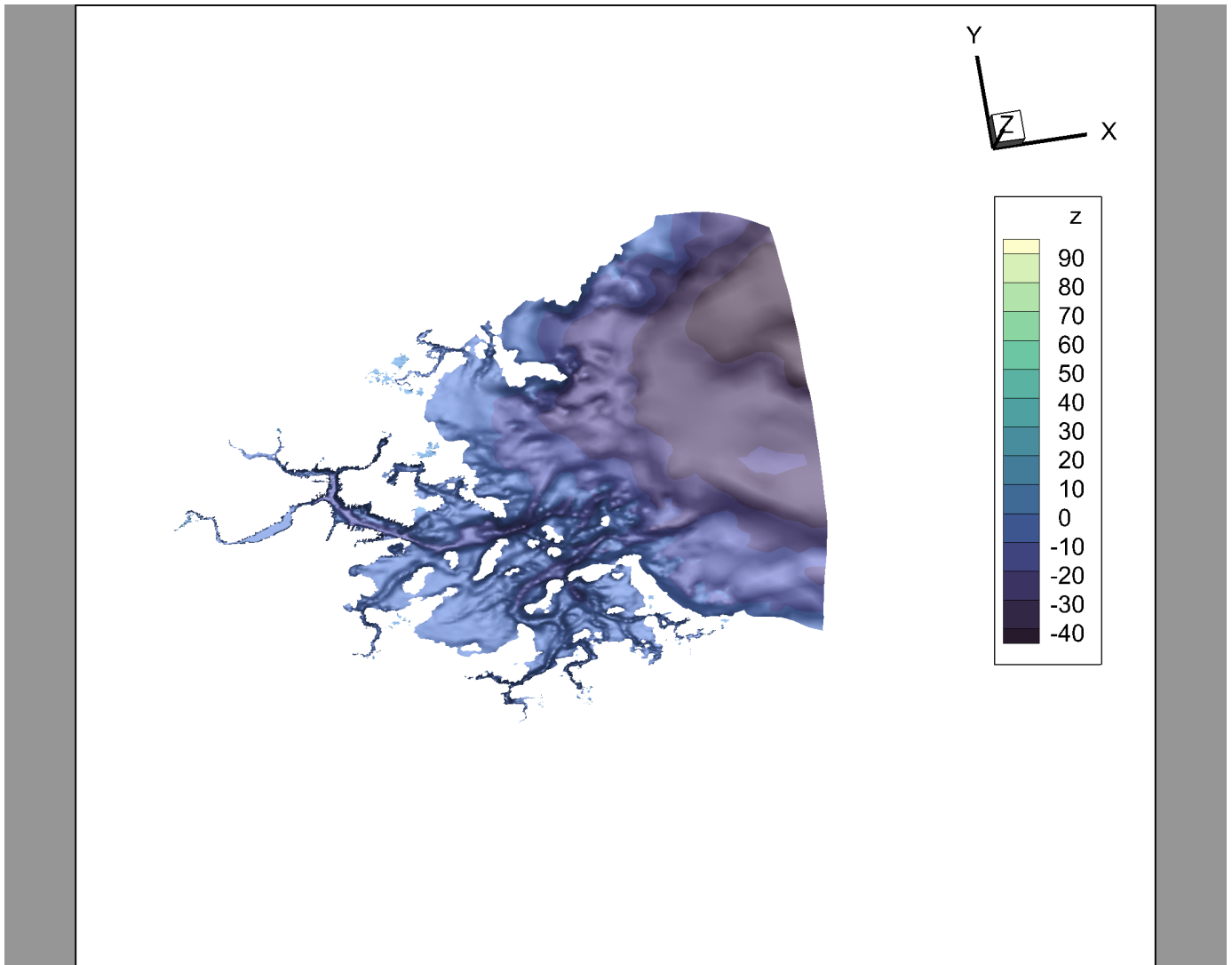

Step 3: Place a Slice

Next, place a slice using the Slice tool and the Slice Details dialog using Y-planes at a position of 42.33. This will place a slice right around the middle half of the Boston dataset.

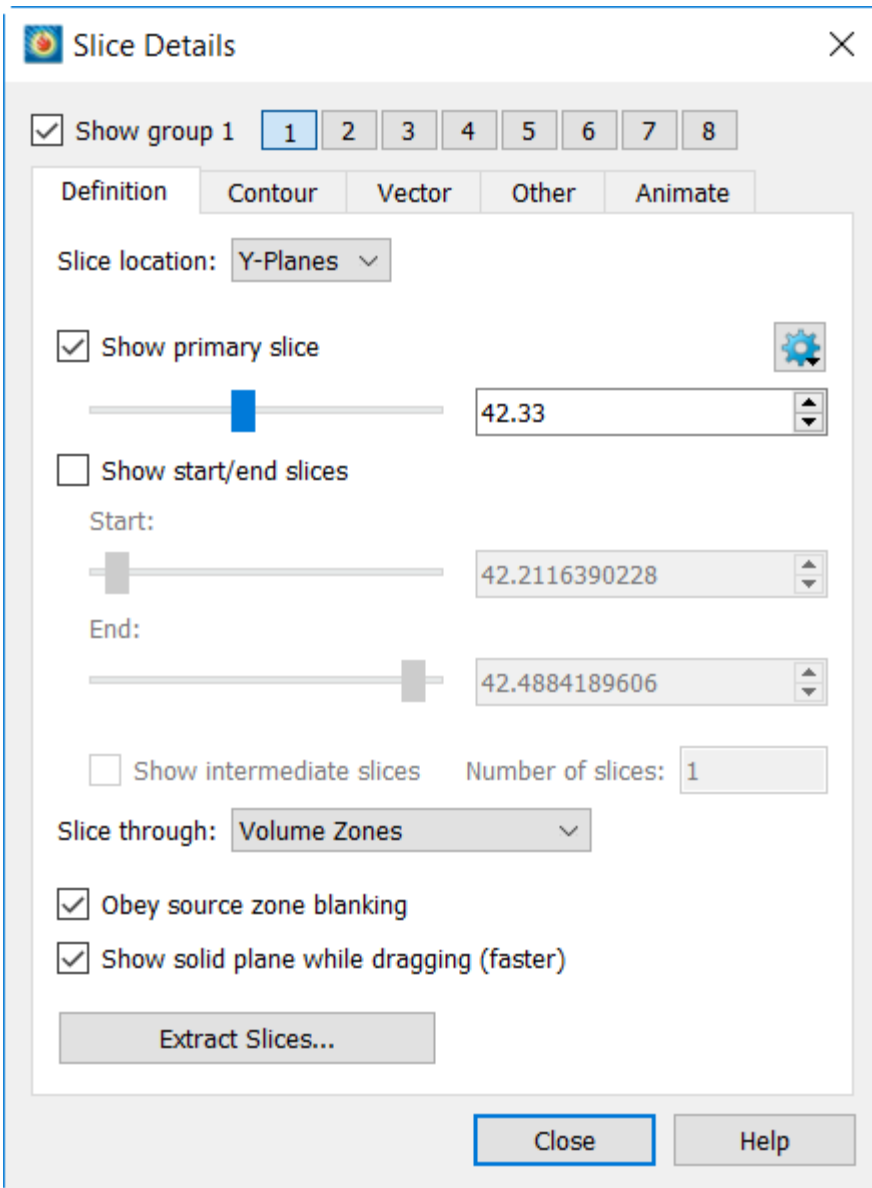

Remove the z legend by right-clicking the legend edge and selecting "Hide". Rotate the plot to see the slice easier like below.

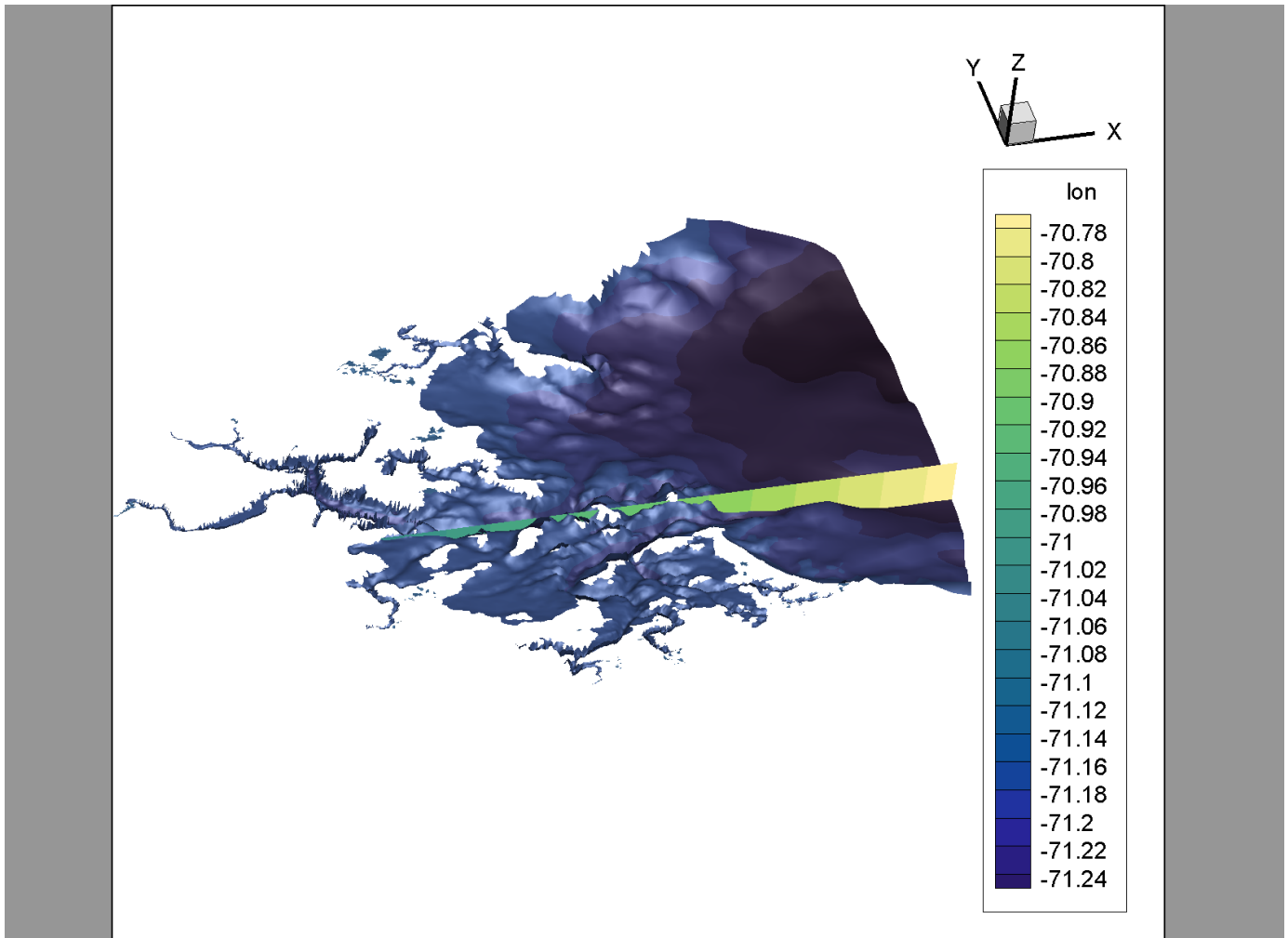

Step 4: Contour the Slice by Salinity

Now that we have a slice placed in the region of interest, we want to contour by salinity to get the salinity stratification. Click the button next to the Slice tool to bring up the Slice Details dialog. Select the Contour tab and be sure the contour group is set to 1.

If the variable is not already salinity, update the variable in the Contour Details dialog.

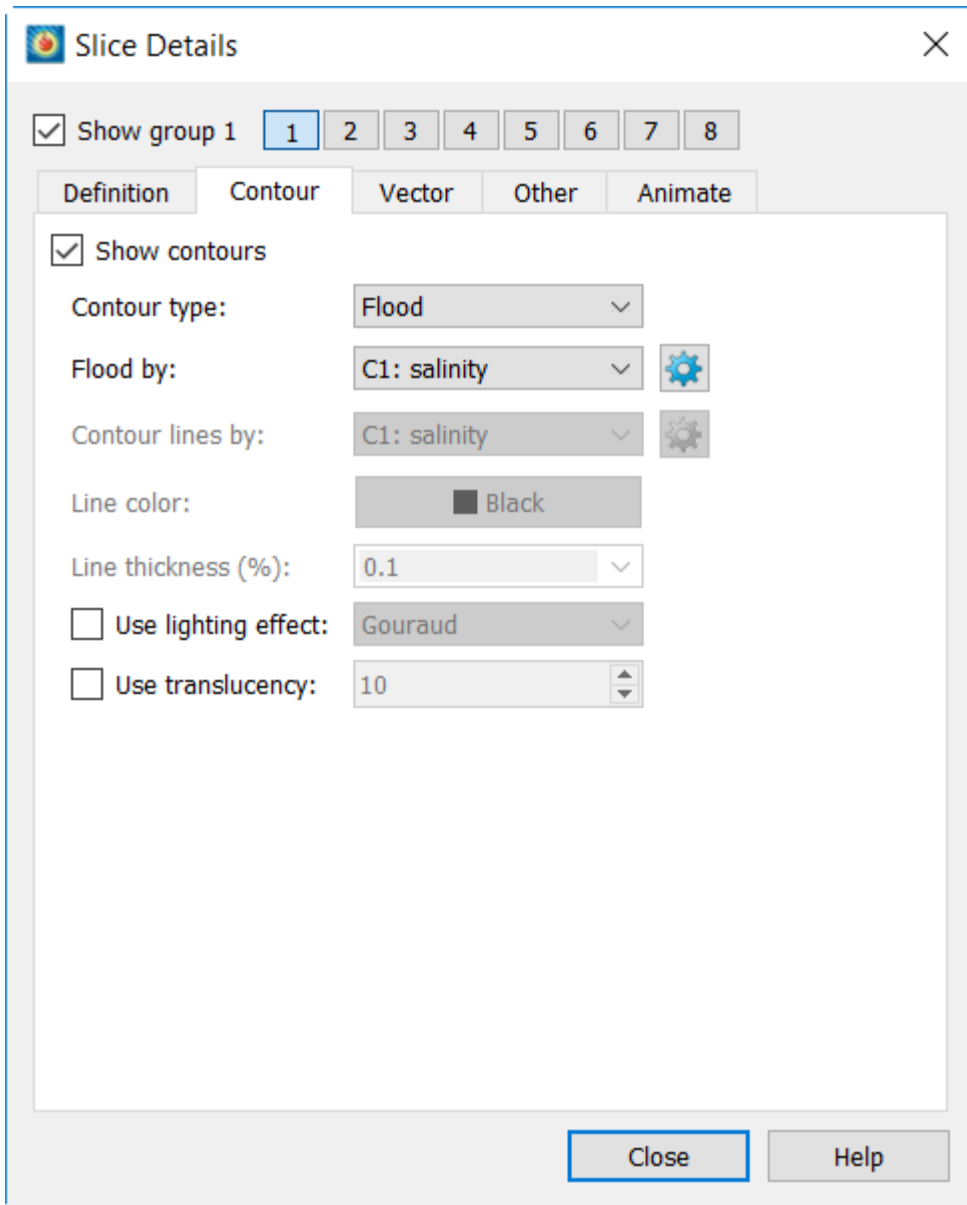

Also be sure to turn on the slice mesh in the Other tab. This will show us the final plot. The slice displays the salinity stratification through the Boston harbor. Be sure to use the zoom and pan tools to orient the plot to your liking.

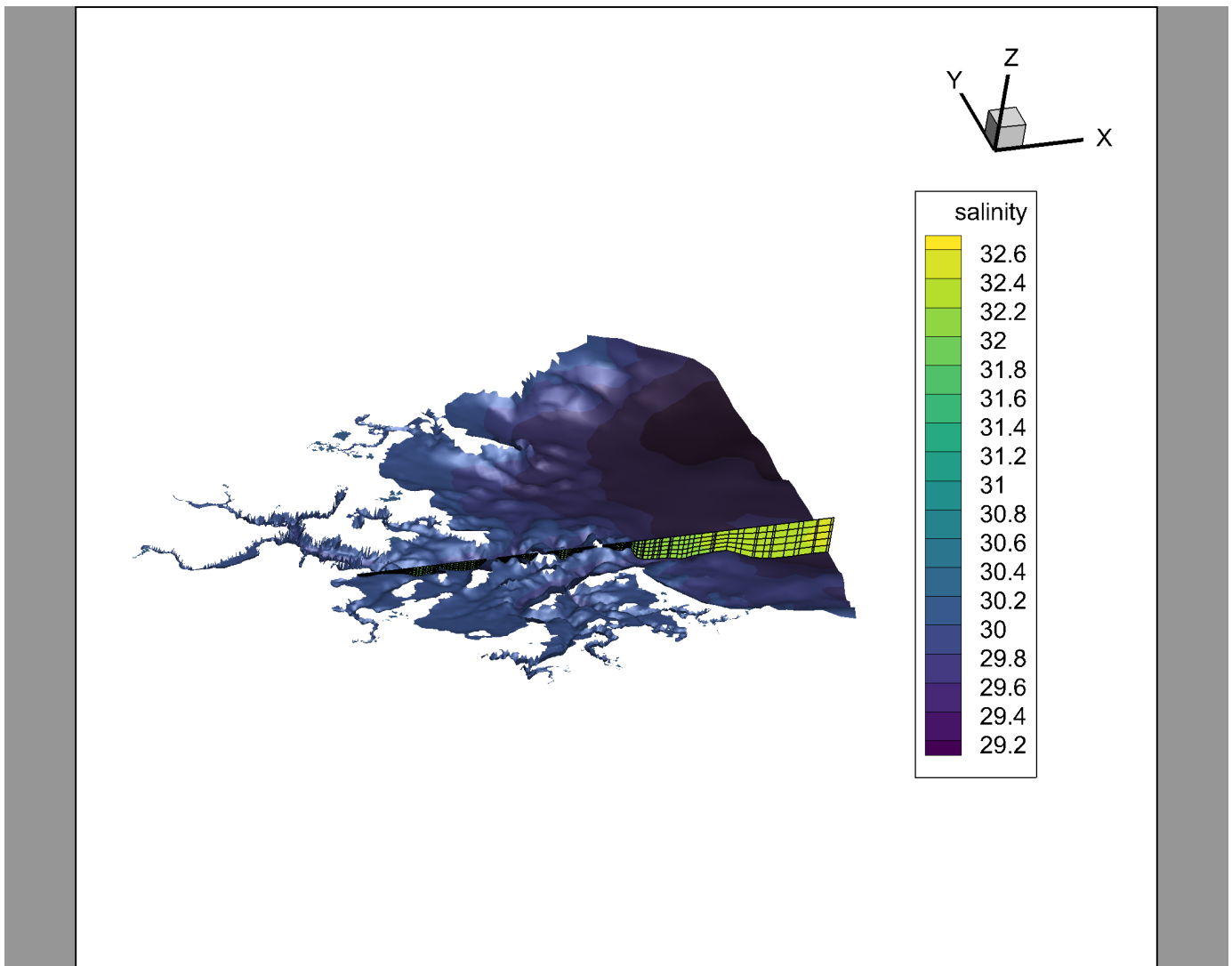

Advanced Topics

This section contains advanced topics that use Tecplot's Python API, PyTecplot, to extend the functions that the GUI provides by pairing it with Python. This allows users to increase the overall capability of Tecplot 360. Each topic will have a video containing a link to the script as well as a transcript for reference.

Vertical Transect (external video)

A vertical transect gives a curved slice extracted through time. We have created a video showing the steps to create the Vertical Transect. It is located here: www.tecplot.com/2018/10/17/vertical-transect.

Time Average (external video)

The Time Average script creates a duplicate zone with the variables averaged over time. It is located here: www.tecplot.com/2018/10/17/calculating-average-over-time.

Shapefile conversion (external video)

The Shapefile conversion script converts a shapefile into Tecplot .plt format. It is located here: www.tecplot.com/2018/10/17/converting-shapefiles-plt-using-pytecplot.

Next Steps

This concludes the Ocean Modeling tutorial for Tecplot 360. At this point, you may wish to dig in to the User's Manual or Help (**Help>Tecplot 360 Help**) for more details on the product in general or on specific features you've used in this tutorial.

We regularly create videos to introduce users to features of the product, not just introductory topics for new users, but also for advanced users and to highlight new features in the latest release. You can find these on our Web site at www.tecplot.com/category/tecplot-360-videos/?product=360 or on our YouTube channel at www.youtube.com/user/tecplot360.

Copyright

COPYRIGHT NOTICE

Tecplot 360™ Getting Started Manual is for use with Tecplot 360™ Version 2025 R2.

Copyright © 1988-2026 Tecplot, Inc. All rights reserved worldwide. Except for personal use, this manual may not be reproduced, transmitted, transcribed, stored in a retrieval system, or translated in any form, in whole or in part, without the express written permission of Tecplot, Inc., 3535 Factoria Blvd, Ste. 550; Bellevue, WA 98006 U.S.A.

The software discussed in this documentation and the documentation itself are furnished under license for utilization and duplication only according to the license terms. The copyright for the software is held by Tecplot, Inc. Documentation is provided for information only. It is subject to change without notice. It should not be interpreted as a commitment by Tecplot, Inc. Tecplot, Inc. assumes no liability or responsibility for documentation errors or inaccuracies.

Tecplot, Inc.
Post Office Box 52708
Bellevue, WA 98015-2708 U.S.A.
Tel:1.800.763.7005 (within the U.S. or Canada), 00 1 (425) 653-1200 (internationally)
E-mail: sales@tecplot.com, support@tecplot.com
Questions, comments or concerns regarding this document: support@tecplot.com
For more information, visit www.tecplot.com

THIRD PARTY SOFTWARE COPYRIGHT NOTICES

LAPACK 1992-2007 LAPACK Copyright © 1992-2007 the University of Tennessee. All rights reserved. Redistribution and use in source and binary forms, with or without modification, are permitted provided that the following conditions are met: Redistributions of source code must retain the above copyright notice, this list of conditions and the following disclaimer. Redistributions in binary form must reproduce the above copyright notice, this list of conditions and the following disclaimer listed in this license in the documentation and/or other materials provided with the distribution. Neither the name of the copyright holders nor the names of its contributors may be used to endorse or promote products derived from this software without specific prior written permission. THIS SOFTWARE IS PROVIDED BY THE COPYRIGHT HOLDERS AND CONTRIBUTORS "AS IS" AND ANY EXPRESS OR IMPLIED WARRANTIES, INCLUDING, BUT NOT LIMITED TO, THE IMPLIED WARRANTIES OF MERCHANTABILITY AND FITNESS FOR A PARTICULAR PURPOSE ARE DISCLAIMED. IN NO EVENT SHALL THE COPYRIGHT OWNER OR CONTRIBUTORS BE LIABLE FOR ANY DIRECT, INDIRECT, INCIDENTAL, SPECIAL, EXEMPLARY, OR CONSEQUENTIAL DAMAGES (INCLUDING, BUT NOT LIMITED TO, PROCUREMENT OF SUBSTITUTE GOODS OR SERVICES; LOSS OF USE, DATA, OR PROFITS; OR BUSINESS INTERRUPTION) HOWEVER CAUSED AND ON ANY THEORY OF LIABILITY, WHETHER IN CONTRACT, STRICT LIABILITY, OR TORT (INCLUDING NEGLIGENCE OR OTHERWISE) ARISING IN ANY WAY OUT OF THE USE OF THIS SOFTWARE, EVEN IF ADVISED OF THE POSSIBILITY OF SUCH DAMAGE. The University of Tennessee. All Rights Reserved. SciPy 2001-2009 Enthought, Inc. All Rights Reserved. NumPy 2005 NumPy Developers. All Rights Reserved. VisTools and VdmTools 1992-2009 Visual Kinematics, Inc. All Rights Reserved. NCSA HDF & HDF5 (Hierarchical Data Format) Software Library and Utilities Contributors: National Center for Supercomputing Applications (NCSA) at the University of Illinois, Fortner Software, Unidata Program Center (netCDF), The Independent JPEG Group (JPEG), Jean-loup Gailly and Mark Adler (gzip), and Digital Equipment Corporation (DEC). Conditions of Redistribution: 1. Redistributions of source code must retain the above copyright notice, this list of conditions, and the following disclaimer. 2. Redistributions in binary form must reproduce the above copyright notice, this list of conditions, and the following disclaimer in the documentation and/or materials provided with the distribution. 3. In addition, redistributions of modified forms of the source or binary code must carry prominent notices stating that the original code was changed and the date of the change. 4. All publications or advertising materials mentioning features or use of this software are asked, but not required, to acknowledge that it was developed by The HDF Group and by the National Center for Supercomputing Applications at the University of Illinois at Urbana-Champaign and credit the contributors. 5. Neither the name of The HDF Group, the name of the University, nor the name of any Contributor may be used to endorse or promote products derived from this software without specific prior written permission from the University, THG, or the Contributor, respectively. DISCLAIMER: THIS SOFTWARE IS PROVIDED BY THE HDF GROUP (THG) AND THE CONTRIBUTORS "AS IS" WITH NO WARRANTY OF ANY KIND, EITHER EXPRESSED OR IMPLIED. In no event shall THG or the Contributors be liable for any damages suffered by the users arising out of the use of this software, even if advised of the possibility of such damage. Copyright © 1998-2006 The Board of Trustees of the University of Illinois, Copyright © 2006-2008 The HDF Group (THG). All Rights Reserved. PNG Reference Library Copyright © 1995, 1996 Guy Eric Schalnat, Group 42, Inc., Copyright © 1996, 1997 Andreas Dilger, Copyright © 1998, 1999 Glenn Randers-Pehrson. All Rights Reserved. Tcl 1989-1994 The Regents of the University of California. Copyright © 1994 The Australian National University. Copyright © 1994-1998 Sun Microsystems, Inc. Copyright © 1998-1999 Scriptics Corporation. All Rights Reserved. bmtopnm 1992 David W. Sanderson. All Rights Reserved. Netpbm 1988 Jef Poskanzer. All Rights Reserved. Mesa 1999-2003 Brian Paul. All Rights Reserved. W3C IPR 1995-1998 World Wide Web Consortium, (Massachusetts Institute of Technology, Institut National de Recherche en Informatique et en Automatique, Keio University). All Rights Reserved. Ppmtopic 1990 Ken Yap. All Rights Reserved. JPEG 1991-1998 Thomas G. Lane. All Rights Reserved. Dired API for Microsoft Visual Studio (dired.h) 2006-2006 Copyright © 2006 Toni Ronkko. Permission is hereby granted, free of charge, to any person obtaining a copy of this software and associated documentation files (the "Software"), to deal in the Software without restriction, including without limitation the rights to use, copy, modify, merge, publish, distribute, sublicense, and/or sell copies of the Software, and to permit persons to whom the Software is furnished to do so. Toni Ronkko. All Rights Reserved. ICU 1995-2009 Copyright © 1995-2009 International Business Machines Corporation and others. All rights reserved. Permission is hereby granted, free of charge, to any person obtaining a copy of this software and associated documentation files (the "Software"), to deal in the Software without restriction, including without limitation the rights to use, copy, modify, merge, publish, distribute, and/or sell copies of the Software, and to permit persons to whom the Software is furnished to do so, provided that the above copyright notice(s) and this permission notice appear in all copies of the Software and that both the above copyright notice(s) and this permission notice appear in supporting documentation. International Business Machines Corporation and others. All Rights Reserved. QsLog 2010 Copyright © 2010, Razvan Petru. All rights reserved. QsLog Copyright © 2010, Razvan Petru. All rights reserved. Redistribution and use in source and binary forms, with or without modification, are permitted provided that the following conditions are met: Redistributions of source code must retain the above copyright notice, this list of conditions and the following disclaimer. Redistributions in binary form must reproduce the above copyright notice, this list of conditions and the following disclaimer in the documentation and/or other materials provided with the distribution. The name of the contributors may not be used to endorse or promote products derived from this software without specific prior written permission. THIS SOFTWARE IS PROVIDED BY THE COPYRIGHT HOLDERS AND CONTRIBUTORS "AS IS" AND ANY EXPRESS OR IMPLIED WARRANTIES, INCLUDING, BUT NOT LIMITED TO, THE IMPLIED WARRANTIES OF MERCHANTABILITY AND FITNESS FOR A PARTICULAR PURPOSE ARE DISCLAIMED. IN NO EVENT SHALL THE COPYRIGHT HOLDER OR CONTRIBUTORS BE LIABLE FOR ANY DIRECT, INDIRECT, INCIDENTAL, SPECIAL, EXEMPLARY, OR CONSEQUENTIAL DAMAGES (INCLUDING, BUT NOT LIMITED TO, PROCUREMENT OF SUBSTITUTE GOODS OR SERVICES; LOSS OF USE, DATA, OR PROFITS; OR BUSINESS INTERRUPTION) HOWEVER CAUSED AND ON ANY THEORY OF LIABILITY, WHETHER IN CONTRACT, STRICT LIABILITY, OR TORT (INCLUDING NEGLIGENCE OR OTHERWISE) ARISING IN ANY WAY OUT OF THE USE OF THIS SOFTWARE, EVEN IF ADVISED OF THE POSSIBILITY OF SUCH DAMAGE. Razvan Petru. All Rights Reserved. VTK 1993-2008 Copyright © 1993-2008 Ken Martin, Will Schroeder, Bill Lorensen. All rights reserved. Redistribution and use in source and binary forms, with or without modification, are permitted provided that the following conditions are met: Redistributions of source code must retain the above copyright notice, this list of conditions and the following disclaimer. Redistributions in binary form must reproduce the above copyright notice, this list of conditions and the following disclaimer in the documentation and/or other materials provided with the distribution. Neither name of Ken Martin, Will Schroeder, Bill Lorensen nor the names of any contributors may be used to endorse or promote products derived from this software without specific prior written permission. THIS SOFTWARE IS PROVIDED BY THE COPYRIGHT HOLDERS AND CONTRIBUTORS "AS IS" AND ANY EXPRESS OR IMPLIED WARRANTIES, INCLUDING, BUT NOT LIMITED TO, THE IMPLIED WARRANTIES OF MERCHANTABILITY AND FITNESS FOR A PARTICULAR PURPOSE ARE DISCLAIMED. IN NO EVENT SHALL THE AUTHORS OR CONTRIBUTORS BE LIABLE FOR ANY DIRECT, INDIRECT, INCIDENTAL, SPECIAL, EXEMPLARY, OR CONSEQUENTIAL DAMAGES (INCLUDING, BUT NOT LIMITED TO, PROCUREMENT OF SUBSTITUTE GOODS OR

SERVICES; LOSS OF USE, DATA, OR PROFITS; OR BUSINESS INTERRUPTION) HOWEVER CAUSED AND ON ANY THEORY OF LIABILITY, WHETHER IN CONTRACT, STRICT LIABILITY, OR TORT (INCLUDING NEGLIGENCE OR OTHERWISE) ARISING IN ANY WAY OUT OF THE USE OF THIS SOFTWARE, EVEN IF ADVISED OF THE POSSIBILITY OF SUCH DAMAGE. Ken Martin, Will Schroeder, Bill Lorenson. All Rights Reserved.

TRADEMARKS

Tecplot®, Tecplot 360™, the Tecplot 360 logo, Preplot™, Enjoy the View™, Master the View™, and Framer™ are registered trademarks or trademarks of Tecplot, Inc. in the United States and other countries.

3D Systems is a registered trademark or trademark of 3D Systems Corporation in the U.S. and/or other countries. Macintosh OS is a registered trademark or trademark of Apple, Incorporated in the U.S. and/or other countries. Reflection-X is a registered trademark or trademark of Attachmate Corporation in the U.S. and/or other countries. EnSight is a registered trademark or trademark of Computation Engineering International (CEI), Incorporated in the U.S. and/or other countries. EDEM is a registered trademark or trademark of DEM Solutions Ltd in the U.S. and/or other countries. Exceed 3D, Hummingbird, and Exceed are registered trademarks or trademarks of Hummingbird Limited in the U.S. and/or other countries. Konqueror is a registered trademark or trademark of KDE e.V. in the U.S. and/or other countries. VIP and VDB are registered trademarks or trademarks of Halliburton in the U.S. and/or other countries. ECLIPSE FrontSim is a registered trademark or trademark of Schlumberger Information Solutions (SIS) in the U.S. and/or other countries. Debian is a registered trademark or trademark of Software in the Public Interest, Incorporated in the U.S. and/or other countries. X3D is a registered trademark or trademark of Web3D Consortium in the U.S. and/or other countries. X Window System is a registered trademark or trademark of X Consortium, Incorporated in the U.S. and/or other countries. ANSYS, Fluent and any and all ANSYS, Inc. brand, product, service and feature names, logos and slogans are registered trademarks or trademarks of ANSYS Incorporated or its subsidiaries in the U.S. and/or other countries. PAM-CRASH is a registered trademark or trademark of ESI Group in the U.S. and/or other countries. LS-DYNA is a registered trademark or trademark of Livermore Software Technology Corporation in the U.S. and/or other countries. MSC/NASTRAN is a registered trademark or trademark of MSC Software Corporation in the U.S. and/or other countries. NASTRAN is a registered trademark or trademark of National Aeronautics Space Administration in the U.S. and/or other countries. 3DSL is a registered trademark or trademark of StreamSim Technologies, Incorporated in the U.S. and/or other countries. SDRG/IDEAS Universal is a registered trademark or trademark of UGS PLM Solutions Incorporated or its subsidiaries in the U.S. and/or other countries. Star-CCM+ is a registered trademark or trademark of CD-adapco in the U.S. and/or other countries. Reprise License Manager is a registered trademark or trademark of Reprise Software, Inc. in the U.S. and/or other countries. Python is a registered trademark or trademark of Python Software Foundation in the U.S. and/or other countries. Abaqus, the 3DS logo, SIMULIA and CATIA are registered trademarks or trademarks of Dassault Systèmes or its subsidiaries in the U.S. and/or other countries. The Abaqus runtime libraries are a product of Dassault Systèmes Simulia Corp., Providence, RI, USA. © Dassault Systèmes, 2007 FLOW-3D is a registered trademark or trademark of Flow Science, Incorporated in the U.S. and/or other countries. Adobe, Flash, Flash Player, Premier and PostScript are registered trademarks or trademarks of Adobe Systems, Incorporated in the U.S. and/or other countries. AutoCAD and DXF are registered trademarks or trademarks of Autodesk, Incorporated in the U.S. and/or other countries. Ubuntu is a registered trademark or trademark of Canonical Limited in the U.S. and/or other countries. HP, LaserJet and PaintJet are registered trademarks or trademarks of Hewlett-Packard Development Company, Limited Partnership in the U.S. and/or other countries. IBM, RS/6000 and AIX are registered trademarks or trademarks of International Business Machines Corporation in the U.S. and/or other countries. Helvetica Font Family and Times Font Family are registered trademarks or trademarks of Linotype GmbH in the U.S. and/or other countries. Linux is a registered trademark or trademark of Linus Torvalds in the U.S. and/or other countries. ActiveX, Excel, Microsoft, Visual C++, Visual Studio, Windows, Windows Metafile, Windows XP, Windows Vista, Windows 2000 and PowerPoint are registered trademarks or trademarks of Microsoft Corporation in the U.S. and/or other countries. Firefox is a registered trademark or trademark of The Mozilla Foundation in the U.S. and/or other countries. Netscape is a registered trademark or trademark of Netscape Communications Corporation in the U.S. and/or other countries. SUSE is a registered trademark or trademark of Novell, Incorporated in the U.S. and/or other countries. Red Hat is a registered trademark or trademark of Red Hat, Incorporated in the U.S. and/or other countries. SPARC is a registered trademark or trademark of SPARC International, Incorporated in the U.S. and/or other countries. Products bearing SPARC trademarks are based on an architecture developed by Sun Microsystems, Inc. Solaris, Sun and SunRaster are registered trademarks or trademarks of Sun Microsystems, Incorporated in the U.S. and/or other countries. Courier is a registered trademark or trademark of Monotype Imaging Incorporated in the U.S. and/or other countries. UNIX and Motif are registered trademarks or trademarks of The Open Group in the U.S. and/or other countries. Qt is a registered trademark or trademark of Digia PLC in the U.S. and/or other countries. Zlib is a registered trademark or trademark of Jean-loup Gailly and Mark Adler in the U.S. and/or other countries. OpenGL is a registered trademark or trademark of Silicon Graphics, Incorporated in the U.S. and/or other countries. JPEG is a registered trademark or trademark of Thomas G. Lane in the U.S. and/or other countries. SENSOR is a registered trademark or trademark of Coats Engineering in the U.S. and/or other countries. SENSOR is licensed and distributed only by Coats Engineering and by JOA Oil and Gas, a world-wide authorized reseller. All other product names mentioned herein are trademarks or registered trademarks of their respective owners.

NOTICE TO U.S. GOVERNMENT END-USERS

Use, duplication, or disclosure by the U.S. Government is subject to restrictions as set forth in subparagraphs (a) through (d) of the Commercial Computer-Restricted Rights clause at FAR 52.227-19 when applicable, or in subparagraph (c)(1)(ii) of the Rights in Technical Data and Computer Software clause at DFARS 252.227-7013, and/or in similar or successor clauses in the DOD or NASA FAR Supplement. Contractor/manufacturer is Tecplot, Inc., 3535 Factoria Blvd, Ste. 550; Bellevue, WA 98006 U.S.A.

Part Number: 21-360-02-2 Build Revision 85213

Released: 10/2021