



tecplot. focus

Release Notes
Tecplot Focus 2025 R2
Maintenance Release 1

Tecplot, Inc.

Copyright © 1988-2026 Tecplot, Inc. All rights reserved worldwide. See the complete [legal notice](#) in the copyright section of this document.

Introduction

This release introduces our new **Vulkan**-based graphics engine, a major step forward in performance, visual quality, and platform longevity. As simulation sizes continue to grow, and engineers demand more responsive visualization, we've built a modern rendering engine that makes post-processing faster, smoother, and more future proof.

With this update, users can expect 3x to 400x faster graphics, especially with large, complex datasets. A new GPU-based Order-Independent Transparency (OIT) pipeline, enhanced lighting modes, improved particle rendering, GPU-based vector arrowhead billboarding and Multi-Sampled Anti-Aliasing (MSAA) deliver a step-change in interactive performance. This is the foundation for years of innovation to come.

This new graphics engine has been designed and tested to operate on all environments supported by Tecplot Focus, whether you have a discrete, integrated or virtual GPU. Or even if you're running software rendering on a CPU. For best performance, we recommend that you run Tecplot Focus on a system equipped with a discrete GPU and the latest native drivers installed.

Faster Graphics

The most significant benefit of the new Vulkan-based rendering engine is a substantial increase in graphics performance across all platforms. All users should notice faster, smoother visualization, especially when working with large datasets or complex scenes that previously pushed the limits of graphics cards.

These improvements can be felt in many aspects of interaction, such as rotating, zooming, and panning views. An easy way to quantify them is by measuring frame rate performance during view transformations. A quantitative comparison has been performed for various datasets and compared to the previous release. Some speedup examples are summarized in the chart below.

Rendering Speedup (Tecplot 360 2025 R2 Vs. Previous)

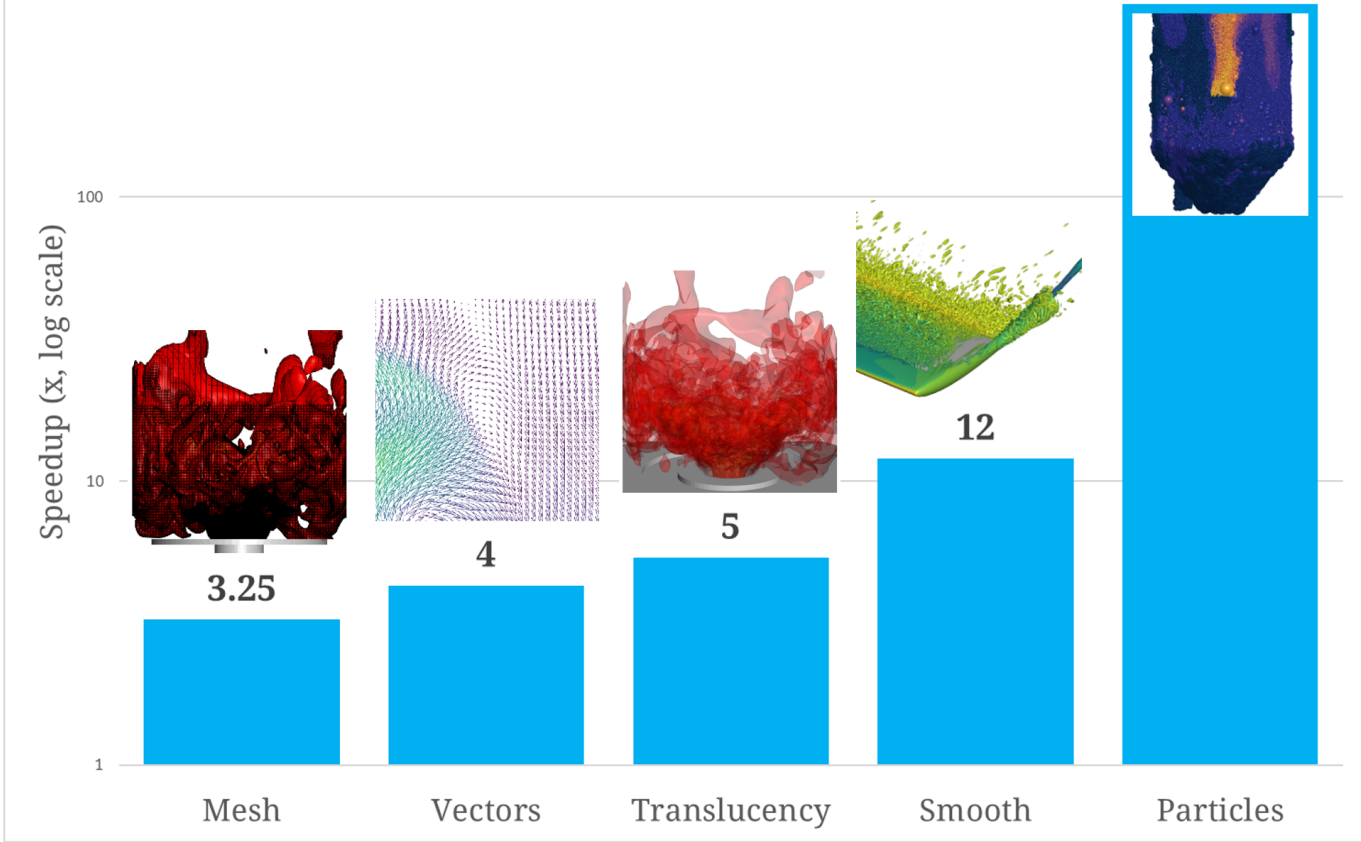

Faster Translucency with GPU-accelerated OIT

This release introduces GPU-accelerated Order Independent Transparency (OIT), a modern rendering technique that not only produces accurate transparency for a high number of overlapping surfaces but also delivers substantial performance gains.

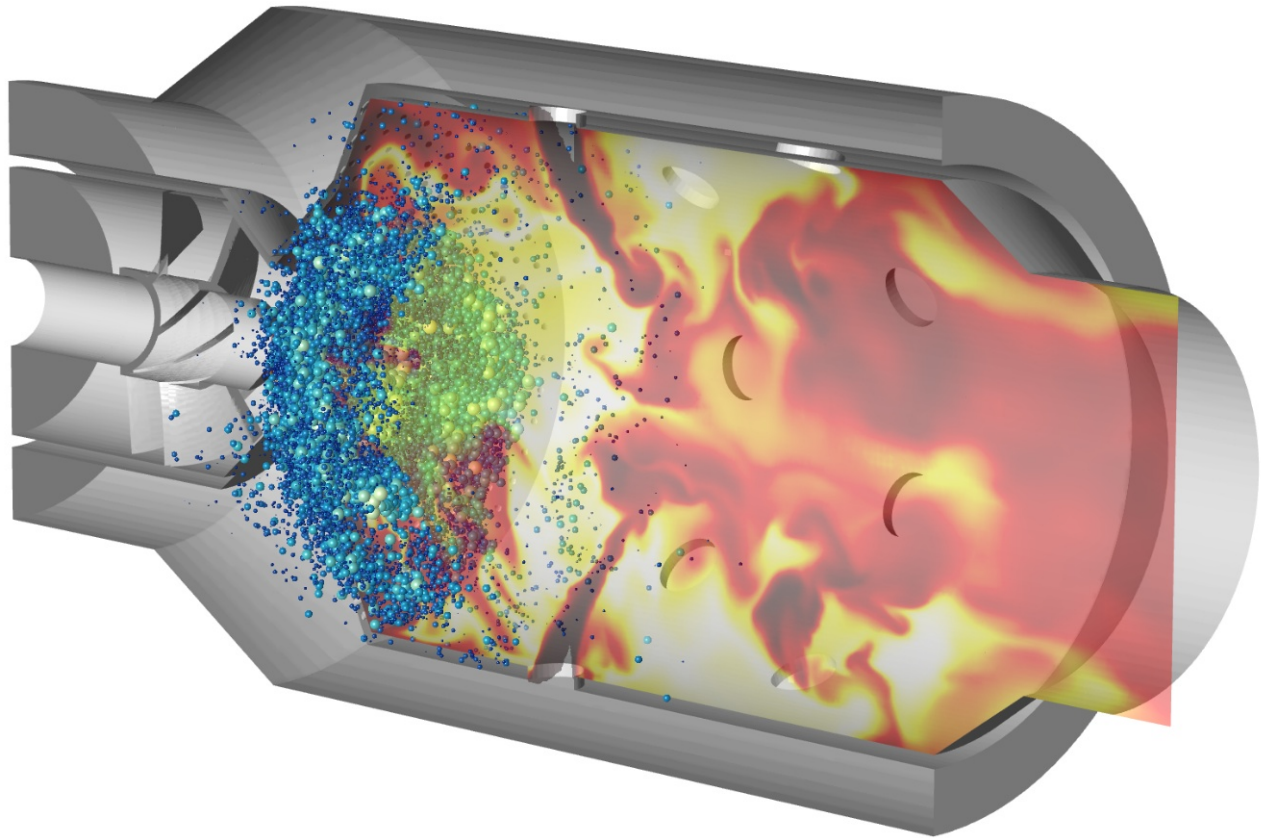

Previous Tecplot Focus releases continuously sorted the scene elements on the CPU to achieve the transparency effect during interactive rotations. This became a bottleneck for large meshes with many overlapping surfaces and resulted in incorrect plots when rotated too far as it caused the sorted elements to be rendered in the wrong order. In addition, intersections between surfaces were processed per-triangle instead of per-pixel even though only a portion of a triangle may be below another (see figure below).

By moving transparency compositing onto the GPU and performing it at the pixel level, Tecplot Focus can now handle far more layers of transparency per pixel without lag. Rotations and zooms remain smooth even with transparency-heavy scenes. Transparent iso-surfaces and contour planes appear cleaner, with fewer visual artifacts. Large 3D datasets that previously felt “heavy” when translucency was enabled are now much more responsive.

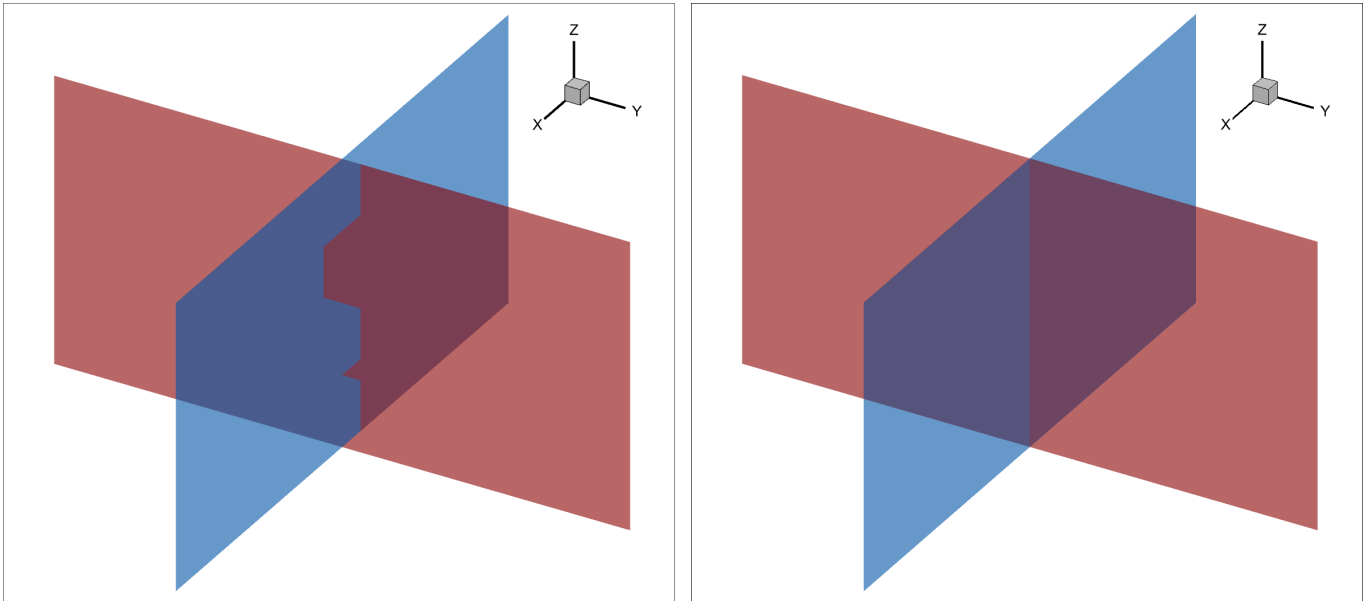
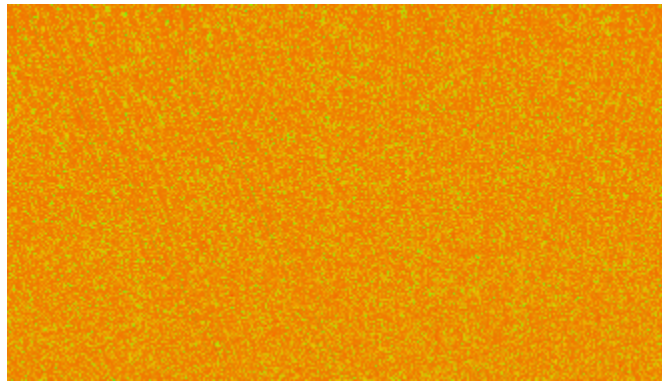

Figure 1. Comparison between transparency in previous versions of Tecplot Focus (left) and with the new GPU-accelerated OIT technique (right). Note how the previous ordering method could cause intersecting surfaces to be incorrectly represented.

No rendering technique is perfect, particularly when designed to succeed on the wide range of environments supported by Tecplot Focus (discrete, integrated or virtual GPU, software rendering on the CPU). When rendering scenes that are pushing your system to its graphics limits (very large resolution, hundreds of overlaid faces, etc.), transparency artifacts may appear, taking the form of “noisy” or “grainy” rendering, with pixels showing what could seem like arbitrary colors (see example below).



Such artifacts are more likely to appear during view transforms, as Tecplot Focus will temporarily reduce the number of transparent layers being ordered to prioritize performance. Once the view transform is complete, the number of sorted layers will be raised to prioritize image quality again.

Another artifact can look like portions of a transparent surface are disappearing.

If you experience any of these problems, you may adjust one or more of Tecplot Focus’s three new OIT configuration settings found in the `tecplot.cfg` file located in the top-level directory of your installation. New values will take effect on the next startup of the application.

```
#!/Interface VulkanConfig { OnScreenDevice { OITSettings { MinSortedFragmentCount = 128}}}
```

This sets number of fragments sorted during interactive view changes. Default: 128. Valid range: 1 to 1024. Must be less or equal to `MaxSortedFragmentCount`. Lower this setting for smoother view changes. Raise it for higher quality.

```
#!/Interface VulkanConfig { OnScreenDevice { OITSettings { MaxSortedFragmentCount = 1024}}}
```

This sets number of fragments sorted when the view is stationary. Default: 1024. Valid range: 1 to 4096. Lower this setting for a faster fixed view. Raise it for higher quality.

```
#!/Interface VulkanConfig { OnScreenDevice { OITSettings { FragmentBufferSize = 512}}}
```

This sets size of the memory buffer (in MiB) used to sort fragments. Default: 512. Valid range: 10 to 10000. If portions of transparent surfaces are disappearing or if raising `MaxSortedFragmentCount` has no effect, try increasing the size of the memory buffer. As a general rule, it is recommended to keep it well below the dedicated memory of your GPU.

New Lighting Effects and Smoother Specular Highlights

This release introduces two new lighting effects, **Smooth** and **Smooth with Creases**, as a replacement for **Gouraud**. It also includes improvements to **Paneled** for better performance. Starting with this release, options include:

- **Paneled**: this option is identical visually to the one already available in previous versions, but it has been optimized for better performance. Because it uses a single normal per face, it will result in the best performance of all three options. It is used by default for Slices.

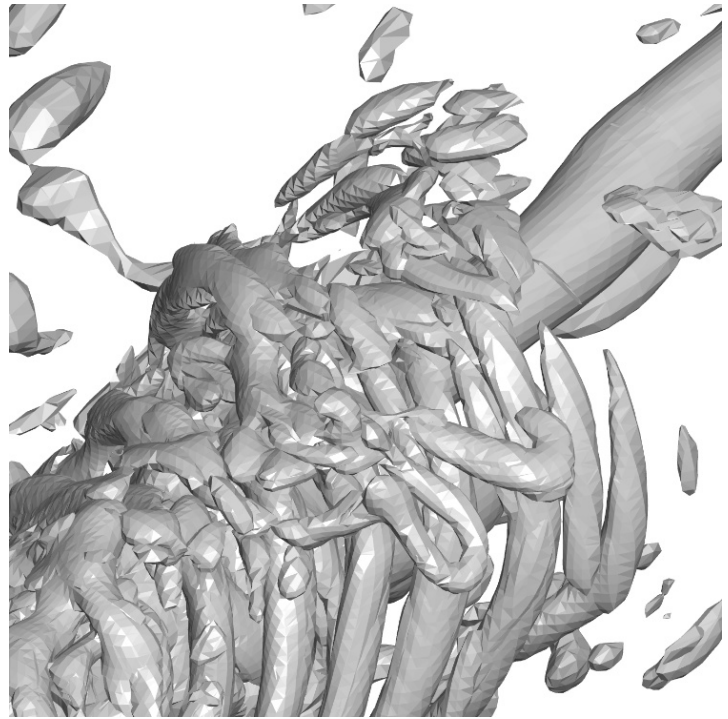
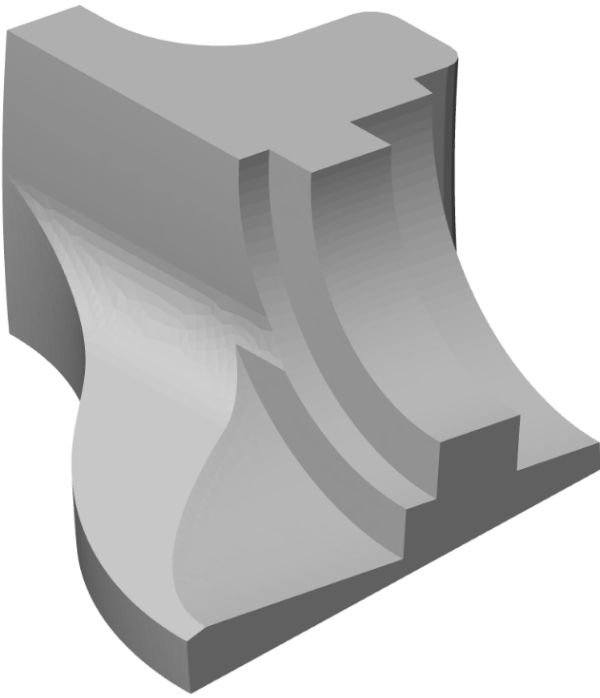

- **Smooth with Creases:** this new option uses an interpolation of face normals, which then gets used in lighting being computed per pixel (a method called Phong lighting). It is an improvement from the former **Gouraud** lighting option, with which lighting was only calculated at the nodes prior to being interpolated across faces (for a comparison between Phong and Gouraud, see the image later in this section). When the angle between two consecutive faces exceeds a prescribed angle (135 deg by default - This value can be changed via the **Edge Details** dialog, accessed from the Plot sidebar), a crease is represented between the faces.

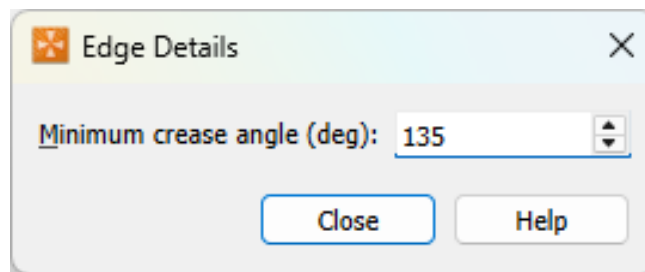

This makes **Smooth with Creases** the preferred option for accurately representing Zones with complex shapes. It is therefore used by default for Zones and Streamtrace Rods. It should be noted that it is the slowest of the three modes, although it is much faster than **Gouraud** as computed in previous releases.

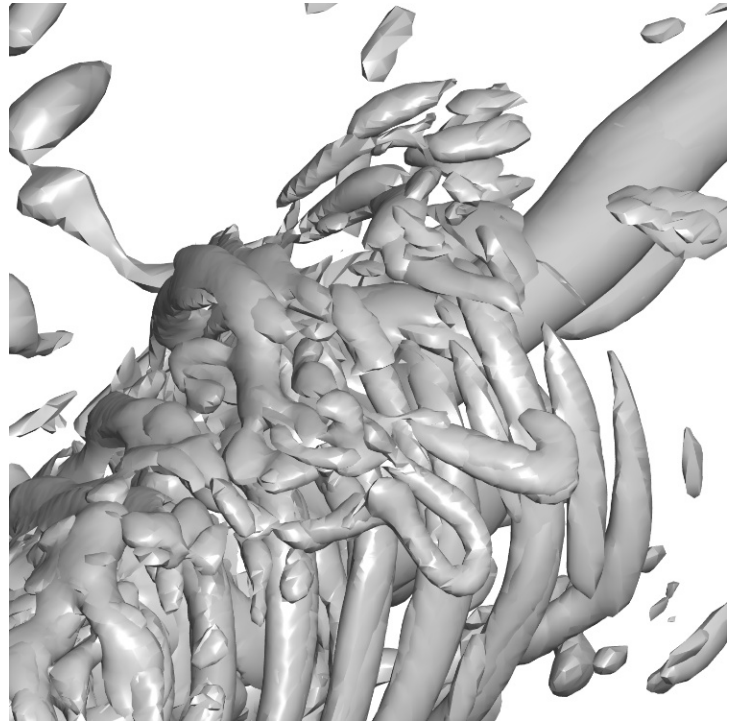
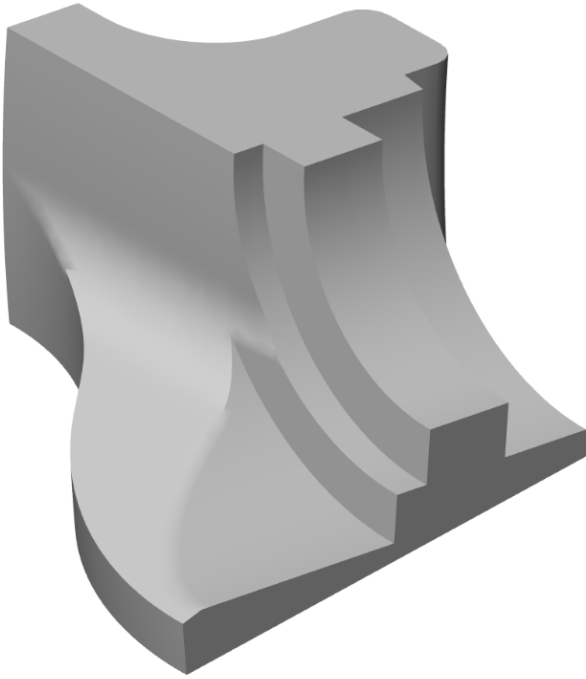

- **Smooth:** this new option uses the same Phong lighting as **Smooth with Creases**, but with the creases computation being skipped. This results in better performance than **Smooth with Creases**, and a lighting effect that is more suitable for surfaces for which no crease is expected (such as the Iso-Surface of turbulence shown in the bottom right image). It is the default setting for Iso-Surfaces.

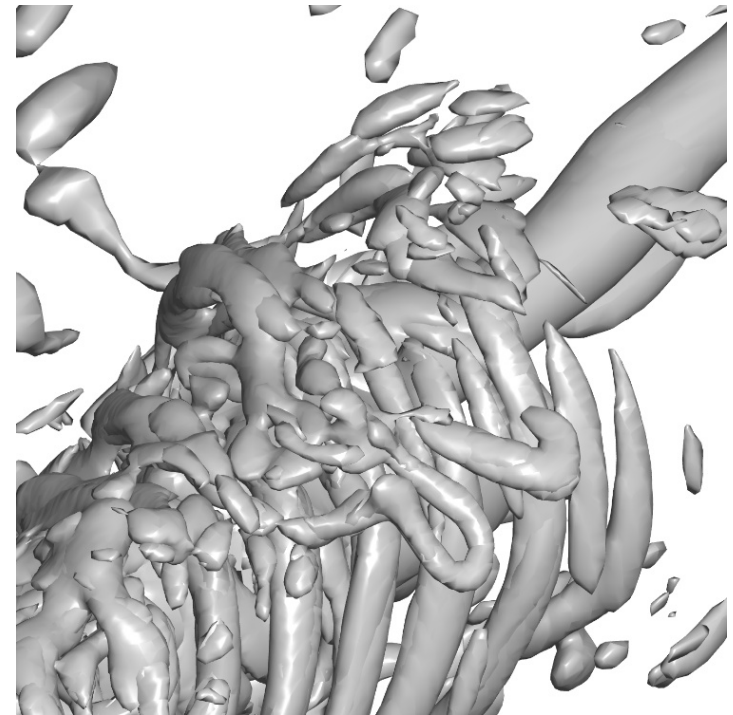
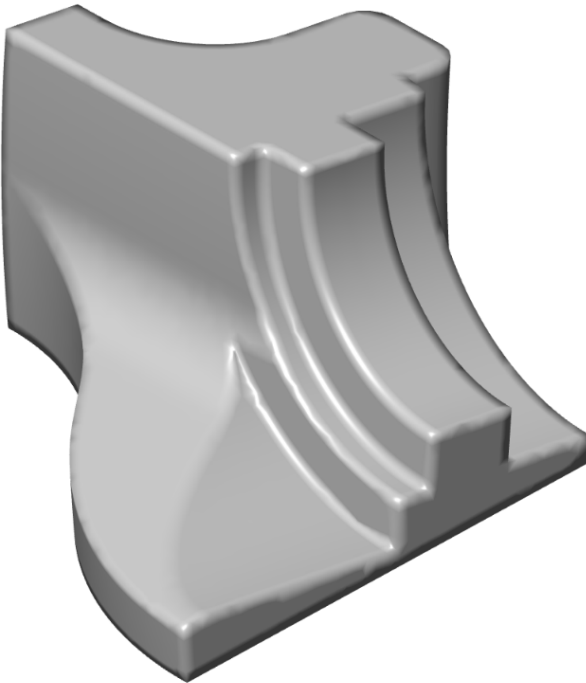

Images below show each of Tecplot Focus's lighting effects on more detailed Zones.

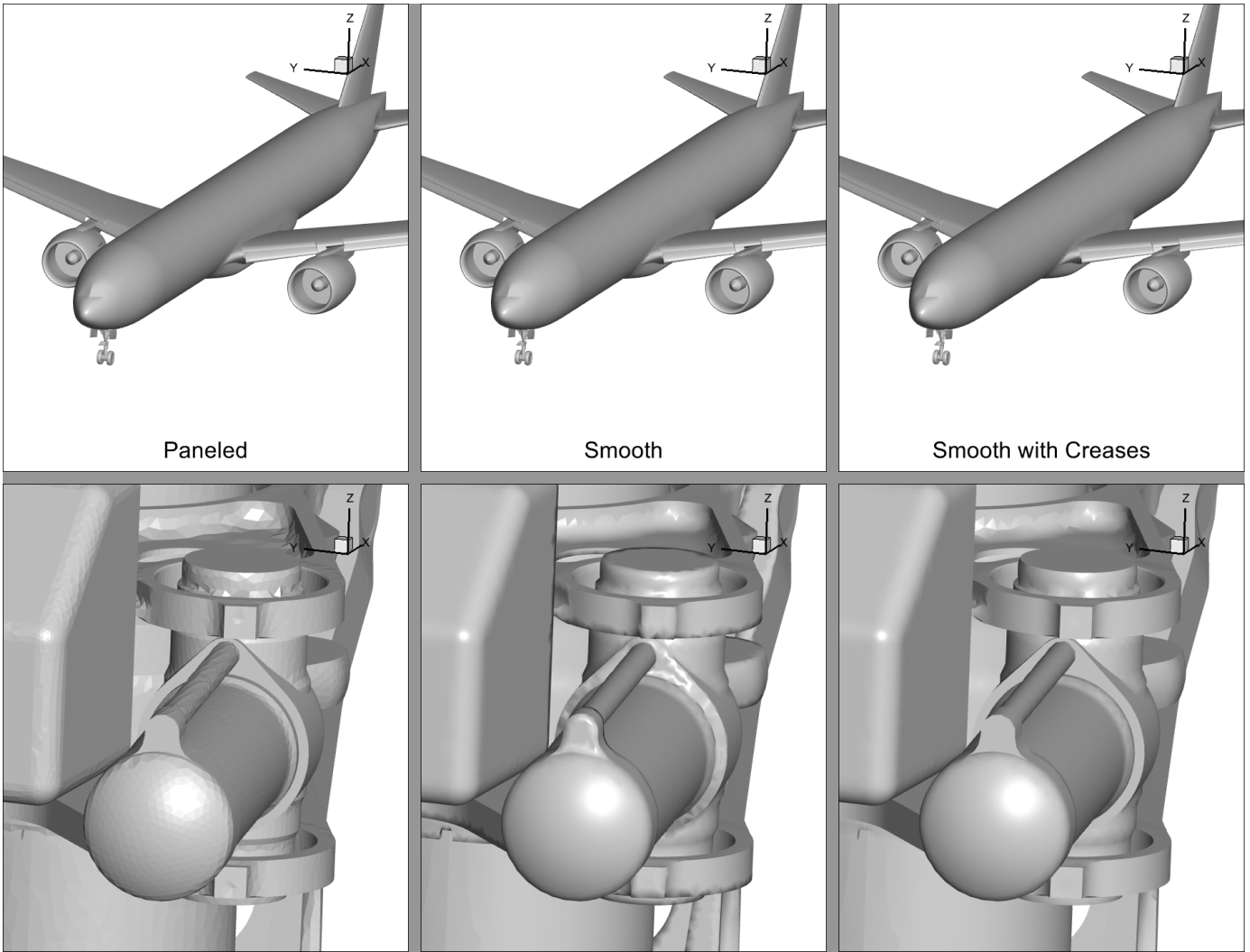

Finally, the figure below shows a comparison between Gouraud, available in previous releases, and Smooth, which is now leveraging Phong lighting. The difference is particularly visible with Specular Highlights ON, when zooming in closely on a surface or when working with coarse meshes.

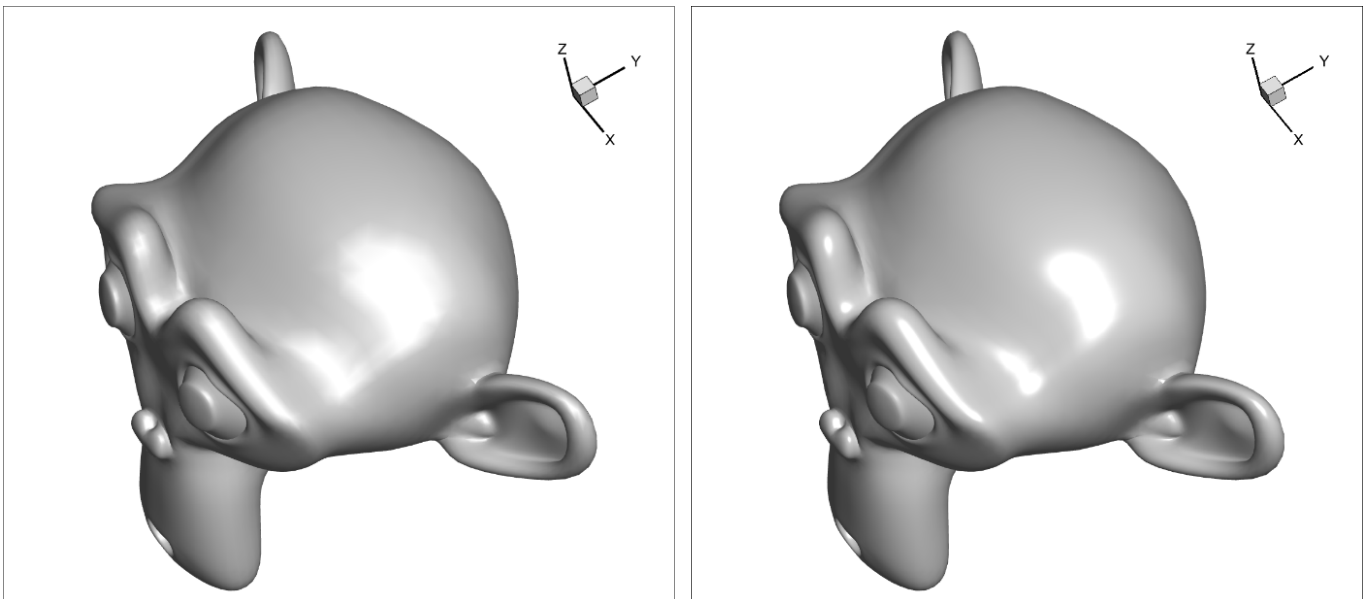
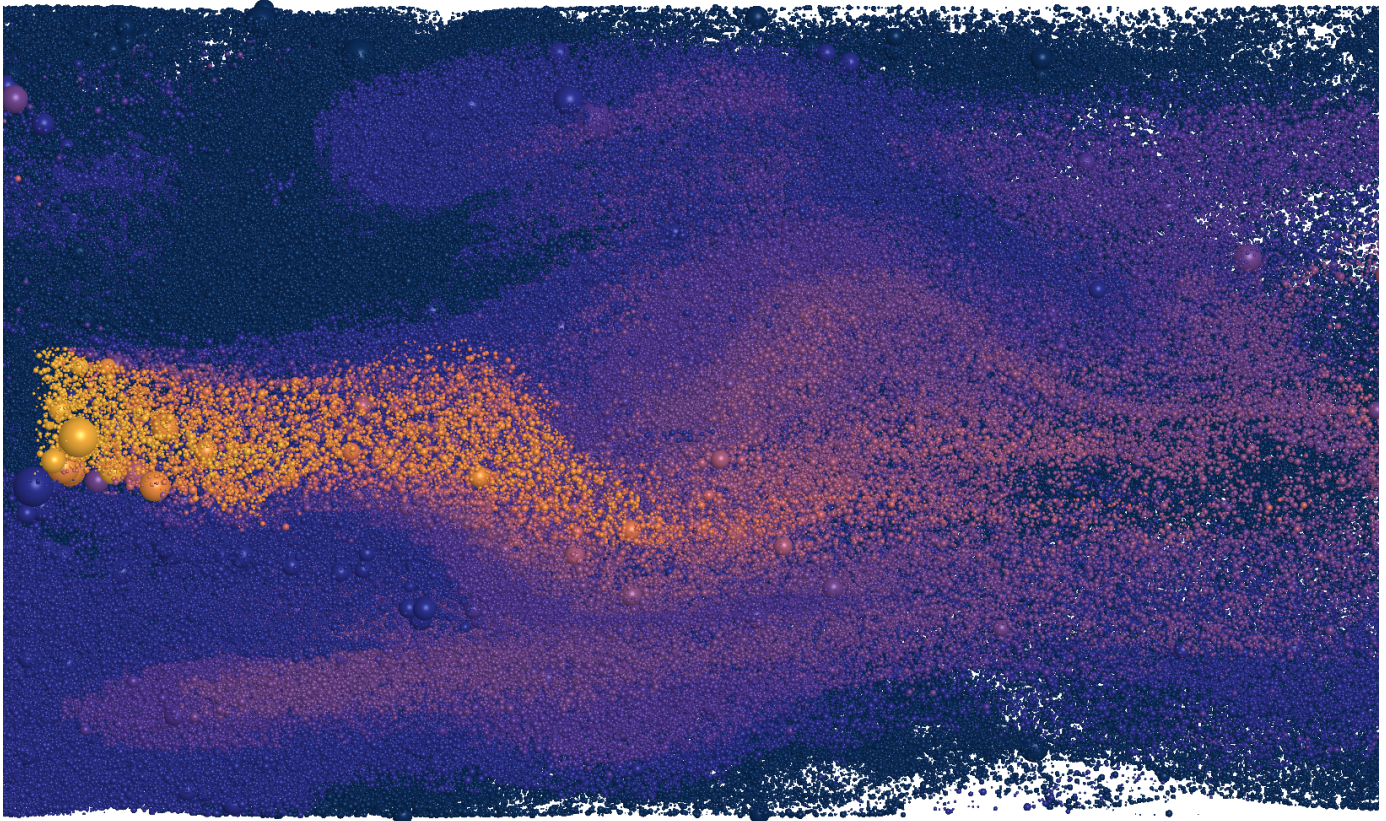

Figure 2. Specular highlight from previous Tecplot Focus versions using Gouraud shading (left) compared to the new Phong shading (right). Note the more realistic highlight.

Faster Particle Rendering

Rendering of scatter symbols has been drastically improved in this release of Tecplot Focus, particularly the rendering of sphere symbols (480x faster for the case reported in the section above). In this release we introduce a new `SphereScatterRenderQuality` setting: **FAST**, which is also the new default.



The rendering quality of spheres may be changed in the Tecplot configuration file (`tecplot.cfg`) using this command:

```
$!GlobalScatter SphereScatterRenderQuality = [LOW|MEDIUM|HIGH|FAST]
```

Faster Vectors with GPU-Based Billboarding

GPU-based vector arrowhead billboarding keeps vector arrowheads visually clear by rendering each arrowhead as a camera-facing shape computed on the GPU. Instead of using fully modeled 3D arrowhead geometry, Tecplot Focus orients the arrowhead flat to the screen so it always faces the viewer, maintaining a consistent silhouette and readable shape regardless of camera angle. Because orientation and sizing are handled per arrow in GPU shaders, this approach scales efficiently to large

vector fields, improving both performance and visual legibility, especially during interactive rotation.

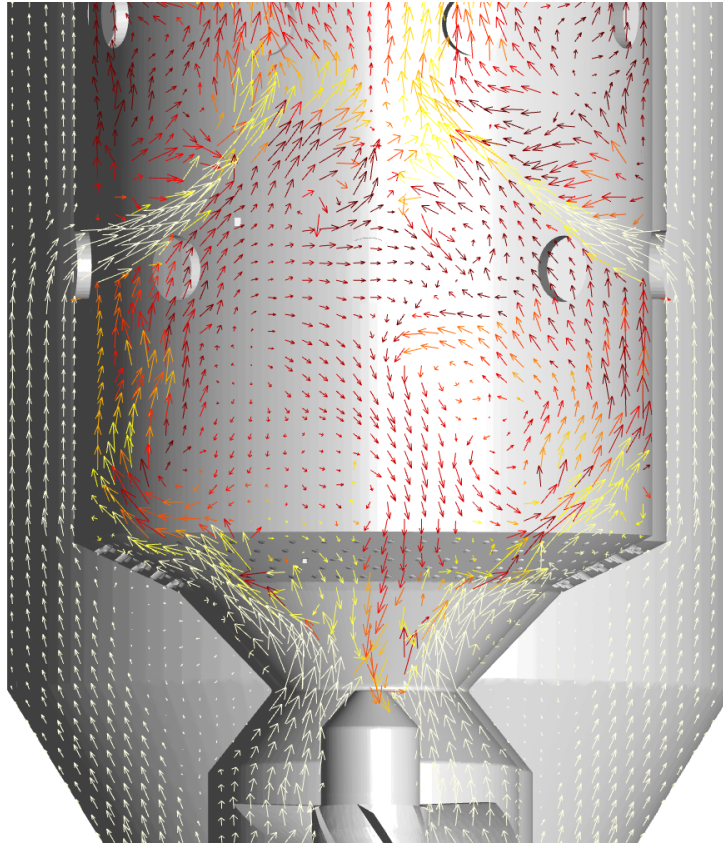

Multi-Sampling Anti-Aliasing

This release upgrades our anti-aliasing technology by replacing the older Super-Sampling Anti-Aliasing (SSAA) method with Multi-Sampling Anti-Aliasing (MSAA). While SSAA produced smooth edges, it did so at a significant performance cost by rendering scenes at higher resolutions and then downscaling.

MSAA achieves similar edge-smoothing quality with a far more efficient approach. The result is sharper, cleaner images with much lower GPU load, allowing users to enjoy smoother visuals without sacrificing rendering speed.

By default, a sampling level of 4 is used for both interactive and offscreen rendering (used to save images and animations). It provides a good balance of performance, GPU memory and quality. For users who still want control over the MSAA sampling level, two new settings are available in the Tecplot configuration file (`tecplot.cfg`), located in the top-level directory in your installation. These values will be checked at startup.

```
#!/Interface VulkanConfig { OnScreenDevice { MaxMultiSamples = <integer> }}
```

This sets the number of desired multi-samples used for on-screen rendering. The range of values are powers of 2 between 0 and 64. If a value of 0 or 1 is supplied, no multi-sampling is performed. Larger values of multi-sampling produce smoother lines but require more GPU memory, which may not be

supported on your GPU. The default value is 4.

```
#!/Interface VulkanConfig { OffScreenDevice { MaxMultiSamples = <integer> }}
```

This sets the number of desired multi-samples used for off-screen rendering. Identical to the setting for on screen rendering otherwise.

The figure below shows their effect on a close-up view. Values above 4 produce only a very subtle change, which is why it has been selected as the default.

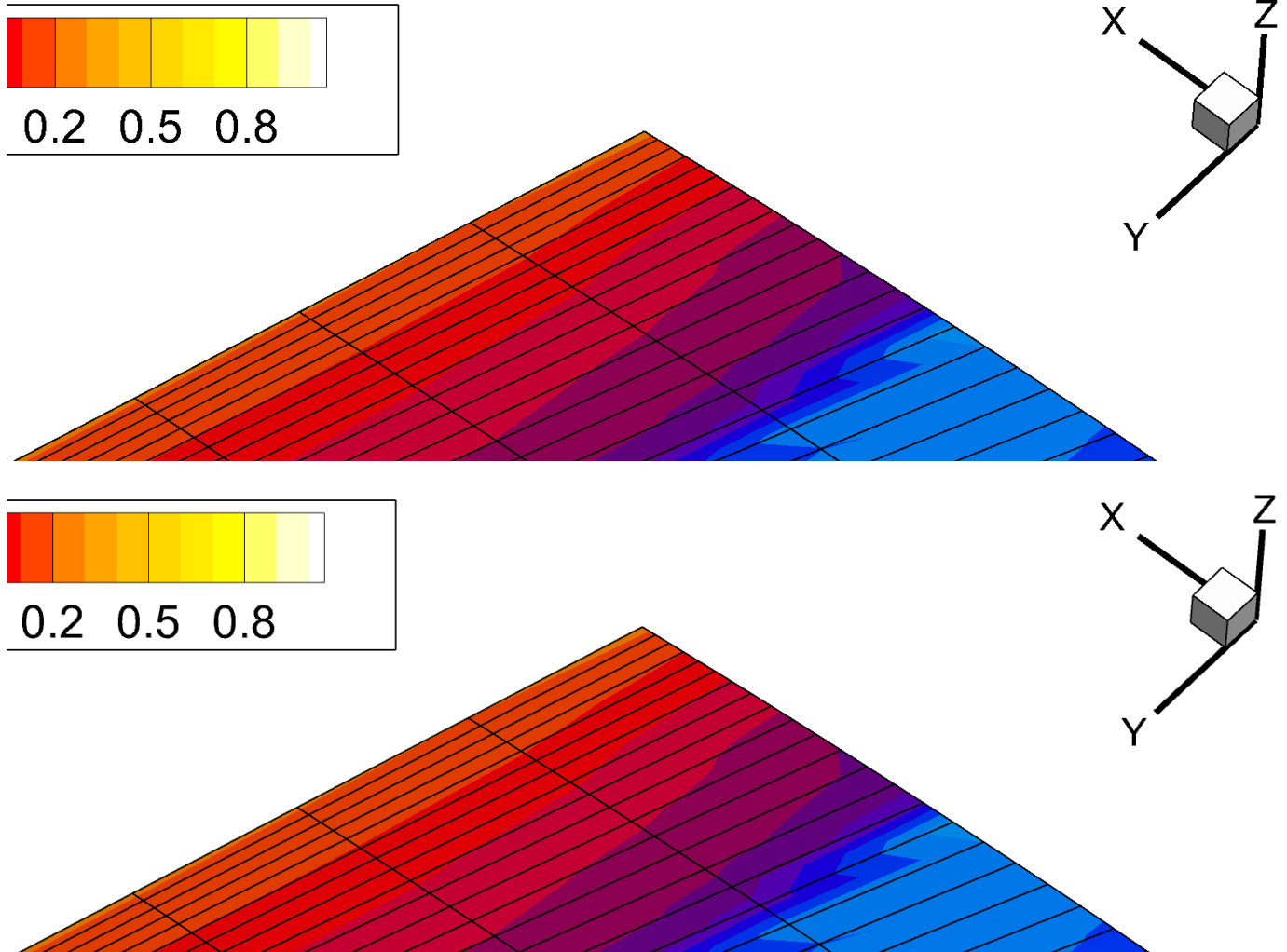

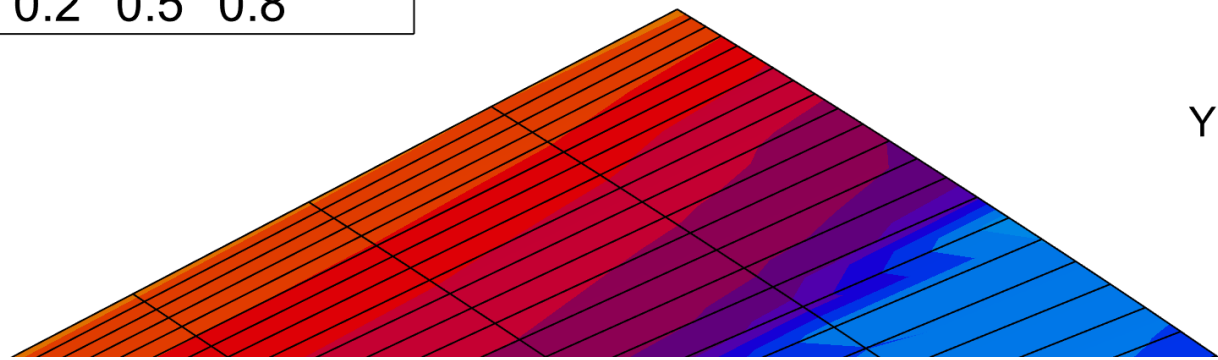
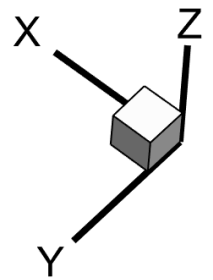
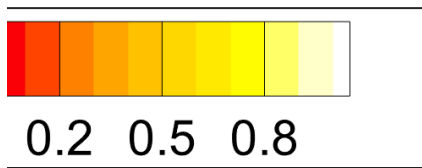
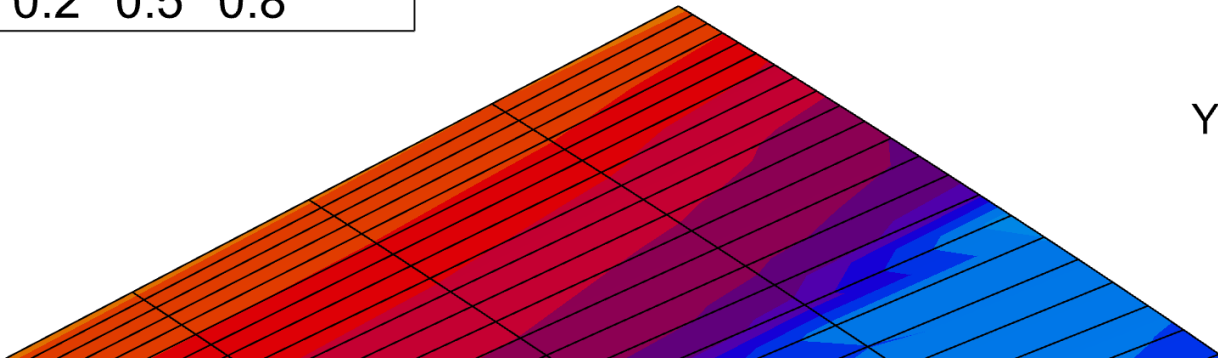
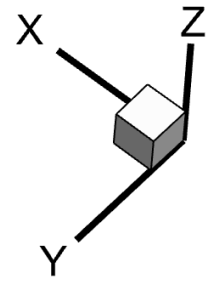
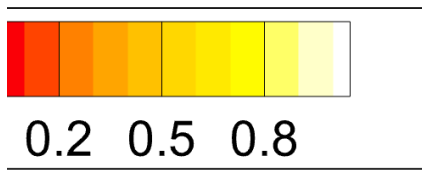

Close-up view of MSAA level 1, 2, 4 (default) and 8 (from top to bottom)

Vulkan Support Across Various Configurations

Built on the Vulkan API, the new graphics engine delivers consistent performance across multiple platforms and hardware configurations. Vulkan’s wide industry support—from GPU and driver vendors to operating systems—ensures reliable rendering whether running on Windows, Linux, or macOS. We recommend keeping your graphics drivers up to date, as Vulkan continues to evolve through active development.

Windows systems support Vulkan out of the box. On macOS, Tecplot Focus uses a runtime library that maps Vulkan to Apple’s Metal graphics framework. On Linux, Vulkan support depends on the distribution—if it’s not already installed, you may need to add the appropriate Vulkan packages or drivers manually.

To help you quickly confirm Vulkan compatibility and version details, the **Help** → **About Tecplot Focus** panel will display your system’s runtime environment information after a first plot has been rendered.

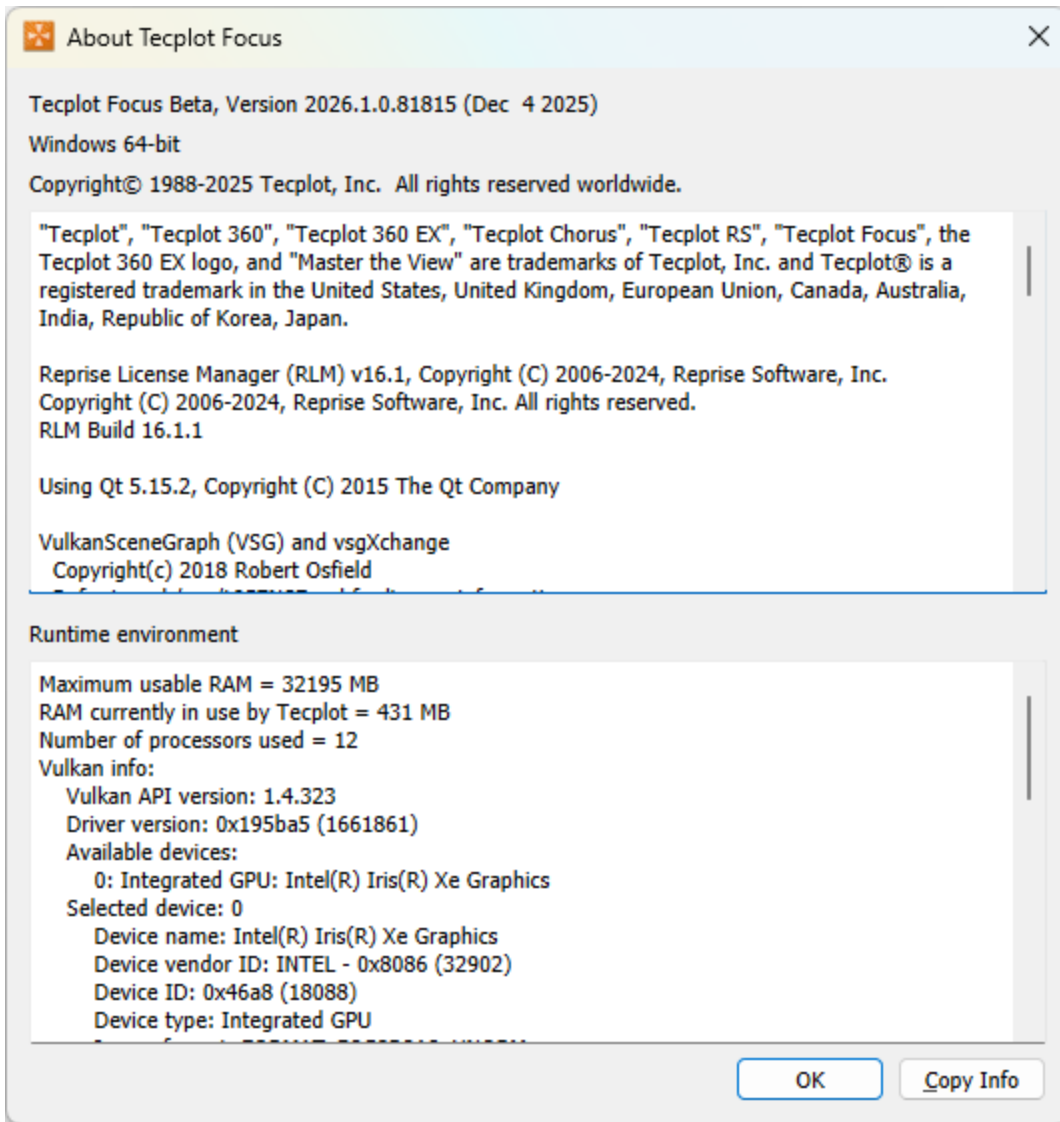

If your system has multiple GPUs, you can select the one being used by Tecplot Focus thanks to a new setting in the Tecplot configuration file (`tecplot.cfg`):

```
#!Interface VulkanConfig { GpuNumber = <integer> }
```

The default setting is -1, indicating that Tecplot chooses. GPU numbers range from 0 to `<numdevices>-1`.

The same can be achieved with the command line option `--gpu-number <integer>`.

Software Rendering is supported through Mesa's LLVM driver. Naturally, this will be much slower than running with Hardware Rendering, but may be a valid workaround when a GPU is not available or has buggy drivers.

On Linux, you can force Tecplot Focus to use Tecplot's LLVM Mesa Vulkan drivers by using the `--mesa` command line option. For RedHat 8 in particular, the default Linux drivers do not support Mesa and this will be the only option for using software rendering.

Other Updates & Improvements

2025 R2

- Fixed failures to launch Tecplot Focus when double clicking on a layout file in international Windows OS File Explorer.

List of resolved issues

2025 R2

- Fixed crash when changing a value in an input field and clicking the Close button without first tabbing out of the input field. This also fixed the issue of plots being left in the "Drawing Interrupted" state after clicking the Close button without first tabbing out of the input field.
- Fixed macro recording of layout opening operations to no longer contain alternative load instructions if the file data override was not used.

2025 R2 M1

- Fixed crash when computing Green-Gauss derivatives when element dimension doesn't match the frame dimension. In this scenario, the derivatives are computed using Moving Least Squares even when Green-Gauss is selected.
- Fixed an issue where plot mesh lines did not scale automatically when changing the axis range if axis dependency is set to Independent.
- Fixed crash when selecting grid variable for cell labels of a FE-volume zone.
- Fixed crash when drawing vertical or horizontal polylines using the Create Polylines geometry tool.
- Fixed issue with pick handles not rendering and moved objects not showing where they have moved to when auto-redraw is turned off. If the Redraw button was pressed or auto-redraw was turned back on the plot rendered the objects correctly.
- Fixed issue of Intel-integrated GPUs failing to repair the drawing area after de-iconifying the application. Additionally, a new configuration file setting, `!Interface ManuallyRepairDamagedDrawArea = TRUE`, can be used if GPUs don't properly repair the drawing area when damaged by dragging other windows over the top of the drawing area. Note that this option does decrease rendering performance and is rarely needed.
- Fixed crash when integrating over I, J, or K Lines within the Integrate dialog.
- Fixed an issue with Tecplot Focus not finding a valid license on Linux machines with FIPS enabled.
- Fixed an issue when the bounding box would not show after running macros.

- Added support for rendering ASCII scatter symbols, missing from the 2025 R2 release. Note that sizing ASCII scatter by variable or coloring the ASCII scatter symbols by RGB/multi-color is currently not enabled. Only uniform sizing and basic colors are honored at this time.

List of Known Issues

- Older Apple Silicon M1 and M2 systems may experience slower performance with very complex scenes that include transparency. M3 and newer systems do not have this performance issue.
- Adjusting line thickness is not supported on macOS systems.
- Rendering of complex scenes with translucency may result in pixelated artifacts. If this is observed, refer to Order Independent Transparency (OIT) settings in the `tecplot.cfg` file and in these Release Notes.
- Node and cell labels in 2D/3D plots do not support text formatting tags including, but not limited to: `<sub>`, `<sup>`, `<greek>`, etc.
- Node and cell labels do not support multi-coloring.
- The scaling of **Plot** → **Advanced 3D Control** → **Lift fractions** is different. Scenes which have adjusted these values may need to be readjusted.
- Linux users running the Wayland compositor with Gnome Window manager may need to install the XWayland server. The `tecfocus` startup script sets the `XDG_SESSION_TYPE` and `QT_QPA_PLATFORM` environment variables requesting x11/xcb compatibility.
- Quad shaped cells, such as with ordered data, rendering contour flooding or contour line style may have a noticeable bend in the contour line going through the cell due to Vulkan only providing triangle primitives for surface rendering. 2025 R1 on the left, 2025 R2 on the right. Notice the bend across the center cell.

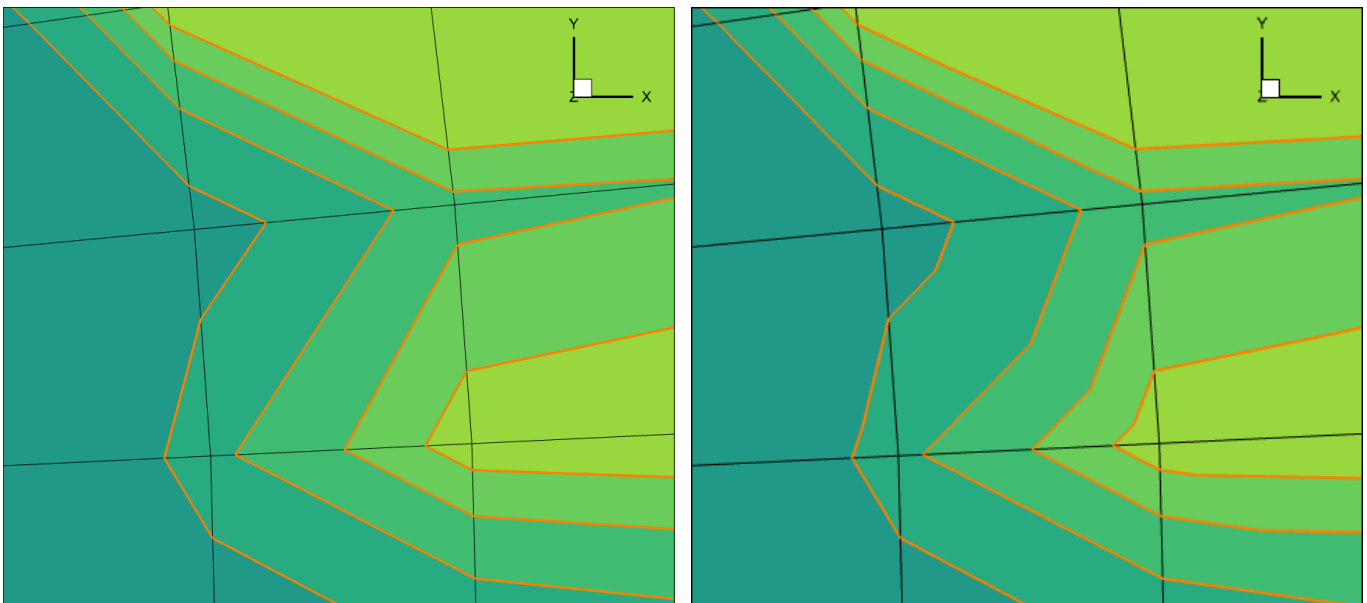

- Scatter symbols beyond a certain size may appear clipped due to graphics card limitations. This can

affect both onscreen and exported images. In the image below, notice the spheres appear clipped as we zoom in. This does not affect Cube or Octahedron symbol shapes.

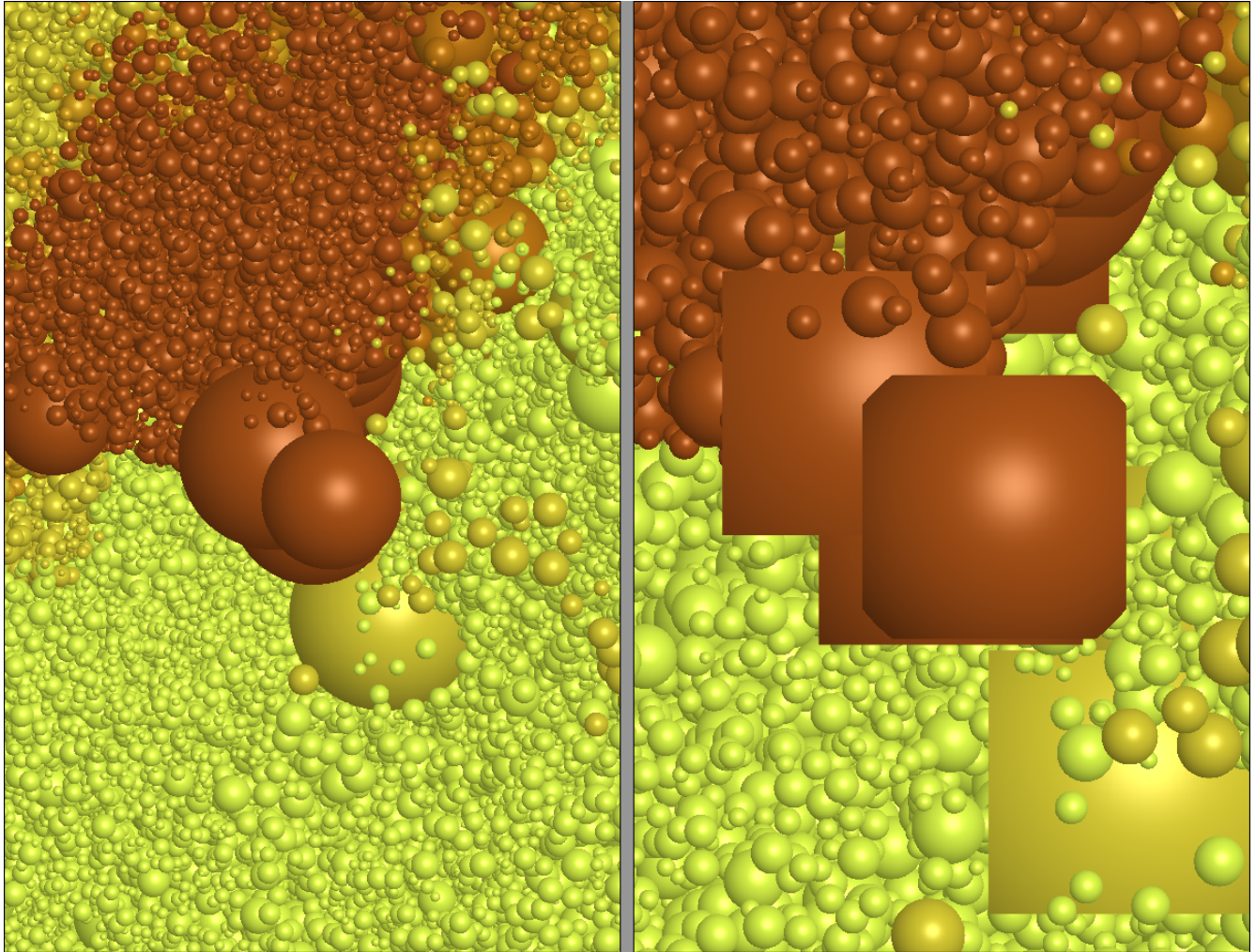

This issue can be resolved for Spheres by updating the `tecplot.cfg` file to use: `GlobalScatter SphereScatterRenderQuality = HIGH`

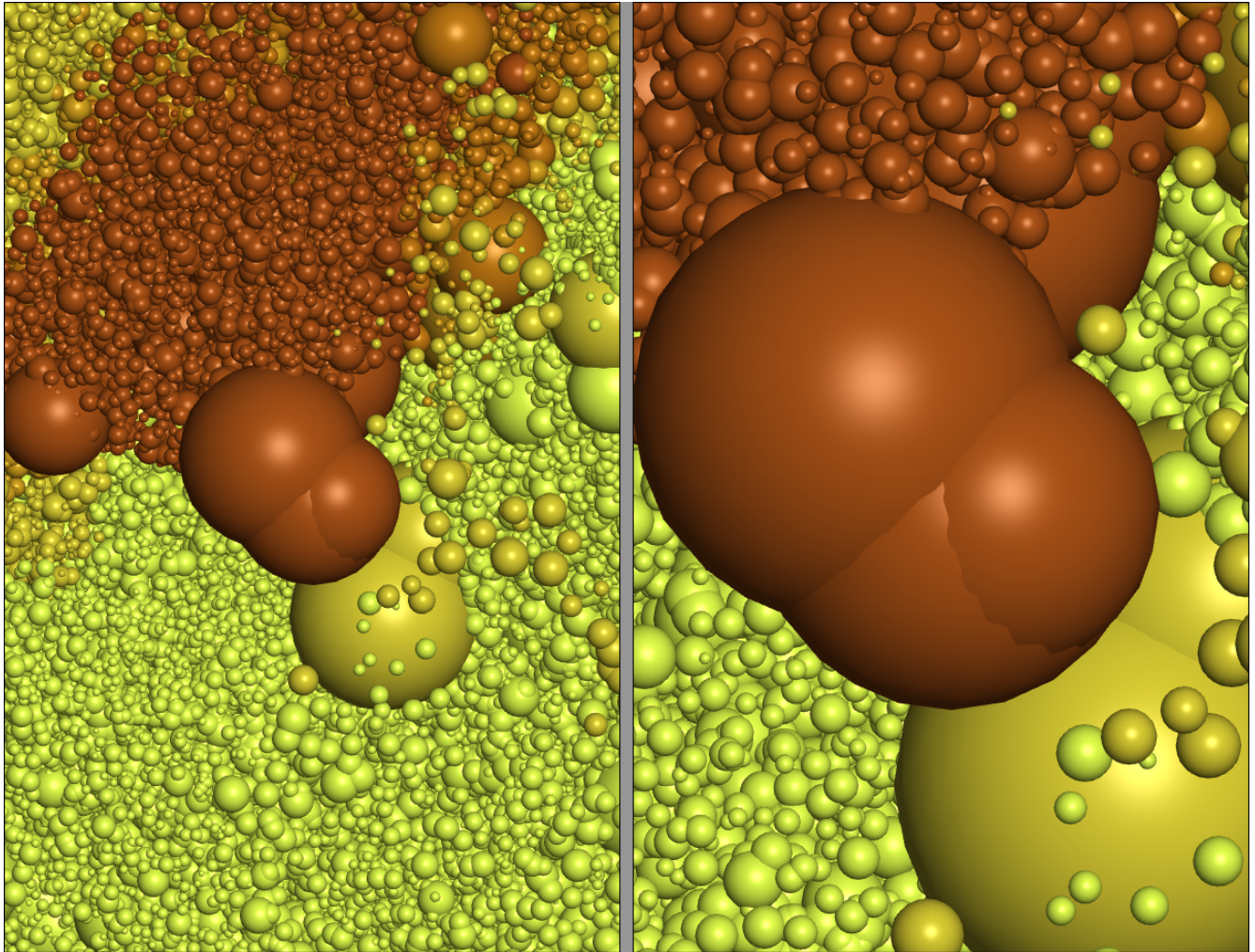

Platform Support

Tecplot Focus is built, tested, and fully supported only on the following operating systems and platforms. The software may also run on operating systems similar to the ones listed here, especially later releases of the same platforms, but our ability to provide support for such installations may be limited.

Windows

- Windows 11

macOS

- 14.0 (Sonoma), 15.0 (Sequoia), 26.0 (Tahoe)
 - Only macOS machines with Apple Silicon processors are supported.

Linux

- Red Hat Enterprise Linux 8, 9
- Rocky Linux 8, 9
- Ubuntu 22.04 LTS, 24.04 LTS

- SUSE Linux Enterprise Desktop (SLED) 15

Platform End of Life Updates

- Windows 10 support ended October 14th, 2025. Tecplot software released after this date will not be supported on Windows 10.
- Intel-based macOS is no longer supported.
- CentOS 7 is no longer supported.
- Red Hat Enterprise Linux 7 is no longer supported.

Platform-Specific Notes

This section details potential issues specific to your operating system.

Windows

Your account must have administrator rights on your computer to install Tecplot Focus, or else right-click the installer and choose "Run as Administrator."

Linux

Temporary Directory

Tecplot Focus relies on being able to create temporary files in the system temporary directory. On Linux, this directory is typically `/usr/tmp` or `/var/tmp`. If your user account does not have permission to write into the system temporary directory, you can use a different directory either by setting the `TMPDIR` environment variable in your profile or by setting the `TEMPFILEPATH` in the `tecplot.cfg` file.

Menu Shortcuts

Menu shortcut keys may not work if the Num Lock is on. You may set the Num Lock to turn off automatically at boot in your computer's BIOS.

SELinux

SELinux (provided with some Linux distributions) adds an extra layer of security. It can prevent Tecplot Focus from starting in some cases.

If you see this error message:

```
mprotect failed in ExecutableAllocator::makeExecutable: Permission denied
```

Enter these two commands:

```
ausearch -c 'tecfocus-bin' --raw | audit2allow -M my-tecfocusbin
```

```
semodule -X 300 -i my-tecfocusbin.pp
```

The information above is provided as a suggestion by the SELinux sealert utility. With it, you can run Tecplot Focus without disabling SELinux.

Mac

Keyboard Shortcuts

Previous versions of Tecplot Focus used the Control key for most keyboard shortcuts, rather than the Mac standard Command key. Tecplot Focus changes these shortcuts to use the Command key under Mac. Similarly, when rotating a 3D plot, you now hold down the Command key while dragging with the right mouse button.

Note that the Alt key may be called Option on some Mac keyboards.

Right Mouse Button

If your Mac's mouse has only a single button, hold the Control key while clicking to access right-click functionality.

Middle Mouse Button

There is no functionality in Tecplot Focus that *requires* a middle mouse button; however, it does provide some shortcuts. Users of single-button mice cannot emulate the middle button, but users of mice with two buttons can hold down Control while right-clicking if their mouse does not support a true middle-button click.

Enjoy Tecplot Focus 2025 R2 and master the view.

Additional Resources

In addition to these Release Notes and HTML Help, Tecplot Focus includes access to these manuals to help you explore all of Tecplot Focus's functionality.

User's Manual

This manual provides a complete description of working with Tecplot Focus features.

Scripting Guide

This guide provides macro command syntax and information on working with macro files and commands.

Quick Reference Guide

This guide provides syntax for zone header files, macro variables, keyboard shortcuts, and more.

Data Format Guide

This guide provides information on outputting simulator data to Tecplot file format.

Installation Guide

These instructions give a detailed description of how to install Tecplot Focus on your machine.

My Tecplot

My Tecplot is Tecplot's one-stop portal that allows you to download software, manage your license keys, and more. Visit it at [My Tecplot](#).

Usage Data Collection

To help us better understand how our customers use our products and improve them further, Tecplot Focus includes an analytics feature that reports user activity over the Internet using the Google Analytics™ platform. This feature tells us which dialogs you use and which controls you manipulate in them. However, to protect your privacy and trade secrets, we do not see names associated with your data (such as variable, zone, or file names) or the actual values of fields in dialogs, nor do we receive any information about you or your organization's identity.

If you do not wish to participate in this program, turn off "Collect Anonymous Usage Data" in the Help menu.

We receive basic information about your operating system, product version, and license at each launch of Tecplot Focus, even if you have opted out of the usage data program. This information is not tied to any usage data collected.

No usage data of any kind is collected if you do not have access to the Internet or if the Google Analytics service is blocked by a firewall.

Crash Reporting

Please help us make Tecplot Focus better by sending a crash report to us in the event that the application terminates unexpectedly.

On Windows, Tecplot Focus creates a crash dump file. You will receive a message indicating that a crash dump file has been created. Click **Yes** in this dialog to open the folder where the file is created. You can then e-mail the most recent `.dmp` file in this folder, along with a description of what you were trying to do, to support@tecplot.com.

On other platforms, no crash dump file is created. However, we urge you to send us a report anyway with as much detail as you can remember.

If you have a moment and a desire to be extra helpful, please re-open Tecplot Focus and choose **Enable Diagnostic Logging** in the **Help** menu. Then redo the steps you took to cause the crash. Tecplot Focus will record your actions as a macro file. If you are able to reproduce the crash, send the resulting `.mcr` file to us (along with the `.dmp` file if you use Windows). On non-Windows platforms, you can find the `.mcr` file in `/usr/tmp/tecplot_${USER}/tpa_diagnostics`.

Crash dumps and diagnostic macros are stored in a temporary folder and will be eventually be deleted by the system. There is no need to delete them manually.

Graphics Drivers

For best results, please make sure that you are using the latest graphics drivers compatible with your hardware and operating system. These can be obtained from your graphics adapter vendor's Web site. Old versions may have issues with Tecplot Focus, especially with larger data sets.

- NVIDIA: www.nvidia.com/Download/index.aspx
- ATI: www.amd.com/en/support
- Intel: www.intel.com/content/www/us/en/download-center/home.html

Copyright

Tecplot Focus Release Notes is for use with Tecplot Focus 2025 R2.

Copyright © 1988-2026 Tecplot, Inc. All rights reserved worldwide. Except for personal use, this manual may not be reproduced, transmitted, transcribed, stored in a retrieval system, or translated in any form, in whole or in part, without the express written permission of Tecplot, Inc., 3535 Factoria Blvd, Ste. 550; Bellevue, WA 98006 U.S.A.

The software discussed in this documentation and the documentation itself are furnished under license for utilization and duplication only according to the license terms. The copyright for the software is held by Tecplot, Inc. Documentation is provided for information only. It is subject to change without notice. It should not be interpreted as a commitment by Tecplot, Inc. Tecplot, Inc. assumes no liability or responsibility for documentation errors or inaccuracies.

Tecplot, Inc.
Post Office Box 52708
Bellevue, WA 98015-2708 U.S.A.
Tel: 1.800.763.7005 (within the U.S. or Canada), 00 1 (425) 653-1200 (internationally)
E-mail: sales@tecplot.com, support@tecplot.com
Questions, comments or concerns regarding this document: support@tecplot.com
For more information, visit www.tecplot.com

Tecplot®, Tecplot 360™, Tecplot 360 EX™, Tecplot Focus, the Tecplot product logos, Preplot™, Enjoy the View™, Master the View™, SZL™, Sizzle™ and Framer™ are registered trademarks or trademarks of Tecplot, Inc. in the United States and other countries. All other product names mentioned herein are trademarks or registered trademarks of their respective owners.

NOTICE TO U.S. GOVERNMENT END-USERS

Use, duplication, or disclosure by the U.S. Government is subject to restrictions as set forth in subparagraphs (a) through (d) of the Commercial Computer-Restricted Rights clause at FAR 52.227-19 when applicable, or in subparagraph (c)(1)(ii) of the Rights in Technical Data and Computer Software clause at DFARS 252.227-7013, and/or in similar or successor clauses in the DOD or NASA FAR Supplement. Contractor/manufacturer is Tecplot, Inc., 3535 Factoria Blvd, Ste. 550; Bellevue, WA 98006 U.S.A.

Part Number: 23-360-07-2 Build Revision 85407

Released: 2/2026

For third-party trademark and copyright information, see the [User's Manual](#).