

# Anna Module Specifications



## DESCRIPTION

Anna™ is the newest introduction to EAW's flagship line of Adaptive™ Systems, providing all the benefits of Adaptive performance in a high-output mid-sized enclosure. Weighing just 135 lbs. (61 kg), the extraordinary output-to-weight ratio makes Anna exceptionally versatile, with applications ranging from small clubs and houses of worship to large arenas and touring productions. Anna's 100° horizontal dispersion further extends the capabilities of Adaptive Systems; columns of Anna can be flown as mains or mixed with columns of Anya™ within the same array to for even greater coverage possibilities. Like all Adaptive Systems, Anna is controlled via Resolution™ 2 software over the Dante™ network and utilizes the same standardized power and data infrastructure.

Anna modules hang straight, without any vertical splay, and Resolution™ 2 software adapts total system performance to produce custom-tailored coverage that delivers coherent, full-frequency range response across the entire coverage area as defined by the user. It is extremely powerful and immensely scalable, making it suitable for anything from small clubs and theaters, to larger houses of worship and arenas. By carefully crafting the size and spacing of the transducers, Anna is able to create radical coverage patterns (i.e., narrowly focused and directed almost straight down) while providing outstanding fidelity within the coverage area and broadband rejection everywhere else.

## FEATURES

- Adaptive Performance™ manages coverage and directivity via Resolution™ 2 software
- Vastly simplified setup process as compared to typical mid-format arrays; uses no vertical splay angles to achieve desired coverage
- On-board diagnostics and Adaptive Healing continuously monitor and correct performance in real time
- High-power, full-bandwidth; scalable to all performance types and venue sizes
- All amplification and processing on-board
- Extremely high output to size & weight ratio, size and output capabilities allows it to be used in a wide variety of venues

## APPLICATIONS

- Portable and touring sound reinforcement of any scale (from theaters and concert halls to larger arenas)
- Installed sound reinforcement for venues of all sizes (from clubs and performing arts venues to larger houses of worship and multipurpose halls)

Each Anna module includes 8x 1-in exit / 35mm voice coil HF compression drivers loaded on a proprietary HF horn that expands to fill nearly the entire face of the enclosure. 4x 5-in MF cone transducers, arranged in two columns of two, use Radial Phase Plugs™ and Concentric Summation Array™ technology to enter the horn and sum coherently with the HF wave front. Dual high-power 10-in LF cone transducers use Offset Aperture™ loading to increase the spacing of the apparent acoustical centers, extending effective horizontal pattern control well into the LF range.

The module's horizontal symmetry ensures coherent summation without anomalies through the crossover regions that result from physically offset acoustic sources. This provides consistent, HF dispersion and broadband pattern control in the horizontal plane.

Each Anna module includes a field-replaceable Power Plant with 14 channels of digital signal processing and amplification to drive each of the module's 14 transducers independently, with all parameters determined by Resolution™ software to provide optimal coverage based to every listening position.

# Anna Module Specifications



## 3-WAY FULL-RANGE Array module

See NOTES TABULAR DATA for details

### Configuration

Subsystem	Transducer	Loading
	LF 2x 10-in cone, 3 in voice coil	Vented, Phase Aligned™, Offset Aperture™ loading
	MF 4x 5-in cone, 38mm voice coil	Horn-loaded w/ Radial Phase Plug™ and CSA™ apertures
	HF 8x1-in exit, 35mm voice coil	Horn-loaded compression driver

### Operating Mode

Amplifier Channels	Signal Processing
2x LF	DSP w/ EAW Focusing™ and Adaptive Performance™
4x MF	DSP w/ EAW Focusing™ and Adaptive Performance™
8x HF	DSP w/ EAW Focusing™ and Adaptive Performance™

### Performance

Operating Range	45 Hz to 18 kHz
Nominal Beamwidth	Horz 100° (for single column; scalable up to 360° utilizing multiple columns)
	Vert Adaptive

#### Calculated Axial Output Limit (whole space SPL - 6dB Crest Factor) Unadapted

	Average	Peak
LF	124 dB	130 dB
MF	130 dB	136 dB
HF	135 dB	141 dB

#### Calculated Axial Output Limit (whole space SPL - 6dB Crest Factor) Adapted for 45° Vertical Pattern

	Average	Peak
LF	124 dB	130 dB
MF	130 dB	136 dB
HF	132 dB	138 dB

#### Calculated Axial Output Limit (whole space SPL - 6dB Crest Factor) Adapted for 90° Vertical Pattern

	Average	Peak
LF	124 dB	130 dB
MF	130 dB	136 dB
HF	129 dB	135 dB

**Max SPL** (whole space SPL 12dB Crest Factor) 147 dB

Real-world SPL capabilities in audience planes will vary with enclosure quantity and system adaptation for a given audience area.

# Anna Module Specifications

## Electrical Performance

<b>Input</b>	
Type	Electronically Balanced
Max Input Level	25 dBu
Impedance	20 kOhm (balanced)
Wiring	XLR/F, Pin 1 chassis, pin 2 +, pin 3 – Separate loop-thru XLRM (for analog signal only)
<b>Input Selection</b>	Analog, AES (Ch 1/2), Dante

<b>Amplifiers &amp; Processing</b>	<b>LF</b>	<b>MF</b>	<b>HF</b>
Type	Class D	Class D	Class D
Maximum Output	2 x 1000W	4 x 500W	8 x 500W
Driver Protection	Integral DSP limiting	Integral DSP limiting	Integral DSP limiting

<b>AC Mains (Nominal)</b>	
Connector	Neutrik® powerCON™ TRUE1™
Input	100 V to 240 V
Frequency	50 Hz to 60 Hz
Power Consumption	Idle 120 W Peak Draw 1,600 W

## Control/Communications

Connections	USB A & B, 2x Neutrik® etherCON™
Protocols	USB, Ethernet/Dante
Software	Resolution™ 2 (available at eaw.com)
Indicators	Test, Function, Input (Network, Analog, AES/EBU), Network Status
User Controls	Test, Function

## Ordering Data

Description	Part Number
G24 System (24 modules) 115V	2046437
G24 System (24 modules) 230V	2046438
G12 System (12 modules) 115V	2046435
G12 System (12 modules) 230V	2046436
Distro Rack (supports 12 modules) 115V	2041779
Distro Rack (supports 12 modules) 230V	2042545
Distro Flybar	2042596
Distro Pallet	2042482
Flybar	2046533
Cable Power Loom (6 modules)	2045005
Cable Power Extender (6 modules)	2045006
Cable Network Loom Short (6 modules)	2045007
Cable Network Loom Long (6 modules)	2045008
Cable Network Extender (6 modules)	2045009
Caster Pallet (4 modules)	2046532
Cover (4 modules)	2046446
Spare LF Transducer Pack (1 Driver)	2046449
Spare MF Transducer Pack (1 Driver)	2046495
Spare HF Transducer Pack (8 Drivers)	2046481
Spare Amplifier Service Pack	2046448

# Anna Module Specifications

## Enclosure

**Material** Powder-coated cast aluminum; Exterior-grade Baltic birch plywood with wear-resistant textured RoadCoat™

**Grille** Powder-coated perforated steel

**NOTE:** This drawing has been reduced. Do not scale.

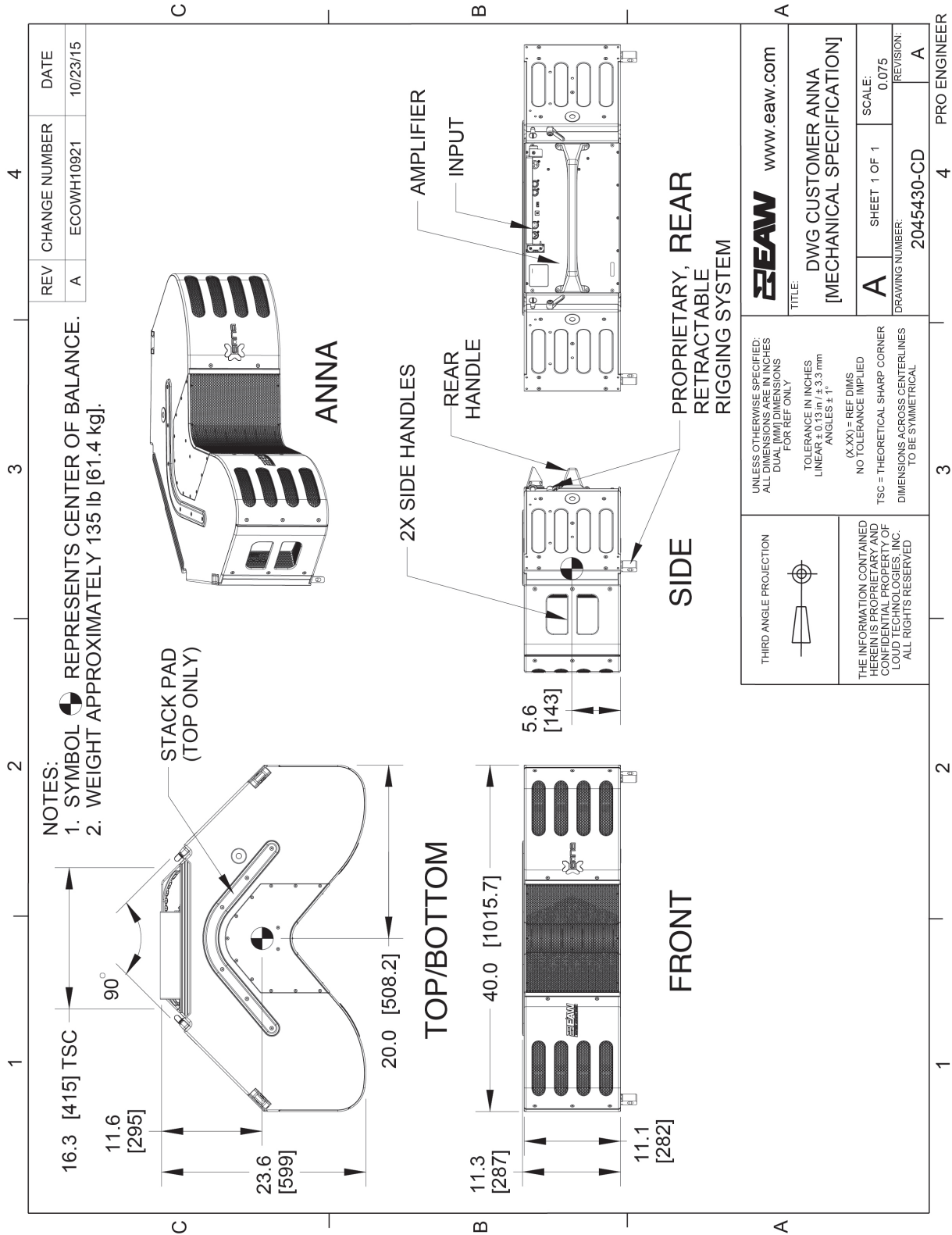

# Anna Module Specifications

## Performance Data, Unadapted

See NOTES GRAPHIC DATA for details

### Frequency Response: Processed - Multi Amp

LF = green, MF = orange, HF = black, Complete = blue

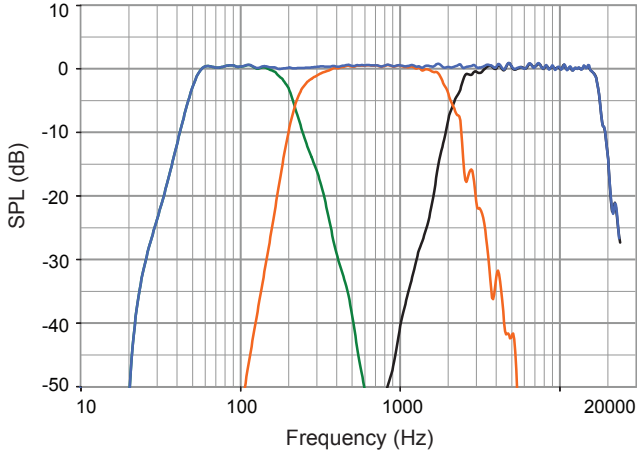

### Beamwidth

Horizontal = orange, Vertical = black

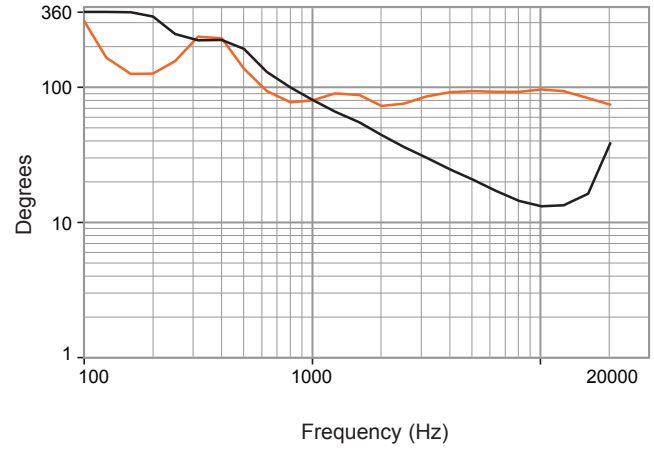

### Phase Linearity

Complete = blue

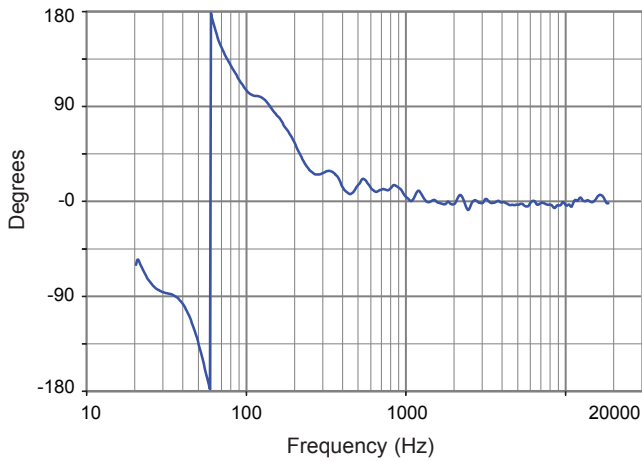

# Anna Module Specifications

## Horizontal Polar Data, Unadapted

See NOTES GRAPHIC DATA for details

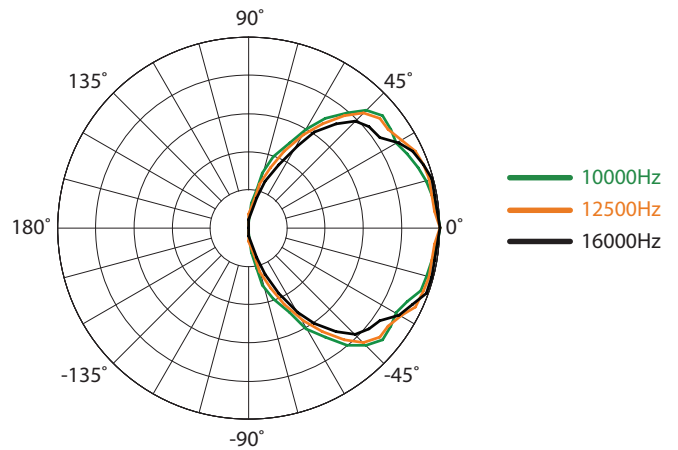
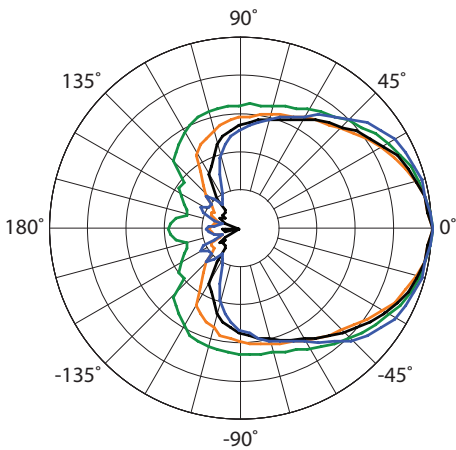
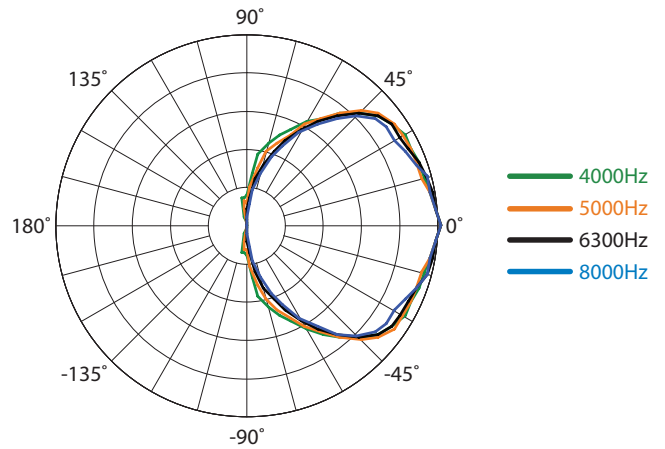
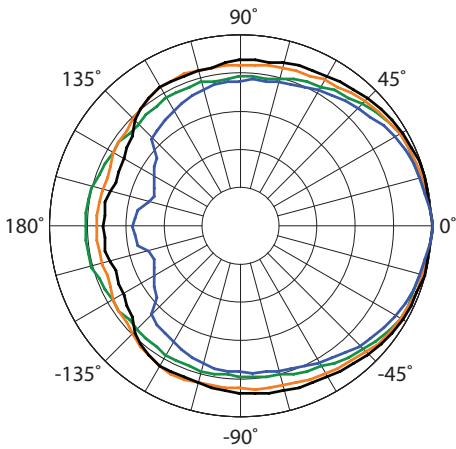
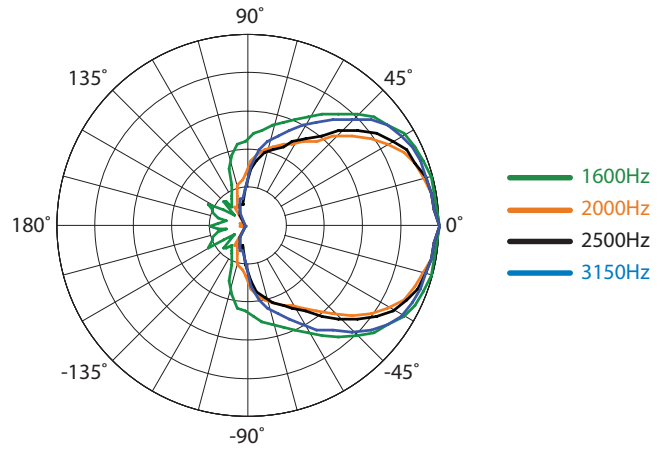
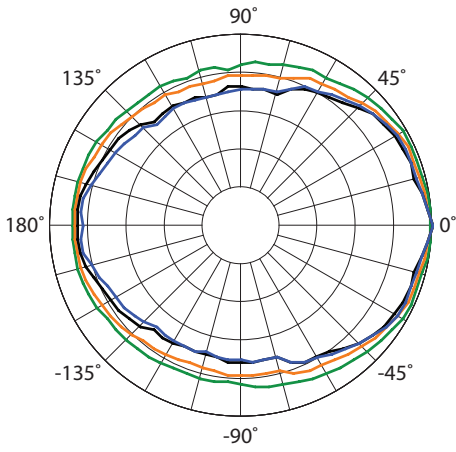

# Anna Module Specifications

## Vertical Polar Data, Unadapted

See NOTES GRAPHIC DATA for details

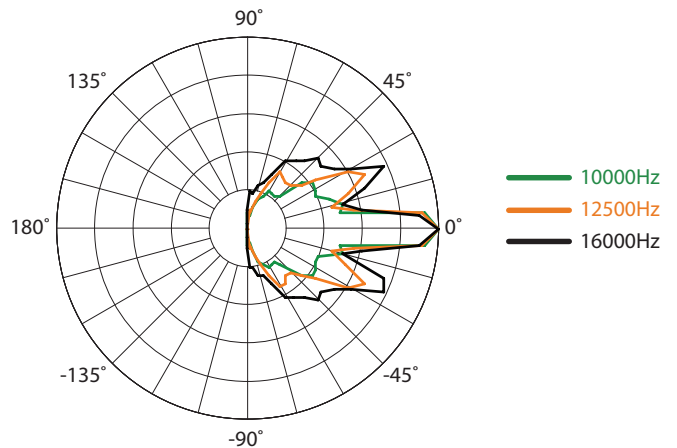
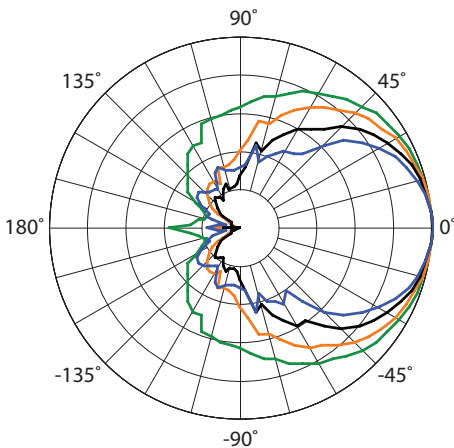
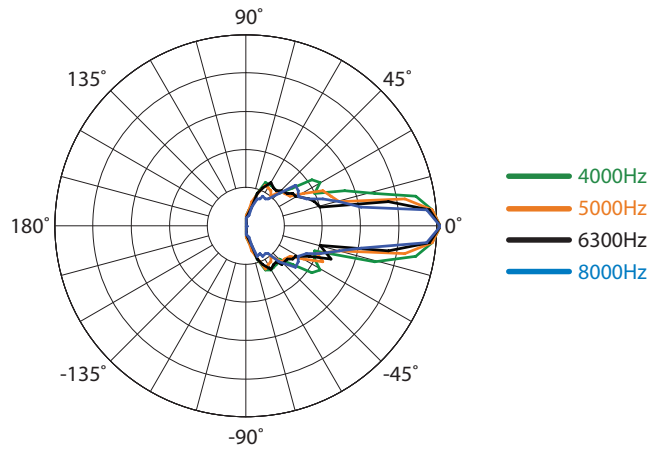
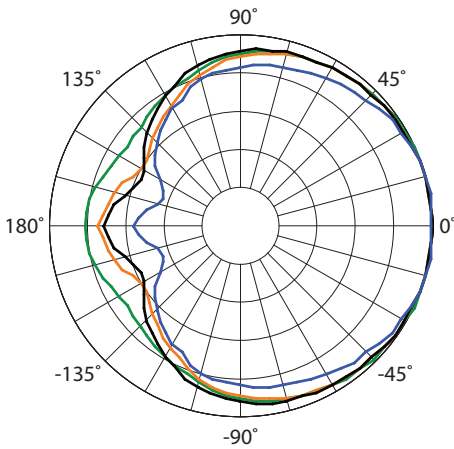
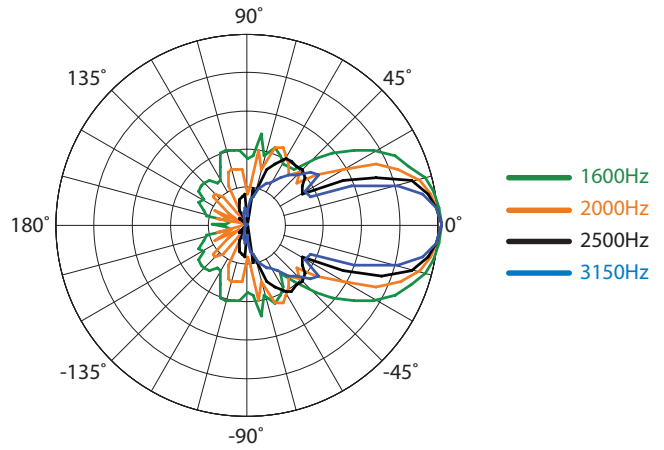
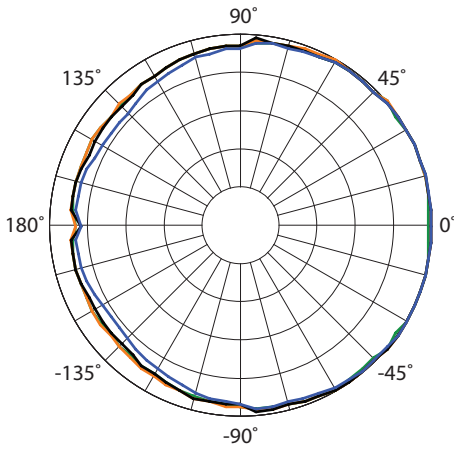

# Anna Module Specifications

## Vertical Polar Data, Adapted for 45° Vertical Pattern

See NOTES GRAPHIC DATA for details

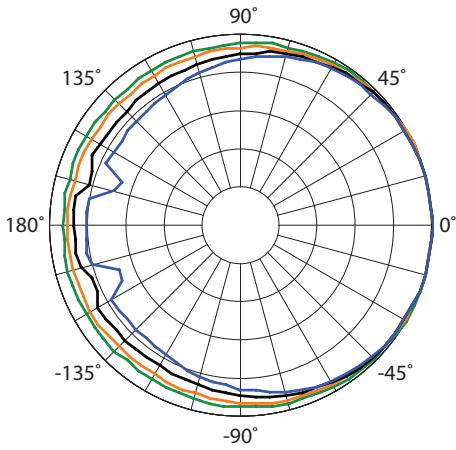

- 100Hz
- 125Hz
- 160Hz
- 200Hz

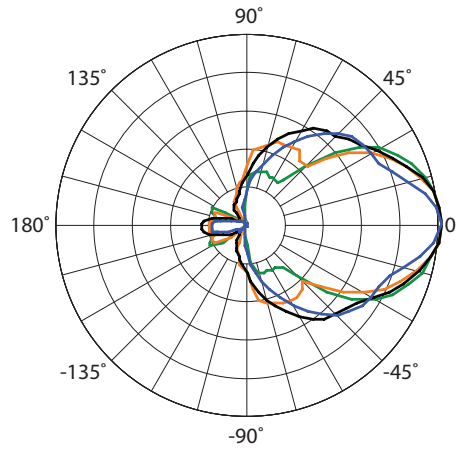

- 1600Hz
- 2000Hz
- 2500Hz
- 3150Hz

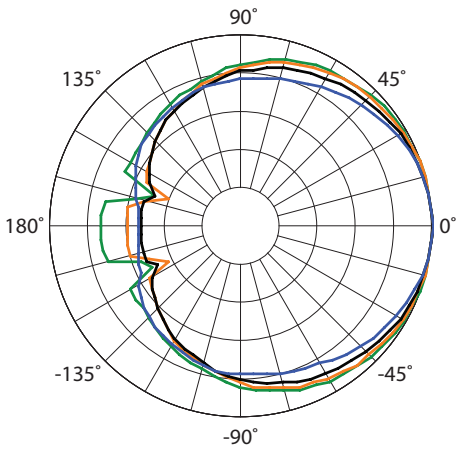

- 250Hz
- 315Hz
- 400Hz
- 500Hz

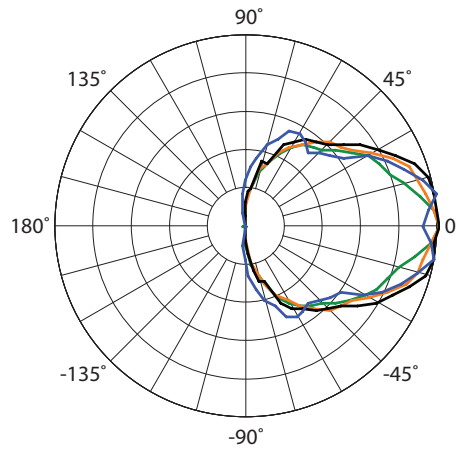

- 4000Hz
- 5000Hz
- 6300Hz
- 8000Hz

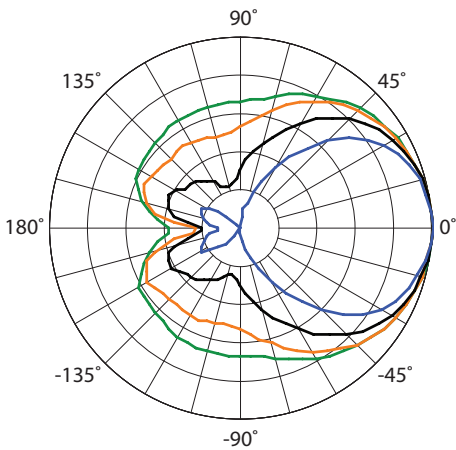

- 630Hz
- 800Hz
- 1000Hz
- 1250Hz

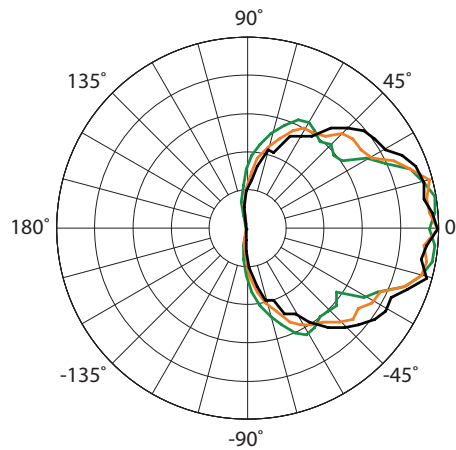

- 10000Hz
- 12500Hz
- 16000Hz

# Anna Module Specifications

## Vertical Polar Data, Adapted for 90° Vertical Pattern

See NOTES GRAPHIC DATA for details

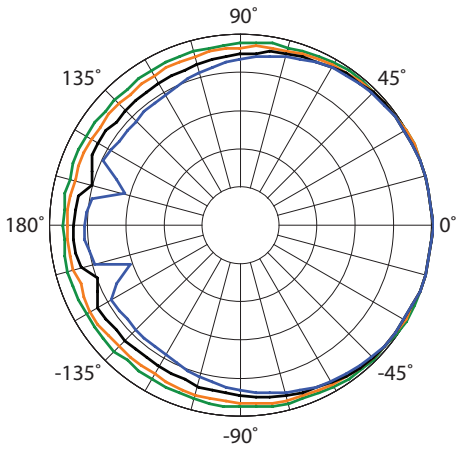

- 100Hz
- 125Hz
- 160Hz
- 200Hz

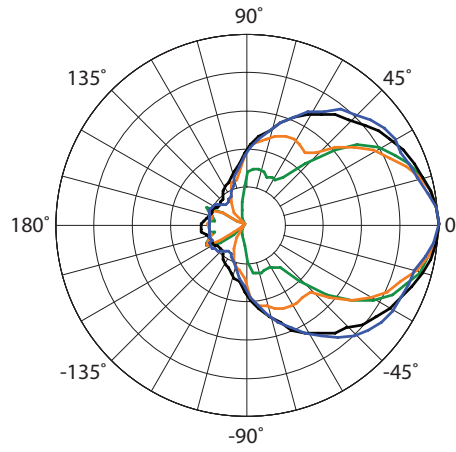

- 1600Hz
- 2000Hz
- 2500Hz
- 3150Hz

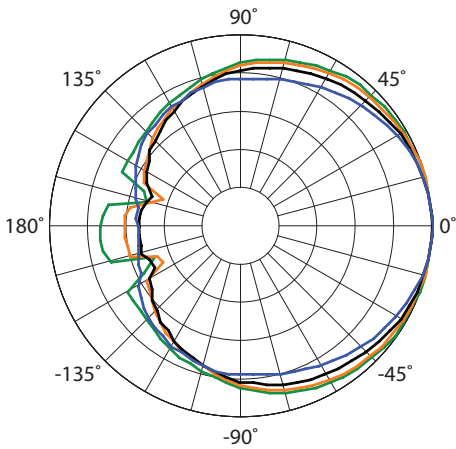

- 250Hz
- 315Hz
- 400Hz
- 500Hz

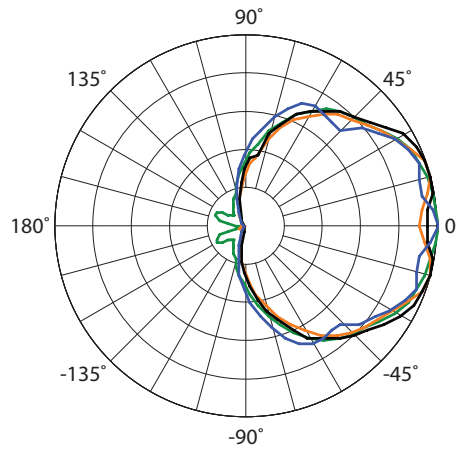

- 4000Hz
- 5000Hz
- 6300Hz
- 8000Hz

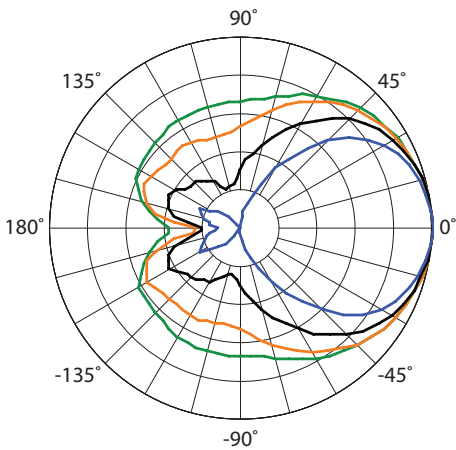

- 630Hz
- 800Hz
- 1000Hz
- 1250Hz

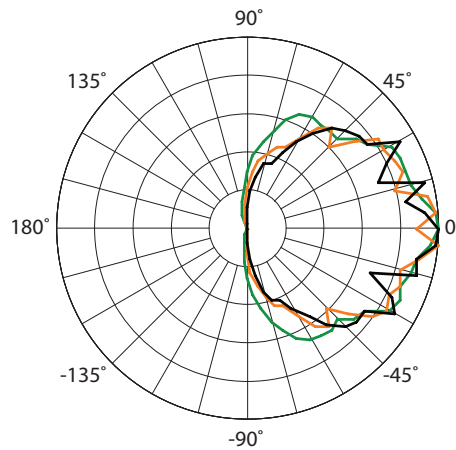

- 10000Hz
- 12500Hz
- 16000Hz

# Anna Module Specifications

## Input Panel



1. powerCON™ TRUE1™ AC Mains Input
2. USB Port Type B
3. USB Port Type A
4. Dual etherCON™ Connectors (redundant)
5. XLR Audio Input Connector
6. XLR Audio Loop-Through Connector
7. Network Activity Indicator
8. Device Test Key and Light
9. Input Type Indicator
10. Function Key and Light

## Signal Diagram

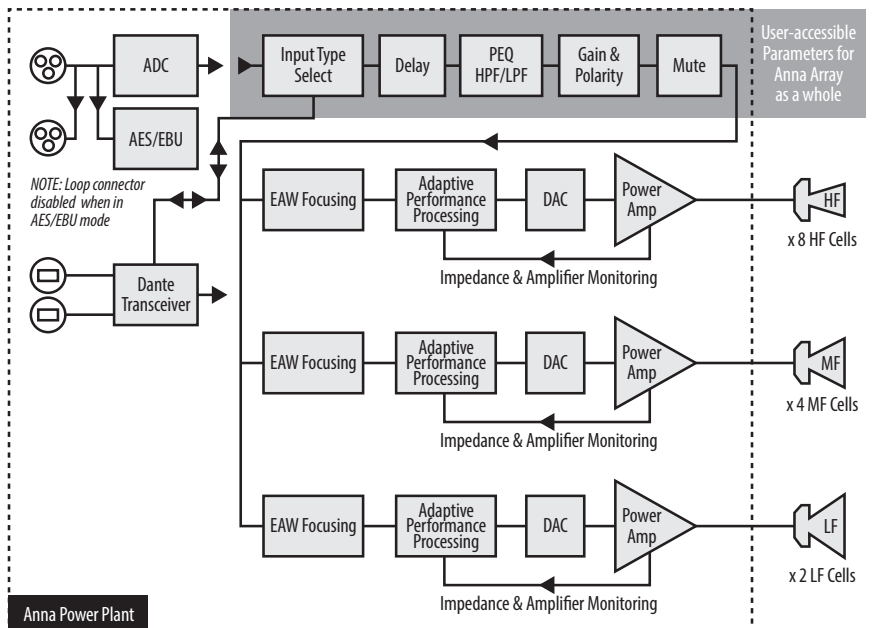

## Legend

- HPF** High Pass Filter for crossover –or– Recommended High Pass Filter
- LPF** Low Pass Filter for crossover
- LF/MF/HF** Low Frequency / Mid Frequency / High Frequency
- AMP** User Supplied Power Amplifier –or– Integral Amplifier for NT products
- XVR** Passive LPFs, HPFs, and EQ integral to the loudspeaker
- EAW Focusing** Digital Signal Processor capable of implementing EAW Focusing

## Notes

### TABULAR DATA

- Measurement/Data Processing Systems:** Primary – FChart; proprietary EAW software; Secondary – Brüel & Kjær 2012.
- Microphone Systems:** Earthworks M30; Brüel & Kjær 4133
- Measurements:** Dual channel FFT; length: 32 768 samples; sample rate: 48 kHz; logarithmic sine wave sweep.
- Measurement System Qualification** (includes all uncertainties): SPL: accuracy +/-0.2 dB @ 1 kHz, precision +/-0.5 dB 20 Hz to 20 kHz, resolution 0.05 dB; Frequency: accuracy +/-1 %, precision +/-0.1 Hz, resolution the larger of 1.5 Hz or 1/48 octave; Time: accuracy +/-10.4 µs, precision +/-0.5 µs, resolution 10.4 µs; Angular: accuracy +/-1°, precision +/-0.5°, resolution 0.5°.
- Environment:** Measurements time-windowed and processed to eliminate room effects, approximating an anechoic environment. Data processed as anechoic or fractional space, as noted.
- Measurement Distance:** 7.46 m. Acoustic responses represent complex summation of the subsystems at 20 m. SPL is referenced to other distances using the Inverse Square Law.
- Enclosure Orientation:** For beamwidth and polar specifications, as shown in Mechanical Specification drawing.
- Volts:** Measured rms value of the test signal.
- Watts:** Per audio industry practice, "loudspeaker watts" are calculated as voltage squared divided by rated nominal impedance. Thus, these are not True Watt units of energy as defined by International Standard.
- SPL:** (Sound Pressure Level) Equivalent to the average level of a signal referenced to 0 dB SPL = 20 microPascals.
- Subsystem:** This lists the transducer(s) and their acoustic loading for each passband. Sub = Subwoofer, LF = Low Frequency, MF = Mid Frequency, HF = High Frequency.
- Operating Mode:** User selectable configurations. Between system elements, a comma (,) = separate amplifier channels; a slash (/) = single amplifier channel. DSP = Digital Signal Processor.  
IMPORTANT: To achieve the specified performance, the listed external signal processing must be used with EAW-provided settings.
- Operating Range:** Range where the processed Frequency Response stays within -10 dB SPL of the power averaged SPL within this range; measured on the geometric axis. Narrow band dips are excepted.
- Nominal Beamwidth:** Design angle for the -6 dB SPL points, referenced to 0 dB SPL as the highest level.
- Axial Sensitivity:** Power averaged SPL over the Operating Range with an input voltage that would produce 1 W at the nominal impedance; measured with no external processing on the geometric axis, referenced to 1 m.
- Nominal Impedance:** Selected 4, 8, or 16 ohm resistance such that the minimum impedance point is no more than 20% below this resistance over the Operating Range.
- Accelerated Life Test:** Maximum test input voltage applied with an EIA-426B defined spectrum; measured with recommended signal processing and Recommended Protection Filter.
- Calculated Axial Output Limit:** Highest average and peak SPLs possible during the Accelerated Life Test. The Peak SPL represents the 2:1 (6 dB) crest factor of the Life Test signal.
- High Pass Filter:** This helps protect the loudspeaker from excessive input signal levels at frequencies below the Operating Range.

### GRAPHIC DATA

- Resolution:** To remove insignificant fine details, 1/12 octave cepstral smoothing was applied to acoustic frequency responses and 1/3 octave cepstral smoothing was applied to the beamwidth and impedance data. Other graphs are plotted using raw data.
- Frequency Responses:** Variation in acoustic output level with frequency for a constant input signal. Processed: normalized to 0 dB SPL. Unprocessed inputs: 2 V (4 ohm nominal impedance), 2.83 V (8 ohm nominal impedance), or 4 V (16 ohm nominal impedance) referenced to a distance of 1 m.
- Processor Response:** The variation in output level with frequency for a constant input signal of 0.775 V = 0 dB reference.
- Beamwidth:** Average angle for each 1/3 octave frequency band where, starting from the rear of the loudspeaker, the output first reaches -6 dB SPL referenced to 0 dB SPL as the highest level. This method means the output may drop below -6 dB SPL within the beamwidth angle.
- Impedance:** Variation in impedance magnitude, in ohms, with frequency without regard to voltage/current phase. This means the impedance values may not be used to calculate True Watts (see 9 above).
- Polar Data:** Horizontal and vertical polar responses for each 1/3 octave frequency band 100 Hz to 16 kHz or Operating Range.