

ENGINEERING STATICS

Open and Interactive

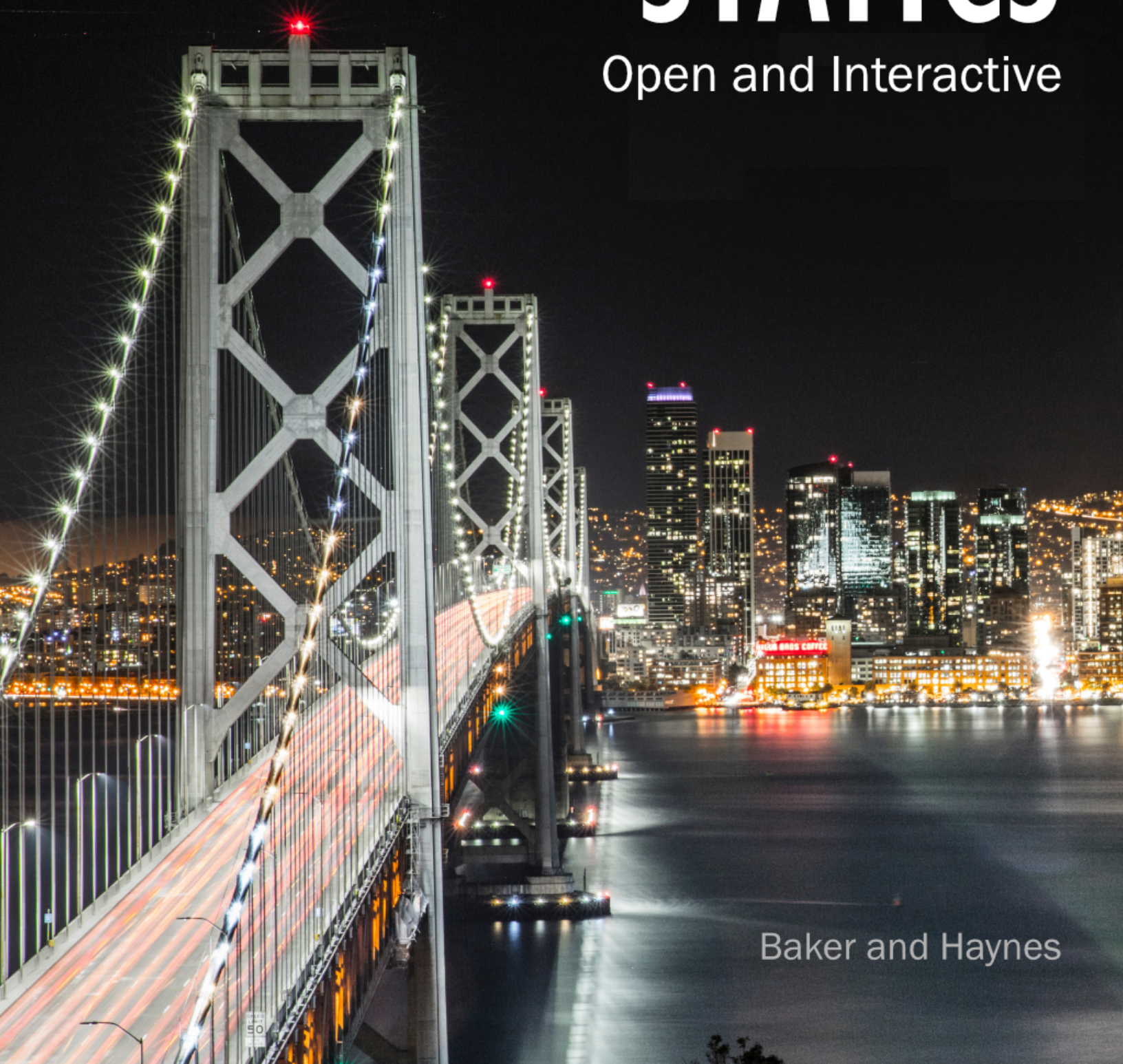

Baker and Haynes

Engineering Statics

Open and Interactive

Engineering Statics

Open and Interactive

Daniel W. Baker
Colorado State University

William Haynes
Massachusetts Maritime Academy

July 1, 2026

Website: <https://engineeringstatics.org>

About this Book

Engineering Statics: Open and Interactive is a free, open-source textbook for anyone who wishes to learn more about vectors, forces, moments, static equilibrium, and the properties of shapes. Specifically, it is appropriate as a textbook for Engineering Mechanics: Statics, the first course in the Engineering Mechanics series offered in most university-level engineering programs.

This book's content should prepare you for subsequent classes covering Engineering Mechanics: Dynamics and Mechanics of Materials. At its core, *Engineering Statics* provides the tools to solve static equilibrium problems for rigid bodies. The additional topics of resolving internal loads in rigid bodies and computing area moments of inertia are also included as stepping stones for later courses. We have endeavored to write in an approachable style and provide many questions, examples, and interactives for you to engage with and learn from.

Feedback. Feedback and suggestions can be provided directly to the lead author Dan Baker via email at dan.baker@colostate.edu, by clicking the feedback button in the html footer. When reporting errors, please include a bit of the surrounding text to help locate the problem area in the source. The [EngineeringStaticsGoogleGroup](#) is a good place to ask the authors and users questions about the book. Please join the group and say “Hi” if you are using the book for teaching purposes.

Access. The entire book is available for free as an interactive online ebook at <https://engineeringstatics.org>. While the interactive version works best on larger screens, it will also work smartphones but with some limitations due to limited screen width. A non-interactive PDF version, suitable for printing or offline reading on a tablet or computer, is available at <https://engineeringstatics.org/pdf/statics.pdf>. The PDF is searchable and easy to navigate using embedded links.

The source files for this book are available on GitHub at <https://github.com/dantheboatman/EngineeringStatics>.

License. *Engineering Statics: Open and Interactive* is licensed under a Creative Commons Attribution-Non Commercial-Share Alike 4.0 International Li-

cense [BY-NC-SA](#). You are free to download, use, and print this work as you wish as long as your use is not primarily intended for or directed toward commercial advantage or monetary compensation. You can also modify the text as much as you like (for example to create a custom edition for your students), as long as you attribute the parts of the book you use to the authors. Please share your improvements with the authors!

All the GeoGebra content found in the book is licensed under a Creative Commons Attribution-Non Commercial-Share Alike 3.0 International License with more detailed information found at <https://www.geogebra.org/license>

End of Chapter exercises. The randomized end-of-chapter exercises were made using the [Numbas](#) open-source assessment system and [Geogebra](#) for the dynamic diagrams. Exercises in the [EngineeringStaticsRepository](#) can be freely remixed into your own homework sets or online exams using the [NumbasEditor](#). You can also use the editor to write new questions or modify existing ones.

The exercises can be integrated into your institution's Virtual Learning Environment to set deadlines and automatically record grades. See the [NumbasDocumentation](#) for more information. To fully take advantage of all the features, you may need the support of your institution's IT department to install the [NumbasLTProvider](#).

Please ask questions about Numbas integration and share any good problems you write with the Engineering Statics Group.

On the Cover. Photo of the San Francisco–Oakland Bay Bridge and city skyline, taken from Yerba Buena Island by Artur Westergren.

Image source: <https://unsplash.com/photos/Rx92z9dU-mA>

Acknowledgements

This book is the vision of a handful of instructors who wanted to create a free and open Engineering Statics textbook filled with dynamic, interactive diagrams to encourage visualization and engineering intuition.

Dr. Baker brought together a team of volunteers from large public universities, small private colleges, and community colleges across the United States to write the text and create the interactive elements. Some content was adapted with permission from Jacob Moore's *Mechanics Map - Open Textbook Project*. <http://mechanicsmap.psu.edu/>. After two years of development the book was released to the public in 2020.

The book continues to evolve thanks to the contributions, suggestions, and corrections made by users of the text, both professors and students. The original authors are listed below, and others who have contributed are acknowledged in the source code on GitHub.

DANIEL W. BAKER
Colorado State University

JAMES LORD
Virginia Tech

DEVIN BERG
University of Wisconsin - Stout

RANDY MONDRAGON
Colorado State University

ANDY GUYADER
Cal Poly, San Luis Obispo

JACOB MOORE
Penn State University – Mont Alto

WILLIAM HAYNES
Massachusetts Maritime Academy

SCOTT BEVILL
Colorado Mesa University

ERIN HENSLEE
Wake Forest University

ERIC DAVISHAHL
Whatcom Community College

ANNA HOWARD
North Carolina State University

JOEL LANNING
University of California, Irvine

RICHARD PUGSLEY
Tidewater Community College

The book was supported by funding from the Colorado Department of Higher Education, the Colorado State University Digital Learning Initiative, and the Colorado State University Libraries.

Contents

About this Book	iv
Acknowledgements	vi
1 Introduction to Statics	1
1.1 Newton's Laws of Motion	3
1.2 Units	7
1.3 Forces	13
1.4 Problem Solving	15
2 Forces and Other Vectors	18
2.1 Vectors	18
2.2 One-Dimensional Vectors	21
2.3 2D Coordinate Systems & Vectors	22
2.4 3D Coordinate Systems & Vectors	29
2.5 Unit Vectors	41
2.6 Vector Addition	48
2.7 Dot Products	58
2.8 Cross Products	68
2.9 Exercises (Ch. 2)	76
3 Equilibrium of Particles	77
3.1 Equilibrium	77
3.2 Particles	78
3.3 1D Particle Equilibrium	79
3.4 2D Particle Equilibrium	90
3.5 3D Particle Equilibrium	111
3.6 Exercises (Ch. 3)	121

4	Moments and Static Equivalence	122
4.1	Moment of Force	123
4.2	Scalar Addition of Moments	129
4.3	Varignon's Theorem	132
4.4	3D Moments	144
4.5	Couples	157
4.6	Equivalent Transformations	159
4.7	Statically Equivalent Systems	163
4.8	Exercises (Ch. 4)	173
5	Rigid Body Equilibrium	174
5.1	Degree of Freedom	174
5.2	Free-Body Diagrams	175
5.3	Equations of Equilibrium	182
5.4	2D Rigid Body Equilibrium	183
5.5	3D Rigid Body Equilibrium	190
5.6	Stability and Determinacy	194
5.7	Equilibrium Examples	196
5.8	Exercises (Ch. 5)	200
6	Equilibrium of Structures	201
6.1	Structures	201
6.2	Interactions between members	203
6.3	Trusses	205
6.4	Method of Joints	213
6.5	Method of Sections	216
6.6	Frames and Machines	217
6.7	Summary	231
6.8	Exercises (Ch. 6)	234
7	Centroids and Centers of Gravity	235
7.1	Weighted Averages	236
7.2	Center of Gravity	237
7.3	Center of Mass	241
7.4	Centroids	241
7.5	Centroids using Composite Parts	246
7.6	Average Value of a Function	253
7.7	Centroids using Integration	256
7.8	Distributed Loads	283
7.9	Fluid Statics	288
7.10	Exercises (Ch. 7)	297

8	Internal Forces	298
8.1	Internal Forces	298
8.2	Sign Conventions	301
8.3	Internal Forces at a Point	302
8.4	Shear and Bending Moment Diagrams	310
8.5	Relations between Loading, Shear and Moment	311
8.6	Section Cut Method	314
8.7	Graphical Method	319
8.8	Integration Method	325
8.9	Geogebra Interactives	332
8.10	Summary	341
8.11	Exercises (Ch. 8)	344
9	Friction	345
9.1	Dry Friction	346
9.2	Slipping vs. Tipping	352
9.3	Wedges	354
9.4	Screw Threads	358
9.5	Flexible Belts	366
9.6	Journal Bearings	375
9.7	Rotating Discs	378
9.8	Exercises (Ch. 9)	384
10	Moments of Inertia	385
10.1	Integral Properties of Shapes	385
10.2	Moments of Inertia of Common Shapes	394
10.3	Parallel Axis Theorem	412
10.4	Composite Shapes	420
10.5	Polar Moment of Inertia	431
10.6	Radius of Gyration	432
10.7	Products of Inertia	434
10.8	Mass Moment of Inertia	434
10.9	Exercises (Ch. 10)	437
 Appendices		
A	Notation	438
B	Useful Mathematics	440
B.1	Distance Formula	440
B.2	Right Triangle Trigonometry	440

B.3	Oblique Triangle Trigonometry	442
C	Properties of Shapes	444
C.1	Centroids of Common Shapes	444
C.2	Moment of Inertia of Common Shapes	446
D	Properties of Steel Sections	447
D.1	Angles	448
D.2	Channels	450
D.3	Standard Sections	452
D.4	Wide Flange Sections	455

Chapter 1

Introduction to Statics

Engineering Statics is the gateway into *engineering mechanics*, which is the application of Newtonian physics to design and analyze objects, systems, and structures with respect to motion, deformation, and failure. In addition to learning the subject itself, you will also develop skills in the art and practice of problem solving and mathematical modeling, skills that will benefit you throughout your engineering career.

The subject is called “statics” because it is concerned with particles and rigid bodies that are in equilibrium, and these will usually be stationary, i.e. static.

The chapters in this book are:

[Introduction to Statics](#)— an overview of statics and an introduction to units and problem solving.

[Forces and Other Vectors](#)— basic principles and mathematical operations on force and position vectors.

[Equilibrium of Particles](#)— an introduction to equilibrium and problem solving.

[Moments and Static Equivalence](#)— the rotational tendency of forces, and simplification of force systems.

[Rigid Body Equilibrium](#)— balance of forces and moments for single rigid bodies.

[Equilibrium of Structures](#)— balance of forces and moments on interconnected systems of rigid bodies.

[Centroids and Centers of Gravity](#)— an important geometric property of shapes and rigid bodies.

[Internal Forces](#)— forces and moments within beams and other rigid bodies.

[Friction](#)— equilibrium of bodies subject to friction.

Moments of Inertia— an important property of geometric shapes used in many applications.

Your statics course may not cover all of these topics, or may move through them in a different order.

Below are two examples of the types of problems you'll learn to solve in statics. Notice that each can be described with a picture and problem statement, a free-body diagram, and equations of equilibrium.

Equilibrium of a particle: A 140 lb person walks across a slackline stretched between two trees. If angles α and θ are known, find the tension in each end of the slackline.

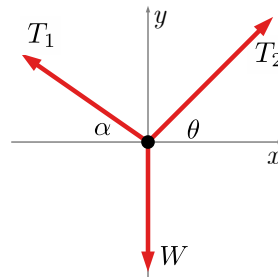

Person's point of contact to slackline:

$$\Sigma F_x = 0$$

$$-T_1 \cos \alpha + T_2 \cos \theta = 0$$

$$\Sigma F_y = 0$$

$$T_1 \sin \alpha + T_2 \sin \theta - W = 0$$

Equilibrium of a rigid body: Given the interaction forces at point C on the upper arm of the excavator, find the internal axial force, shear force, and bending moment at point D .

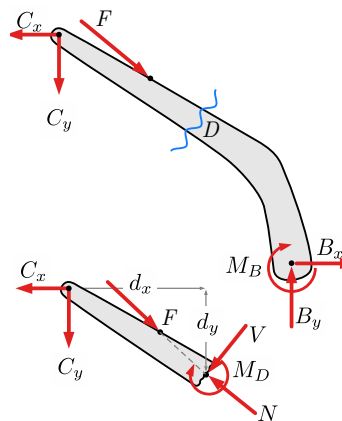

Section cut FBD:

$$\Sigma F_x = 0$$

$$-C_x + F_x - V_x - N_x = 0$$

$$\Sigma F_y = 0$$

$$-C_y - F_y - V_y + N_y = 0$$

$$\Sigma M_D = 0$$

$$+(d_y)C_x + (d_x)C_y - M_D = 0$$

The knowledge and skills gained in Statics will be used in your other engineering courses, in particular in Dynamics, Mechanics of Solids (also called Strength or Mechanics of Materials), and in Fluid Mechanics. Statics will be a foundation of your engineering career.

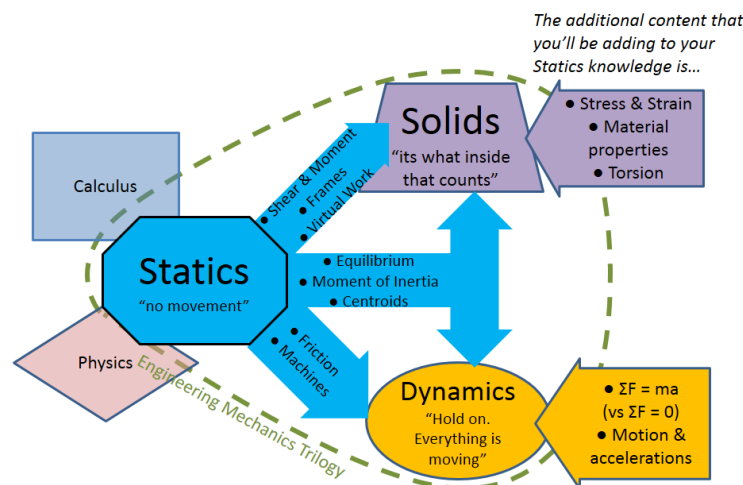

Figure 1.0.1 Map of how Statics builds upon the prerequisites of Calculus and Physics and then informs the later courses of Mechanics of Solids and Dynamics.

1.1 Newton's Laws of Motion

Key Questions

- What are the two types of motion?
- What three relationships do Newton's laws of motion define?
- What are physical examples for each of Newton's three laws of motion?

The English scientist Sir Isaac Newton laid the foundation of mechanics in 1687 with his three laws of motion, which describe the relationship between forces, objects, and motion. Motion can be categorized into two types:

Translation— where a body changes position without changing its orientation in space, and

Rotation— where a body spins about an axis fixed in space, without changing its average position.

Some moving bodies purely translate, others purely rotate, and many do both. Conveniently, we can separate translation and rotation and analyze them individually using independent equations.

Newton's three laws and their implications for translation and rotation are described below.

1.1.1 Newton's 1st Law

Newton's first law states that

an object will remain at rest or in uniform motion in a straight line unless acted upon by an external force.

This law, also sometimes called the “law of inertia,” tells us that bodies maintain their current velocity unless a net force is applied to change it. In other words, an object at rest it will remain at rest and a moving object will hold its current speed and direction unless an unbalanced force causes a velocity change. Remember that velocity is a vector quantity that includes both speed and direction, so an unbalanced force may cause an object to speed up, slow down, or change direction.



Figure 1.1.1 This rock, likely a glacial erratic dropped here in the last ice age, is at rest with zero velocity and will remain at rest until an unbalanced force (like a crane or another ice age) causes it to move.

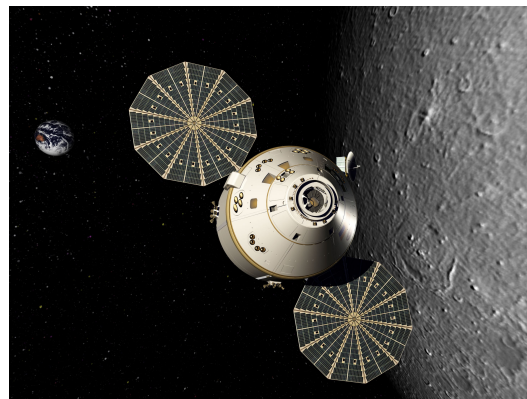

Figure 1.1.2 In deep space, where friction and gravitational forces are negligible, an object moves with constant velocity; near a celestial body gravitational attraction continuously changes its velocity.

Newton's first law also applies to angular velocities, however instead of force, the relevant quantity which causes an object to rotate is called a **torque** by physicists, but usually called a **moment** by engineers. A moment, as you will learn in [Chapter 4](#), is the rotational tendency of a force. Just as a force will cause a change in linear velocity, a moment will cause a change in angular velocity. This can be seen in things like tops, flywheels, stationary bikes, and other objects that spin on an axis when a moment is applied, but eventually stop because of the opposite moment produced by friction.



Figure 1.1.3 A spinning top demonstrates rotary motion.

In the absence of friction this top would spin forever, but the small frictional moment exerted at the point of contact with the table will eventually bring it to a stop.

1.1.2 Newton's 2nd Law

Newton's second law is usually succinctly stated with the familiar equation

$$\mathbf{F} = m\mathbf{a} \quad (1.1.1)$$

where \mathbf{F} is net force, m is mass, and \mathbf{a} is acceleration.

You will notice that the force and the acceleration are in bold face. This means these are vector quantities, having both a magnitude and a direction. Mass on the other hand is a scalar quantity, which has only a magnitude. This equation indicates that a force will cause an object to accelerate in the direction of the net force, and the magnitude of the acceleration will be proportional to the net force but inversely proportional to the mass of the object.

When studying Statics we are only concerned with bodies which are *not* accelerating which simplifies things considerably. When an object is not accelerating $a = 0$, which implies that it is either at rest or moving with a constant velocity. With this restriction Newton's Second Law for translation simplifies to

$$\Sigma\mathbf{F} = 0 \quad (1.1.2)$$

where $\Sigma\mathbf{F}$ is read as "the sum of the forces" and used to indicate the *net* force acting on the object.

Newton's second law for rotational motions is similar

$$\mathbf{M} = I\boldsymbol{\alpha}. \quad (1.1.3)$$

This equation states that a net moment \mathbf{M} acting on an object will cause an angular acceleration $\boldsymbol{\alpha}$ proportional to the net moment and inversely proportional to I , a quantity known as the **mass moment of inertia**. Mass moment of inertia for rotational acceleration is analogous to ordinary mass for linear acceleration. We will have more to say about the moment of inertia in [Chapter 10](#).

Again, we see that the net moment and angular acceleration are vectors, quantities with magnitude and direction. The mass moment of inertia, on the

other hand, is a scalar quantity and has only a magnitude. Also, since Statics deals only with objects which are *not* accelerating $\alpha = 0$, they will always be at rest or rotating with constant angular velocity. With this restriction Newton's second law implies that the net moment on all static objects is zero.

$$\Sigma \mathbf{M} = 0 \quad (1.1.4)$$

1.1.3 Newton's 3rd Law

Newton's Third Law states

For every action, there is an equal and opposite reaction.

The actions and reactions Newton is referring to are **forces**. Forces occur whenever one object interacts with another, either directly like a push or pull, or indirectly like magnetic or gravitational attraction. Any force acting on one body is always paired with another equal-and-opposite force acting on some other body.

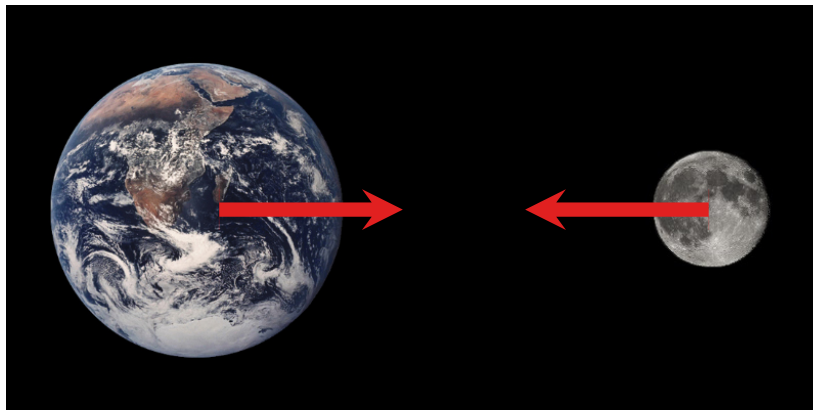

Figure 1.1.4 The earth exerts a gravitational force on the moon, and the moon exerts an equal and opposite force on the earth.

These equal-and-opposite pairs can be confusing, particularly when there are multiple interacting bodies. To clarify, we always begin solving statics problems by drawing a **free-body diagram**— a sketch where we isolate a body or system of interest and identify the forces acting *on* it, while ignoring any forces exerted *by* it on interacting bodies.

Consider the situation in [Figure 1.1.5](#). Diagram (a) shows a book resting on a table supported by the floor. The weights of the book and table are placed at their centers of gravity. To solve for the forces on the legs of the table, we use the free-body diagram in (b) which treats the book and the table as a single system and replaces the floor with the forces of the floor *on* the table. In diagram (c) the book and table are treated as independent objects. By separating them, the

equal-and-opposite interaction forces of the book *on* the table and the table *on* the book are exposed.

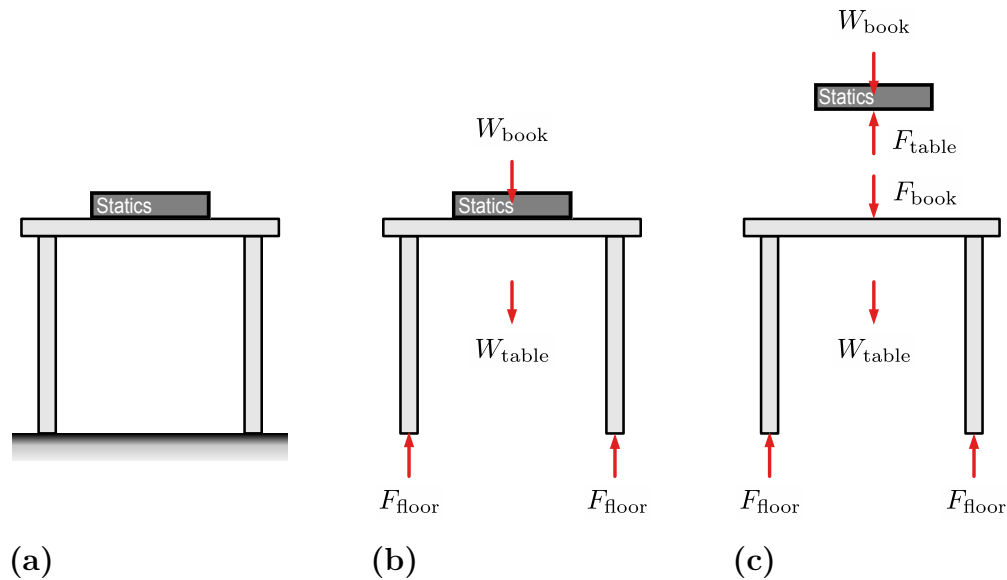

Figure 1.1.5 Free-body diagrams are used to isolate objects and identify relevant forces and moments.

This will be discussed further in [Chapter 3](#) and [Chapter 5](#).

1.2 Units

Key Questions

- What are the similarities and differences between the SI, British Gravitational, and English Engineering unit systems?
- How do you convert a value into different units?
- When a Statics problem give a value in pounds, is this referring to pounds-force or pounds-mass?

Engineering quantities consist of a numeric value and an associated unit (like 150 kg, 9.81 m/s^2 , or 17 ft). The values by themselves (150, 9.81, or 17) are just numbers, but the units give the numbers context. When discussing a quantity, you must *always* include the associated unit. The exceptions to this rule are unitless quantities, which are typically ratios where the units all cancel out.

Related units are defined as a coherent **unit system**. All unit systems are based on seven base units, the important ones for Statics being mass, length, and time. These base units combine to form all other measurement units. For example:

- Acceleration is defined as length $[L]$ divided by time $[t]$ squared, so has

units $a = [L/t^2]$

- Force is the product of mass and acceleration, as defined by [Newton's second law](#), so the units of force are $F = [mL/t^2]$.

1.2.1 Unit Systems

Multiple unit systems are generally used in engineering practice in the United States, including the SI and British Gravitational systems. A third, the English Engineering system, is commonly only used in Physics applications.

The SI system, abbreviated from the French *Système International (d'unités)* is the modern form of the metric system. The SI system is used for most international engineering and increasingly used in the U.S. in fields like science, medicine, electronics, and the military.

In the SI system, the unit of force is the **newton**, abbreviated N , and the unit of mass is the **kilogram**, abbreviated kg . The base unit of time, used by all systems, is the **second**, abbreviated s . Prefixes are added to unit names are used to specify the base-10 multiple of the original unit. One newton is equal to $1 \text{ kg} \cdot \text{m}/\text{s}^2$ because 1 N of force applied to 1 kg of mass causes the mass to accelerate at a rate of $1 \text{ m}/\text{s}^2$.

The other unit systems, British Gravitational and English Engineering, fall under the general name of “Imperial units,” given their broad use in the British Empire. The British Gravitational system uses the **foot**, abbreviated ft , as the base unit of distance, the **second** for time, and the **slug** for mass. Force is expressed in the unit of **pound-force**, abbreviated lbf , or lb for short. One pound-force will accelerate a mass of one slug at $1 \text{ ft}/\text{s}^2$, so $1 \text{ lbf} = 1 \text{ slug} \cdot \text{ft}/\text{s}^2$. On earth, a 1 slug mass weighs 32.174 lbf .

The English Engineering system also uses **foot** as the base unit of distance and **second** for time, but, unlike the British Gravitational system, uses **pound-mass** as the base unit of mass, where

$$32.174 \text{ lbm} = 1 \text{ slug} = 14.6 \text{ kg}.$$

While gravitational acceleration remains the same between the British Gravitational and English Engineering systems, a conversion factor is required to maintain unit consistency.

$$1 = \left[\frac{1 \text{ lbf} \cdot \text{s}^2}{32.174 \text{ ft} \cdot \text{lbm}} \right] = \left[\frac{1 \text{ slug}}{32.174 \text{ lbm}} \right] \quad (1.2.1)$$

The perceived advantage of the English Engineering system is that on Earth, a mass of 1 lbm weighs 1 lbf . However, this numerical equivalence often causes confusion, given the required gravitational conversion factor mentioned in the previous paragraph and the simple fact that mass and weight are different. Mass describes how much matter an object contains, while weight is a force — the effect of gravity on a mass.

Therefore, the U.S. engineering community primarily embraces the British Gravitational system but avoids the mass unit of slugs, instead stating material amounts as weight in pounds-force, or for brevity, pounds.

Table 1.2.1 shows the standard units of weight, mass, length, time, and gravitational acceleration in three unit systems.

Table 1.2.1 Fundamental Units

Unit System	Force	Mass	Length	Time	g (Earth)
SI	N	kg	m	s	9.81 m/s ²
British Gravitational	lbf	slug	ft	s	32.2 ft/s ²
English Engineering	lbf	lbm	ft	s	1 lbf/1 lbm

Thinking Deeper 1.2.2 Pounds Mass vs. Pounds Force.

The confusion caused by U.S. engineering students learning about the pounds-mass + pounds-force system in Physics, closely followed by adopting a slugs + pounds-force system in Statics, often leads students to ask “Is this pound a mass or force?” to which Statics faculty commonly respond “All pounds are forces in Statics.”

Below you’ll find an online song and the lyrics that Dan Baker created to help students remember that all pounds in Statics are pounds-force.

Here’s the [link to the Song “Pounds are a Force” at Suno.com](#).

Pounds are a Force

Our world is engineering, let's get it right,
Pounds are a force, not mass in our sight.
We measure with care, we never confuse,
Pounds-mass is a unit that we never use.

[chorus]
Pounds are force, feel their weight,
That is what Engineers calculate.
SI uses Kilograms for mass, Newtons for force,
But in the U.S. we are different of course.

Gravity pulls, and we feel the strain,
Newtons and pounds, they make it plain.
Kilograms and slugs, they are the masses,
The amount of material across our classes.

[chorus]
Pounds are force, feel their weight,
That is what Engineers calculate.
SI uses Kilograms for mass, Newtons for force,
But in the U.S. we are different of course.

From meters to feet, we can convert,
9.81 meters is simply 32.2 feet, that's certain.
So don't ask: do we multiply or divide?
Just write $W = mg$, and then decide.

[chorus]
Pounds are force, feel their weight,
That is what Engineers calculate.
SI uses Kilograms for mass, Newtons for force,
But in the U.S. we are different of course.

So when you measure, know your course,
In engineering, pounds are force.
Leave pounds mass back in the dust,
In the US Customary System we trust.

By Dan Baker, with lyrics assistance from ChatGPT and song composed by Suno.com.

1.2.2 Units within Newton's 2nd Law

Given that Newton's 2nd Law, $\Sigma \mathbf{F} = m\mathbf{a}$, is one of the foundational equations in engineering mechanics and the most basic equation relating mass and weight, let's examine its use in more detail. First we need to relate $\Sigma \mathbf{F} = m\mathbf{a}$ to weight, mass, and gravity. Consider an object in free fall. The only vertical force on the body is its weight W ; thus, the object's mass m is accelerated by gravity g . Therefore, we can transform Newton's 2nd Law $\Sigma \mathbf{F} = m\mathbf{a}$ to $\mathbf{W} = m\mathbf{g}$.

The scalar version, $W = mg$, also serves as the conversion equation among weight, mass, and gravity. You likely know this relationship for problems using the SI system. Hence, if you are given a 100 kg object here on earth and are asked to find the weight, you compute:

$$\begin{aligned} W &= mg \\ W &= 100 \text{ kg } (9.81 \text{ m/s}^2) \\ W &= 981 \text{ N} \end{aligned}$$

The confusion often starts when students in the United States are asked to find the mass of a known-weight object. Let's say you are asked to find the mass of a 100 lb object. Given the U.S. engineering convention that all pounds are force, the *lb* unit listed in the problem is pounds-force. Here's the root of the confusion: ***SI problems give an object's mass, while U.S. problems give an object's weight.*** Life would be easier if this was not the case, but never fear — we can use $W = mg$ to solve the problem. This time we will solve for m instead of W .

$$\begin{aligned} W &= mg \\ 100 \text{ lb} &= m \text{ } 32.2 \text{ ft/s}^2 \\ m &= \frac{100 \text{ lb}}{32.2 \text{ ft/s}^2} \\ m &= 3.1 \text{ slug} \end{aligned}$$

Next we will investigate the values of the gravitational acceleration constant in SI and the British Gravitational system. As both measure the acceleration of an object toward the Earth, it should make sense that they are equivalent:

$$g = 9.81 \text{ m/s}^2 \left(\frac{3.28 \text{ ft}}{1 \text{ m}} \right) \approx 32.2 \text{ ft/s}^2$$

As shown in this unit conversion, *always make sure to multiply terms by the correct ratios* to get your desired units. In this case we multiplied by (3.28 ft/1 m) with meters in the bottom so it cancels out with the meters in the top of 9.81 m/s².

Here are two examples to test your understanding of the relationships among weight, mass, and gravity.

Example 1.2.3

How much does a 5 kg bag of flour weigh on Earth?

Hint. A value in kg is a mass. Weight is a force.

Solution.

$$\begin{aligned}W &= mg \\ &= 5 \text{ kg}(9.81 \text{ m/s}^2) \\ &= 49.05 \text{ N}\end{aligned}$$

Example 1.2.4

How much does a 5 lb bag of sugar weigh?

Hint. When a problem says *pounds*, it is referring to *pounds-force*.

Solution. The weight was given:

$$W = 5 \text{ lb} = 5 \text{ lbf.}$$

If you needed the *mass in slugs*, the mass is

$$m = \frac{5 \text{ lbf}}{32.2 \text{ ft/s}^2} = 0.155 \text{ slug.}$$

1.2.3 Avoiding Common Unit Errors

Awareness of units will help you prevent errors in your engineering calculations. You should always:

- Pay attention to the units of every quantity in the problem. Forces should have force units, distances should have distance units, etc.
- Use the unit system given in the problem statement and ensure any constants used agree with the units of the other terms. For example, $g = 9.81 \text{ m/s}^2$ should only be used when the rest of the problem is in SI units, matching the units of m and s.
- Avoid unit conversions when possible. If you must, convert given values to a consistent set of units and stick with them.
- Ensure unit consistency in your calculations. You can only add or subtract quantities with the same units. When multiplying or dividing quantities with units, apply the same operation to the units. Finally, the units on both sides of an equation must match.

- Develop a sense of the magnitudes of the units and consider your answers for reasonableness. On Earth, the four commonly used masses and weights, from smallest to largest, are roughly equivalent to:

Newton = 1 apple,
pound-force = box of butter,
kilogram = a pineapple, and
slug = a medium dog (like a Corgi).

- Assume every answer in Statics, and engineering in general, has units. A few answers will be dimensionless, but not many.

Understanding the relationship between weight, mass, and gravitational acceleration is essential for solving Statics problems. Always identify whether weight or mass is given and use $W = mg$ with the correct gravitational acceleration. This intentional process will help you confidently work across both SI and U.S. unit systems.

1.3 Forces

Key Questions

- What are some of the fundamental types of forces used in statics?
- Why do we often simplify distributed forces with equivalent point forces?

A force is simply a linear push or pull, yet forces come from a variety of sources and occur in many different situations. As such we need a specialized vocabulary to talk about them. We are also interested in forces that cause rotation, and we have special terms to describe these too.

Some terms used to describe forces are given below; others will be defined as needed later in the book.

Point Forces, also called **concentrated forces**, are forces that act at a single point. Examples are the push you give to open a door, the thrust of a rocket engine, or the pull of the chain suspending a wrecking ball. Point forces are actually an idealization, because real forces always act over an area and not at a mathematical point. However, point forces are the easiest type to deal with computationally so we will usually represent other types of forces as equivalent concentrated forces.

Distributed forces are forces that are spread out over a line, area or volume. Water pressure on the side of a swimming pool and the weight of snow on a roof are examples of forces distributed over an area. Distributed forces are represented graphically by an array of force vectors.

Body forces are distributed forces acting over the volume of a body. The most common body force is the body's weight, but there are others including buoyancy and forces caused by electric and magnetic fields. Weight and buoyancy will be the only body forces we consider in this book.

In many situations, body forces are small in comparison to the other forces acting on the object, and as such may be neglected. In practice, the decision to neglect forces must be made on the basis of sound engineering judgment; however, in this course you should consider the weight in your analysis if the problem statement provides enough information to determine it, otherwise you may ignore it.

Loads are the forces which an object must support in order to perform its function. Loads can be either static or dynamic, however only static loads will be considered here. Forces which hold a loaded object in equilibrium or hold parts of an object together are not considered loads.

Reaction forces or simply **reactions** are the forces and moments which hold or constrain an object or mechanical system in equilibrium. They are called the reactions because they react when other forces on the system change. If the load on a system increases, the reaction forces will automatically increase in response to maintain equilibrium. Reaction forces are introduced in [Chapter 3](#) and reaction moments are introduced in [Chapter 5](#).

Interaction forces are forces that exist between rigid bodies. They are defined by Newton's 3rd Law as being equal and opposite. Interaction forces become important in [Chapter 6](#) when working with multi-body structures.

Internal forces are forces and moments that exist within the material of a rigid body that resist the external loads to keep the rigid body from breaking. We model these internal loads as an axial force, a shear force, and a bending moment. Internal forces will be discussed in [Chapter 8](#).

The figure below illustrates multiple of these force types using a heavy crate being pulled by a rope across a rough surface.

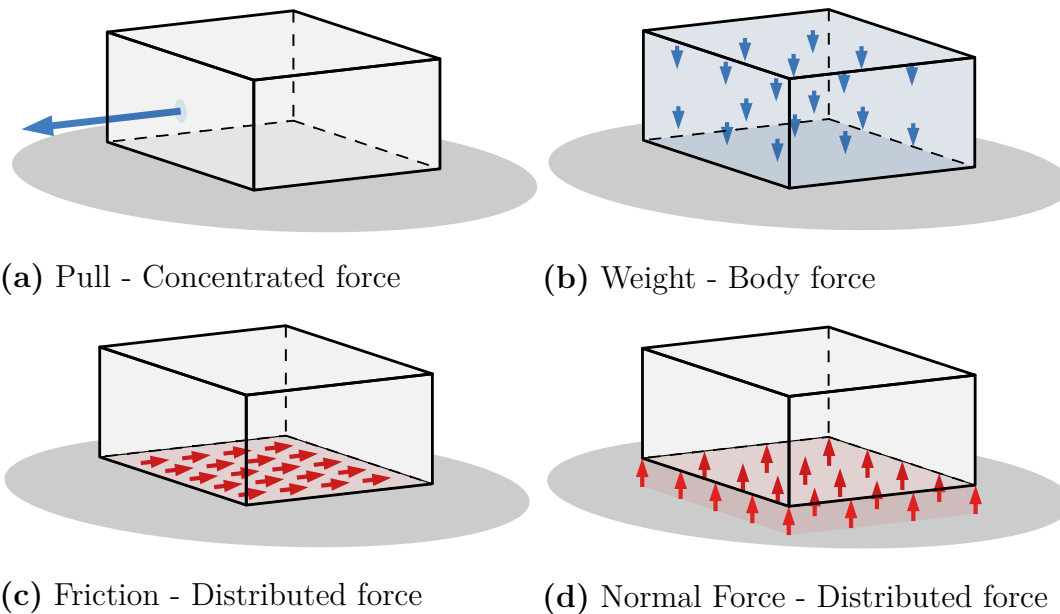

Figure 1.3.1 Forces on a crate being pulled across a rough surface.

The pull of the rope and the weight of the crate are *loads*. The rope applies a force at a single point, so is a *concentrated force*. The force of the ground holding the crate in equilibrium is a *reaction force*. This force can be divided into two components: a **tangential** friction component which acts parallel to the ground and resists the pull of the cable, and a **normal** component which acts perpendicular to the bottom surface and supports the crate's weight. The normal and tangential components are *distributed forces* since they act over the bottom surface area. The weight is also a distributed force, but one that acts over the entire crate so it's considered a *body force*. For computational simplicity we usually model all these distributed forces as equivalent concentrated forces. This process is discussed in [Chapter 7](#).

1.4 Problem Solving

Key Questions

- What are some strategies to practice selecting a tool from your problem-solving toolbox?
- What is the basic problem-solving process for equilibrium?

Statics may be the first course you take where you are required to decide on your own how to approach a problem. Unlike your previous Physics courses, you can't just memorize a formula and plug-and-chug to get an answer; there are often multiple ways to solve a problem, not all of them equally easy, so before you begin you need a plan or strategy. This seems to cause a lot of students difficulty.

The ways to think about forces, moments and equilibrium, and the mathematics used to manipulate them are like tools in your toolbox. Solving statics problems requires acquiring, choosing, and using these tools. Some problems can be solved with a single tool, while others require multiple tools. Sometimes one tool is a better choice, sometimes another. You need familiarity and practice to get skilled using your tools. As your skills and understanding improve, it gets easier to recognize the most efficient way to get a job done.

Struggling statics students often say things like:

“I don’t know where to start the problem.”

“It looks so easy when you do it.”

“If I only knew which equation to apply, I could solve the problem.”

These statements indicate that the students think they know how to use their tools, but are skipping the planning step. They jump right to writing equations and solving for things without making much progress towards the answer, or they start solving the problem using a reasonable approach but abandon it in mid-stream to try something else. They get lost, confused and give up.

Choosing a strategy gets easier with experience. Unfortunately, the way you get that experience is to solve problems. If you think that this is a chicken and egg problem, you are correct. Here are some suggestions which will help you become a better problem-solver.

- Hone your math skills, in the areas of algebra, trigonometry, and calculus. These are complimentary tools to solve engineering problems, but only help after you get the problem set up.
- Build your understanding of the terminology. If you do not understand the words in the problem statement, then you will have difficulty setting up your equations to solve the problem.
- Every engineering equation comes with assumptions. Learn these assumptions so you can decide whether a specific equation is valid within the context of a problem.
- Work through, or at least set up, lots of problems. Start with simple ones to build your skills.
- Start by viewing examples or videos, but progress to working problems on your own. Seeing someone else’s solution will make you overconfident that you can do the same thing. The only way you’ll know is to try on your own.
- Solve problems using multiple approaches. Confirm that alternate approaches produce the same results and try to understand why one method was easier than the other.

- Draw neat, clear, labeled diagrams.
- When you get frustrated, you have just found something new to learn. Don't get stuck for more than 15-20 minutes. Work to identify what is confusing you and find informative resources or ask questions.

The majority of the topics in this book focus on equilibrium. The remaining topics are either preparing you for solving equilibrium problems or setting you up with skills that you will use in later classes. For equilibrium problems, the problem-solving steps are:

1. Read and understand the problem.
2. Identify what you are asked to find and what is given.
3. Stop, think, and decide on an strategy.
4. Draw a free-body diagram with all the required elements:
 - (a) An isolated body or group of bodies
 - (b) All applied loads
 - (c) All reactions from supports
 - (d) An axis system
 - (e) Labeled vectors
5. Write equations of equilibrium based on the free-body diagram.
6. Check if the number of equations equals the number of unknowns. If it doesn't, you are missing something. You may need additional free-body diagrams or other relationships.
7. Solve for unknowns, then evaluate the reasonableness of your answer(s) magnitude, units, and sign/direction.

Using these steps does not guarantee that you will get the right solution, but it will help you be critical and conscious of your chosen strategies. This reflection will help you learn more quickly and increase the odds that you choose the right tool for the job.

Chapter 2

Forces and Other Vectors

To progress to the later topics of static equilibrium, structures, and friction, you will need to first build a robust set of basic vector analysis skills. These skills include:

- Understanding the basic terminology around vectors.
- Computing vector components from the various ways that vector magnitude and direction can be defined.
- Extracting vector direction in the form of a unit vector.
- Adding and subtracting vectors.
- Finding the parallel projections of vectors with dot products.
- Computing cross products to find the rotational tendency of forces.

This chapter will help you build this skillset. You may notice that many of the tools in this chapter are also covered in your Calculus III course. Use this overlap to your advantage to dial in your computational skills in calculus, while learning about the application of the math tools here in statics.

2.1 Vectors

Key Questions

- What differentiates a vector from a scalar?
- What are the standard notations for vectors and scalars in this textbook?
- How do you identify the tip, tail, line of action, direction, and magnitude of a vector?

- What is the difference between the sense and orientation of a vector?

Before you can solve statics problems, you will need to understand the basic physical quantities used in Statics: scalars and vectors.

Scalars are physical quantities that have no associated direction and can be described by a positive or negative number, or even zero. Scalar quantities follow the usual laws of algebra, and most scalar quantities have units. Mass, time, temperature, and length are all scalars.

Vectors represent physical quantities that have magnitude and direction. Vectors are identified by a symbolic name which will be typeset in bold like \mathbf{r} or \mathbf{F} to indicate its vector nature. The primary vector quantity you will encounter in statics will be **force**, but **moment** and **position** are also important vectors. Computations involving vectors must always consider the directionality of each term and follow the rules of vector algebra as described in this chapter.

You can visualize a vector as an **arrow** pointing in a particular direction. The **tip** is the pointed end and the **tail** the trailing end. The tip and tail of a vector define a **line of action**. A line of action can be thought of as an invisible string along which a vector can slide. Sliding a vector along its line of action does not change its magnitude or its direction. Sliding a vector can be a handy way to simplify vector problems.

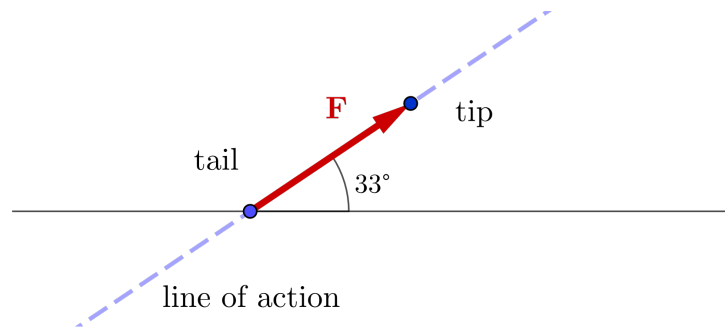

[Live Link](#)

Figure 2.1.1 Vector Definitions

The standard notation for a vector uses the vector's name in bold font, or an arrow or bar above the vector's name. All three of these notations mean the same thing.

$$\mathbf{F} = \vec{F} = \bar{F} = \text{a vector named } F$$

Most printed works including this book will use the bold symbol to indicate vectors, but for handwritten work, you and your instructor will use the bar or arrow notation.

Force vectors acting on physical objects have a **point of application**, which

is the point where the force is applied. Other vectors, such as moment vectors, are **free vectors**, which means that the point of application is not significant. Free vectors can be moved freely to any location as long as the magnitude and direction are maintained.

The vector's **magnitude** is a *positive real number* including units which describes the 'strength' or 'intensity' of the vector. Graphically a vector's magnitude is represented by the length of its vector arrow, and symbolically by enclosing the vector's symbol with vertical bars. This is the same notation as for the absolute value of a number. The absolute value of a number and the magnitude of a vector can both be thought of as a distance from the origin, so the notation is appropriate. By convention the magnitude of a vector is also indicated by the same letter as the vector, but in non-bold font.

$$F = |\mathbf{F}| = \text{the magnitude of vector } \mathbf{F}$$

By itself, a vector's magnitude is a scalar quantity, but it makes no sense to speak of a vector with a negative magnitude so vector magnitudes are always positive or zero. Multiplying a vector by -1 produces a vector with the same magnitude but pointing in the opposite direction.

Vector directions are described with respect to a **coordinate system**. A coordinate system is an arbitrary reference system used to establish the **origin** and the primary directions. Distances are usually measured from the origin, and directions from a primary or **reference direction**. You are probably familiar with the Cartesian coordinate system with mutually perpendicular x , y and z axes and the origin at their intersection point.

Another way of describing a vector's direction is to specify its **orientation** and **sense**. Orientation is the angle the vector's line of action makes with a specified reference direction, and sense defines the direction the vector points along its line of action. A vector with a positive sense points towards the positive end of the reference axis and vice-versa. A vector representing an object's weight has a vertical reference direction and a downward sense or negative sense, for example.

A third way to represent a vector is with a **unit vector** multiplied by a **scalar component**. Unit vectors (which we'll learn about in [Section 2.5](#)) are vectors with a magnitude of one (unitless), and scalar components are signed values with units. Together, they fully define a vector quantity; the unit vector specifies the direction of its line of action, and the scalar component specifies its magnitude and sense. The scalar component "scales" the unit vector.

Be careful not to confuse scalar components, which can be positive or negative, with vector magnitudes, which are always positive.

Vectors are either constant or vary as a function of time, position, or something else. For example, if a force varies with time according to the function $F(t) = (10 \text{ N/s})t$, where t is the time in seconds, then the force will be 0 N at $t = 0$ s and increase by 10 N each second thereafter.

2.2 One-Dimensional Vectors

Key Questions

- Why is one-dimensional vector math just like scalar math?
- Given two one-dimensional vectors, how do you compute and then draw the resultant?
- What happens when you multiply a vector by a scalar?

The simplest vector calculations involve one-dimensional vectors. With one-dimensional vectors, vector arithmetic is the same as *ordinary* arithmetic.

By definition, one-dimensional vectors all act along a single line. The line they share is called the **line of action**, but note that vectors that act along a line may point towards either end.

If we place a coordinate axis along the line of action and give vectors that point towards the positive end *positive* values equal to their magnitudes, and give vectors that point the other way *negative* values, then the vectors add, subtract and multiply by constants just like ordinary numbers along the number line. The resulting sign indicates the direction of the result. Note that, by convention, the labeled end of an axis is the positive end.

2.2.1 Vector Addition

Adding multiple vectors together finds the **resultant** vector. Resultant vectors can be thought of as the *sum* of or *combination* of two or more vectors.

To find the resultant vector **R** of two one-dimensional vectors **A** and **B** you can use the tip-to-tail technique in Figure 2.1.1 below. In the tip-to-tail technique, you slide vector **B** until its tail is at the tip of **A**, and the vector from the tail of **A** to the tip of **B** is the resultant **R**. Note that vector addition is commutative: the resultant **R** is the same whether you add **A** to **B** or **B** to **A**.

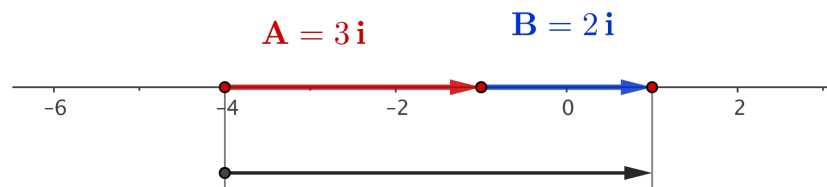

[Live Link](#)

Figure 2.2.1 One Dimensional Vector Addition

2.2.2 Vector Subtraction

The easiest way to handle vector subtraction is to add the negative of the vector you are subtracting to the other vector. In this way, you can still use the tip-to-tail technique after flipping the vector you are subtracting.

$$\mathbf{A} - \mathbf{B} = \mathbf{A} + (-\mathbf{B}) \quad (2.2.1)$$

Example 2.2.2 Vector subtraction.

Find $\mathbf{A} - \mathbf{B}$ where $\mathbf{A} = 2 \mathbf{i}$ and $\mathbf{B} = 3 \mathbf{i}$.

Solution. You can simulate this in [Figure 2.2.1](#).

1. Set \mathbf{A} to a value of $2 \mathbf{i}$ and \mathbf{B} to a value of $-3 \mathbf{i}$, the negative of its actual value.
2. Move the vectors until they are tip-to-tail. The order does not matter because vector addition is commutative.

$$\mathbf{R} = -1 \mathbf{i}.$$

2.2.3 Vector Multiplication by a Scalar

Multiplying or dividing a vector by a scalar changes the vector's magnitude but maintains its original line of action. In other words, multiplying a vector by a scalar "scales" the vector.

One common transformation is to find the negative of a vector. To find the negative of vector \mathbf{A} , we multiply it by -1 ; in equation form

$$-\mathbf{A} = (-1)\mathbf{A}$$

Spatially, the effect of multiplying a vector by -1 , is to reverse it end for end. The magnitude and line of action stay the same, but the sense reverses, so now the arrowhead points in the opposite direction. When multiplying vector components by -1 , simply flip the $+/-$ sign of each term to flip the direction of the vector.

2.3 2D Coordinate Systems & Vectors

Key Questions

- Why are orthogonal coordinate systems useful?
- How do you transform between polar and Cartesian coordinates?

- How is the notation for point coordinates different than that of vector coordinates?

A coordinate system provides a reference frame to describe a system we want to analyze. Although there are many different coordinate systems that can be used, selecting an appropriate one will make a problem easier to solve.

In statics, we use **orthogonal** coordinate systems, where orthogonal means “perpendicular.” The advantage of orthogonal coordinate systems is that the coordinate directions are all perpendicular and, therefore, independent. The intersection of the coordinate axes is called the **origin**, and measurements are made from there. Both points and vectors are described with a set of numbers called the **coordinates**. For points in space, the coordinates specify the distance you must travel in each of the coordinate directions to get from the origin to the point in question. Together, the coordinates can be thought of as specifying a **position vector**, a vector from the origin directly to the point. The position vector gives the magnitude and direction needed to travel directly from the origin to the point.

In the case of force vectors, the coordinates are the **scalar components** of the force in each of the coordinate directions. These components locate the tip of the vector and they can be interpreted as the fraction of the total force which acts in each of the coordinate directions.

Three coordinate directions are needed to map our real three-dimensional world but in this section we will start with two, simpler, two-dimensional orthogonal systems: **rectangular** and **polar** coordinates, and the tools to convert from one to the other.

2.3.1 Rectangular Coordinates

The most important coordinate system is the **Cartesian** system, which was named after the French mathematician René Descartes. In two dimensions the coordinate axes are straight lines rotated 90° apart named x , and y .

In most cases, the x axis is horizontal and points to the right, and the y axis points vertically upward, however, we are free to rotate or translate this entire coordinate system if we like. It is usually mathematically advantageous to establish the origin at a convenient point to make measurements from, and to align one of the coordinate axes with a major feature of the problem.

Points are specified as an ordered pair of coordinate values separated by a *comma* and enclosed in parentheses, $P = (x, y)$.

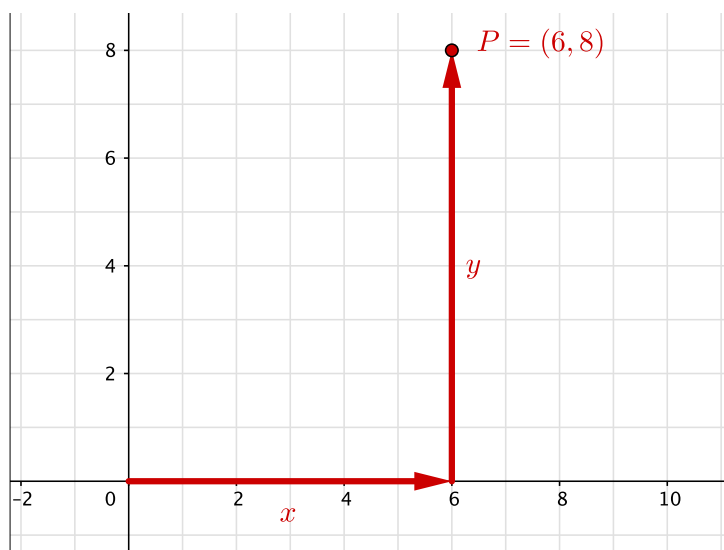

[Live Link](#)

Figure 2.3.1 Cartesian Coordinate System

Similarly, forces and other vectors will be specified with an ordered pair of scalar components enclosed by angle brackets,

$$\mathbf{F} = \langle F_x, F_y \rangle.$$

2.3.2 Polar Coordinates

The **polar** coordinate system is an alternate orthogonal system which is useful in some situations. In this system, a point is specified by its distance r from the origin, and an angle θ measured counter-clockwise from a reference direction – usually the positive x axis. Polar coordinates are useful if we know more about distances and angles from a central point. Examples of systems that would use polar coordinates would be tower cranes to build skyscrapers, robotic arm motion, and radar systems.

In this text, points in polar coordinates will be specified as an ordered pair of values separated by a *semicolon* and enclosed in parentheses

$$P = (r; \theta).$$

Angles can be measured in either radians or degrees, so be sure to include a degree sign on angle θ if that is what you intend.

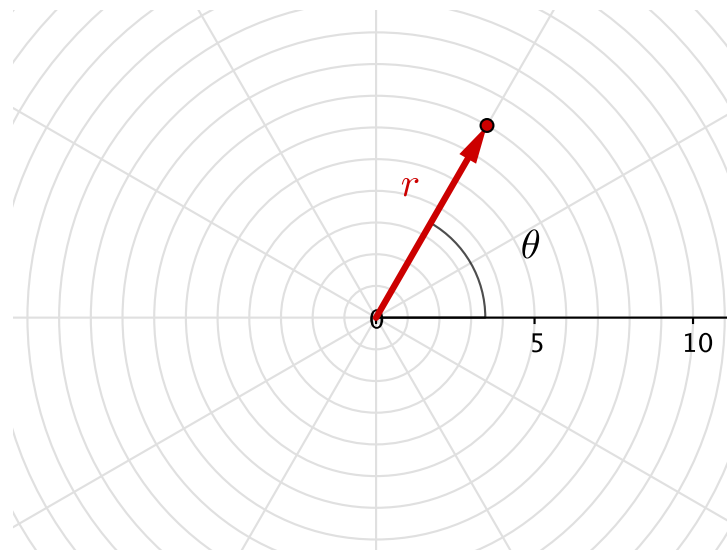

[Live Link](#)

Figure 2.3.2 Polar Coordinate System

2.3.3 Coordinate Transformation

You should be able to translate points from one coordinate system to the other whenever necessary. The relation between (x, y) coordinates and $(r; \theta)$ coordinates are illustrated in the diagram and right-triangle trigonometry is all that is needed to convert from one representation to the other.

Luckily, it is quite easy to translate points between the rectangular (x, y) and polar $(r; \theta)$ coordinate systems using right-triangle trigonometry. As you move point P around the figure below, you can see how the two coordinate types are related.

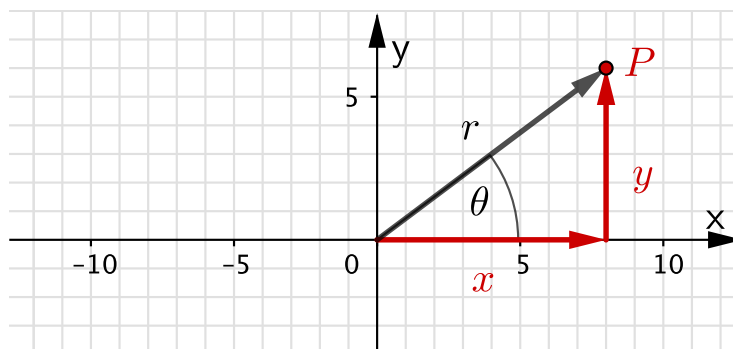

[Live Link](#)

Figure 2.3.3 Coordinate Transformation

Rectangular To Polar for points (Given: x and, y).

$$r = \sqrt{x^2 + y^2} \quad (2.3.1)$$

$$\theta = \tan^{-1} \left(\frac{y}{x} \right) \quad (2.3.2)$$

$$P = (r ; \theta) \quad (2.3.3)$$

Note 2.3.4

Take care when using the inverse tangent function on your calculator. Calculator angles are always in the first or fourth quadrant, and you may need to add or subtract 180° to the calculator angle to locate the point in the correct quadrant.

Polar to Rectangular for points (Given: r and, θ).

$$x = r \cos \theta \quad (2.3.4)$$

$$y = r \sin \theta \quad (2.3.5)$$

$$P = (x, y) \quad (2.3.6)$$

Rectangular To Polar for forces (Given: rectangular components). If you are working with forces rather than distances, the process is exactly the same but triangle is labeled differently. The hypotenuse of the triangle is the magnitude of the vector, and sides of the right triangle are the scalar components of the force, so for vector \mathbf{A}

$$A = \sqrt{A_x^2 + A_y^2} \quad (2.3.7)$$

$$\theta = \tan^{-1} \left(\frac{A_y}{A_x} \right) \quad (2.3.8)$$

$$\mathbf{A} = (A; \theta) \quad (2.3.9)$$

Polar to Rectangular for forces (Given: magnitude and direction).

$$A_x = A \cos \theta \quad (2.3.10)$$

$$A_y = A \sin \theta \quad (2.3.11)$$

$$\mathbf{A} = \langle A_x, A_y \rangle = A \langle \cos \theta, \sin \theta \rangle \quad (2.3.12)$$

Example 2.3.5 Rectangular to Polar Representation.

Express point $P = (-8.66, 5)$ in polar coordinates.

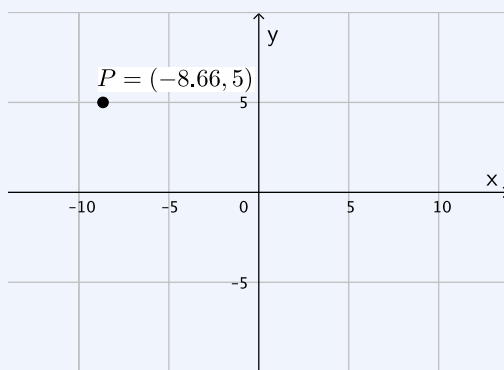

Solution 1. Given: $x = -8.66$, $y = 5$

$$\begin{aligned} r &= \sqrt{x^2 + y^2} & \theta &= \tan^{-1} \left(\frac{y}{x} \right) \\ &= \sqrt{(-8.66)^2 + (5)^2} & &= \tan^{-1} \left(\frac{5}{-8.66} \right) \\ &= 10 & &= \tan^{-1}(-0.577) \\ & & &= -30^\circ \end{aligned}$$

You must be careful here and use some common sense. The -30° angle your calculator gives you in this problem is incorrect because point P is in the second quadrant, but your calculator doesn't know this. It can't tell whether the argument of $\tan^{-1}(-0.577)$ is negative because the x was negative or because the y was negative, so it must make an assumption and in this case it is wrong.

The arctan function on calculators will always return values in the first and fourth quadrant. If, by inspection of the x and the y coordinates, you see that the point is in the second or third quadrant, you must add or subtract 180° to the calculator's answer.

So in this problem, θ is really $-30^\circ + 180^\circ$. After making this adjustment, the location of P in polar coordinates is:

$$P = (10; 150^\circ)$$

Solution 2. Most scientific calculators include handy polar-to-rectangular and rectangular-to-polar functions that can save you time and help you avoid errors. Perhaps you should [google your calculator model](#) to find out if yours does and learn how to use it?

Example 2.3.6 Polar to Rectangular Representation.

Express 200 N force \mathbf{F} as a pair of scalar components.

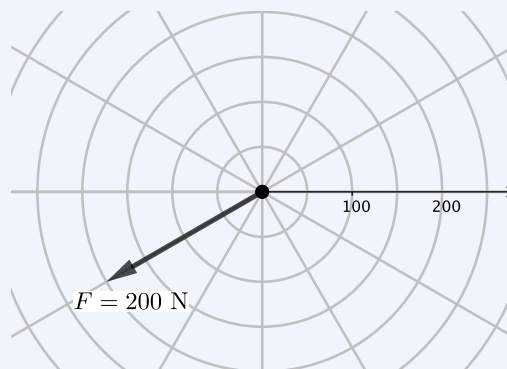

Solution 1. Given: The magnitude of force $\mathbf{F} = 200$ N, and from the diagram we see that the direction of \mathbf{F} is 30° counter-clockwise from the negative x axis.

Letting $\theta = 30^\circ$ we can find the components of \mathbf{F} with right triangle trigonometry.

$$\begin{aligned} F_x &= F \cos \theta & F_y &= F \sin \theta \\ &= 200 \text{ N} \cos 30^\circ & &= 200 \text{ N} \sin 30^\circ \\ &= 173.2 \text{ N} & &= 100 \text{ N} \end{aligned}$$

Since the force points down and to the left into the third quadrant, these values are actually negative, and the signs must be applied manually.

After making this adjustment, the location of \mathbf{F} expressed in rectangular coordinates is:

$$\mathbf{F} = \langle -173.2 \text{ N}, -100 \text{ N} \rangle$$

Solution 2. If you would prefer not to apply the negative signs by hand, you can convert the 30° to an angle measured from the positive x axis and let your calculator take care of the signs. You may use either $\theta = 30^\circ \pm 180^\circ$.

For $\theta = -150^\circ$

$$\begin{aligned} F_x &= F \cos \theta & F_y &= F \sin \theta \\ &= 200 \text{ N} \cos(-150^\circ) & &= 200 \text{ N} \sin(-150^\circ) \\ &= -173.2 \text{ N} & &= -100 \text{ N} \end{aligned}$$

$$\mathbf{F} = \langle -173.2 \text{ N}, -100 \text{ N} \rangle$$

Although this approach is mathematically correct, experience has shown that it can lead to errors and we recommend that when you work with right triangles, use angles between zero and 90° , and apply signs manually as required by the physical situation.

2.4 3D Coordinate Systems & Vectors

Key Questions

- How can we check if a rectangular coordinate system follows the right-hand rule?
- What are direction cosine angles and why are they always less than 180° ?
- How are spherical coordinates different than cylindrical coordinates?

In this section we will discuss four methods to specify points and vectors in three-dimensional space.

The most commonly used method is an extension of two-dimensional **rectangular coordinates** to three-dimensions. Alternately, points and vectors in three dimensions can be specified in terms of **direction cosines**, or using **spherical** or **cylindrical** coordinate systems. These will be discussed in the following sections.

You will often need to convert from one representation to another. Good visualization skills are helpful here.

2.4.1 Rectangular Coordinates

We can extend the two-dimensional Cartesian coordinate system into three dimensions easily by adding a z axis perpendicular to the two-dimensional Cartesian plane. The notation is similar to the notation used for two-dimensional vectors. Points and forces are expressed as ordered triples of rectangular coordinates following the same notation used previously.

$$P = (x, y, z)$$

$$\mathbf{F} = \langle F_x, F_y, F_z \rangle$$

For nearly all three-dimensional problems, you will need the rectangular x , y , and z locations of points in space and components of vectors before proceeding with the computations. If you are given the components upfront, then you are set to move forward, but otherwise, you will need to transform one coordinate system into rectangular coordinates.

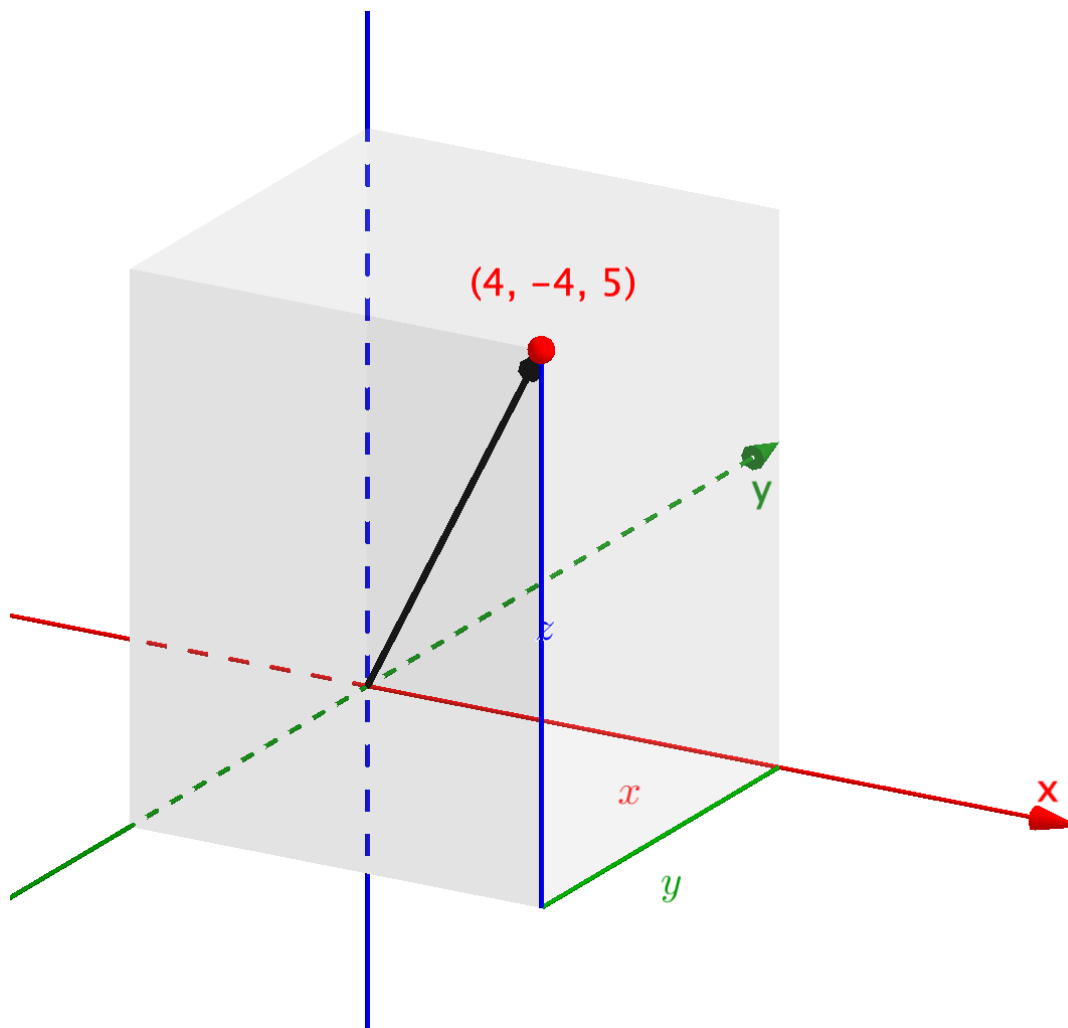

Live Link

Figure 2.4.1 Three-Dimensional Rectangular Coordinates

Thinking Deeper 2.4.2 Right-Handed Coordinate Systems.

Does it matter which way the axes are oriented? Is it OK to make the x axis point left or the y axis point down?

The answers to the questions above, like so many in life, are "It depends." If you are simply summing the forces of a system, you typically can select any perpendicular axes you wish, but for systems involving any cross-product relationships (like the rotational moments you'll learn about in [Chapter 4](#)), we need to use a standard orientation. In mathematics and engineering, the default is a **right-handed coordinate system**, where the coordinate axes are oriented according to the **right-hand rule** shown in the figure.

To apply the right-hand rule, orient your thumb and first two fingers at right angles to each other and align them with three coordinate axes. Starting with your thumb, name the axes in alphabetical order x - y - z . In mathematical terms, when we cross the x -axis into the y -axis, we need to get the direction of the z -axis.

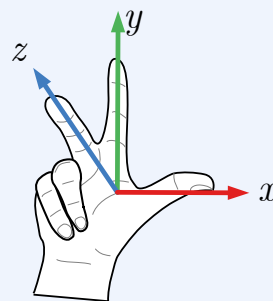

Figure 2.4.3 Right-handed coordinate system.

2.4.2 Direction Cosine Angles

The direction of a vector in two-dimensional systems could be expressed clearly with a single angle measured from a reference axis, but adding an additional dimension means that one angle is no longer enough.

One way to define the direction of a three-dimensional vector is by using **direction cosine angles**, also commonly known as **coordinate direction angles**. The direction cosine angles are the angles between the positive x , y , and z axes to a given vector and are traditionally named θ_x , θ_y , and θ_z . Three-dimensional vectors, components, and angles are often difficult to visualize because they do not commonly lie in the Cartesian planes.

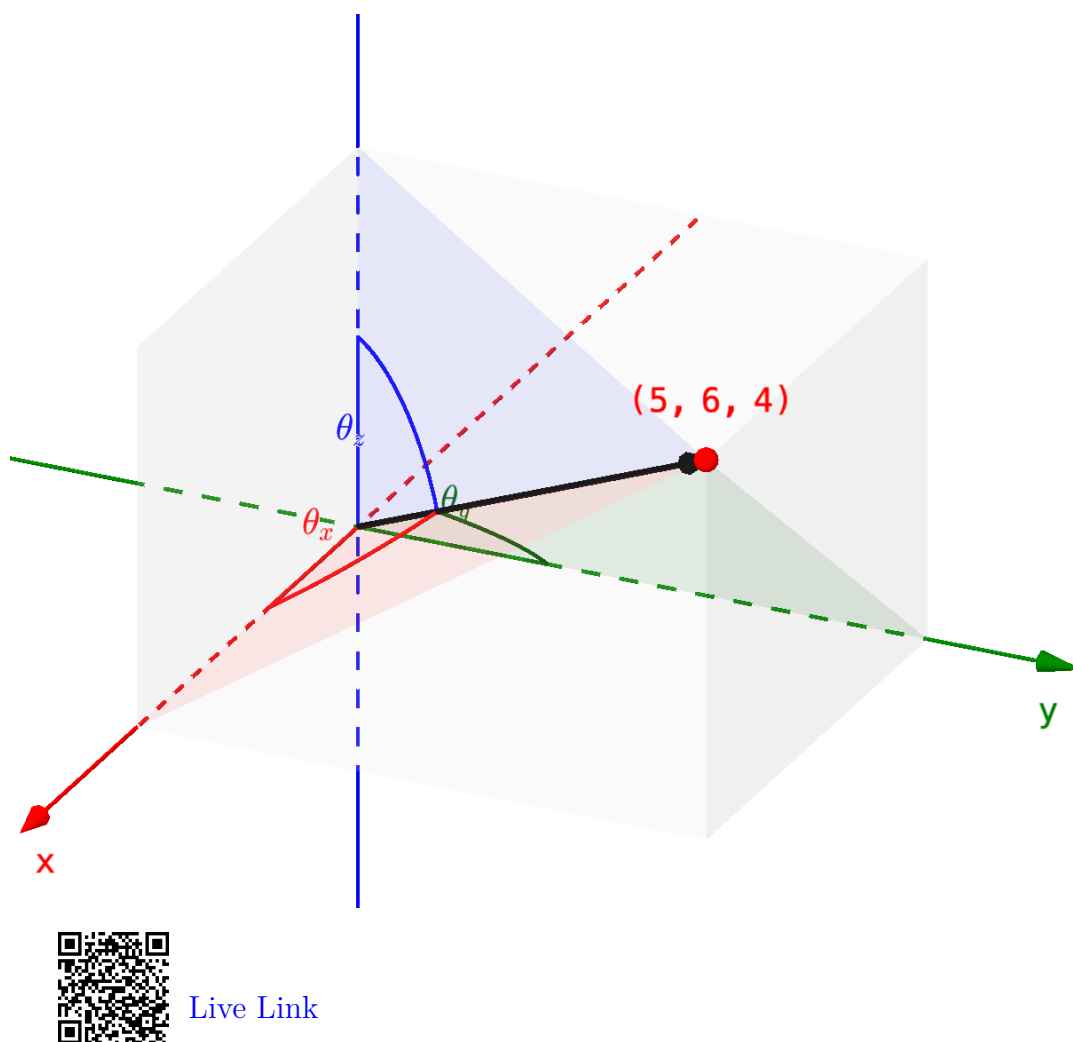

Figure 2.4.4 Direction Cosine Angles

We can relate the components of a vector to its direction cosine angles using the following equations.

$$\cos \theta_x = \frac{A_x}{|A|} \quad \cos \theta_y = \frac{A_y}{|A|} \quad \cos \theta_z = \frac{A_z}{|A|} \quad (2.4.1)$$

These cosine relationships come from the red, green, and blue right triangles shown in [Figure 2.4.4](#), where the side adjacent to each angle is the component and the hypotenuse is the full vector. Note that the component in the numerator of each direction cosine equation is positive or negative as defined by the coordinate system, and the vector magnitude in the denominator is always positive.

From these equations, we can conclude that:

- Direction cosines are signed value between -1 and 1.
- Direction cosine angles must always be between 0° and 180° or

$$0^\circ \leq \theta_n \leq 180^\circ.$$

- Any direction cosine angle greater than 90° indicates a negative component along that respective axis. Spatially this is because all direction cosine angles are measured from the positive side of each axis. Mathematically this is because the cosine of any angle between 90 and 180 degrees is numerically negative.

Example 2.4.5 Direction Cosine Angles.

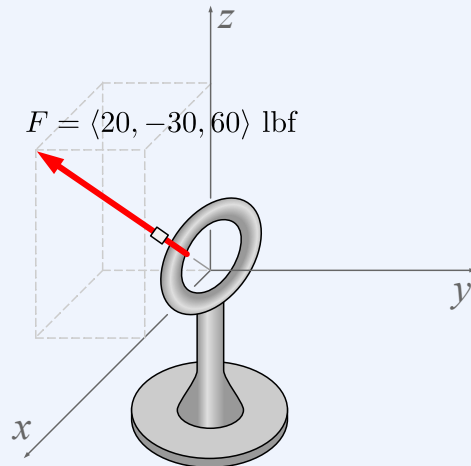

A rope pulls on an anchor ring centered at the origin with force $\mathbf{F} = \langle 20, -30, 60 \rangle$ lbf.

Find the magnitude of \mathbf{F} and the direction cosine angles, θ_x , θ_y , and θ_z components.

Solution. Since the three components of F are perpendicular, we can apply the Pythagorean Theorem to find the magnitude of F .

$$\begin{aligned} F = |\mathbf{F}| &= \sqrt{F_x^2 + F_y^2 + F_z^2} \\ &= \sqrt{20^2 + (-30)^2 + 60^2} \text{ lbf} \\ &= 70 \text{ lbf} \end{aligned}$$

Direction cosine angles are equal to the inverse cosine of each Cartesian force component divided by the force magnitude.

$$\theta_x = \cos^{-1} \left(\frac{F_x}{|\mathbf{F}|} \right) = \cos^{-1} \left(\frac{20}{70} \right) = 73.4^\circ$$

$$\theta_y = \cos^{-1} \left(\frac{F_y}{|\mathbf{F}|} \right) = \cos^{-1} \left(\frac{-30}{70} \right) = 115.38^\circ$$

$$\theta_z = \cos^{-1} \left(\frac{F_z}{|\mathbf{F}|} \right) = \cos^{-1} \left(\frac{60}{70} \right) = 31.0^\circ$$

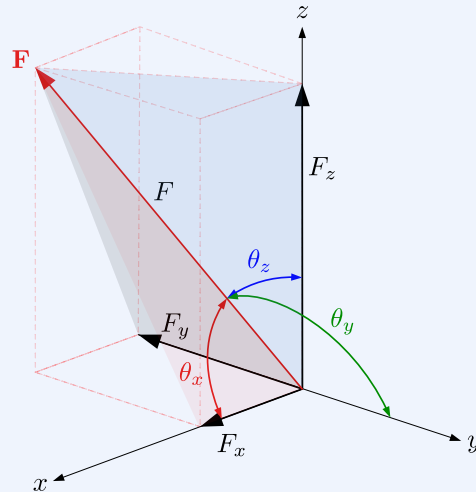

Since the direction cosine angles are measured from the positive x , y , and z axes, the negative component of F_y means that $\theta_y > 90^\circ$, while both θ_x and θ_z are less than 90° as their components are positive.

2.4.3 Spherical Coordinates

In spherical coordinates, points are specified with these three coordinates

- r , the **radial distance** from the origin to the point in space. This can also be thought of as the magnitude of a position vector \mathbf{r} pointing from the origin to the point in space.
- θ , the **azimuthal angle**, measured counter-clockwise from the positive x axis to the projection of the vector onto the xy plane, and
- ϕ , the **polar angle** from the z axis to the vector.

Other vectors are specified similarly by using the magnitude of the vector to define the radius of the sphere in appropriate units.

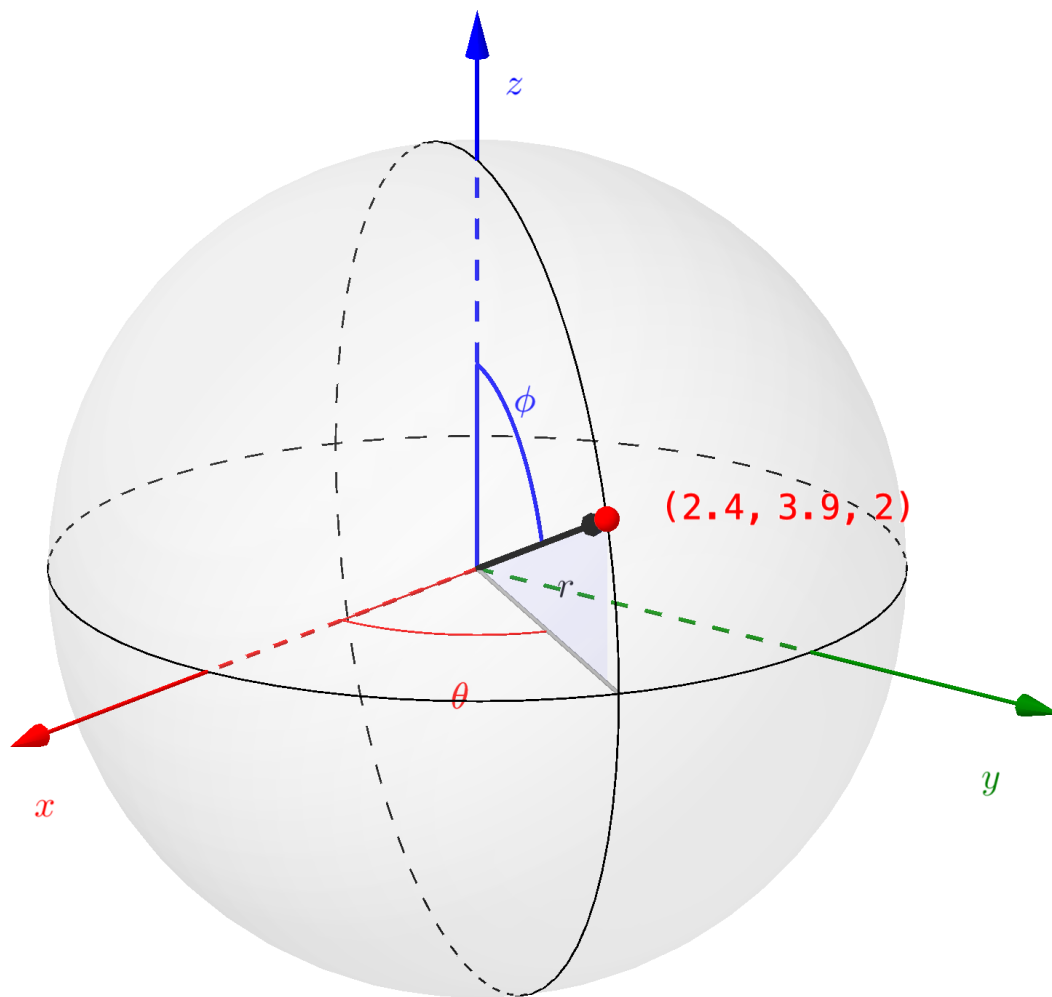

[Live Link](#)

Figure 2.4.6 Spherical Coordinate System

Question 2.4.7

What are the differences between polar coordinates and terrestrial latitude/longitude locations?

Answer. In terrestrial measurements

- Coordinate r is not needed since all points are on the surface of the globe.
- Longitude is measured 0° to 180° East or West of the prime meridian, rather than 0° to 360° counter-clockwise from the x axis.

- Latitude is measured 0° to 90° North or South of the equator, whereas polar angle ϕ is 0° to 180° measured from the “North Pole”.

When the two given spherical angles are defined in the manner shown here, the rectangular components of the vector $\mathbf{A} = (A ; \theta ; \phi)$ are found thus:

$$A' = A \sin \phi \quad (2.4.2)$$

$$A_z = A \cos \phi \quad (2.4.3)$$

$$A_x = A' \cos \theta = A \sin \phi \cos \theta \quad (2.4.4)$$

$$A_y = A' \sin \theta = A \sin \phi \sin \theta \quad (2.4.5)$$

Reflect on the equations above. Can you think through the process of how they were derived? The generalized steps are as follows. First, draw an accurate sketch of the given information and define the right triangles related to both θ and ϕ . Then use trig identities on the right triangle involving the vector, the z axis and angle ϕ to find A_z , and A' , the projection of \mathbf{A} onto the xy plane. Finally, use trig identities on the right triangle involving vector \mathbf{A}' and θ to find the remaining components of \mathbf{A} .

Example 2.4.8 Spherical Coordinates.

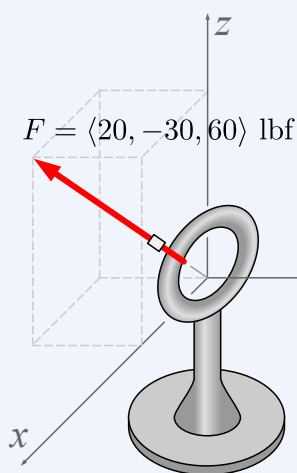

A rope pulls on an anchor ring centered at the origin with force $\mathbf{F} = \langle 20, -30, 60 \rangle$ lbf.

Find the *spherical* coordinates of \mathbf{F} .

Solution. To represent \mathbf{F} in spherical coordinates, we must find the radial distance r , the azimuthal angle θ , and the polar angle ϕ . Coordinate r is simply the magnitude of force \mathbf{F} . Since the three components of \mathbf{F} are perpendicular, we can apply the Pythagorean Theorem to find it.

$$\begin{aligned} F = |\mathbf{F}| = r &= \sqrt{F_x^2 + F_y^2 + F_z^2} \\ &= \sqrt{20^2 + (-30)^2 + 60^2} \text{ lbf} \end{aligned}$$

$$= 70 \text{ lbf}$$

Azimuthal angle θ measures the angle between the x axis and the projection of \mathbf{F} onto the xy plane, F_{xy} .

Using a right triangle with sides F_x , F_y , and F_{xy} , we can find θ using the inverse tangent of the ratio of the opposite to adjacent sides.

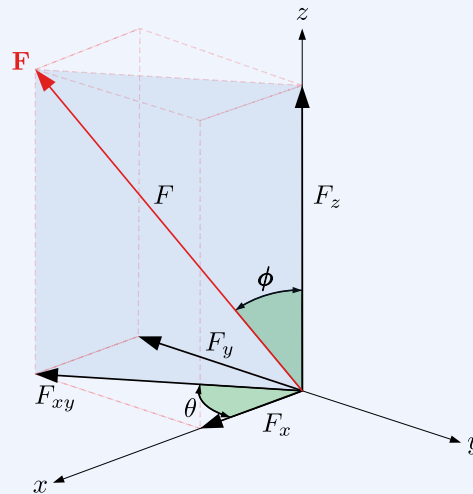

$$\theta = \tan^{-1} \frac{F_y}{F_x} = \tan^{-1} \left(\frac{-30}{20} \right) = -56.31^\circ$$

This angle is negative because it is measured *clockwise* from the positive x axis, opposite the standard CCW direction.

The polar angle ϕ is measured down from the $+z$ axis to the vector \mathbf{F} . We can find it using a right triangle with sides F , F_z , and F_{xy} . Note that ϕ is the same as the direction cosine angle θ_z .

$$\phi = \theta_z = \cos^{-1} \frac{F_z}{|\mathbf{F}|} = \cos^{-1} \left(\frac{60}{70} \right) = 31.0^\circ$$

Also notice that the azimuthal angle θ is smaller than the direction cosine angle θ_x , since θ is in the xy plane, but θ_x is a 3D angle from the x axis to the vector \mathbf{F} .

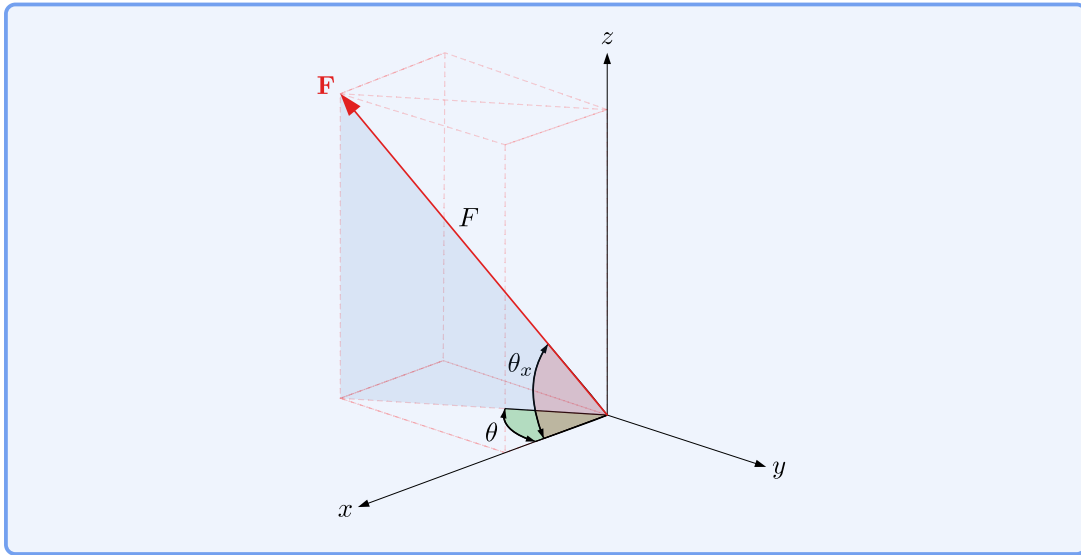

2.4.4 Cylindrical Coordinates

The cylindrical coordinate system is seldom used in statics, however, it is useful in certain geometries. Cylindrical coordinates extend two-dimensional polar coordinates by adding a z coordinate indicating the distance above or below the xy plane.

Points and vectors are specified with these three cylindrical coordinates.

- r , the radius of the cylinder. This is the distance from the origin to the projection of the tip of the vector onto the xy plane, or equivalently the magnitude of the component of the vector in the $x-y$ plane.
- θ , the azimuthal angle, measured counter-clockwise from the positive x axis to the projection of the vector onto the xy plane
- z , the vertical height of the vector tip, or equivalently the magnitude of the z component.

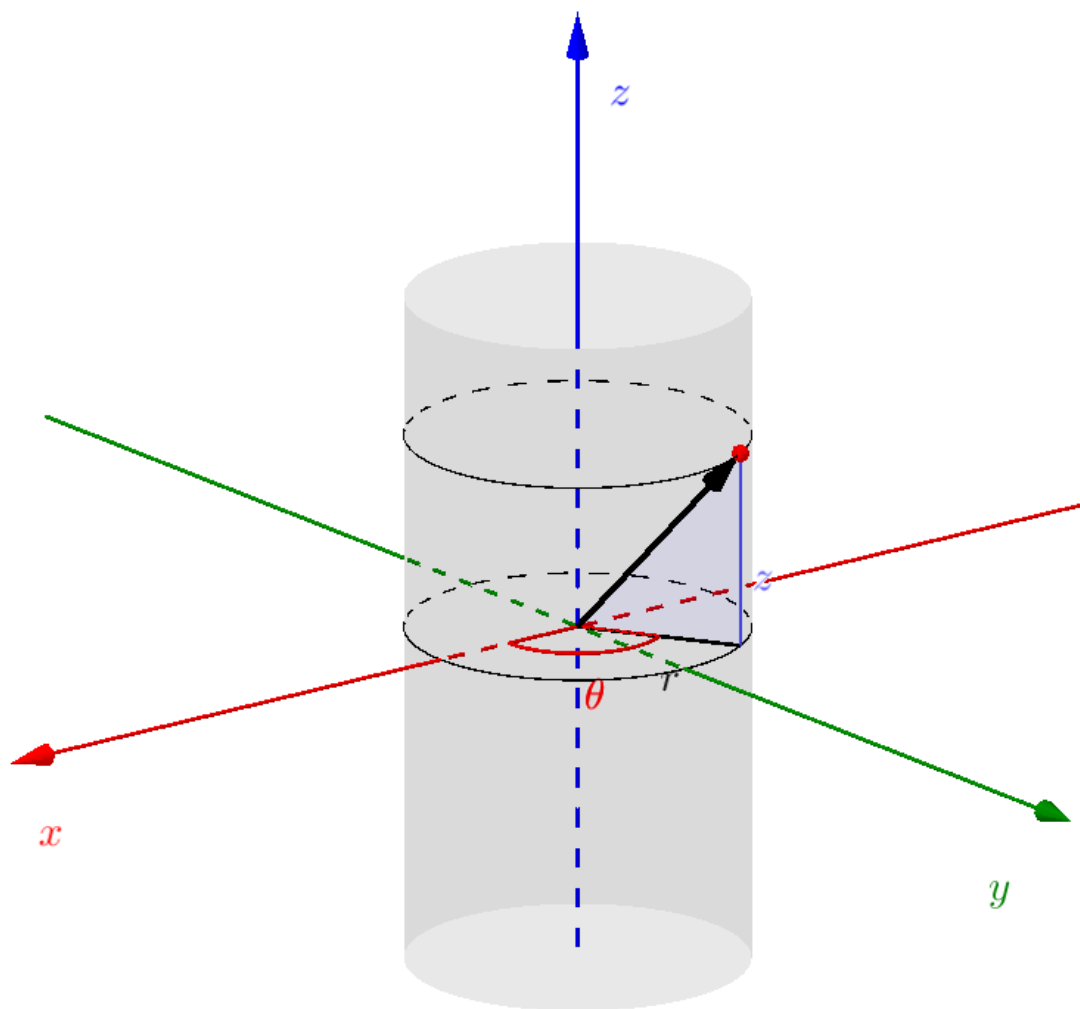

[Live Link](#)

Figure 2.4.9 Cylindrical Coordinate System

Unfortunately, not all problems give the angles θ and ϕ as defined here; so you will need to find them from the given angles in other situations.

You can use the interactive diagram in this section to practice visualizing and finding the components of a vector in all of these coordinate systems. You should be able to find the x , y , and z coordinates given direction angles, spherical or cylindrical coordinates, and vice-versa.

Example 2.4.10 Cylindrical Coordinates.

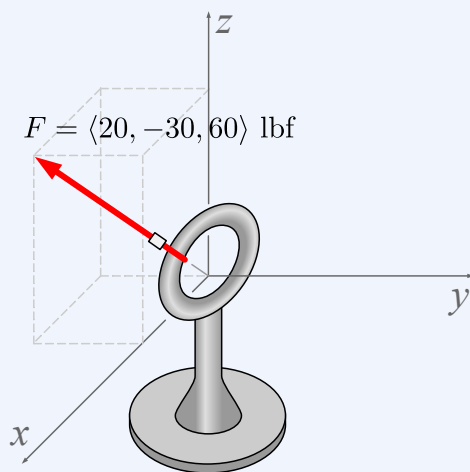

A rope pulls on an anchor ring centered at the origin with force $\mathbf{F} = \langle 20, -30, 60 \rangle$ lbf.

Find the *cylindrical* coordinates of \mathbf{F} .

Solution. To represent \mathbf{F} in cylindrical coordinates, we must find the radial distance, r , the azimuthal angle, θ , and the axial coordinate, z . In cylindrical coordinates, r is the radius of the cylinder rather than the radius of the enclosing sphere. r is the projection of \mathbf{F} onto the xy plane, F_{xy} , and can be found by applying the Pythagorean Theorem to the x and y components of \mathbf{F} .

$$\begin{aligned} r = F_{xy} &= \sqrt{F_x^2 + F_y^2} \\ &= \sqrt{20^2 + (-30)^2} \text{ lbf} \\ &= 36.06 \text{ lbf} \end{aligned}$$

The azimuthal angle θ is the same in both cylindrical and spherical coordinates. It measures the angle between the x axis and the projection of \mathbf{F} onto the xy plane. θ can be found using a right triangle in the xy plane with sides F_x and F_y .

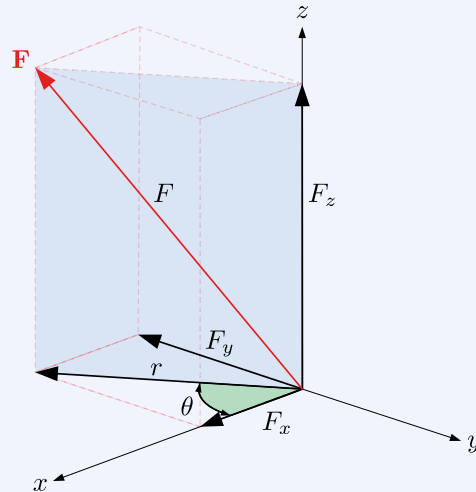

$$\theta = \tan^{-1} \frac{F_y}{F_x} = \tan^{-1} \left(\frac{-30}{20} \right) = -56.31^\circ$$

Finally, the z component is the vertical component of the force, F_z , which was given.

$$F_z = 60.0 \text{ lbf}$$

2.5 Unit Vectors

Key Questions

- Why are unit vectors useful?
- What are the unit vectors along the Cartesian x , y , and z axes?
- How do you find the force vector components of known force magnitude along a geometric line?
- How can you find unit vector components from direction cosine angles?

A unit vector is a vector with a magnitude of one and no units. As such, a unit vector represents a pure direction. By convention, a unit vector is indicated by a *hat* over a vector symbol. This may sound like a new concept, but it's a simple one, directly related to the unit circle, the Pythagorean Theorem, and the definitions of sine and cosine.

2.5.1 Cartesian Unit Vectors

A unit vector can point in any direction, but because they occur so frequently the unit vectors in each of the three Cartesian coordinate directions are given their own symbols, which are:

- **i**, for the unit vector pointing in the x direction,
- **j**, for the unit vector pointing in the y direction, and
- **k**, for the unit vector pointing in the z direction..

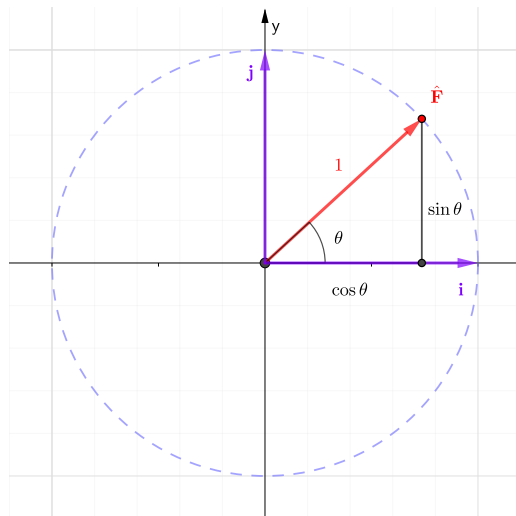

Live
Link

Figure 2.5.1 Unit Vector Interactive

Applying the Pythagorean Theorem to the triangle gives the equation for a unit circle

$$\cos^2 \theta + \sin^2 \theta = 1^2$$

No matter what angle a unit vector makes with the x axis, $\cos \theta$ and $\sin \theta$ are its scalar components. This relation assumes that the angle θ is measured from the x axis, if it is measured from the y axis the sine and cosine functions reverse, with $\sin \theta$ defining the horizontal component and the $\cos \theta$ defining the vertical component.

The x and y components of a point on the unit circle are also the scalar components of $\hat{\mathbf{F}}$, so

$$\left. \begin{array}{l} F_x = \cos \theta \\ F_y = \sin \theta \end{array} \right\} \implies \hat{\mathbf{F}} = \langle \cos \theta, \sin \theta \rangle.$$

2.5.2 Relation between Vectors and Unit Vectors

When a purely-directional unit vector is multiplied by a scalar value it is *scaled* by that amount. For example, when a unit vector pointing to the right is multiplied by 100 N the result is a 100 N vector pointing to the right. When a unit vector pointing up is multiplied by -50 N, the negative magnitude flips the direction of the unit vector and the result is a 50 N vector pointing down.

In general,

$$\mathbf{F} = |\mathbf{F}| \hat{\mathbf{F}}, \quad (2.5.1)$$

where $|\mathbf{F}|$ is the magnitude of vector \mathbf{F} , and $\hat{\mathbf{F}}$ is the unit vector pointing in the direction of \mathbf{F} .

Solving equation (2.5.1) for $\hat{\mathbf{F}}$ gives the approach to find the unit vector of known vector \mathbf{F} .

The process is straightforward— divide the vector by its magnitude.

$$\hat{\mathbf{F}} = \frac{\mathbf{F}}{|\mathbf{F}|} \quad (2.5.2)$$

To emphasize that unit vectors are pure direction, recall that vectors consist of both a magnitude and direction, so when we divide a vector by its own magnitude we are just left with direction.

$$\text{unit vector} = \frac{\mathbf{F}}{|\mathbf{F}|} = \frac{[\text{vector}]}{[\text{magnitude}]} = \frac{[\cancel{\text{magnitude}}] \cdot [\text{direction}]}{[\cancel{\text{magnitude}}]} = [\text{direction}]$$

This interactive shows vector \mathbf{F} , its associated unit vector $\hat{\mathbf{F}}$, and expressions for \mathbf{F} in terms of its unit vector $\hat{\mathbf{F}}$.

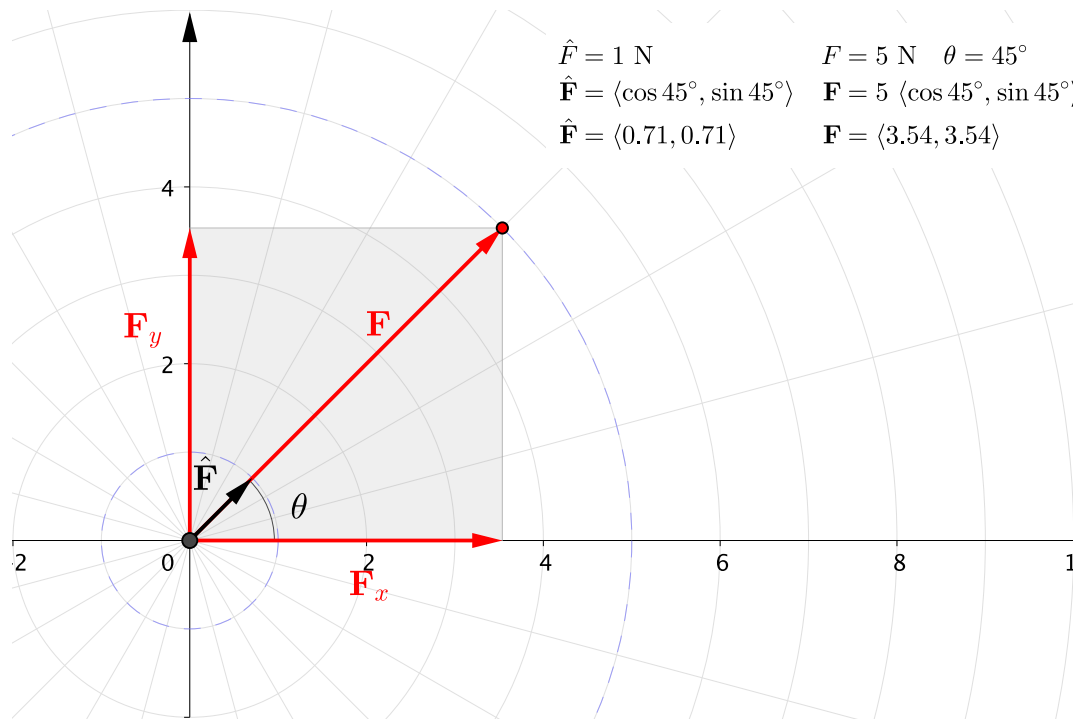

[Live Link](#)

Figure 2.5.2 Unit Vectors

Example 2.5.3 Find unit vector of a force.

Find the unit vector corresponding to a 100 N force at 60° above the positive x -axis.

Solution. In polar coordinates, the unit vector is a vector of magnitude 1, pointing in the same direction as the force, so, by inspection

$$\mathbf{F} = (100 \text{ N}; 60^\circ)$$

$$\hat{\mathbf{F}} = (1; 60^\circ)$$

In rectangular coordinates, first express \mathbf{F} in terms of its x and y components.

$$\left. \begin{array}{l} F_x = F \cos 60^\circ \\ F_y = F \sin 60^\circ \end{array} \right\} \implies \mathbf{F} = \langle F \cos 60^\circ, F \sin 60^\circ \rangle.$$

$$\hat{\mathbf{F}} = \frac{\mathbf{F}}{F} = \frac{\langle 100 \text{ N} \cos 60^\circ, 100 \text{ N} \sin 60^\circ \rangle}{100 \text{ N}} = \langle \cos 60^\circ, \sin 60^\circ \rangle$$

2.5.3 Force Vectors from Position Vectors

Unit vectors are generally the best approach when working with forces and distances in three dimensions.

For example, when the locations of two points on the line of action of a force are known, the unit vector of the line of action can be found and used to determine the components of the force acting along that line. This can be accomplished as follows, where A and B are points on the line of action.

1. Use the problem geometry to find \mathbf{AB} , the displacement vector from point A to point B .

You can either subtract the coordinates of the starting point A from the coordinates of the destination point B ,

$$\begin{aligned} A &= (A_x, A_y, A_z) \\ B &= (B_x, B_y, B_z) \\ \mathbf{AB} &= (B_x - A_x)\mathbf{i} + (B_y - A_y)\mathbf{j} + (B_z - A_z)\mathbf{k}, \text{ or} \end{aligned}$$

or, write the displacements directly by noting the change in the x , y , and z coordinates when moving from A to B .

$$\begin{aligned} AB_x &= \Delta x = B_x - A_x \\ AB_y &= \Delta y = B_y - A_y \\ AB_z &= \Delta z = B_z - A_z \\ \mathbf{AB} &= AB_x \mathbf{i} + AB_y \mathbf{j} + AB_z \mathbf{k} \end{aligned}$$

The result is the same with either method.

2. Find the distance between point A and point B using the Pythagorean Theorem. This distance is also the magnitude of \mathbf{AB} or $|\mathbf{AB}|$.

$$|\mathbf{AB}| = \sqrt{(AB_x)^2 + (AB_y)^2 + (AB_z)^2}$$

3. Find $\widehat{\mathbf{AB}}$, the unit vector from A to B , by dividing vector \mathbf{AB} by its magnitude. This is a unitless vector with a magnitude of 1 which points from A to B .

$$\widehat{\mathbf{AB}} = \left\langle \frac{AB_x}{|\mathbf{AB}|}, \frac{AB_y}{|\mathbf{AB}|}, \frac{AB_z}{|\mathbf{AB}|} \right\rangle$$

4. Finally, multiply the magnitude of the force by the unit vector $\widehat{\mathbf{AB}}$ to get force \mathbf{F}_{AB} .

$$\begin{aligned} \mathbf{F}_{AB} &= F_{AB} \widehat{\mathbf{AB}} \\ &= F_{AB} \left\langle \frac{AB_x}{|\mathbf{AB}|}, \frac{AB_y}{|\mathbf{AB}|}, \frac{AB_z}{|\mathbf{AB}|} \right\rangle \end{aligned}$$

The interactive below can be used to visualize the displacement vector and its unit vector, and practice this procedure.

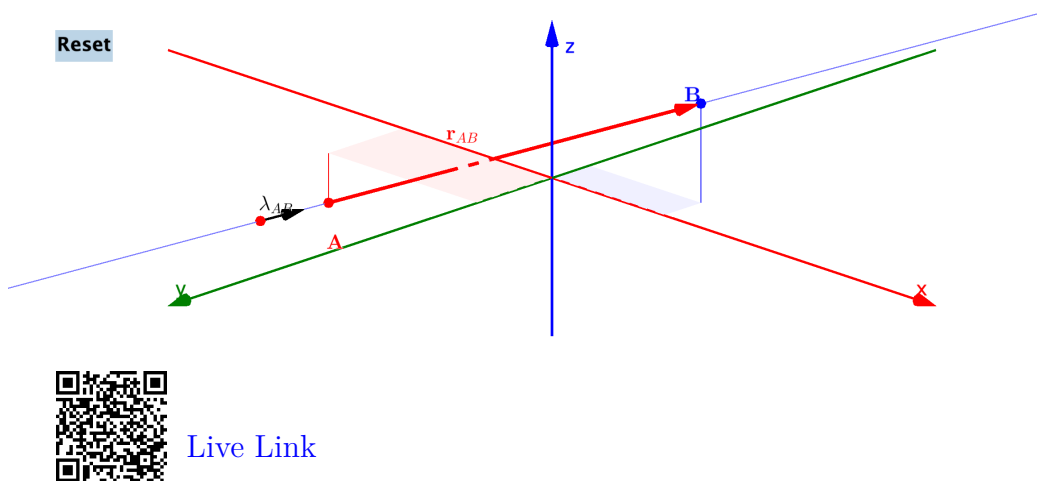

Figure 2.5.4 Unit Vectors in Space

Example 2.5.5 Component in a Specified Direction.

Determine the components of a 5 kN force \mathbf{F} acting at point A , in the direction of a line from A to B . Given: $A = (2, 3, -2.1)$ m and $B = (-2.5, 1.5, 2.2)$ m

We will take the solution one step at a time.

- (a) Draw a good diagram.

Hint. The interactive in Figure 2.5.4 may be useful for this problem.

- (b) Find the displacement vector from A to B .

Answer.

$$\mathbf{AB} = \langle -4.5, -1.5, 4.3 \rangle \text{ m}$$

Solution.

$$\begin{aligned} \mathbf{AB} &= (B_x - A_x)\mathbf{i} + (B_y - A_y)\mathbf{j} + (B_z - A_z)\mathbf{k} \\ &= [(-2.5 - 2)\mathbf{i} + (1.5 - 3)\mathbf{j} + (2.2 - (-2.1))\mathbf{k}] \text{ m} \\ &= (-4.5\mathbf{i} - 1.5\mathbf{j} + 4.3\mathbf{k}) \text{ m} \\ &= \langle -4.5, -1.5, 4.3 \rangle \text{ m} \end{aligned}$$

- (c) Find the magnitude of the displacement vector.

Answer.

$$|\mathbf{AB}| = 6.402 \text{ m}$$

Solution.

$$\begin{aligned} |\mathbf{AB}| &= \sqrt{(\Delta_x)^2 + (\Delta_y)^2 + (\Delta_z)^2} \\ &= \sqrt{(-4.5)^2 + (-1.5)^2 + 4.3^2} \text{ m} \\ &= \sqrt{40.99} \text{ m} \\ &= 6.402 \text{ m} \end{aligned}$$

(d) Find the unit vector pointing from A to B .

Answer.

$$\widehat{\mathbf{AB}} = \langle -0.7, -0.23, 0.67 \rangle$$

Solution.

$$\begin{aligned} \widehat{\mathbf{AB}} &= \left\langle \frac{\Delta_x}{|\mathbf{AB}|}, \frac{\Delta_y}{|\mathbf{AB}|}, \frac{\Delta_z}{|\mathbf{AB}|} \right\rangle \\ &= \left\langle \frac{-4.5}{6.402}, \frac{-1.5}{6.402}, \frac{4.3}{6.402} \right\rangle \\ \widehat{\mathbf{AB}} &= \langle -0.7, -0.23, 0.67 \rangle \end{aligned}$$

(e) Find the force vector.

Answer.

$$\mathbf{F}_{AB} = \langle -3.51, -1.17, 3.36 \rangle \text{ kN}$$

Solution.

$$\begin{aligned} \mathbf{F}_{AB} &= F_{AB} \widehat{\mathbf{AB}} \\ &= 5 \text{ kN} \langle -0.7, -0.23, 0.67 \rangle \\ &= \langle -3.51, -1.17, 3.36 \rangle \text{ kN} \end{aligned}$$

Given the properties of unit vectors, there are some conceptual checks you can make after computing unit vector components which can prevent subsequent errors.

- The signs of unit vector components need to match the signs of the original position vector. A unit vector has the same line of action and sense as the

position vector but is scaled down to one unit in magnitude.

- Components of a unit vector must be between -1 and 1. If the magnitude of a unit vector is one, then it is impossible for it to have rectangular components larger than one.

2.5.4 Unit Vectors and Direction Cosines

If you look closely at the right side of equation (2.4.1), you will see that each equation consists of a component divided by the total vector magnitude. These are the same equations just used to find unit vectors. Thus, the cosine of each direction cosine angle collectively also computes the components of the unit vector; hence we can write an equation for $\hat{\mathbf{A}}$, i.e., the unit vector along \mathbf{A} .

$$\hat{\mathbf{A}} = \cos \theta_x \mathbf{i} + \cos \theta_y \mathbf{j} + \cos \theta_z \mathbf{k}$$

Combining the Pythagorean Theorem with our knowledge of unit vectors and direction cosine angles gives this result: if you know two of the three direction cosine angles you can manipulate the following equation to find the third.

$$\cos^2 \theta_x + \cos^2 \theta_y + \cos^2 \theta_z = 1 \quad (2.5.3)$$

2.6 Vector Addition

Key Questions

- How do you set up vectors for graphical addition using the Triangle Rule?
- Does it matter which vector you start with when using the Triangle Rule?
- Why can you separate a two-dimensional vector equation into two independent equations to solve for up to two unknowns?
- If you and another student define vectors using different direction coordinate systems, will you end up with the same resultant vector?
- What is the preferred technique to add vectors in three-dimensional systems?

In this section we will look at several different methods of vector addition. Vectors being added together are called the **components**, and the sum of the components is called the **resultant vector**.

These different methods are tools for your statics toolbox. They give you multiple different ways to think about vector addition and to approach a problem. Your goal should be to learn to use them all and to identify which approach will be the easiest to use in a given situation.

2.6.1 Triangle Rule of Vector Addition

All methods of vector addition are ultimately based on the tip-to-tail method discussed in a one-dimensional context in [Subsection 2.2.1](#). There are two ways to draw or visualize adding vectors in two or three dimensions, the **Triangle Rule** and **Parallelogram Rule**. Both are equivalent.

- *Triangle Rule.*

Place the tail of one vector at the tip of the other vector, then draw the resultant from the first vector's tail to the final vector's tip.

- *Parallelogram Rule.*

Place both vectors' tails at the origin, then complete a parallelogram with lines parallel to each vector through the tip of the other. The resultant is equal to the diagonal from the tails to the opposite corner.

The interactive below shows two forces **A** and **B** pulling on a particle at the origin, and the appropriate diagram for the triangle or parallelogram rule. Both approaches produce the same resultant force **R** as expected.

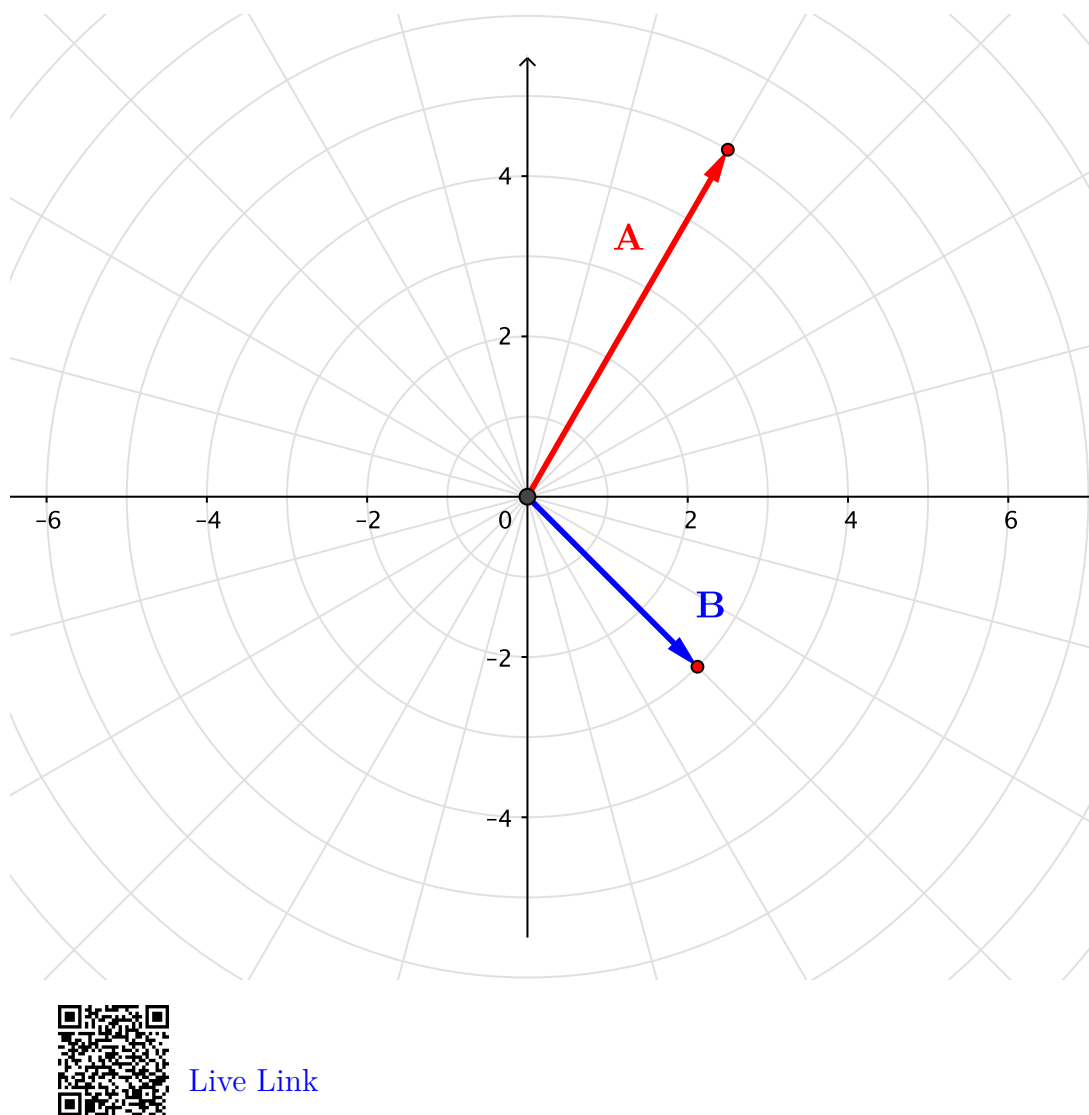

Figure 2.6.1 Vector Addition Methods

2.6.2 Graphical Vector Addition

Graphical vector addition involves drawing a scaled diagram using either the parallelogram or triangle rule, and then measuring the magnitudes and directions from the diagram. Graphical solutions work well enough for two-dimensional problems where all the vectors live in the same plane and can be drawn on a sheet of paper, but are not very useful for three-dimensional problems unless you use technology.

If you carefully draw the triangle accurately to scale and use a protractor and ruler you can measure the magnitude and direction of the resultant. However, your answer will only be as precise as your diagram and your ability to read your tools. If you use technology such as GeoGebra or a CAD program to make the diagram, your answer will be precise. The interactive in [Figure 2.6.1](#) may be

useful for this.

Even though the graphical approach has limitations, it is worth your attention because it provides a good way to visualize the effects of multiple forces, to quickly estimate ballpark answers, and to visualize the diagrams you need to use alternate methods to follow.

2.6.3 Trigonometric Vector Addition

You *can* get a precise answer from the triangle or parallelogram rule by

1. drawing a quick diagram using either rule,
2. identifying three known sides or angles,
3. using trigonometry to solve for the unknown sides and angles.

The trigonometric tools you will need are found in [Appendix B](#).

Using triangle-based geometry to solve vector problems is a quick and powerful tool, but includes the following limitations:

- There are only three sides in a triangle; thus vectors can only be added two at a time. If you need to add three or more vectors using this method, you must add the first two, then add the third to that sum and so on.
- If you fail to draw the correct vector triangle or identify the known sides and angles, you will not find the correct answer.
- The trigonometric functions produce scalar values. You can use them to find the magnitudes the angles between vectors, but the results are not, by themselves, vectors.

When you need to find the resultant of more than two vectors, it is generally best to use the algebraic methods described below.

2.6.4 Orthogonal Components

Any arbitrary two-dimensional vector \mathbf{F} can be broken into two component vectors which are the sides of a parallelogram having \mathbf{F} as its diagonal. The process of finding components of a vector in particular directions is called **vector resolution**. While a vector can be resolved into components in any two directions, it's generally most useful to resolve them into **rectangular** or **orthogonal** components, where the parallelogram is a rectangle and the components are perpendicular.

There are an infinite number of possible rectangles to choose from, so each vector has an infinite number of sets of orthogonal components. However, the most important set occurs when the sides of the rectangle are parallel to the x

and y axes. These orthogonal components are given x and y subscripts indicate that they're aligned with the coordinate axes. For vector \mathbf{F} ,

$$\mathbf{F} = \mathbf{F}_x + \mathbf{F}_y = F_x \mathbf{i} + F_y \mathbf{j}, \quad (2.6.1)$$

where F_x and F_y are the scalar components of \mathbf{F} . The advantage of this choice of components is that vector calculations can be replaced with ordinary algebraic calculation on scalar values for each orthogonal direction.

Alternately, you may rotate the coordinate system to any other convenient angle, and find the components in the directions of the rotated coordinate axes x' and y' . In either case, the vector is the sum of the rectangular components

$$\mathbf{F} = \mathbf{F}_x + \mathbf{F}_y = \mathbf{F}_{x'} + \mathbf{F}_{y'}. \quad (2.6.2)$$

The interactive below can help you visualize the relationship between a vector and its components in both the x - y and x' - y' directions.

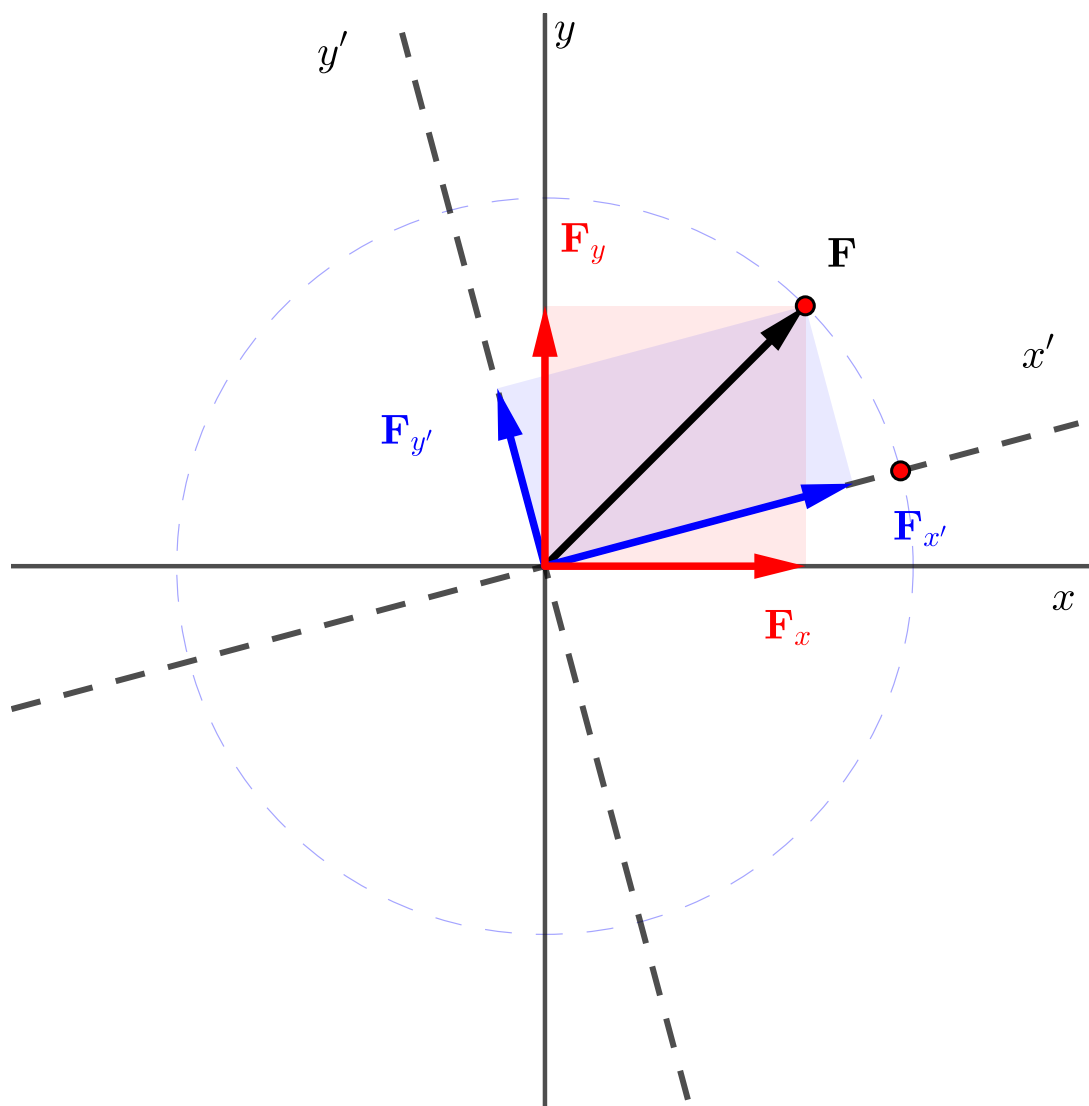

[Live Link](#)

Figure 2.6.2 Orthogonal Components

2.6.5 Algebraic Addition of Components

While the parallelogram rule and the graphical and trigonometric methods are useful tools for visualizing and finding the sum of two vectors, they are not particularly suited for adding *more* than two vectors or working in three dimensions.

Consider vector \mathbf{R} which is the sum of several vectors \mathbf{A} , \mathbf{B} , \mathbf{C} and perhaps more. Vectors \mathbf{A} , \mathbf{B} and \mathbf{C} are the components of \mathbf{R} , and the \mathbf{R} is the resultant of \mathbf{A} , \mathbf{B} and \mathbf{C} .

It is easy enough to say that $\mathbf{R} = \mathbf{A} + \mathbf{B} + \mathbf{C}$, but how can we calculate \mathbf{R} ?

You could draw the vectors arranged tip-to-tail and then use the triangle rule to add the first two components, then use it again to add the third component to that sum, and so forth until all the components have been added. The final sum is the resultant, \mathbf{R} . The process gets progressively more tedious the more components there are to sum.

This section introduces an alternate method to add multiple vectors which is straightforward, efficient and robust. This is called *algebraic method*, because the vector addition is replaced with a process of *algebraic* addition of *scalar* components. The algebraic technique works equally well for two and three-dimensional vectors, and for summing any number of vectors.

To find the sum of multiple vectors using the algebraic method:

1. Find the scalar components of each component vector in the x and y directions using the P to R procedure described in [Subsection 2.3.3](#).
2. Algebraically sum the scalar components in each coordinate direction. The scalar components will be positive if they point right or up, negative if they point left or down. These sums are the scalar components of the resultant.
3. Resolve the resultant's components to find the magnitude and direction of the resultant vector using the R to P procedure described in [Subsection 2.3.3](#).

The resultant \mathbf{F}_R is simply the algebraic sum of the components in each coordinate direction.

$$\mathbf{F}_R = \Sigma F_x \mathbf{i} + \Sigma F_y \mathbf{j} + \Sigma F_z \mathbf{k}$$

or in bracket notation

$$\mathbf{F}_R = \langle \Sigma F_x, \Sigma F_y, \Sigma F_z \rangle \quad (2.6.3)$$

This process is illustrated in the following interactive diagram and in the next example.

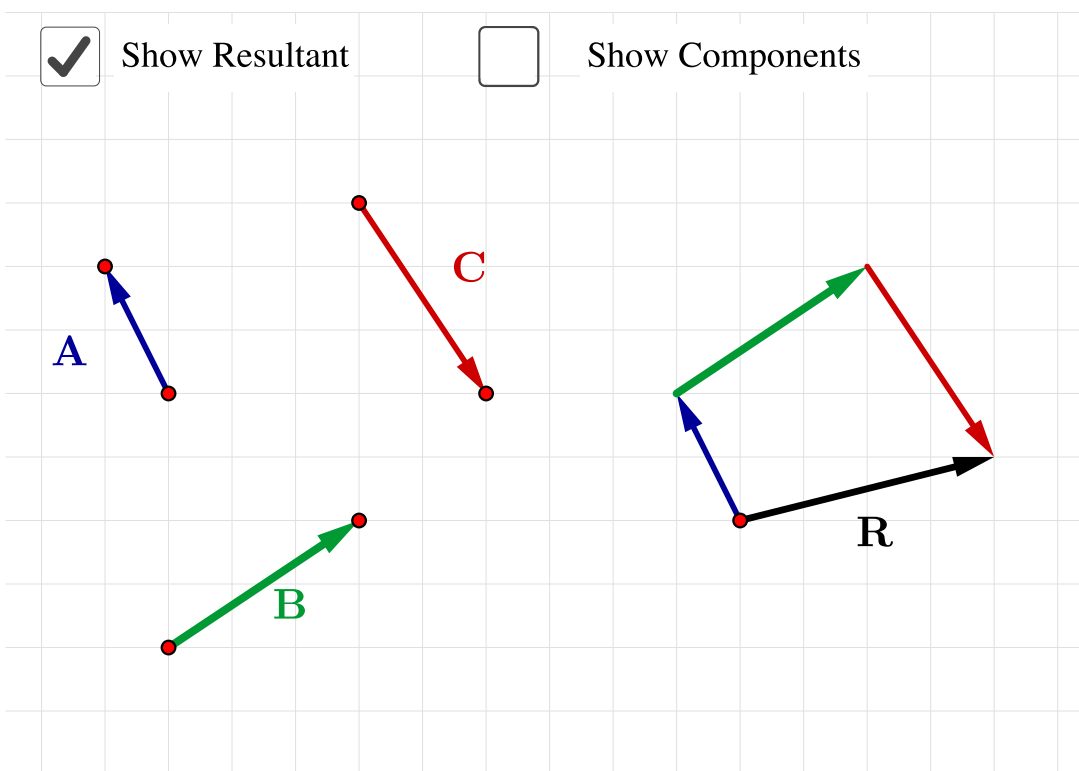

[Live Link](#)

Figure 2.6.3 Vector addition by summing rectangular components.

Example 2.6.4 Vector Addition.

Vector $\mathbf{A} = 200 \text{ N} \angle 45^\circ$ counter-clockwise from the x axis, and vector $\mathbf{B} = 300 \text{ N} \angle 70^\circ$ counter-clockwise from the y axis. Find the resultant $\mathbf{R} = \mathbf{A} + \mathbf{B}$ by addition of scalar components.

Solution.

Use the given information to draw a sketch of the situation. By imagining or sketching the parallelogram rule, it should be apparent that the resultant vector points up and to the left.

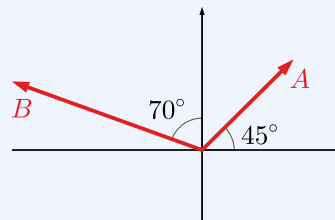

$$A_x = 200 \text{ N} \cos 45^\circ = 141.4 \text{ N} \quad B_x = -300 \text{ N} \sin 70^\circ = -281.9 \text{ N}$$

$$A_y = 200 \text{ N} \sin 45^\circ = 141.4 \text{ N} \quad B_y = 300 \text{ N} \cos 70^\circ = 102.6 \text{ N}$$

$$\begin{aligned}R_x &= A_x + B_x & R_y &= A_y + B_y \\ &= 141.4 \text{ N} - 281.9 \text{ N} & &= 141.4 \text{ N} + 102.6 \text{ N} \\ &= -140.5 \text{ N} & &= 244.0 \text{ N}\end{aligned}$$

$$R = \sqrt{R_x^2 + R_y^2} = 281.6 \text{ N} \quad \theta = \tan^{-1}\left(\frac{R_y}{R_x}\right) = -60.1^\circ$$

This answer indicates that the resultant points down and to the left, which is odd because the parallelogram rule shows that the resultant should point up and to the left.

This occurs because the calculator always returns angles in the first or fourth quadrant for \tan^{-1} . To get the actual direction of the resultant, add 180° to the calculator result.

$$\theta = -60.1^\circ + 180^\circ = 119.9^\circ$$

The final answer for the magnitude and direction of the resultant is

$$\mathbf{R} = 281.6 \text{ N} \angle 119.9^\circ$$

measured counter-clockwise from the x axis.

The process for adding three-dimensional vectors is exactly the same, except that the z component is included as well. This interactive allows you to input the three-dimensional vector components of forces \mathbf{A} and \mathbf{B} and view the resultant force \mathbf{R} which is the sum of \mathbf{A} and \mathbf{B} .

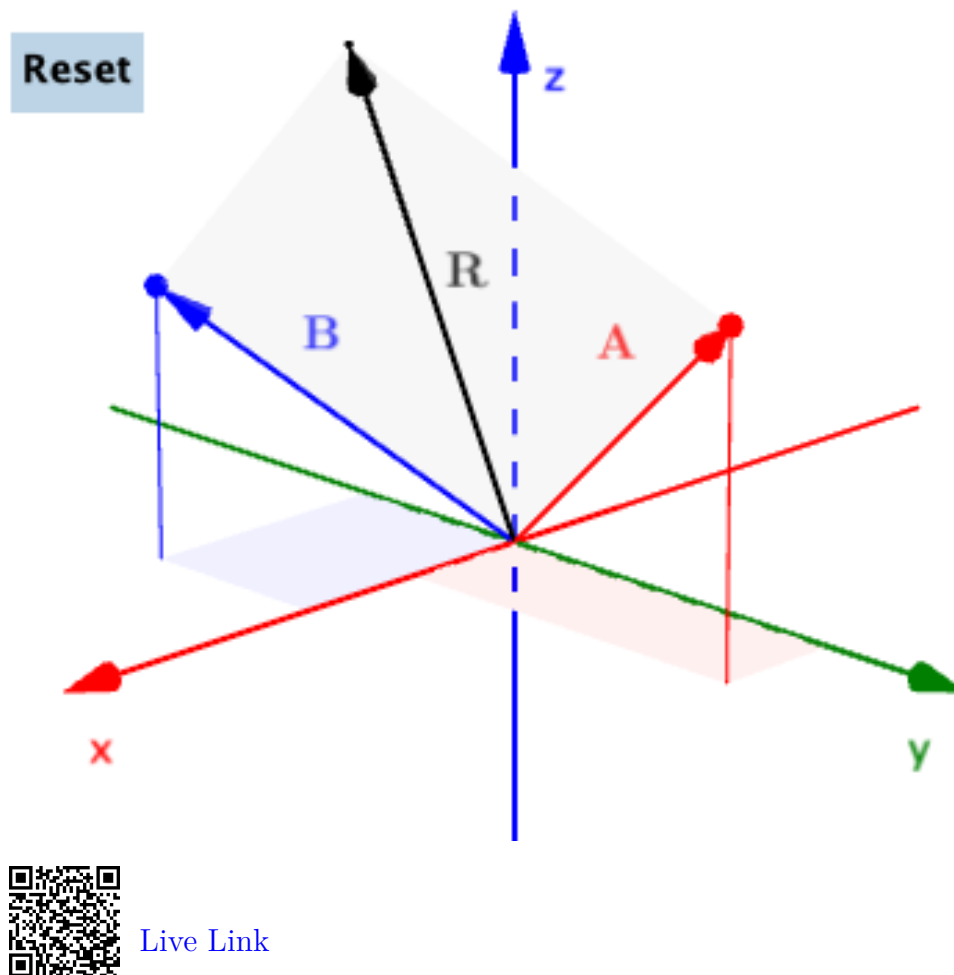

Figure 2.6.5 Vector Addition in Three Dimensions

2.6.6 Vector Subtraction

Like one-dimensional vector subtraction, the easiest way to handle two-dimensional vector subtraction is by taking the negative of a vector followed by vector addition. Multiplying a vector by -1 preserves its magnitude but flips its direction, which has the effect of changing the sign of the scalar components.

$$\mathbf{A} - \mathbf{B} = \mathbf{A} + (-\mathbf{B})$$

After negating the second vector you can choose any technique you prefer for vector addition.

2.7 Dot Products

Key Questions

- What are dot products used for?
- What does it mean when the dot product of two vectors is zero?
- How do you use a dot product to find the angle between two vectors?
- What does it mean when the scalar component of the projection $\|\text{proj}_{\mathbf{A}} \mathbf{B}\|$ is negative?

Unlike ordinary algebra where there is only one way to multiply numbers, there are two distinct vector multiplication operations: **dot product** and the **cross product**. Alternately, the first is referred to as the **scalar product** because its result is a scalar, and the second as the **vector product** because its result is a vector. The dot product and its applications will be discussed in this section and the cross product in the next.

2.7.1 Calculation of the Dot product

For two vectors $\mathbf{A} = \langle A_x, A_y, A_z \rangle$ and $\mathbf{B} = \langle B_x, B_y, B_z \rangle$, the dot product multiplication is computed by summing the products of the components.

$$\mathbf{A} \cdot \mathbf{B} = A_x B_x + A_y B_y + A_z B_z \quad (2.7.1)$$

It can be shown that an alternate, equivalent method to compute the dot product is

$$\mathbf{A} \cdot \mathbf{B} = |\mathbf{A}||\mathbf{B}| \cos \theta = A B \cos \theta \quad (2.7.2)$$

where θ in the equation is the angle between the two vectors and $|\mathbf{A}|$ and $|\mathbf{B}|$ are the magnitudes of \mathbf{A} and \mathbf{B} .

We can conclude from the second equation that the dot product of two perpendicular vectors is zero, because $\cos 90^\circ = 0$, and that the dot product of two parallel vectors equals the product of their magnitudes.

When dotting unit vectors that have a magnitude of one, the dot products of a unit vector with itself is one and the dot product two perpendicular unit vectors is zero, so for \mathbf{i} , \mathbf{j} , and \mathbf{k} we have

$$\begin{array}{lll} \mathbf{i} \cdot \mathbf{i} = 1 & \mathbf{j} \cdot \mathbf{i} = 0 & \mathbf{k} \cdot \mathbf{i} = 0 \\ \mathbf{i} \cdot \mathbf{j} = 0 & \mathbf{j} \cdot \mathbf{j} = 1 & \mathbf{k} \cdot \mathbf{j} = 0 \\ \mathbf{i} \cdot \mathbf{k} = 0 & \mathbf{j} \cdot \mathbf{k} = 0 & \mathbf{k} \cdot \mathbf{k} = 1 \end{array}$$

Dot products are commutative, associative and distributive:

1. **Commutative.** The order does not matter.

$$\mathbf{A} \cdot \mathbf{B} = \mathbf{B} \cdot \mathbf{A} \quad (2.7.3)$$

2. **Associative.** It does not matter whether you multiply a scalar value C by the final dot product, or either of the individual vectors, you will still get the same answer.

$$C(\mathbf{A} \cdot \mathbf{B}) = (C\mathbf{A}) \cdot \mathbf{B} = \mathbf{A} \cdot (C\mathbf{B}) \quad (2.7.4)$$

3. **Distributive.** If you are dotting one vector \mathbf{A} with the sum of two more ($\mathbf{B} + \mathbf{C}$), you can either add $\mathbf{B} + \mathbf{C}$ first, or dot \mathbf{A} by both and add the final value.

$$\mathbf{A} \cdot (\mathbf{B} + \mathbf{C}) = (\mathbf{A} \cdot \mathbf{B}) + (\mathbf{A} \cdot \mathbf{C}) \quad (2.7.5)$$

Dot products can be used to compute the magnitude of a vector, determine the angle between two vectors, and find the rectangular component or projection of a vector in a specified direction. These applications will be discussed in the following sections.

2.7.2 Magnitude of a Vector

Dot products can be used to find vector magnitudes. When a vector is dotted with itself using (2.7.1), the result is the square of the magnitude of the vector. (Recall that $|\mathbf{A}|$ and A are alternate notations for the magnitude of vector \mathbf{A} .)

$$\mathbf{A} \cdot \mathbf{A} = |\mathbf{A}|^2 = A^2. \quad (2.7.6)$$

The proof is trivial. By the definition of the dot product (2.7.1) and the Pythagorean theorem:

$$\begin{aligned} \mathbf{A} \cdot \mathbf{A} &= A_x A_x + A_y A_y \\ &= A_x^2 + A_y^2 = A^2 \\ &= |\mathbf{A}|^2 \end{aligned}$$

Taking the square root of each side gives the magnitude of \mathbf{A}

$$\sqrt{\mathbf{A} \cdot \mathbf{A}} = A = |\mathbf{A}|. \quad (2.7.7)$$

The result is similar for three-dimensional vectors.

Example 2.7.1 Find Vector Magnitude using the Dot Product.

Find the magnitude of vector \mathbf{F} with components $F_x = 30$ N, $F_y = -40$ N and $F_z = 50$ N

Solution.

$$\mathbf{F} = \langle 30 \text{ N}, -40 \text{ N}, 50 \text{ N} \rangle$$

$$\begin{aligned} \mathbf{F} \cdot \mathbf{F} &= F_x^2 + F_y^2 + F_z^2 \\ &= (30 \text{ N})^2 + (-40 \text{ N})^2 + (50 \text{ N})^2 \\ &= 5000 \text{ N}^2 \end{aligned}$$

$$\begin{aligned} F &= |\mathbf{F}| = \sqrt{\mathbf{F} \cdot \mathbf{F}} \\ &= \sqrt{5000 \text{ N}^2} \\ &= 70.7 \text{ N} \end{aligned}$$

2.7.3 Angle between Two Vectors

A second application of the dot product is to find the angle between two vectors. Equation (2.7.2) provides the procedure.

$$\begin{aligned} \mathbf{A} \cdot \mathbf{B} &= |\mathbf{A}||\mathbf{B}| \cos \theta \\ \cos \theta &= \frac{\mathbf{A} \cdot \mathbf{B}}{|\mathbf{A}||\mathbf{B}|} \end{aligned} \tag{2.7.8}$$

Example 2.7.2 Angle between Orthogonal Unit Vectors.

Find the angle between $\mathbf{i} = \langle 1, 0, 0 \rangle$ and $\mathbf{j} = \langle 0, 1, 0 \rangle$.

Solution.

$$\begin{aligned} \cos \theta &= \frac{\mathbf{i} \cdot \mathbf{j}}{|\mathbf{i}||\mathbf{j}|} \\ &= \frac{(1)(0) + (0)(1) + (0)(0)}{(1)(1)} \\ &= 0 \end{aligned}$$

$$\begin{aligned} \theta &= \cos^{-1}(0) \\ &= 90^\circ \end{aligned}$$

This shows that \mathbf{i} and \mathbf{j} are perpendicular to each other.

Example 2.7.3 Angle between Two Vectors.

Find the angle between $\mathbf{F} = \langle 100 \text{ N}, 200 \text{ N}, -50 \text{ N} \rangle$ and $\mathbf{G} = \langle -75 \text{ N}, 150 \text{ N}, -40 \text{ N} \rangle$.

Solution.

$$\begin{aligned} \cos \theta &= \frac{\mathbf{F} \cdot \mathbf{G}}{|\mathbf{F}||\mathbf{G}|} \\ &= \frac{F_x G_x + F_y G_y + F_z G_z}{\sqrt{F_x^2 + F_y^2 + F_z^2} \sqrt{G_x^2 + G_y^2 + G_z^2}} \\ &= \frac{(100)(-75) + (200)(150) + (-50)(-40)}{\sqrt{100^2 + 200^2 + (-50)^2} \sqrt{(-75)^2 + 150^2 + (-40)^2}} \\ &= \frac{24500}{(229.1)(172.4)} \\ &= 0.620 \\ \theta &= \cos^{-1}(0.620) \\ &= 51.7^\circ \end{aligned}$$

2.7.4 Vector Projection

The dot product is used to find the **projection** of one vector onto another. You can think of a projection of \mathbf{B} on \mathbf{A} as a vector the length of the shadow of \mathbf{B} on the line of action of \mathbf{A} when the sun is directly above \mathbf{A} . More precisely, the projection of \mathbf{B} onto \mathbf{A} produces the rectangular component of \mathbf{B} in the direction *parallel* to \mathbf{A} . This is one side of a rectangle aligned with \mathbf{A} , having \mathbf{B} as its diagonal.

This is illustrated in [Figure 2.7.4](#), where \mathbf{u} is the projection of \mathbf{B} onto \mathbf{A} , or alternately \mathbf{u} is the rectangular component of \mathbf{B} in the direction of \mathbf{A} .

In this text we will use the symbols

- $\text{proj}_{\mathbf{A}} \mathbf{B}$ to mean the **vector projection** of \mathbf{B} on \mathbf{A}
- $|\text{proj}_{\mathbf{A}} \mathbf{B}|$ to mean the *magnitude* of the vector projection, a positive or zero-valued scalar, and
- $\|\text{proj}_{\mathbf{A}} \mathbf{B}\|$ to mean the **scalar projection**. This value represents the component of \mathbf{B} in the \mathbf{A} direction, and can have a positive, zero, or negative value.

As we have mentioned before, the magnitude of a vector is its length and is always positive or zero, while a scalar component is a signed value that can be positive or negative. When a scalar component is multiplied by a unit vector

the result is a vector in that direction when the scalar component is positive, or 180° opposite when the scalar component is negative.

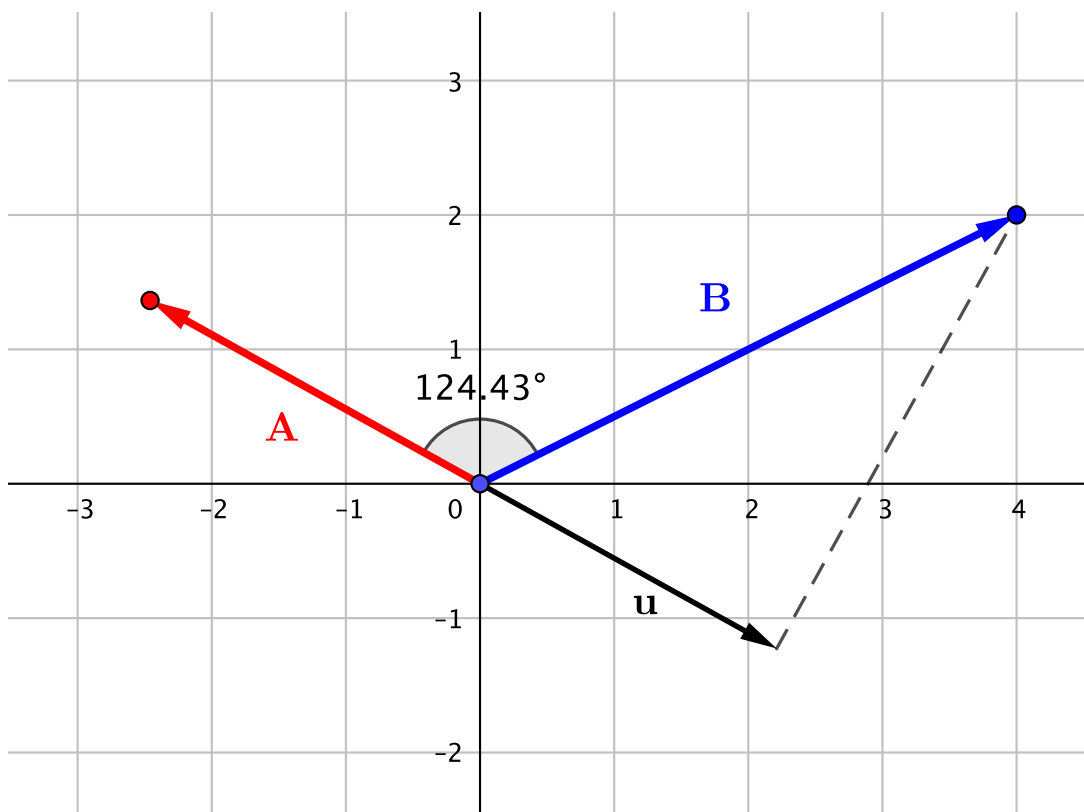

[Live Link](#)

Figure 2.7.4 Vector projection in two dimensions.

The interactive shows that the projection is the adjacent side of a right triangle with \mathbf{B} as the hypotenuse. From the definition of the dot product (2.7.2) we find that

$$\mathbf{A} \cdot \mathbf{B} = A(B \cos \theta) = A \|\text{proj}_{\mathbf{A}} \mathbf{B}\|, \quad (2.7.9)$$

where $B \cos \theta$ is the scalar component of the projection. So, the dot product of \mathbf{A} and \mathbf{B} gives us the projection of \mathbf{B} onto \mathbf{A} times the magnitude of \mathbf{A} . This value will be positive when $\theta < 90^\circ$, negative when $\theta > 90^\circ$, and zero when the vectors are perpendicular because of the properties of the cosine function.

So, to find the scalar value of the projection of \mathbf{B} onto \mathbf{A} we divide by the magnitude of \mathbf{A} .

$$\|\text{proj}_{\mathbf{A}} \mathbf{B}\| = \frac{\mathbf{A} \cdot \mathbf{B}}{A} = \frac{\mathbf{A}}{A} \cdot \mathbf{B} = \hat{\mathbf{A}} \cdot \mathbf{B} \quad (2.7.10)$$

where $\hat{\mathbf{A}} = \frac{\mathbf{A}}{A}$ is the unit vector in the direction of \mathbf{A} .

If you want the *vector* projection of \mathbf{B} onto \mathbf{A} , as opposed to the *scalar* projection we just found, multiply the *scalar* projection by the unit vector $\hat{\mathbf{A}}$.

$$\text{proj}_{\mathbf{A}} \mathbf{B} = \|\text{proj}_{\mathbf{A}} \mathbf{B}\| \hat{\mathbf{A}} = (\hat{\mathbf{A}} \cdot \mathbf{B}) \hat{\mathbf{A}} \quad (2.7.11)$$

Similarly, the vector projection of \mathbf{A} onto \mathbf{B} is

$$\text{proj}_{\mathbf{B}} \mathbf{A} = \|\text{proj}_{\mathbf{B}} \mathbf{A}\| \hat{\mathbf{B}} = (\hat{\mathbf{B}} \cdot \mathbf{A}) \hat{\mathbf{B}} \quad (2.7.12)$$

The spatial interpretation of the results the scalar projection $\|\text{proj}_{\mathbf{A}} \mathbf{B}\|$ is

- *Positive values* mean that \mathbf{A} and \mathbf{B} are generally in the same direction.
- *Negative values* mean that \mathbf{A} and \mathbf{B} are generally in opposite directions.
- *Zero* means that \mathbf{A} and \mathbf{B} are perpendicular.
- *Magnitude smaller than \mathbf{B}* This is the most common answer. This means that the vectors are neither parallel nor perpendicular.
- *Magnitude equal to \mathbf{B}* means that the vectors point in the same direction, and all of \mathbf{B} acts in the direction of \mathbf{A} .
- *Magnitude larger than \mathbf{B}* This answer is impossible. Check your algebra; you might have forgotten to divide by the magnitude of \mathbf{A} .

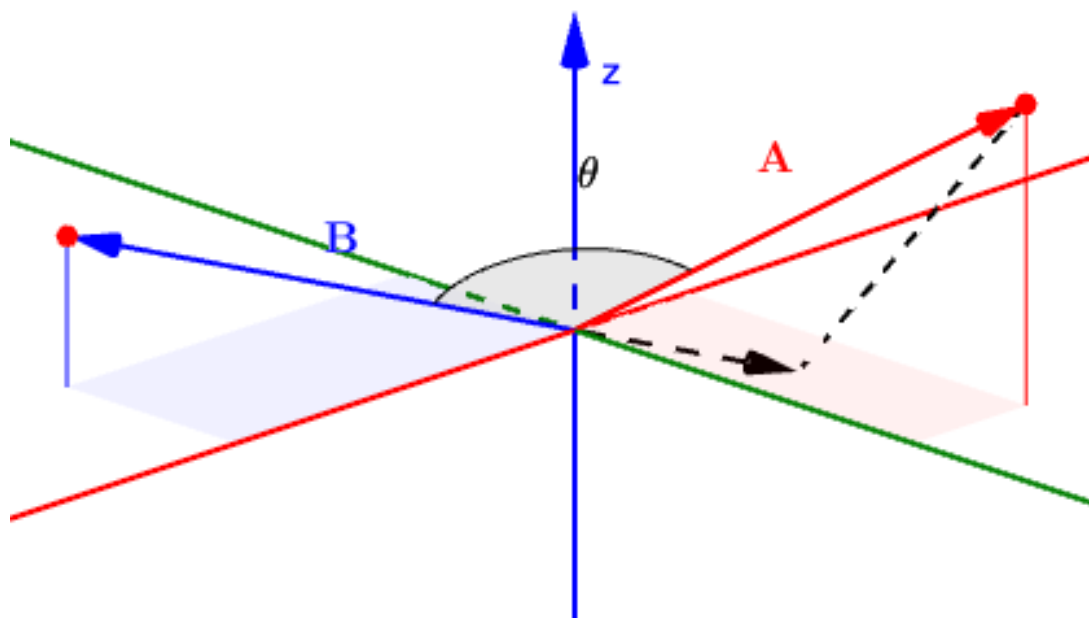

[Live Link](#)

Figure 2.7.5 Vector projections in three dimensions.

2.7.5 Perpendicular Components

The final application of dot products is to find the component of one vector perpendicular to another.

To find the component of \mathbf{B} perpendicular to \mathbf{A} , first find the vector projection of \mathbf{B} on \mathbf{A} , then subtract that from \mathbf{B} . What remains is the perpendicular component.

$$\mathbf{B}_\perp = \mathbf{B} - \text{proj}_\mathbf{A} \mathbf{B} \quad (2.7.13)$$

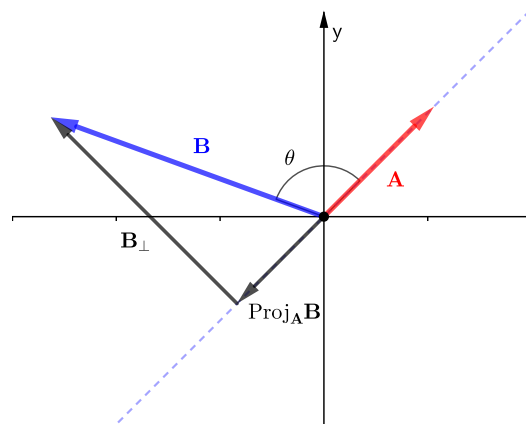
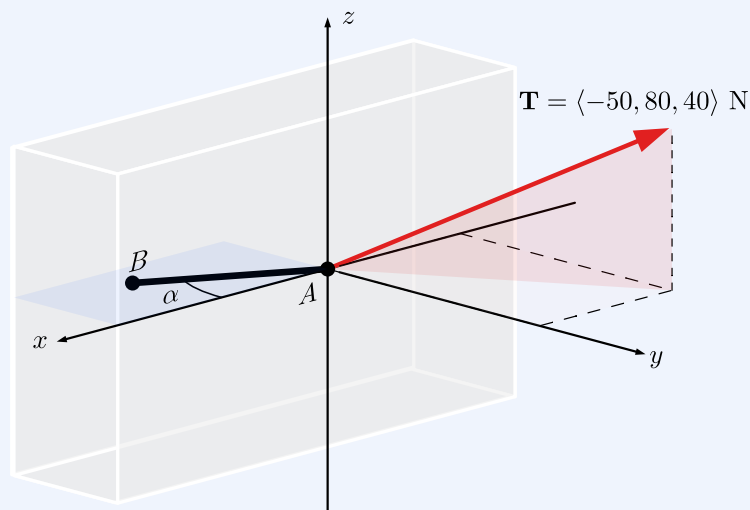

Figure 2.7.6 Perpendicular and parallel components of \mathbf{B} .

Example 2.7.7 Dot Products.

A cable pulls with tension $\mathbf{T} = \langle -50, 80, 40 \rangle$ N on a 0.4 m long anchor AB embedded in a concrete wall. The anchor lies in the xy plane at an angle $\alpha = 30^\circ$ from the x axis.



For the system above, compute the following:

- (a) Find the dot product of the cable tension \mathbf{T} and the anchor \mathbf{AB}

Answer.

$$\mathbf{T} \cdot \mathbf{AB} = -33.32 \text{ N}\cdot\text{m}$$

Solution. When you know the magnitudes and angle between two vectors, it is easiest to use the second dot product equation (2.7.2), but in this case it will be easier to find the components of \mathbf{AB} and use (2.7.1).

$$\begin{aligned}\mathbf{T} &= \langle -50, 80, 40 \rangle \text{ N} \\ \mathbf{AB} &= \langle 0.4 \cos 30^\circ, -0.4 \sin 30^\circ, 0 \rangle \text{ m} \\ &= \langle 0.3464, -0.2, 0 \rangle \text{ m}\end{aligned}$$

$$\begin{aligned}\mathbf{T} \cdot \mathbf{AB} &= T_x(AB_x) + T_y(AB_y) + T_z(AB_z) \\ &= (-50 \text{ N})(0.3464 \text{ m}) + (80 \text{ N})(-0.2 \text{ m}) + (40 \text{ N})(0 \text{ m}) \\ &= -33.32 \text{ N}\cdot\text{m}\end{aligned}$$

The units of a dot product are the product of the units of the two vectors.

(b) Find the angle θ between the cable tension \mathbf{T} and the anchor \mathbf{AB} .

Answer.

$$\theta = 144.38^\circ$$

Solution. With the dot product $\mathbf{T} \cdot \mathbf{AB}$ known from the previous step, we can use the (2.7.2) to find the angle between force \mathbf{T} and anchor.

$$\mathbf{T} \cdot \mathbf{AB} = |\mathbf{T}||\mathbf{AB}| \cos \theta = -33.32 \text{ N}\cdot\text{m}$$

The magnitude of $|\mathbf{AB}| = 0.4 \text{ m}$ was given but we need to calculate the magnitude of $|\mathbf{T}|$,

$$|\mathbf{T}| = \sqrt{(-50)^2 + 80^2 + 40^2} = 102.47 \text{ N}$$

$$\begin{aligned}\theta &= \cos^{-1} \frac{\mathbf{T} \cdot \mathbf{AB}}{|\mathbf{T}||\mathbf{AB}|} \\ &= \cos^{-1} \frac{-33.32 \text{ N}\cdot\text{m}}{(102.47 \text{ N})(0.4 \text{ m})} \\ &= 144.38^\circ\end{aligned}$$

Note that $\theta > 90^\circ$ correctly corresponds to the negative dot product and indicates that the two vectors generally oppose each other.

- (c) Find the scalar projection of the the cable tension \mathbf{T} onto the anchor \mathbf{AB} .

Answer.

$$\|\text{proj}_{\mathbf{AB}} \mathbf{T}\| = -83.30 \text{ N}$$

Solution 1. Recall from [Subsection 2.7.4](#) that the scalar projection is the scalar component of one vector in the direction of another, in other words, how much of one vector is parallel to another. This is one of the most direct and practical applications of the dot product.

The dot product of \mathbf{T} with \mathbf{AB} gives the product of the length of the anchor AB and the scalar projection of the tension in the direction of the anchor.

$$\mathbf{T} \cdot \mathbf{AB} = AB (T \cos \theta) = AB \|\text{proj}_{\mathbf{AB}} \mathbf{T}\|$$

and has units of N-m.

To find the projection, divide the dot product by the magnitude of \mathbf{AB}

$$\begin{aligned} \|\text{proj}_{\mathbf{AB}} \mathbf{T}\| &= \frac{\mathbf{T} \cdot \mathbf{AB}}{AB} = \frac{-33.32 \text{ N}\cdot\text{m}}{0.4 \text{ m}} \\ &= -83.30 \text{ N} \end{aligned}$$

Solution 2. Alternately, you can apply [\(2.7.10\)](#) and calculate the calculate the dot product of force vector \mathbf{T} with the unit vector $\widehat{\mathbf{AB}}$.

First, find the unit vector

$$\widehat{\mathbf{AB}} = \frac{\mathbf{AB}}{AB} = \frac{\langle 0.3464, -0.2, 0 \rangle \text{ m}}{0.4 \text{ m}} = \langle 0.866, -0.5, 0 \rangle$$

Or, since \mathbf{AB} is in the xy plane with its direction defined by the $\alpha = 30^\circ$, the unit vector $\widehat{\mathbf{AB}}$ is found

$$\widehat{\mathbf{AB}} = \langle \cos 30^\circ, -\sin 30^\circ, 0 \rangle = \langle 0.866, -0.5, 0 \rangle.$$

Then find the projection

$$\begin{aligned} \|\text{proj}_{\mathbf{AB}} \mathbf{T}\| &= \mathbf{T} \cdot \widehat{\mathbf{AB}} \\ &= (-50 \text{ N})(0.866) + (80 \text{ N})(-0.5) + (40 \text{ N})(0) \\ &= -83.30 \text{ N} \end{aligned}$$

- (d) Find the vector projection of the cable tension \mathbf{T} onto the anchor \mathbf{AB} .

Answer.

$$\text{proj}_{\mathbf{AB}} \mathbf{T} = \langle -72.14, 41.65, 0 \rangle \text{ N}$$

Solution. The vector projection is the scalar projection value multiplied by a unit direction vector to turn it a vector. So we multiply the scalar projection with the unit vector of $\widehat{\mathbf{AB}}$ to compute the vector projection of T onto AB .

$$\begin{aligned} \text{proj}_{\mathbf{AB}} \mathbf{T} &= \|\text{proj}_{\mathbf{AB}} \mathbf{T}\| \cdot \widehat{\mathbf{AB}} \\ &= 83.301 \text{ N} (\langle 0.866, -0.5, 0 \rangle) \\ &= \langle -72.14, 41.65, 0 \rangle \text{ N} \end{aligned}$$

- (e) Find the vector portion of cable tension \mathbf{T} perpendicular to the anchor \mathbf{AB} .

Answer.

$$\mathbf{T}_{\perp \mathbf{AB}} = \langle 22.14, 38.35, 40 \rangle \text{ N}$$

Solution. Recall that a two-dimensional vector can be represented by the sum of two perpendicular components. In the same way, a right triangle can be represented by a vector along the hypotenuse equal to the sum of the two right-triangle sides.

Thus, any vector can be divided into two vectors parallel and perpendicular to another line. The vector projection $\text{proj}_{\mathbf{AB}} \mathbf{T}$, from Part (d), is the portion of \mathbf{T} parallel to \mathbf{AB} . So the sum of \mathbf{T} can be expressed as the parallel and perpendicular terms:

$$\mathbf{T} = \text{proj}_{\mathbf{AB}} \mathbf{T} + (\mathbf{T}_{\perp \mathbf{AB}})$$

We want to find the part of \mathbf{T} perpendicular to \mathbf{AB} , so we can rearrange the equation to find:

$$\begin{aligned} \mathbf{T}_{\perp \mathbf{AB}} &= \mathbf{T} - \text{proj}_{\mathbf{AB}} \mathbf{T} \\ &= \langle -50, 80, 40 \rangle - \langle -72.14, 41.65, 0 \rangle \\ &= \langle 22.14, 38.35, 40 \rangle \text{ N} \end{aligned}$$

Nice effort if you worked through all the parts of this example. Graphically the results for parts (b), (d), and (e) are shown in this diagram.

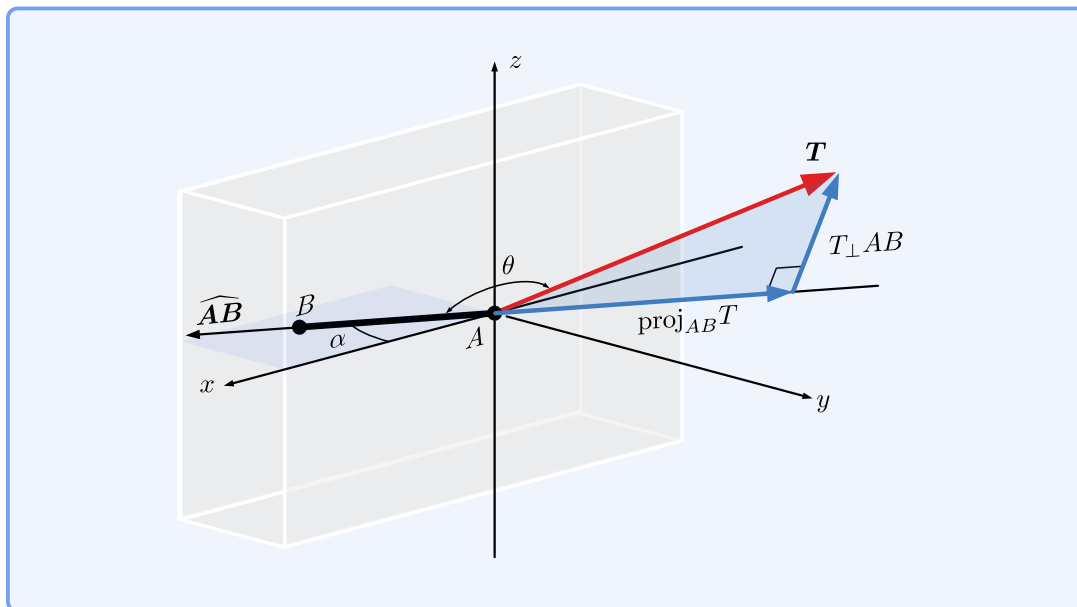

2.8 Cross Products

Key Questions

- How is a cross product different than a dot product?
- What is a determinant?
- What defines a right-handed Cartesian coordinate system?
- How do you use the cross-product circle to find the cross product of two unit vectors?

The vector **cross product** is a multiplication operation applied to two vectors which produces a third mutually perpendicular vector as a result. It's sometimes called the **vector product** to emphasize this and to distinguish it from the dot product which produces a scalar result. The \times symbol is used to indicate this operation.

Cross products are used in mechanics to find the moment of a force about a point.

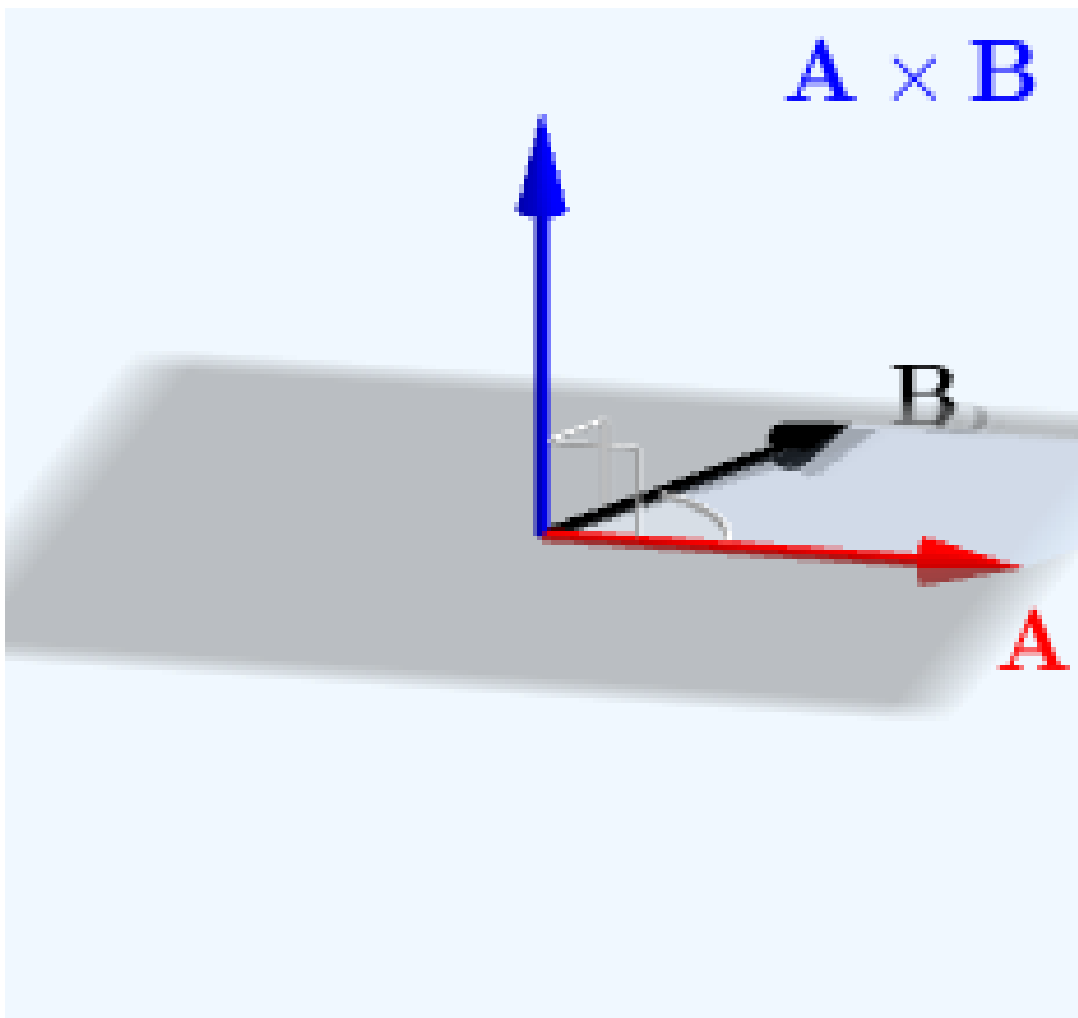

[Live Link](#)

Figure 2.8.1 Direction of a cross product.

The cross product is a vector multiplication process defined by

$$\mathbf{A} \times \mathbf{B} = A B \sin \theta \hat{\mathbf{u}}. \quad (2.8.1)$$

The result is a vector mutually perpendicular to both with a sense determined by the right-hand rule. If \mathbf{A} and \mathbf{B} are in the xy plane, this is

$$\mathbf{A} \times \mathbf{B} = (A_y B_x - A_x B_y) \mathbf{k}. \quad (2.8.2)$$

The operation is not commutative, in fact reversing the order introduces a negative sign.

$$\mathbf{A} \times \mathbf{B} = -\mathbf{B} \times \mathbf{A}.$$

The magnitude of the cross product is the product of the perpendicular component of \mathbf{A} with the magnitude of \mathbf{B} . This is the area of the parallelogram

formed by vectors \mathbf{A} and \mathbf{B} . The magnitude of the cross product is zero if \mathbf{A} and \mathbf{B} are parallel, and it is maximum when they are perpendicular. The magnitude of the cross product of two perpendicular *unit* vectors is one.

Notice that the cross product equation are similar to the dot product, except that \sin is used rather than \cos and the product includes a unit vector $\hat{\mathbf{u}}$ making the result a vector. This unit vector $\hat{\mathbf{u}}$ is simple to find in a two-dimensional problem as it will always be perpendicular to the page, but for three-dimensional cross products a vector determinant is used, as discussed in [Subsection 2.8.3](#).

2.8.1 Direction of the Vector Cross Product

The direction of a cross product is determined by the **right-hand rule**. There are two ways to apply the right-hand rule, the three-finger method, and the point-and-curl method. You don't need both, but you will need to master at least one to find the direction of cross products.

The three-finger method uses the fact that your extended index finger, middle finger, and thumb are all roughly mutually perpendicular. If you align your index finger with the first vector and your middle finger with the second, then your thumb will point in the direction of the cross product. Alternately, if you align your thumb with the first vector and your index finger with the second, your middle finger will point in the direction of the cross-product.

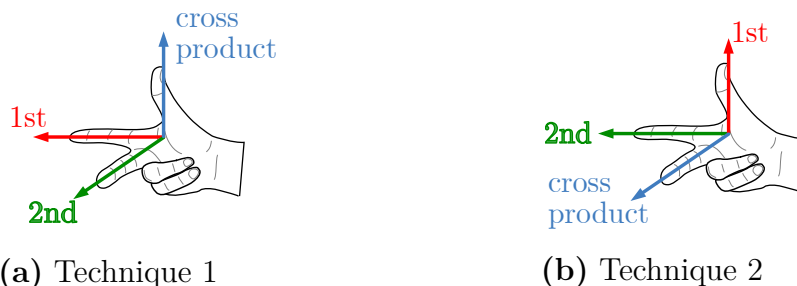

Figure 2.8.2 Right-hand rule using three fingers.

The point-and-curl method involves placing your right hand flat with your fingertips pointing in the direction of the the first vector. Then rotate your hand until the second vector is can curl your fingers around your thumb. In this position, your thumb defines the direction of the cross product.

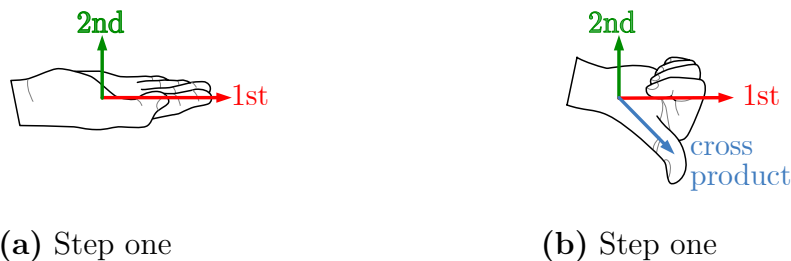
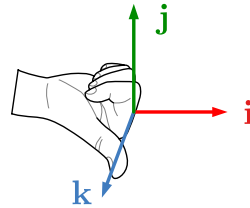
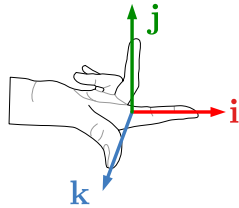

Figure 2.8.3 Right-hand rule using the point-and-curl technique.

2.8.2 Cross Product of Unit Vectors

The Figure 2.8.4(a) demonstrates how you apply these techniques to find the cross product of $\mathbf{i} \times \mathbf{j}$. Assuming the x axis points right and the y axis points up, the cross product points in the positive z direction. Recalling that the magnitude of the cross product of two perpendicular unit vectors is one, we conclude that

$$\mathbf{i} \times \mathbf{j} = \mathbf{k}.$$



(a) Using the three-finger method. (b) Using the point-and-curl method.

Figure 2.8.4 Crossing \mathbf{i} into \mathbf{j} to get \mathbf{k} .

Similarly, the cross products of the other pairs of vectors are:

$$\begin{array}{lll} \mathbf{i} \times \mathbf{i} = 0 & \mathbf{i} \times \mathbf{j} = \mathbf{k} & \mathbf{i} \times \mathbf{k} = -\mathbf{j} \\ \mathbf{j} \times \mathbf{i} = -\mathbf{k} & \mathbf{j} \times \mathbf{j} = 0 & \mathbf{j} \times \mathbf{k} = \mathbf{i} \\ \mathbf{k} \times \mathbf{i} = \mathbf{j} & \mathbf{k} \times \mathbf{j} = -\mathbf{i} & \mathbf{k} \times \mathbf{k} = 0 \end{array}$$

An alternate way to remember this is to use the cross-product circle shown. For example when you cross \mathbf{i} with \mathbf{j} you are going in the positive (counter-clockwise) direction around the blue inner circle and thus the answer is $+\mathbf{k}$. But when you cross \mathbf{j} into \mathbf{i} you go in the negative (clockwise) direction around the circle and thus get a $-\mathbf{k}$. Remember that the order of cross products matter. If you put the vectors in the wrong order you will introduce a sign error.

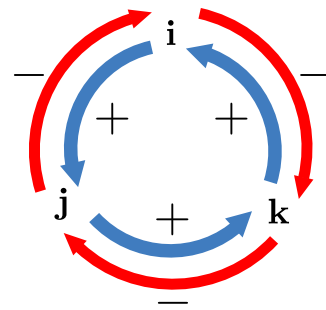

Figure 2.8.5 Unit vector cross product circle.

If you have any negative unit vectors it is easiest to pull out the negative signs before you take the cross product, like the following.

$$-\mathbf{j} \times \mathbf{i} = (-1)(\mathbf{j} \times \mathbf{i}) = (-1)(-\mathbf{k}) = +\mathbf{k}$$

2.8.3 Cross Product of Arbitrary Vectors

The cross product of two arbitrary three-dimensional vectors can be calculated by evaluating the **determinant** of this 3×3 matrix.

$$\mathbf{A} \times \mathbf{B} = \begin{vmatrix} \mathbf{i} & \mathbf{j} & \mathbf{k} \\ A_x & A_y & A_z \\ B_x & B_y & B_z \end{vmatrix} \quad (2.8.3)$$

Here, the first row contains the unit vectors, the second row contains the components of \mathbf{A} , and the third row, the components of \mathbf{B} . The determinant of this 3×3 matrix is evaluated using the method of cofactors, as follows

$$\mathbf{A} \times \mathbf{B} = + \begin{vmatrix} A_y & A_z \\ B_y & B_z \end{vmatrix} \mathbf{i} - \begin{vmatrix} A_x & A_z \\ B_x & B_z \end{vmatrix} \mathbf{j} + \begin{vmatrix} A_x & A_y \\ B_x & B_y \end{vmatrix} \mathbf{k}. \quad (2.8.4)$$

Each term contains a 2×2 determinant which is evaluated with the formula

$$\begin{vmatrix} a & b \\ c & d \end{vmatrix} = ad - bc. \quad (2.8.5)$$

After simplifying, the resulting formula for a three-dimensional cross product is

$$\mathbf{A} \times \mathbf{B} = (A_y B_z - A_z B_y) \mathbf{i} - (A_x B_z - A_z B_x) \mathbf{j} + (A_x B_y - A_y B_x) \mathbf{k}. \quad (2.8.6)$$

In practice, the easiest way to remember this equation is to use the augmented determinant below, where the first two columns have been copied and placed after the determinant. The cross product is then calculated by adding the product of the red diagonals and subtracting the product of blue diagonals. The result is identical to (2.8.6).

$$\mathbf{A} \times \mathbf{B} = \begin{vmatrix} \mathbf{i} & \mathbf{j} & \mathbf{k} & \mathbf{i} & \mathbf{j} \\ A_x & A_y & A_z & A_x & A_y \\ B_x & B_y & B_z & B_x & B_y \end{vmatrix}$$

Figure 2.8.6 Augmented determinant

In two dimensions, vectors \mathbf{A} and \mathbf{B} have no z components, so (2.8.6) reduces to

$$\mathbf{A} \times \mathbf{B} = \begin{vmatrix} \mathbf{i} & \mathbf{j} & \mathbf{k} \\ A_x & A_y & 0 \\ B_x & B_y & 0 \end{vmatrix} = (A_x B_y - A_y B_x) \mathbf{k}. \quad (2.8.7)$$

This equation produces the same result as equation (2.8.1) and you may use it if it is more convenient.

Example 2.8.7 2D Cross Product.

The two vectors \mathbf{A} and \mathbf{B} shown lie in the xy plane. Determine the cross product $\mathbf{A} \times \mathbf{B}$.

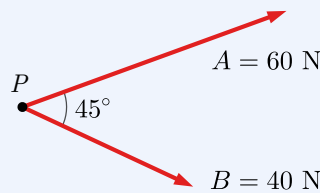

Solution 1. In this solution we will apply equation (2.8.1).

$$\mathbf{A} \times \mathbf{B} = A B \sin \theta \hat{\mathbf{u}}$$

The direction of the cross product is determined by applying the right-hand rule. With the right hand, rotating \mathbf{A} towards \mathbf{B} we find that our thumb points into the xy plane, so the direction of $\hat{\mathbf{u}}$ is $-\mathbf{k}$.

$$\begin{aligned} \mathbf{A} \times \mathbf{B} &= (60 \text{ N})(40 \text{ N}) \sin 45^\circ (-\mathbf{k}) \\ &= 1,697 \text{ N}^2 (-\mathbf{k}) \\ &= -1,697 \text{ N}^2 \mathbf{k} \end{aligned}$$

Solution 2. In this solution we will use (2.8.7).

First, establish a coordinate system with the origin P and with the x axis aligned with \mathbf{A} , then find the rectangular components and apply the cross product equation.

$$\begin{array}{ll} A_x = 60 \text{ N} & A_y = 0 \text{ N} \\ B_x = 40 \text{ N} \cos 45^\circ & B_y = -40 \text{ N} \sin 45^\circ \\ = 28.28 \text{ N} & = -28.28 \text{ N} \end{array}$$

$$\begin{aligned} \mathbf{A} \times \mathbf{B} &= (A_x B_y - A_y B_x) \mathbf{k} \\ &= (60)(-28.28) - (0)(28.28) \text{ N}^2 \mathbf{k} \\ &= -1697 \text{ N}^2 \mathbf{k} \end{aligned}$$

Example 2.8.8 3D Cross Product.

Find the cross product of $\mathbf{A} = \langle 2, 4, -1 \rangle$ m and $\mathbf{B} = \langle 10, 25, 20 \rangle$ N. Here, we are crossing a *distance* \mathbf{A} and with a *force* \mathbf{B} . This calculation is equivalent to finding the moment about a point P caused by force \mathbf{B} acting

distance \mathbf{A} from P . You will learn about moments in [Chapter 4](#).

Solution 1. To solve, set up the augmented determinant and evaluate it by adding the left-to-right diagonals and subtracting the right-to-left diagonals using equation (2.8.6).

$$\begin{aligned}\mathbf{A} \times \mathbf{B} &= \begin{vmatrix} \mathbf{i} & \mathbf{j} & \mathbf{k} & | & \mathbf{i} & \mathbf{j} \\ 2 & 4 & -1 & | & 2 & 4 \\ 10 & 25 & 20 & | & 10 & 25 \end{vmatrix} \\ &= (4 \cdot 20) \mathbf{i} + (-1 \cdot 10) \mathbf{j} + (2 \cdot 25) \mathbf{k} - (4 \cdot 10) \mathbf{k} - (-1 \cdot 25) \mathbf{i} - (2 \cdot 20) \mathbf{j} \\ &= (80 + 25) \mathbf{i} + (-10 - 40) \mathbf{j} + (50 - 40) \mathbf{k} \\ &= \langle 105, -50, 10 \rangle \text{ N}\cdot\text{m}\end{aligned}$$

Thus, the force \mathbf{B} creates a three-dimensional rotational moment equal to $\langle 105, -50, 10 \rangle \text{ N}\cdot\text{m}$.

Solution 2. Calculating three-dimensional cross products by hand is tedious and error-prone. Whenever you can, you should use technology to do the grunt work for you and focus on the meaning of the results. In this solution, we will use an embedded Sage calculator to calculate the cross product. This same calculator can be used to do other problems.

Given:

$$\begin{aligned}\mathbf{A} &= \langle 2, 4, -1 \rangle \text{ m} \\ \mathbf{B} &= \langle 10, 25, 20 \rangle \text{ N}\end{aligned}$$

\mathbf{A} and \mathbf{B} are defined in the first two lines, and `A.cross_product(B)` is the expression to be evaluated. Click **Evaluate** to see the result. You'll have to work out the correct units for yourself.

```
A = vector([2, 4, -1]);
B = vector([10, 25, 20]);
A.cross_product(B)
```

```
(-105, -50, 10)
```

Try changing the third line to `B.cross_product(A)`. What changes?

2.9 Exercises (Ch. 2)

Chapter 2 Exercises

Vectors	0/140
Rectangular components: P to R	0/20 Not attempted
Rectangular components: R to P	0/20 Not attempted
Find magnitude and direction of three vectors	0/60 Not attempted
Parallelogram Rule	0/20 Not attempted
Arbitrary components	0/20 Not attempted
Vector Addition 0/200	
Tip-to-tail method	0/20 Not attempted
Parallelogram rule	0/30 Not attempted
Summing scalar components	0/60 Not attempted
Vector addition of three forces	0/20 Not attempted
Vector addition by summing scalar components	0/40 Not attempted
Description only	0/30 Not attempted

Display options

Done

Created using Numbas v9.1, developed by [Newcastle University](#)



Standalone
In Context

Chapter 3

Equilibrium of Particles

3.1 Equilibrium

Engineering statics is the study of rigid bodies in equilibrium so it's appropriate to begin by defining what we mean by *rigid bodies* and what we mean by *equilibrium*.

A **body** is an object, possibly made up of many parts, which may be examined as a unit. In statics, we consider the forces acting on the object as a whole and also examine it in greater detail by studying each of its parts, which are bodies in their own right. The choice of the body is an engineering decision based on what we are interested in finding out. We might, for example, consider an entire high-rise building as a body for the purpose of designing the building's foundation, and later consider each column and beam of the structure to ensure that they are strong enough to perform their individual roles.

A **rigid body** is a body that doesn't deform under load, that is to say, an object which doesn't bend, stretch, or twist when forces are applied to it. It is an idealization or approximation because no objects in the real world behave this way; however, this simplification still produces valuable information. You will drop the rigid body assumption and study deformation, stress, and strain in a later course called Strength of Materials or Mechanics of Materials. In that course, you will perform analysis of non-rigid bodies, but each problem you do *there* will begin with the rigid body analysis you will learn to do *here*.

A body in **equilibrium** is not accelerating. As you learned in physics, acceleration is velocity's time rate of change and is a vector quantity. For linear motion,

$$\mathbf{a} = \frac{d\mathbf{v}}{dt}.$$

For an object in equilibrium $\mathbf{a} = 0$ which implies that the body is either stationary or moving with a constant velocity

$$\mathbf{a} = 0 \implies \begin{cases} \mathbf{v} = 0 \\ \mathbf{v} = C. \end{cases}$$

The acceleration of an object is related to the net force acting on it by **Newton's Second Law**

$$\Sigma \mathbf{F} = m\mathbf{a}.$$

So for the special case of static equilibrium Newton's Law becomes

$$\Sigma \mathbf{F} = 0. \quad (3.1.1)$$

This simple equation is one of the two foundations of engineering statics.

There are several ways to think about this equation. Reading it from left to right it says that *if all the forces acting on a body sum to zero, then the body will be in equilibrium*. If you read it from right to left it says that *if a body is in equilibrium, then all the forces acting on the body must sum to zero*. Both interpretations are equally valid but we will be using the second one more often. In a typical problem equilibrium of a body implies that the forces sum to zero, and we use that fact to find the unknown forces which make it so. Remember that we are talking about vector addition here, so the sums of the forces must be calculated using the rules of vector addition; you won't get correct answers if you can't add vectors!

We'll be using all of the different vector addition techniques introduced in [Section 2.6](#), which may lead to some confusion. It doesn't matter, mathematically, which technique you use but part of the challenge and reward of statics is learning to select the best tool for the job at hand; to select the simplest, easiest, fastest, or clearest way to get to the solution. You'll do best in this course if you can use multiple approaches to solve the same problem.

In [Chapter 5](#) we will add another requirement for equilibrium, namely equilibrium equation (5.3.2) which says the forces which cause rotational motion and angular acceleration α also must sum to zero, but for the problems of this chapter the only condition we'll need for equilibrium is $\Sigma \mathbf{F} = 0$.

3.2 Particles

We'll begin our study of Equilibrium with the simplest possible object in the simplest possible situation — a **particle** in a **one-dimensional coordinate system**. Also, in this chapter and the next all forces will be represented as **concentrated forces**. In later sections, we will address more complicated situations, higher dimensions, and distributed forces, but beginning with very simple situations will help you to develop engineering sense and problem-solving skills which will be useful later.

The defining characteristic of a particle is that all forces that act on it are coincident¹ or concurrent², not that it is small. Forces are coincident if they have the same line of action, and concurrent if they intersect at a point. The moon, earth and sun can all be treated as particles, but we probably won't encounter

¹Two lines are coincident when one lies on top of the other.

²Two or more lines are concurrent if they intersect at a single point.

them in statics since they're not in equilibrium. Forces are coincident/concurrent if their lines of action all intersect at a single, common point. Two or more forces are also considered concurrent if they share the same line of action. One practical consequence of this is that particles are never subjected to forces that cause rotation. So a see-saw, for example, is not a particle because the weights of the children tend ³ to cause rotation.

Another consequence of concurrent forces is that Equation (3.1.1) is the only equilibrium equation that applies. This vector equation can be used to solve for a maximum of one unknown per dimension. If you find yourself trying to solve a two-dimensional particle equilibrium problem and you are seeking more than two unknowns, it's likely that you have missed something and need to re-read the question.

Another simplification we will be making is to treat all forces as **concentrated**. Concentrated forces act at a single point, have a well-defined line of action, and can be represented with an arrow — in other words, they are vectors. Real forces don't actually act at a single mathematical point but concentrating them is intuitive and will be justified in a [later chapter 7.8](#). You're already familiar with the concept if you have ever placed all the weight of an object at its center of gravity.

3.3 1D Particle Equilibrium

3.3.1 A simple case

Consider the weight suspended by a rope shown in [Figure 3.3.1](#). Diagrams of this type are called **space diagrams**; they show the objects as they exist in space.

In mechanics we are interested in studying the forces acting on objects and in this course, the objects will be in equilibrium. The best way to do this is to draw a diagram that focuses on the forces acting on the object, not the mechanisms that hold it in place. We call this type of diagram a free-body diagram because it shows the object disconnected or freed from its supporting mechanisms. You can see the free-body diagram for this situation by moving the slider in the interactive to position two. This shows that there are two forces acting on the object; the force of the rope holding it up, and the weight of the object which is trying to pull it to earth, which we treat as acting at its center of gravity.

³We say “tend to cause rotation” because in a static's context, all objects are static — so no actual rotation occurs.

The actual shape of the weight is not important to us, so it can simply be represented with a dot, as shown when the view control is in position three. The forces have been slid along their common line of action until they both act on the dot, which is an example of an [equivalent transformation](#) called the “Principle of Transmissibility.” This diagram in view three is completely sufficient for this situation.

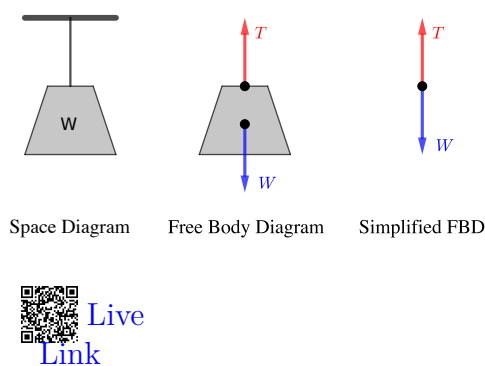

Figure 3.3.1 A suspended weight

Drawing free-body diagrams can be surprisingly tricky. The reason for this is that you must identify all the forces acting on the object and correctly represent them on the free-body diagram. If you fail to account for all the forces, include additional ones, or represent them incorrectly, your analysis will surely be wrong.

So what kind of analysis can we do here? Admittedly not much. We can find the tension in the rope caused by a particular weight and use it to select an appropriately strong rope, or we can determine the maximum weight a particular rope can safely support.

The actual analysis is so trivial that you’ve probably already done it in your head, nevertheless several ways to approach it will be shown next.

In the vector approach we will use the [equation of equilibrium](#).

Example 3.3.2 1D Vector Addition.

Find the relationship between the tension in the rope and the suspended weight for the system of [Figure 3.3.1](#).

Solution.

The free-body diagram shows two forces acting on the particle, and since the particle is in equilibrium they must add to zero.

$$\begin{aligned}\Sigma \mathbf{F} &= 0 \\ \mathbf{T} + \mathbf{W} &= 0 \\ \mathbf{T} &= -\mathbf{W}\end{aligned}$$

We conclude that force \mathbf{T} is equal and opposite to \mathbf{W} , that is, since the weight is acting down, the rope acts with the same magnitude but up.

Tension is the magnitude of the rope’s force. Recall that the magnitude of a vector is always a positive scalar. We use normal (non-bold) typefaces or absolute value bars surrounding a vector to indicate its magnitude. For any force \mathbf{F} ,

$$F = |\mathbf{F}|.$$

To find how the tension is related to \mathbf{W} , take the absolute value of both sides

$$|\mathbf{T}| = |-\mathbf{W}|$$

$$T = W$$

We can also formulate this example in terms of unit vectors. Recall that \mathbf{j} is the unit vector that points up. It has a magnitude of one with no units associated. So in terms of unit vector \mathbf{j} , $\mathbf{T} = T\mathbf{j}$ and $\mathbf{W} = -W\mathbf{j}$.

Example 3.3.3 1D Vector Addition using unit vectors.

Find the relation between the tension T and weight W for the system of [Figure 3.3.1](#) using unit vectors.

Solution.

Express the forces in terms of their magnitudes and the unit vector \mathbf{j} then proceed as before,

$$\begin{aligned}\Sigma\mathbf{F} &= 0 \\ \mathbf{T} + \mathbf{W} &= 0 \\ T\mathbf{j} + W(-\mathbf{j}) &= 0 \\ T\mathbf{j} &= W\mathbf{j} \\ T &= W\end{aligned}$$

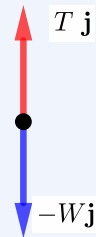

In the previous example, the unit vector \mathbf{j} completely dropped out of the equation leaving only the coefficients of \mathbf{j} . This will be the case whenever you add vectors which all act along the same line of action.

The coefficients of \mathbf{i} , \mathbf{j} , and \mathbf{k} are known as the **scalar components**. A scalar component times the associated unit vector is a force vector.

When you use scalar components, the forces are represented by scalar values and the equilibrium equations are solved using normal algebraic addition rather than vector addition. This leads to a slight simplification of the solution as shown in the next example.

Example 3.3.4 1D Vector Addition using scalar components.

Find the relation between the tension T and weight W for the system of [Figure 3.3.1](#) using scalar components.

Solution.

The forces in this problem are $\mathbf{W} = -W \mathbf{j}$ and $\mathbf{T} = T \mathbf{j}$, so the corresponding scalar components are

$$W_y = -W \qquad T_y = T$$

Adding scalar components gives,

$$\begin{aligned} \Sigma F_y &= 0 \\ W_y + T_y &= 0 \\ -W + T &= 0 \\ T &= W \end{aligned}$$

Unsurprisingly, we get the same result.

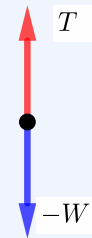

3.3.2 Scalar Components

The scalar component of a vector is a *signed* number which indicates the vector's **magnitude** and **sense**, and is usually identified by a symbol with a subscript which indicates the line of action of the vector.

So for example, $F_x = 10 \text{ N}$ is a scalar component. We can tell it's not a vector because it F_x is not bold. 10 N is the magnitude of the associated vector; the subscript x indicates that the force acts “in the x direction,” in other words it acts on a line of action which is parallel to the x axis; and the (implied) positive sign means that the vector points towards the positive end of the x axis — towards positive infinity. So a scalar component, while not a vector, contains all the information necessary to completely describe and draw the corresponding vector. Be careful not to confuse scalar components with vector magnitudes. A force with a magnitude of 10 N can point in any direction, but can never have a negative magnitude.

Scalar components can be added together algebraically, but only if they act “in the same direction.” It makes no sense to add F_x to F_y . If that's what you want to do, first you must convert the scalar components to vectors, then add them according to the rules of vector addition.

Example 3.3.5 1D Scalar Addition.

If $A_x = 10 \text{ lb}$ and $B_x = -15 \text{ lb}$, find the magnitude and direction of their resultant \mathbf{R} .

Solution. Start by sketching the two forces. The subscripts indicate the line of action of the force, and the sign indicates the direction along the line of action. A negative B_x points towards the negative end of the x axis.

$$\begin{aligned}
 R &= A_x + B_x \\
 &= 10 \text{ lb} + -15 \text{ lb} \\
 &= -5 \text{ lb}
 \end{aligned}$$

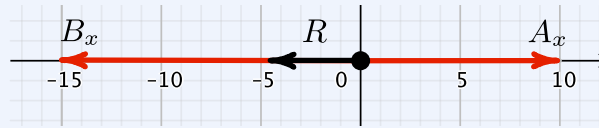

R is the scalar component of the resultant \mathbf{R} .

The negative sign on the result indicates that the resultant force acts to the left.

Example 3.3.6 2D Scalar Addition.

If $F_x = -40 \text{ N}$ and $F_y = 30 \text{ N}$, find the magnitude and direction of their resultant \mathbf{F} .

Solution. In this example the scalar components have different subscripts indicating that they act along different lines of action, and this must be accounted for when they are added together.

Make a sketch of the two vectors and add them using the parallelogram rule. In this case, the parallelogram is a rectangle, so right-triangle trig is appropriate.

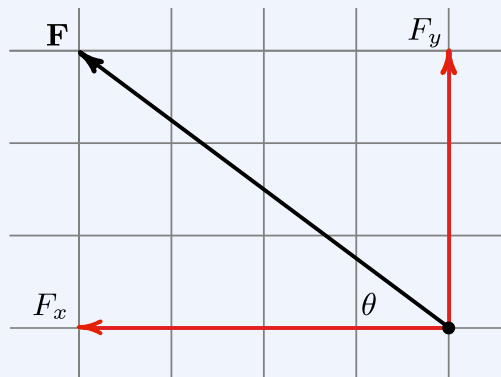

$$\begin{aligned}
 F &= \sqrt{F_x^2 + F_y^2} \\
 &= \sqrt{(-40 \text{ N})^2 + (30 \text{ N})^2} \\
 &= 50 \text{ N}
 \end{aligned}$$

$$\begin{aligned}
 \theta &= \tan^{-1} \left| \frac{F_y}{F_x} \right| \\
 &= \tan^{-1} \left| \frac{30 \text{ N}}{-40 \text{ N}} \right| \\
 &= 36.9^\circ
 \end{aligned}$$

θ is measured from the negative x axis. The direction of \mathbf{F} from the positive

x axis is $(180^\circ - \theta) = 143.1^\circ$, so

$$\mathbf{F} = 50 \text{ N at } 143.1^\circ \angle$$

3.3.3 Two-force Bodies

As you might expect from the name, a **two-force body** is a body with two forces acting on it, like the weight just discussed. As we just saw, in order for a two-force body to be in equilibrium the two forces must add to zero. There are only three possible ways that this can happen:

The two forces must either

- share the same line of action, have the same magnitude, and point away from each other, or
- share the same line of action, have the same magnitude, and point towards each other, or
- both forces have zero magnitude.

When two forces have the same magnitude but act in diametrically opposite directions, we say that they are **equal-and-opposite**. When equal and opposite forces act on an object and they point towards each other we say that the object is **in compression**, when they point away from each other the object is **in tension**. Tension and compression describe the internal state of the object.

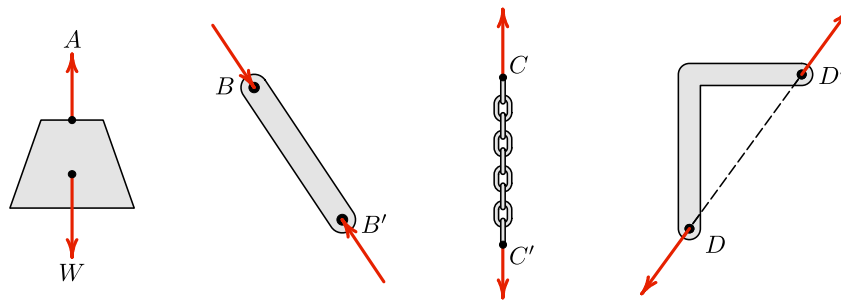

Figure 3.3.7 Examples of two-force bodies

Did you notice that last three examples in [Figure 3.3.7](#) did not include the object's weight? These are simplifications that ignore the object's weight to make them two-force bodies. If the object's weight was included, it would be a *three-force* body. This approximation is justifiable when the object's weight is small in comparison with the tensile or compressive forces. In this case, we say that the weight is **negligible**, i.e. small enough to neglect. Also note that all these examples show single forces acting at each point. If several forces act at a point, they should be combined into a single resultant force acting there.

Two force bodies appear frequently in multipart structures and machines which will be covered in [Chapter 6](#). Some examples of two force bodies are struts and linkages, ropes, cables and guy wires, and springs.

Thinking Deeper 3.3.8 Locating the Center of Gravity.

As we will see in [Chapter 7](#), the center of gravity is the point where all the weight of an object can be considered to be concentrated.

An object suspended by a cable or a frictionless pin is a two-force body. When hung freely it will naturally rotate until its center of gravity lies directly beneath the support point to ensure that the lifting force and the weight share the same line of action. This means that the center of gravity of an object can be found by suspending it from several different points, and noting intersection of lines drawn straight down from the hook (like a plumb bob).

In practical terms, to safely lift a heavy object with a chain fall or crane, you must always ensure that the hook is directly above the center of gravity before hoisting the load. The load will be unstable if lifted from any other point.

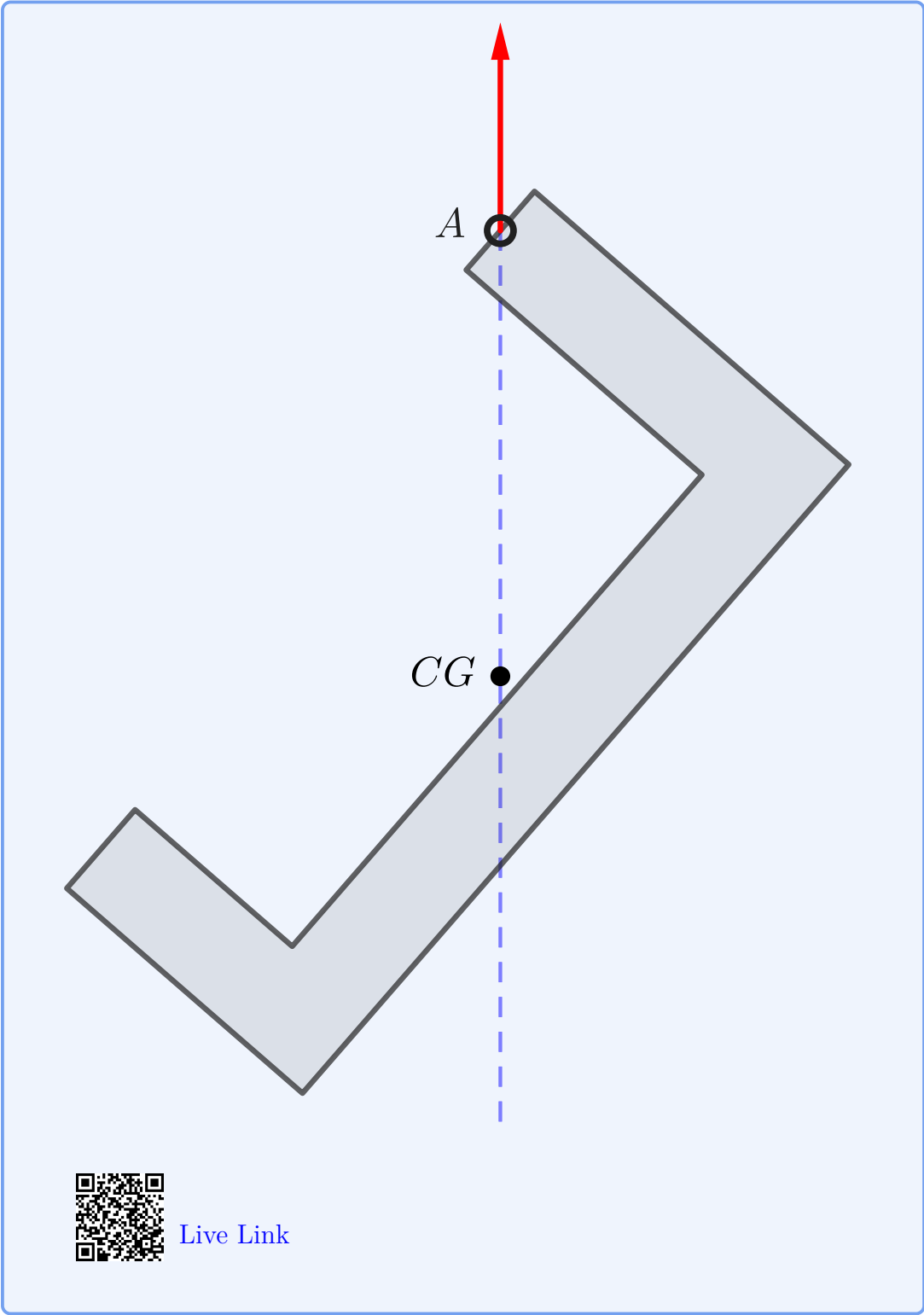

[Live Link](#)

Example 3.3.9 Tug of War.

Marines and Airmen at Goodfellow Air Force Base are competing in a tug of war and have reached a stalemate. The Marines are pulling with a force of 1500 lb. How hard are the Airmen pulling? What is the tension in the rope?



This is a simple question, but students often get it wrong at first.

Solution.1. *Assumptions.*

A free-body diagram of the rope is shown.

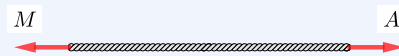
**Figure 3.3.10**

We'll solve this with scalar components because there's no need for the additional complexity of the vector approaches in this simple situation.

We'll align the x axis with the rope with positive to the right as usual to establish a coordinate system.

Assume that the pull of each team can be represented by a single force. Let force M be supplied by the Marines and force A by the Airmen; call the tension in the rope T .

Assume that the weight of the rope is negligible; then the rope can be considered a particle because both forces lie along same line of action.

2. *Givens.*

$$M = 1500 \text{ lb.}$$

3. *Procedure.*

Since they're stalemated we know that the rope is in equilibrium.

Applying the equation of equilibrium gives:

$$\begin{aligned}\Sigma F_x &= 0 \\ -M + A &= 0 \\ A &= M \\ &= 1500 \text{ lb}\end{aligned}$$

We find out that both teams pull with the same force. This was probably obvious without drawing the free-body diagram or solving the equilibrium equation.

It may seem equally obvious that if both teams are pulling with 1500 lb in opposite directions that the tension in the rope must be 3000 lb. This is wrong however.

The tension in the rope T is an example of an internal force and in order to learn its magnitude we need a free-body diagram which includes force T . To expose the internal force we take an imaginary cut through the rope and draw (or imagine) a free-body diagram of either half of the rope.

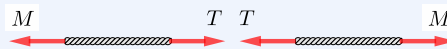

Figure 3.3.11

The correct answer is easily seen to be $T = A = M = 1500 \text{ lb}$.

Example 3.3.12 Hanging Weight.

The wire spool being lifted into the truck consists of 750 m of three strand medium voltage (5 kV) 1/0 AWG electrical power cable with a 195 amp capacity at 90°C, weighing 927 kg/km, on a 350 kg steel reel.

How much weight is supported by the hook and high tension polymer lifting sling?



Solution. The entire weight of the wire and the spool is supported by the hook and sling.

Remember that weight is not mass and mass is not force. The total weight is found by multiplying the total mass by the gravitational constant g .

$$W = mg$$

$$\begin{aligned} &= (m_w + m_s)g \\ &= ((0.75 \text{ km})(927 \text{ kg/km}) + 350 \text{ kg})g \\ &= (1045 \text{ kg})(9.81 \text{ m/s}^2) \\ &= 10300 \text{ N} \end{aligned}$$

Question 3.3.13

How can we apply the principles of mechanics in the two previous examples if the rope and the sling are clearly not “rigid bodies?”

Answer. They are not rigid, but they are inextensible and in tension. Under these conditions they don’t change shape, so we can treat them as rigid. If the force were to change direction and put either into compression, our assumptions and analysis would fail. That is why “tug of war” involves pulling and not pushing.

3.3.4 General Procedure

The general procedure for solving one, two, or three-dimensional particle equilibrium problems is essentially the same. Start with the 5-step method for creating a free-body diagram and solve for your unknowns using your equilibrium equations.

Draw a Free-Body Diagram

1. *Select and isolate the particle.* The “free-body” in free-body diagram means that a concurrent force particle or connection must be isolated from the supports physically holding it in place. This means creating a separate free-body diagram from your problem sketch.
2. *Establish a coordinate system.* This step is simple for one-dimensional problems: just label a positive direction for the forces.
3. *Identify all loads.* Include force vectors on your free-body diagram representing each applied load pushing or pulling the body, in addition to the body’s weight, if it is non-negligible. Every vector should have a descriptive variable name and a clear arrowhead indicating its direction.
4. *Identify all reactions.* Reactions represent the resistance of the physical supports you cut away by isolating the body in step 1. All particle supports are two-force members that result in tension or compression forces. Label each reaction with a descriptive variable name and a clear arrowhead.
5. *Label the diagram.* Verify that every force is labeled with either a value or a symbolic name if the value is unknown. Your final free-body diagram

should be a stand-alone presentation and is the basis of your equilibrium equations.

Create and Solve Equilibrium Equations

1. *Write the equilibrium equation.* Now represent your free-body diagram as an equilibrium equation. Your computation should start with the governing equation, like $\Sigma \mathbf{F} = 0$.
2. *Solve for unknown.* Use algebra to simplify the equilibrium equation and solve for the unknown value. Write the unit of your answer. All answers in engineering have units unless you *prove* that they don't. Finally, underline or box your answers.
3. *Check your work.* Do the results seem reasonable given the situation? Have you included appropriate units?

3.4 2D Particle Equilibrium

3.4.1 Introduction

In this section we will study situations where everything of importance occurs in a two-dimensional plane and the third dimension is not involved. Studying two-dimensional problems is worthwhile because they illustrate all the important principles of engineering statics while being easier to visualize and less mathematically complex.

We will normally work in the “plane of the page,” that is, a two-dimensional Cartesian plane with a horizontal x axis and a vertical y axis discussed in [Section 2.3](#) previously. This coordinate system can represent either the front, side, or top view of a system as appropriate. In some problems it may be worthwhile to **rotate the coordinate** system, that is, to establish a coordinate system where the x and y axes are not horizontal and vertical. This is usually done to simplify the mathematics by avoiding simultaneous equations.

3.4.2 General Procedure

The general procedure for solving two-dimensional particle equilibrium is a step up from solving [Subsection 3.3.1](#), as you now need to find equilibrium in two independent directions. The major difference is that you must carefully find each independent vector component and then solve for the equilibrium in each component direction. The process follows the same five-step method for creating a free-body diagram, followed by steps to solve your equilibrium equations.

Draw a Free-Body Diagram:

1. *Select and isolate the particle.* The “free-body” in free-body diagram means that a concurrent force particle or connection must be isolated from the supports that are physically holding it in place. This means creating a separate free-body diagram from your problem sketch.
2. *Establish a coordinate system.* Draw a right-handed coordinate system to use as a reference for your equilibrium equations. Look ahead and select a coordinate system that minimizes the number of force components. This will simplify your vector algebra. The choice is technically arbitrary, but a good choice will simplify your calculations and reduce your effort.
3. *Identify all loads.* Add force vectors to your free-body diagram representing each applied load pushing or pulling the body, in addition to the body’s weight, if it is non-negligible. If a force vector has a known direction, draw it. If its direction is unknown, assume one, and your later algebra will check your assumption. Every vector should have a descriptive variable name and a clear arrowhead indicating its direction.
4. *Identify all reactions.* Reactions represent the resistance of the physical supports you cut away by isolating the body in step 1. All particle supports are some type of two-force members with tension or compression reaction forces. These reactions will all be concurrent with the body loads from Step 2. Label each reaction with a descriptive variable name and a clear arrowhead. Again, if a vector’s direction is unknown, just assume one.
5. *Label the diagram.* Verify that every dimension, angle, force, and moment is labeled with either a value or a symbolic name if the value is unknown. In our eyes, dimensioning is optional. Having the information needed for your calculations is helpful, but don’t clutter the diagram up with unneeded details. Your final free-body diagram should be a stand-alone presentation and is the basis of your equilibrium equations.

Create and Solve Equilibrium Equations

1. *Break vectors into components.* Compute each force’s x and y components using right-triangle trigonometry.
2. *Write equilibrium equations.* Now represent your free-body diagram as two equilibrium equations, $\Sigma \mathbf{F}_x = 0$ and $\Sigma \mathbf{F}_y = 0$.
3. *Count knowns and unknowns.* At this point, you should have at most two unknown values. If you have more than two, reread the problem and look for overlooked information.
4. *Solve for unknowns.* Use algebra to simplify the equilibrium equations and solve for unknowns. All answers in Statics will have units - unless you have solved for a dimensionless value, like a friction coefficient. Finally, underline or box your answers.

5. *Check your work.* If you add the components of the forces, do they add to zero? Do the results seem reasonable given the situation? Have you included appropriate units?

3.4.3 Force Triangle Method

The force triangle method applies to situations where there are (exactly) three forces acting on a particle, and no more than two unknown magnitudes or directions.

If such a particle is in equilibrium then the three forces must add to zero. Graphically, if you arrange the force vectors tip-to-tail, they will form a closed, three-sided polygon, i.e. a triangle. This is illustrated in [Figure 3.4.1](#).

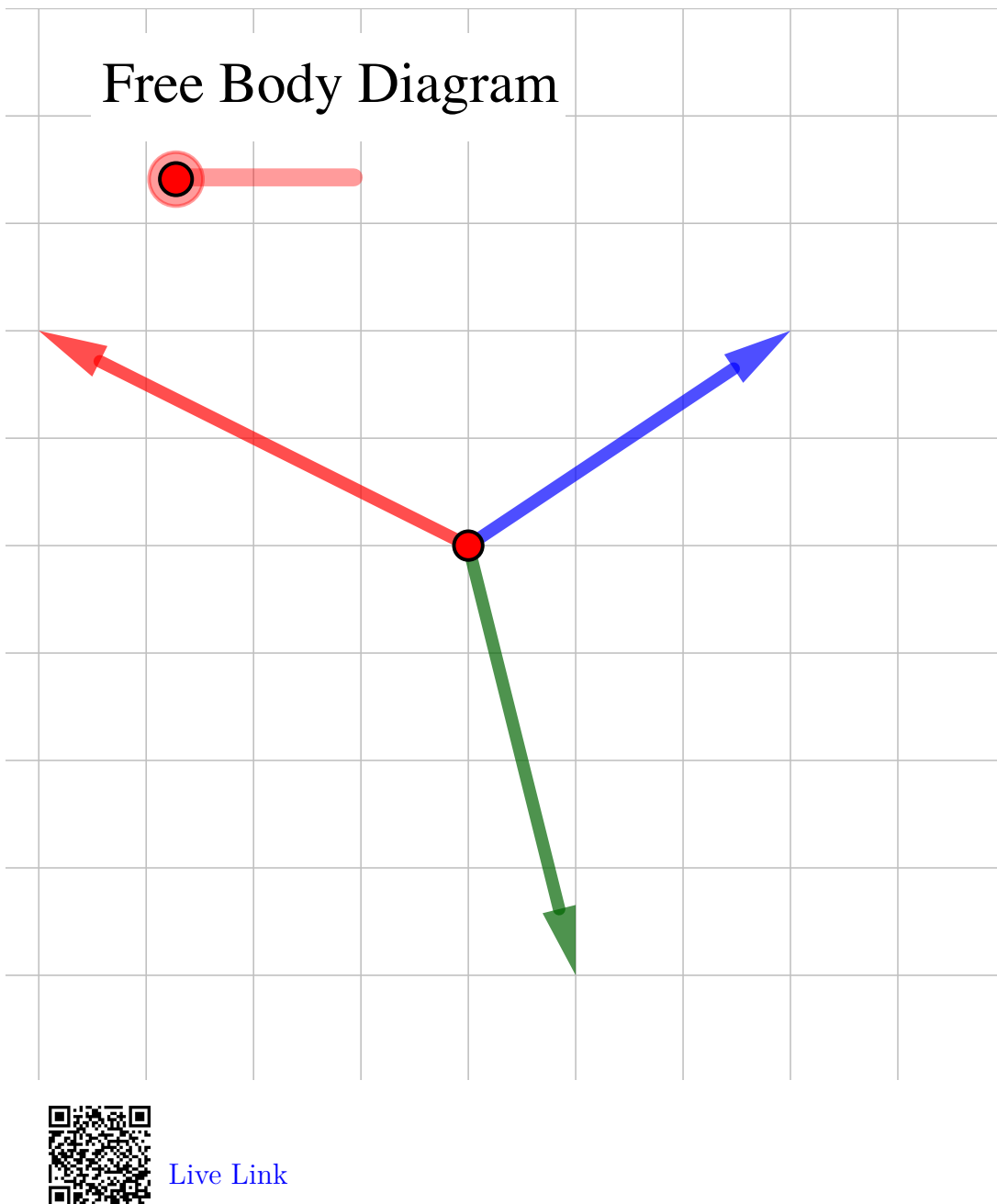

Figure 3.4.1 Free-Body Diagram and Force Triangle

Question 3.4.2

Why do the forces always form a closed polygon?

Answer. Because their resultant is zero.

The force triangle is a graphical representation of the vector [equilibrium equation \(3.1.1\)](#). It can be used to solve for unknown values in multiple different ways, which will be illustrated in the next two examples. In [Example 3.4.3](#) We will use

a graphical approach to find the forces causing equilibrium, and in [Example 3.4.4](#) we will use trigonometry to solve for the unknown forces mathematically.

In the next example we will use technology to draw a scaled diagram of the force triangle representing the equilibrium situation. We are using [Geogebra](#) to make the drawing, but you could use CAD, another drawing program, or even a ruler and protractor as you prefer. Since the diagram is accurately drawn, the lengths and angles represent the magnitudes and directions of the forces which hold the particle in equilibrium.

Example 3.4.3 Frictionless Incline.

A force P is being applied to a 100 lb block resting on a frictionless incline as shown. Determine the magnitude and direction of force P and of the contact force on the bottom of the block.

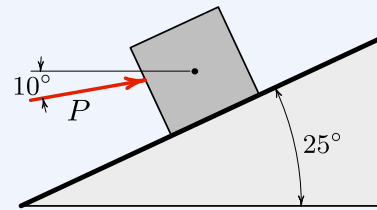

Solution.

1. Assumptions.

We must assume that the block is in equilibrium, that is, either motionless or moving at a constant velocity in order to use the equilibrium equations. We will represent the block's weight and the force between the incline and the block as concentrated forces. The force of the inclined surface on the block must act in a direction that is normal to the surface since it is frictionless and can't prevent motion along the surface.

2. Givens.

The knowns here are the weight of the block, the direction of the applied force, and the slope of the incline. The slope of the incline provides the direction of the normal force.

The unknown values are the magnitudes of forces P and N .

3. Free-Body Diagram.

You should always begin a statics problem by drawing a free-body diagram. It allows you to think about the situation, identify knowns and unknowns, and define symbols.

We define three symbols, W , N , and P , representing the weight, normal force, and applied force respectively. The angles could be given symbols too, but since we know their values it isn't necessary.

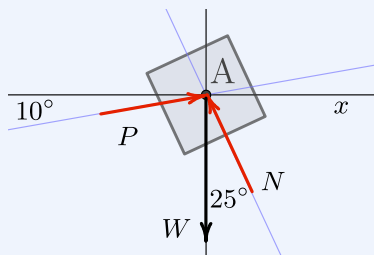

The free-body can be a quick sketch or an accurate drawing but it must show *all* the forces acting on the particle and define the symbols. In most cases, you won't know the magnitudes of all the forces, so the lengths of the vectors are just approximate.

Notice that the force N is represented as acting 25° from the y axis, which is 90° away from the direction of the surface.

4. *Force Triangle.*

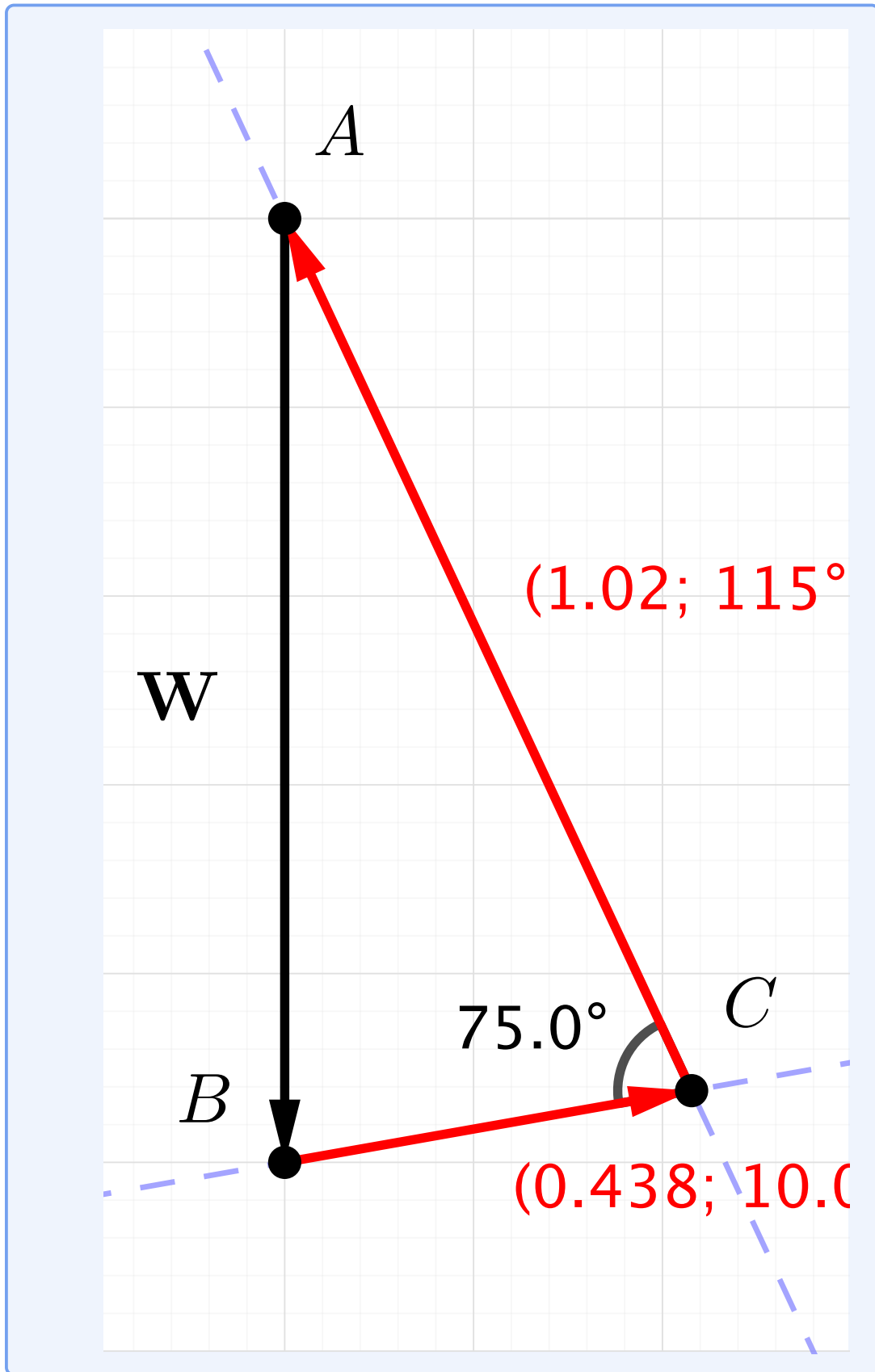



[Live Link](#)

Use the known information to carefully and accurately construct the force triangle.

- (a) Start by placing point A at the origin.
- (b) Draw force \mathbf{W} straight down from A with a length of 1, and place point B at its tip. The length of this vector represents the weight.
- (c) We know the direction of force \mathbf{P} but not its magnitude. For now, just draw line BC passing through point B with an angle of 10° from the horizontal.
- (d) Similarly we know force \mathbf{N} acts at 25° from vertical because it is perpendicular to the inclined surface, and it will close the triangle. So draw line CA passing through point A and at a 25° angle from the y axis.
- (e) Call the point where lines BC and CA intersect point C . Points A , B , and C define the force triangle.
- (f) Now draw force \mathbf{P} from point B to point C , and
- (g) Draw force \mathbf{N} from point C back to point A .

Can you prove from the geometry of the triangle that angle BCA is 75° ?

5. Results.

In steps 6 and 7, Geogebra tells us that $\mathbf{p} = (0.438; 10.0^\circ)$ which means force P is 0.438 units long with a direction of 10° , similarly $\mathbf{n} = (1.02; 115^\circ)$ means N is 1.02 units long at 115° . These angles are measured counter-clockwise from the positive x axis.

These are not the answers we are looking for, but we're close. Remember that for this diagram, our scale is

$$1 \text{ unit} = 100 \text{ lbs,}$$

so scaling the lengths of \mathbf{p} and \mathbf{n} by this factor gives

$$\begin{aligned} P &= (0.438 \text{ unit})(100 \text{ lb/ unit}) \\ &= 43.8 \text{ lb at } 10^\circ \angle \\ N &= (1.02 \text{ unit})(100 \text{ lb/ unit}) \\ &= 102 \text{ lb at } 115^\circ \angle \end{aligned}$$

If you use technology such as Geogebra, as we did here, or CAD software to draw the force triangle, it will accurately produce the solution.

If technology isn't available to you, such as during an exam, you can still use a ruler and protractor to draw the force triangle, but your results will only be as accurate as your diagram. In the best case, using a sharp pencil and carefully measuring lengths and angles, you can only expect about two significant digits of accuracy from a hand-drawn triangle. Nevertheless, even a roughly drawn triangle can give you an idea of the correct answers and be used to check your work after you use another method to solve the problem.

3.4.4 Trigonometric Method

The general approach for solving particle equilibrium problems using the trigonometric method is to:

1. Draw and label a free-body diagram.
2. Rearrange the forces into a force triangle and label it.
3. Identify the knowns and unknowns.
4. Use trigonometry to find the unknown sides or angles of the triangle.

There must be no more than two unknowns to use this method, which may be either magnitudes or directions. During the problem setup, you will probably need to use the geometry of the situation to find one or more angles.

If the force triangle has a right angle you can use [Section B.2](#) to find the unknown values, but in most cases, the triangle will be oblique and you will need to use either or both of the [Law of Sines](#) or the [Law of Cosines](#) to find the sides or angles.

Example 3.4.4 Cargo Boom.

A 24 kN crate is being lowered into the cargo hold of a ship. Boom AB is 20 m long and acts at a 40° angle from kingpost AC . The boom is held in this position by topping lift BC which has a 1:4 slope.

Determine the forces in the boom and in the topping lift.

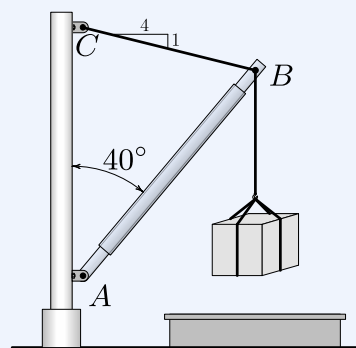

Solution.1. *Draw diagrams.*

Start by identifying the particle and drawing a free-body diagram. The particle in this case is point B at the end of the boom because it is the point where all three forces intersect. Let T be the tension of the topping lift, C be the force in the boom, and W be the weight of the load. Let α and β be the angles that forces T and C make with the horizontal.

Rearrange the forces acting on point B to form a force triangle as was done in the previous example.

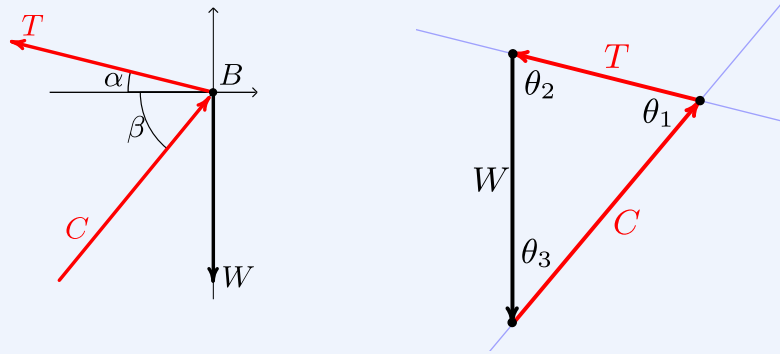
2. *Find angles.*

Angle α can be found from the slope of the topping lift.

$$\alpha = \tan^{-1} \left(\frac{1}{4} \right) = 14.0^\circ.$$

Angle β is the complement of the 40° angle the boom makes with the vertical kingpost.

$$\beta = 90^\circ - 40^\circ = 50^\circ$$

Use these values to find the three angles in the force triangle.

$$\theta_1 = \alpha + \beta = 64.0^\circ$$

$$\theta_2 = 90^\circ - \alpha = 76.0^\circ$$

$$\theta_3 = 90^\circ - \beta = 40.0^\circ$$

3. *Solve force triangle.*

With the angles and one side of the force triangle known, apply the [Law of Sines](#) to find the two unknown sides.

$$\frac{\sin \theta_1}{W} = \frac{\sin \theta_2}{C} = \frac{\sin \theta_3}{T}$$

$$T = W \left(\frac{\sin \theta_3}{\sin \theta_1} \right)$$

$$C = W \left(\frac{\sin \theta_2}{\sin \theta_1} \right)$$

$$T = 24 \text{ kN} \left(\frac{\sin 40.0^\circ}{\sin 64.0^\circ} \right)$$

$$C = 24 \text{ kN} \left(\frac{\sin 76.0^\circ}{\sin 64.0^\circ} \right)$$

$$T = 17.16 \text{ kN}$$

$$C = 25.9 \text{ kN}$$

3.4.5 Scalar Components Method

The general statement of equilibrium of forces, (3.1.1), can be expressed as the sum of forces in the \mathbf{i} , \mathbf{j} and \mathbf{k} directions

$$\Sigma \mathbf{F} = \Sigma F_x \mathbf{i} + \Sigma F_y \mathbf{j} + \Sigma F_z \mathbf{k} = 0. \quad (3.4.1)$$

This statement will only be true if all three coefficients of the unit vectors are themselves equal to zero, leading to this scalar interpretation of the equilibrium equation

$$\Sigma \mathbf{F} = 0 \implies \begin{cases} \Sigma F_x = 0 \\ \Sigma F_y = 0 \\ \Sigma F_z = 0 \end{cases} \quad (\text{three dimensions}). \quad (3.4.2)$$

In other words, the single vector equilibrium equation is equivalent to three independent scalar equations, one for each coordinate direction.

In two-dimensional situations, no forces act in the \mathbf{k} direction leaving just these two equilibrium equations to be satisfied

$$\Sigma \mathbf{F} = 0 \implies \begin{cases} \Sigma F_x = 0 \\ \Sigma F_y = 0 \end{cases} \quad (\text{two-dimensions}). \quad (3.4.3)$$

We will use this equation as the basis for solving two-dimensional particle equilibrium problems in this section and equation (3.4.2) for three-dimensional problems in Section 3.5.

You are undoubtedly familiar with utility poles, which carry electric, cable and telephone lines, but have you ever noticed as you drive down a winding road that the poles will switch from one side of the road to the other and back again? Why is this?

If you consider the forces acting on the top of a pole beside a curving section of road you'll observe that the tensions of the cables produce a net force towards the road. This force is typically opposed by a "guy wire" pulling in the opposite direction which prevents the pole from tipping over due to unbalanced

forces. The power company tries to keep poles beside road segments with convex curvature. If they didn't switch sides, the guy wire for poles at concave curves would extend into the road... which is a poor design.

Example 3.4.5 Utility Pole.

Consider the utility pole next to the road shown below. A top view is shown in the right-hand diagram. If each of the six power lines pulls with a force of 10.0 kN, determine the magnitude of the tension in the guy wire.

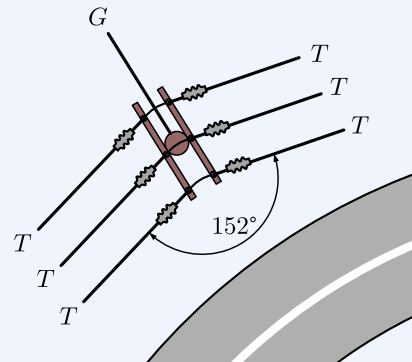

Solution.

1. Assumptions.

A utility pole isn't two-dimensional, but we can solve this problem as if it was by first considering the force components acting in a horizontal plane, and then considering the components in a vertical plane.

It also isn't a concurrent force problem because the lines of action of the forces don't all intersect at a single point. However, we can make it into one by replacing the forces of the three power lines in each direction with a single force three times larger. This is an example of an *equivalent transformation*, a trick engineers use frequently to turn complex situations into simpler ones. It works here because all the tensions are equal, and the outside wires are equidistant from the center wire. You must be careful to justify all equivalent transformations because they will lead to errors if they are not applied correctly. Equivalent transformations will be discussed in greater detail in [Section 4.6](#) later.

2. *Givens.*

$T = 10.0$ kN and 38° and 152° angles.

3. *Free-Body Diagram.*

Begin by drawing a neat, labeled, free-body diagram of the top view of the pole, establishing a coordinate system and indicating the directions of the forces.

Call the tension in one power line T and the tension in the guy wire G . Resolve the the tension of the guy wire into a horizontal component G_h , and a vertical component G_v . Only the horizontal component of G is visible in the top view.

Although it is not necessary, it simplifies this problem considerably to note the symmetry and establish the x axis along the axis of symmetry.

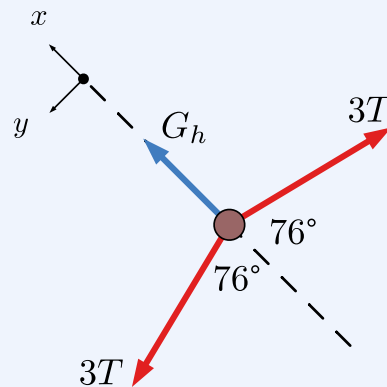
4. *Solution.*

Solve for G_h by applying the equations of equilibrium. The symmetry of this problem means that the ΣF_x equation is sufficient.

$$\begin{aligned}\Sigma F_x &= 0 \\ G_h - 6T_x &= 0 \\ G_h &= 6(T \cos 76^\circ) \\ &= 14.5 \text{ kN}\end{aligned}$$

Once G_h is determined, the tension of the guy wire G is easily found by considering the components of G in the side view. Note that the vertical component G_v tends to compress the pole.

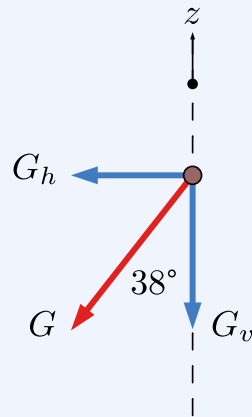

$$\begin{aligned} G_h/G &= \sin 38^\circ \\ G &= G_h/\sin 38^\circ \\ G &= 23.6 \text{ kN} \end{aligned}$$

This problem could have also been solved using the force triangle method. See [Subsection 3.4.3](#).

In the next example we look at the conditions of equilibrium by considering the load and the constraints, rather than taking a global equilibrium approach which considers both the load and reaction forces.

Example 3.4.6 Slider.

Three forces act on a machine part that is free to slide along a vertical, frictionless rod. Forces A and B have a magnitude of 20 N and force C has a magnitude of 30 N. Force B acts α degrees from the horizontal, and force C acts at the same angle from the vertical.

Determine the angle α required for equilibrium, and the magnitude and direction of the reaction force acting on the slider.

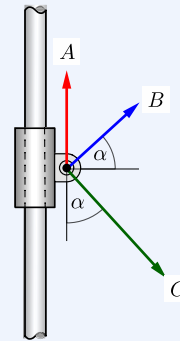

Solution.

1. Givens.

We are given magnitudes of forces $A = 20 \text{ N}$, $B = 20 \text{ N}$, and $C = 30 \text{ N}$. The unknowns are angle α and resultant force R .

2. Procedure.

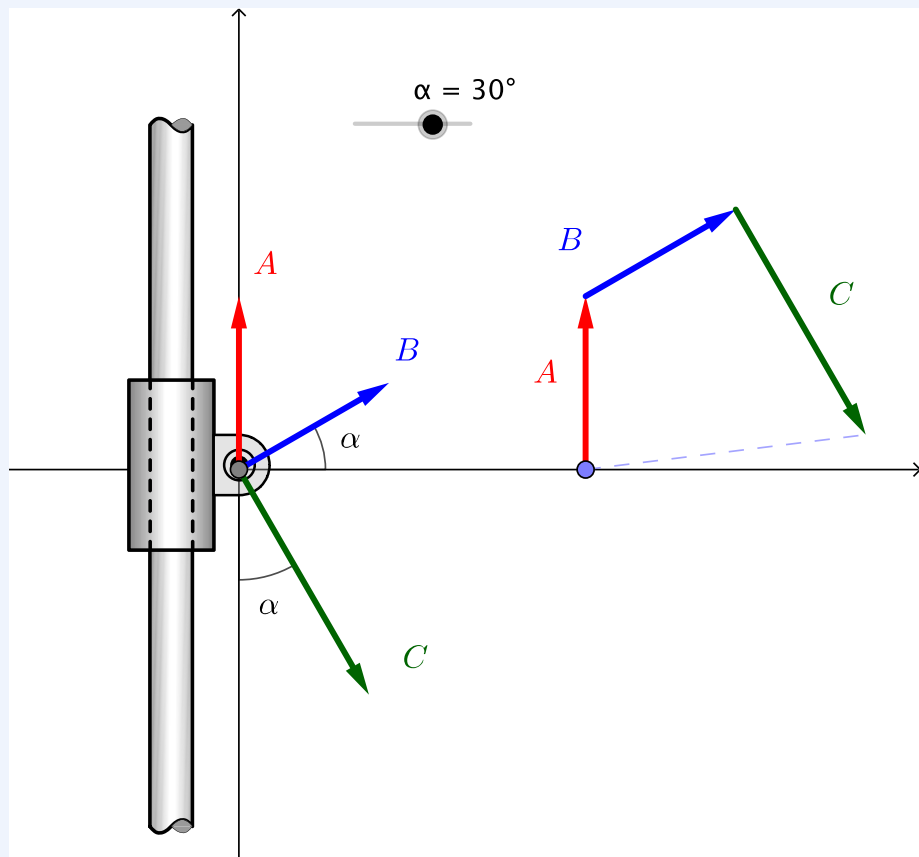

[Live Link](#)

Since the rod is frictionless, it cannot prevent the slider from moving vertically. Consequently, the slider will only be in equilibrium if the resultant of the three load forces is horizontal. Since a horizontal force has no y component, we can establish this equilibrium condition:

$$R_y = \Sigma F_y = A_y + B_y + C_y = 0$$

Inserting the known values into the equilibrium relation and simplifying gives an equation in terms of unknown angle α .

$$\begin{aligned} R_y &= A_y + B_y + C_y = 0 \\ A + B \sin \alpha - C \cos \alpha &= 0 \\ 20 + 20 \sin \alpha - 30 \cos \alpha &= 0 \end{aligned}$$

$$2 + 2 \sin \alpha - 3 \cos \alpha = 0$$

This is a single equation with a single unknown, although it is not particularly easy to solve with algebra. One approach is described at socratic.org. An alternate approach is to use technology to graph the function $y(x) = 2 + 2 \sin x - 3 \cos x$. The roots of this equation correspond to values of α which satisfy the equilibrium condition above. The root occurring closest to $x = 0$ will be the answer corresponding to our problem, in this case $\alpha = 22.62^\circ$ which you can verify by plugging it back into the equilibrium equation. Note that -90° also satisfies this equation, but it is not the solution we are looking for.

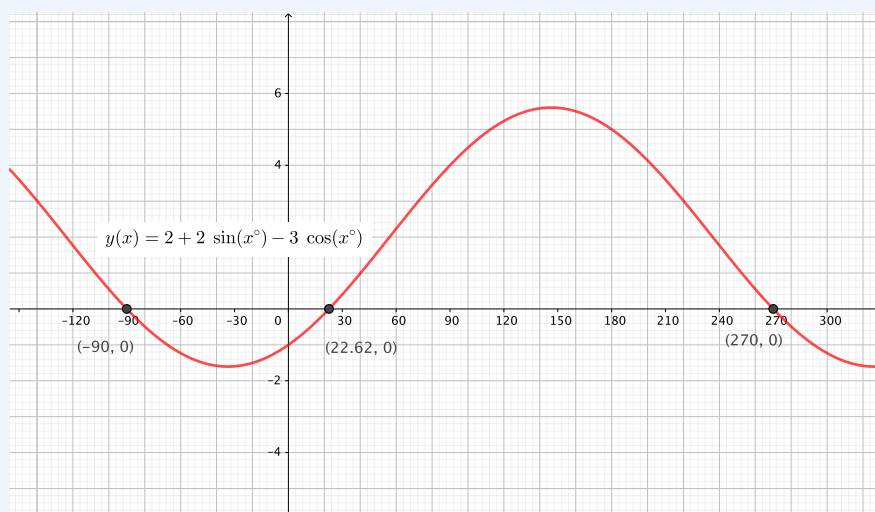

Once α is known, we can find the reaction force by adding the x components of A , B , and C .

$$\begin{aligned} R_x &= A_x + B_x + C_x \\ &= A + B \cos \alpha + C \sin \alpha \\ &= 0 + 20 \cos(22.62^\circ) + 30 \sin(22.62^\circ) \\ &= 30.00 \text{ N} \end{aligned}$$

The resultant force \mathbf{R} is the vector sum of R_x and R_y , but in this situation R_y is zero, so the resultant acts purely to the right with a magnitude of R_x .

$$\mathbf{R} = 30.00 \text{ N} \rightarrow .$$

Note that this value is the **resultant** force, i.e. the net force applied to the slider by \mathbf{A} , \mathbf{B} , and \mathbf{C} . However, the question asks for the

reaction force, which is the force required for equilibrium. The reaction is equal and opposite to the resultant.

$$\mathbf{R}' = -\mathbf{R} = 30.00 \text{ N } \leftarrow$$

The next example demonstrates how rotating the coordinate system can simplify the solution. In the first solution, the standard orientation of the x and y axes is chosen, and in the second the coordinate system is rotated to align with one of the unknowns, which enables the solution to be found without solving simultaneous equations.

Example 3.4.7 Roller.

A lawn roller which weighs 160 lb is being pulled up a 10° slope at a constant velocity. Determine the required pulling force P .

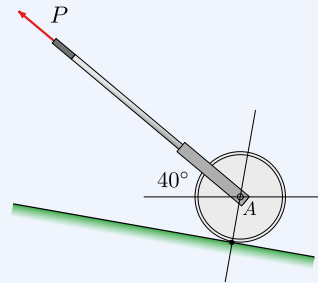

Solution 1.

1. Strategy.

- Select a coordinate system, in this case, horizontal and vertical.
- Draw a free-body diagram
- Solve the equations of equilibrium using the scalar approach.

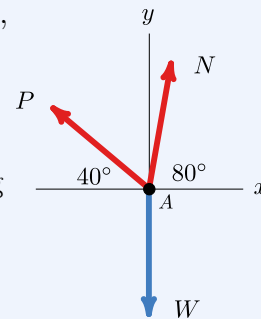

2. Procedure.

$$\begin{aligned} \Sigma F_x &= 0 & \Sigma F_y &= 0 \\ -P_x + N_x &= 0 & P_y + N_y &= 0 \\ N \cos 80^\circ &= P \cos 40^\circ & P \sin 40^\circ + N \sin 80^\circ &= W \\ N &= P \left(\frac{0.766}{0.174} \right) & 0.643P + 0.985N &= 160 \text{ lb} \end{aligned}$$

Solving simultaneously for P

$$0.643P + 0.985(4.40P) = 160 \text{ lb}$$

$$4.98P = 160 \text{ lb}$$

$$P = 32.1 \text{ lb}$$

Solution 2.1. *Strategy.*

- (a) Rotate the standard coordinate system 10° clockwise to align the new y' axis with force N .
- (b) Draw a free-body diagram and calculate the angles between the forces and the rotated coordinate system.
- (c) Solve for force P directly.

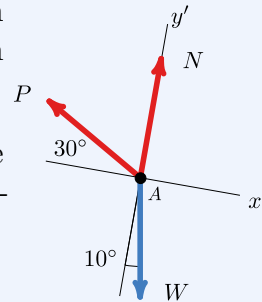
2. *Procedure.*

$$\Sigma F_{x'} = 0$$

$$-P_{x'} + W_{x'} = 0$$

$$P \cos 30^\circ = W \sin 10^\circ$$

$$P = 160 \text{ lb} \left(\frac{0.1736}{0.866} \right)$$

$$P = 32.1 \text{ lb}$$

3.4.6 Multi-Particle Equilibrium

When two or more particles interact with each other there will always be common forces between them as a result of Newton's Third Law, the action-reaction principle.

Consider the two boxes with weights W_1 and W_2 connected to each other and the ceiling shown in the interactive diagram. Position one shows the physical arrangement of the objects, position two shows their free-body diagrams, and position three shows simplified free-body diagrams where the objects are represented by points. The boxes were freed by replacing the cables with tension forces T_A and T_B .

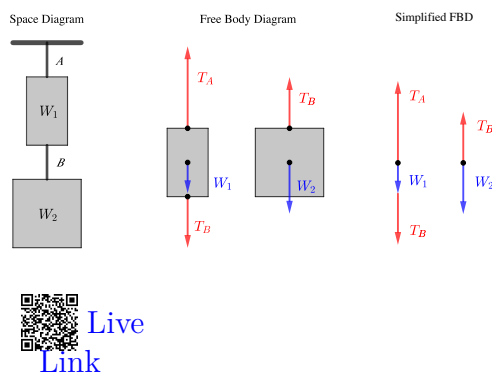

Figure 3.4.8 Two suspended weights

From the free-body diagrams you can see that cable B only supports the weight of the bottom box, while cable A and the ceiling support the combined weight. The tension T_B is common to both diagrams. Recognizing the common force is the key to solving multi-particle equilibrium problems.

Example 3.4.9 Two hanging weights.

A 100 N weight W is supported by cable $ABCD$. There is a frictionless pulley at B and the hook is firmly attached to the cable at point C .

What is the magnitude and direction of force \mathbf{P} required to hold the system in the position shown?

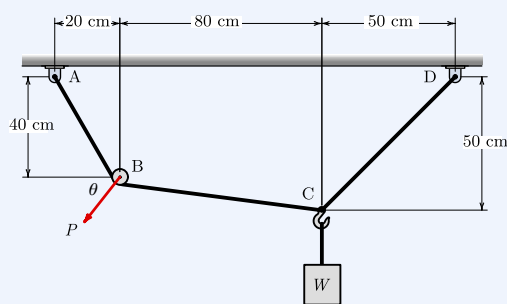

Hint. The particles are points B and C . The common force is the tension in rope segment BC .

Solution.

1. *Strategy.*

Following the [General Procedure](#) we identify the particles as points A and B , and draw free-body diagrams of each. We label the rope tensions A , C , and D for the endpoints of the rope segments, and label the angles of the forces α , β , and ϕ . We will use the standard Cartesian coordinate system and use the [scalar components method](#).

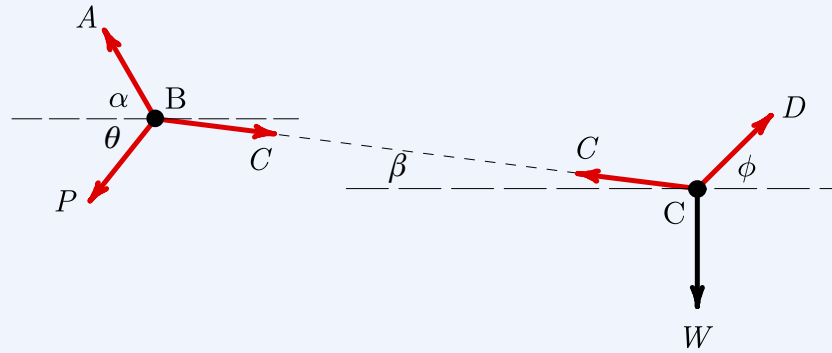

Weight W was given, and we can easily find angles α , β , and ϕ so the knowns are:

$$W = 100 \text{ N}$$

$$\alpha = \tan^{-1} \left(\frac{40}{20} \right) = 63.4^\circ$$

$$\beta = \tan^{-1} \left(\frac{10}{80} \right) = 7.13^\circ$$

$$\phi = \tan^{-1} \left(\frac{50}{50} \right) = 45^\circ$$

Counting unknowns we find that there are two on the free-body diagram of particle C (C and D), but four on particle B , (AC , P and θ).

Two unknowns on particle C means it is solvable since there are two [equilibrium equations](#) available, so we begin there.

2. Solve Particle C .

$$\begin{aligned} \Sigma F_x &= 0 & \Sigma F_y &= 0 \\ -C_x + D_x &= 0 & C_y + D_y - W &= 0 \\ C \cos \beta &= D \cos \phi & C \sin \beta + D \sin \phi &= W \\ C &= D \left(\frac{\cos 45^\circ}{\cos 7.13^\circ} \right) & C \sin 7.13^\circ + D \sin 45^\circ &= 100 \text{ N} \\ C &= 0.713D & 0.124C + 0.707D &= 100 \text{ N} \end{aligned}$$

Solving these two equations simultaneously gives

$$C = 89.6 \text{ N}$$

$$D = 125.7 \text{ N}$$

With particle C solved, we can use the results to solve particle B . There are three unknowns remaining, tension A , magnitude P , and direction θ . Unfortunately, we still only have two available equilibrium equations. When you find yourself in this situation with more unknowns than equations, it generally means that you are missing something. In this case, it is the pulley. When a cable wraps around a frictionless pulley the tension doesn't change. The missing information is that $A = C$. Knowing this, the magnitude and direction of force \mathbf{P} can be determined.

Because $A = C$, the free-body diagram of particle B is symmetric, and the technique used in [Example 3.4.5](#) to rotate the coordinate system could be applied here.

3. Solve Particle B .

Referring to the FBD for particle B we can write these equations.

$$\begin{aligned} \Sigma F_x &= 0 & \Sigma F_y &= 0 \\ -A_x - P_x + C_x &= 0 & A_y - P_y - C_y &= 0 \\ P \cos \theta &= C \cos \beta - A \cos \alpha & P \sin \theta &= A \sin \alpha - C \sin \beta \end{aligned}$$

Since $A = C = 89.6 \text{ N}$, substituting and solving simultaneously gives

$$\begin{aligned} P \cos \theta &= 48.8 \text{ N} & P \sin \theta &= 69.0 \text{ N} \\ P &= 84.5 \text{ N} & \theta &= 54.7^\circ \end{aligned}$$

These are the magnitude and direction of vector \mathbf{P} . If you wish, you can express \mathbf{P} in terms of its scalar components. The negative signs on the components have been applied by hand since \mathbf{P} points down and to the left.

$$\begin{aligned} \mathbf{P} &= \langle -P \cos \theta, -P \sin \theta \rangle \\ &= \langle -48.8 \text{ N}, -69.0 \text{ N} \rangle \end{aligned}$$

3.5 3D Particle Equilibrium

The world we live in has three dimensions. One and two-dimensional textbook problems have been useful for learning the principles of engineering mechanics, but to model real-world problems we will have to consider all three.

Fortunately, all the principles you have learned so far still apply, but many students have difficulty visualizing three-dimensional problems drawn on two-dimensional paper and the mathematics becomes a bit harder. It is especially important to have good diagrams and keep your work neat and organized to avoid errors.

3.5.1 Three-Dimensional Coordinate Frame

We need a coordinate frame for three dimensions, just as we did in two dimensions, so we add a third orthogonal axis z to our existing two-dimensional frame.

For equilibrium of a particle, usually the origin of the coordinate frame is at the particle, the x axis is horizontal, and the y axis is vertical just as in a two-dimensional situation. The orientation of the z axis is determined by the **right-hand rule**. Using your *right hand*, put your palm at the origin and point your fingers along the positive x axis. Then curl your fingers towards the positive y axis. Your thumb will point in the direction of the positive z axis. For example, in the plane of the page with the positive x axis horizontal and to the right and the positive y axis vertical and upwards, the positive z axis will point *towards* you out of the page. Remember that the three axes are mutually perpendicular, i.e. each axis is perpendicular to both of the others. The right-hand rule is important in many aspects of engineering, so make sure that you understand how it works. Mistakes will lead to sign errors.

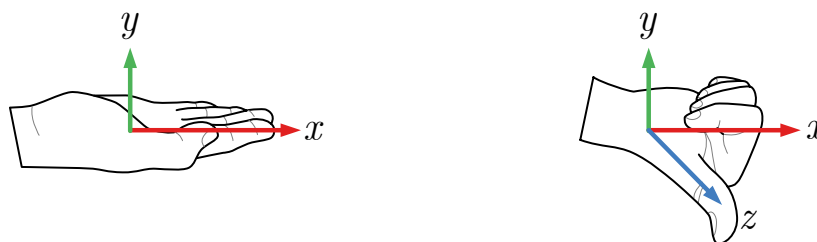

Figure 3.5.1 Point-and-curl right-hand rule technique.

3.5.2 Free-Body Diagrams

As we did before, we begin our analysis by drawing a free-body diagram that shows all forces and moments acting on the object of interest. Drawing a FBD in three dimensions can be difficult. It is sometimes hard to see things in three dimensions when they are drawn on a two-dimensional sheet. Consequently, it is important to carefully label vectors and angles, but not to clutter up the diagram with too much and/or unnecessary information. When working in two

dimensions, you only need one angle to determine the direction of the vector, but when working in three dimensions you need two or three angles.

3.5.3 Angles

As stated above, when working in three dimensions you need three angles to determine the direction of the vector, namely, the angle with respect to the x axis, the angle with respect to the y axis and the angle with respect to the z axis. The three angles mentioned above are not necessarily located in any of the coordinate planes. Think of it this way — three points determine a plane, and in this case, the three points are: the origin, the tip of the vector, and a point on an axis. The plane made by those three points is not necessarily the xy , yz , or xz plane. It is most likely a “tilted” plane.

As you learned in [Subsection 2.4.2](#), one way to quantify the direction of a vector is with direction cosine angles. These direction cosine angles are measured from the positive x , y , and z axes and are often labeled θ_x , θ_y , and θ_z , respectively.

As with two dimensions, angles can be determined from geometry — a distance vector going in the same direction as the force vector. This is the three-dimensional equivalent of similar triangles that you used in the two-dimensional problems.

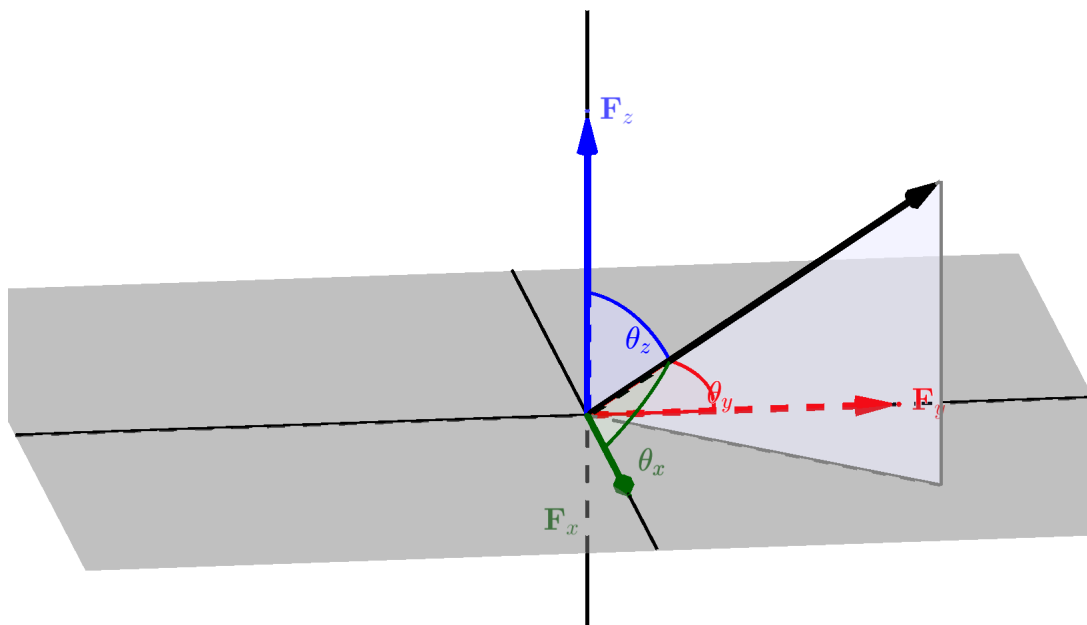

[Live Link](#)

Figure 3.5.2 Direction Cosine Angles

If you know that the line of action of a force vector goes between two points,

then you can use the distance vector that goes from one point to the other to determine the angles.

Let's suppose that the line of action goes through two points A and B , and the direction of the force is from A towards B . The first step in determining the three angles is to write the distance vector from point A towards point B . Let's call this vector \mathbf{r}_{AB} . Starting at point A , you need to determine how to get to point B by moving in each of the three directions. Ask yourself: to get from point A to point B do I have to move in the x direction? If so, how far do I have to travel? This becomes the x component of the vector \mathbf{r}_{AB} namely r_{AB_x} . Next, to get from point A to point B how far do I move in y direction? This distance is r_{AB_y} . Finally, to get from point A to point B how far do I move in the z -direction? This distance is r_{AB_z} .

When writing these scalar components pay attention to which way you move along the axes. If you travel toward the positive end of an axis, the corresponding scalar component gets a positive sign. Travel towards the negative end results in a negative sign. The sign is important.

Once you have determined the components of the distance vector r_{AB} , you can determine the total distance from point A to B using the [three-dimensional Pythagorean Theorem](#)

$$r_{AB} = \sqrt{(r_{AB_x})^2 + (r_{AB_y})^2 + (r_{AB_z})^2} \quad (3.5.1)$$

Lastly, the angles are determined by the direction cosines, namely

$$\cos \theta_x = \frac{r_{AB_x}}{r_{AB}} \quad \cos \theta_y = \frac{r_{AB_y}}{r_{AB}} \quad \cos \theta_z = \frac{r_{AB_z}}{r_{AB}}$$

Since the force vector has the same line of action as the distance vector, by the three-dimensional version of similar triangles,

$$\frac{r_{AB_x}}{r_{AB}} = \frac{F_x}{F} \quad \frac{r_{AB_y}}{r_{AB}} = \frac{F_y}{F} \quad \frac{r_{AB_z}}{r_{AB}} = \frac{F_z}{F}$$

. So,

$$F_x = \left(\frac{r_{AB_x}}{r_{AB}} \right) F \quad F_y = \left(\frac{r_{AB_y}}{r_{AB}} \right) F \quad F_z = \left(\frac{r_{AB_z}}{r_{AB}} \right) F$$

Now, that is a bit of math there, but the important things to remember are:

- You can use three angles to determine the direction of a force in three dimensions.
- You can use the geometry to get them from a distance vector that lies along the line of action of the force.

The three direction cosine angles are not mutually independent. From (3.5.1) you can easily show that

$$\cos^2 \theta_x + \cos^2 \theta_y + \cos^2 \theta_z = 1, \quad (3.5.2)$$

so if you know two direction cosine angles you can find the third from this relationship.

3.5.4 General Procedure

The general procedure for solving three-dimensional particle equilibrium is essentially the same as for two-dimensional particle equilibrium using the components method. The major differences are that you must carefully find each vector component using the techniques from [Section 2.4](#). The process follows the same five-step method for creating a free-body diagram, followed by steps to solve your equilibrium equations.

Draw a Free-body Diagram:

1. *Select and isolate the particle.* The “free-body” in free-body diagram means that a concurrent force particle or connection must be isolated from the supports that are physically holding it in place. This means creating a separate free-body diagram from your problem sketch.
2. *Establish a coordinate system.* Draw a right-handed coordinate system to use as a reference for your equilibrium equations. Look ahead and select a coordinate system that minimizes the number of force components. This will simplify your vector algebra. The choice is technically arbitrary, but a good choice will simplify your calculations and reduce your effort.
3. *Identify all loads.* Add force vectors to your free-body diagram representing each applied load pushing or pulling the body, in addition to the body’s weight, if it is non-negligible. If a force vector has a known direction, draw it. If its direction is unknown, assume one, and your later algebra will check your assumption. Every vector should have a descriptive variable name and a clear arrowhead indicating its direction.
4. *Identify all reactions.* Reactions represent the resistance of the physical supports you cut away by isolating the body in step 1. All particle supports are some type of two-force members with tension or compression reaction forces. These reactions will all be concurrent with the body loads from Step 2. Label each reaction with a descriptive variable name and a clear arrowhead. Again, if a vector’s direction is unknown, just assume one.
5. *Label the diagram.* Verify that every dimension, angle, force, and moment is labeled with either a value or a symbolic name if the value is unknown. In our eyes, dimensioning is optional. Having the information needed for your calculations is helpful, but don’t clutter the diagram up with unneeded details. Your final free-body diagram should be a stand-alone presentation and is the basis of your equilibrium equations.

Create and Solve Equilibrium Equations

1. *Break vectors into components.* Compute each force’s x , y , and z components using the tools outlined in [Section 2.4](#). While the components in two-dimensional problems can often be found with right triangle trigonometry, three-dimensional problems often use unit vectors.

2. *Write equilibrium equations.* Now represent your free-body diagram as equilibrium equations. For a three-dimensional particle equilibrium problem, you can have up to three force equilibrium equations corresponding to a force balance in the three independent x , y , and z directions. Each equation should start with the governing equation, like $\Sigma F_x = 0$.
3. *Count knowns and unknowns.* At this point, you should have at most three unknowns remaining. If you have over three, reread the problem and look for overlooked information.
4. *Solve for unknowns.* Use algebra to simplify the equilibrium equations and solve for unknowns. With multiple unknowns scattered across multiple equations, linear algebra may be more efficient than substitution. Assume that all answers have units - unless you prove that they don't. Finally, underline or box your answers.
5. *Check your work.* If you add the components of the forces, do they add to zero? Do the results seem reasonable given the situation? Have you included appropriate units?

Now let's see how that process looks on an example problem.

Example 3.5.3 Balloon.

A hot air balloon 30 ft above the ground is tethered by three cables as shown in the diagram.

If the balloon is pulling upwards with a force of 900 lb, what is the tension in each of the three cables?

The grid lines on the ground plane are spaced 10 ft apart.

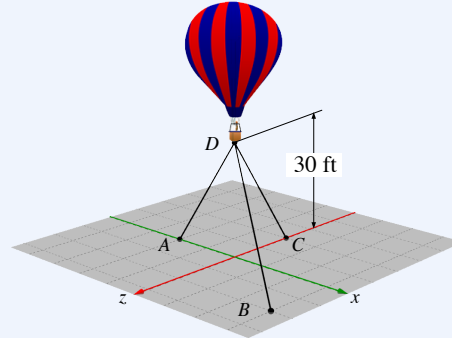

Solution.

1. *Strategy.*

The three tensions are the unknowns which we can find by applying the three equilibrium equations.

We'll establish a coordinate system with the origin directly below the balloon and the y axis vertical, then draw and label a free-body diagram.

Next we'll use the given information to find two points on each line of action to find the components of each force in terms of the unknowns.

When the x , y and z components of all forces can be expressed in terms of known values, the equilibrium equations can be solved.

2. Geometry.

From the diagram, the coordinates of the points are

$$A = (-20, 0, 0) \quad B = (30, 0, 20) \quad C = (0, 0, -20) \quad D = (0, 30, 0)$$

Use the point coordinates to find the x , y and z components of the forces.

$$\begin{aligned} A_x &= \frac{-20}{L_A}A & A_y &= \frac{-30}{L_A}A & A_z &= \frac{0}{L_A}A \\ B_x &= \frac{30}{L_B}B & B_y &= \frac{-30}{L_B}B & B_z &= \frac{20}{L_B}B \\ C_x &= \frac{0}{L_C}C & C_y &= \frac{-30}{L_C}C & C_z &= \frac{-20}{L_C}C \end{aligned}$$

Where L_A , L_B and L_C are the lengths of the three cables found with the [distance formula](#).

$$\begin{aligned} L_A &= \sqrt{(-20)^2 + (-30)^2 + 0^2} & &= 36.1 \text{ ft} \\ L_B &= \sqrt{30^2 + (-30)^2 + 20^2} & &= 46.9 \text{ ft} \\ L_C &= \sqrt{0^2 + (-30)^2 + (-20)^2} & &= 36.1 \text{ ft} \end{aligned}$$

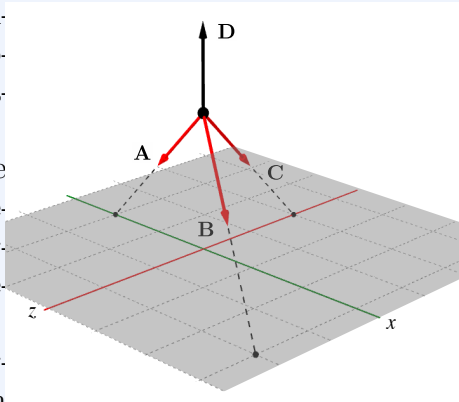

3. *Equilibrium Equations.*

Applying the three equations of equilibrium yields three equations in terms of the three unknown tensions.

$$\begin{aligned}\Sigma F_x &= 0 \\ A_x + B_x + C_x &= 0 \\ -\frac{20}{36.1}A + \frac{30}{46.9}B + 0C &= 0 \\ A &= 1.153 B\end{aligned}\tag{1}$$

$$\begin{aligned}\Sigma F_z &= 0 \\ A_z + B_z + C_z &= 0 \\ 0A + \frac{20}{46.9}B - \frac{20}{36.1}C &= 0 \\ C &= 0.769 B\end{aligned}\tag{2}$$

$$\begin{aligned}\Sigma F_y &= 0 \\ A_y + B_y + C_y + D &= 0 \\ -\frac{30}{36.1}A - \frac{30}{46.9}B - \frac{30}{36.1}C + 900 &= 0 \\ 0.832 A + 0.640 B + 0.832 C &= 900 \text{ lb}\end{aligned}\tag{3}$$

Solving these equations simultaneously yields the answers we are seeking. One way to do this is to substitute equations (1) and (2) into (3) to eliminate A and C and solve the resulting equation for B .

$$\begin{aligned}0.832(1.153 B) + 0.640 B + 0.832(0.769 B) &= 900 \text{ lb} \\ 2.24B &= 900 \text{ lb} \\ B &= 402 \text{ lb}\end{aligned}$$

With B known, substitute it into equations (1) and (2) to find A and C .

$$\begin{array}{ll} A = 1.153 B & C = 0.769 B \\ = 464 \text{ lb} & = 309 \text{ lb} \end{array}$$

Example 3.5.4 Skycam.

The skycam at Stanford University Stadium has a mass of 20 kg and is supported by three cables as shown. Assuming that it is currently in equilibrium, find the tension in each of the three supporting cables.

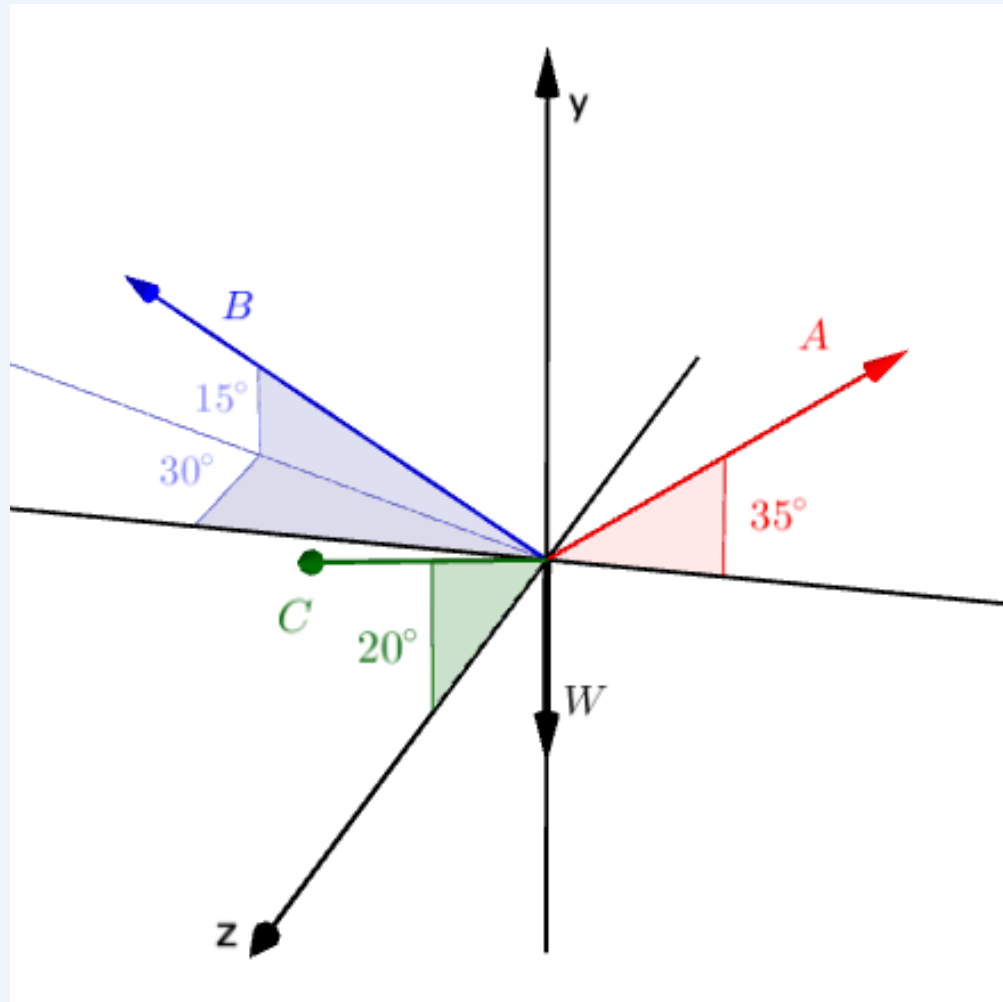

[Live Link](#)

Solution. In this situation, the directions of all four forces are specified by the angles in the free-body diagram, and the magnitude of the weight

is known. The three unknowns are the magnitudes of forces **A**, **B**, and **C**.

$$W = mg = 20 \text{ kg } 9.81 \text{ m/s}^2 = 196.2 \text{ N}$$

We will first find unit vectors in the directions of the four forces by inspection of the free-body diagram. This step requires visualizing the component's unit vectors and determining the angles each makes with the coordinate axis.

$$\hat{\mathbf{W}} = \langle 0, -1, 0 \rangle$$

$$\hat{\mathbf{A}} = \langle \cos 35^\circ, \cos 55^\circ, 0 \rangle$$

$$\hat{\mathbf{B}} = \langle -\cos 15^\circ \cos 30^\circ, \cos 75^\circ, -\cos 15^\circ \cos 60^\circ \rangle$$

$$\hat{\mathbf{C}} = \langle 0, \cos 70^\circ, \cos 20^\circ \rangle$$

Particle equilibrium requires that $\sum \mathbf{F} = 0$.

$$A \hat{\mathbf{A}} + B \hat{\mathbf{B}} + C \hat{\mathbf{C}} = -W \hat{\mathbf{W}}$$

This is a 3×3 system of three simultaneous equations, one for each coordinate direction, which needs to be solved for A , B , and C .

$$A \cos 35^\circ - B \cos 15^\circ \cos 30^\circ + 0 = 0 \quad (\Sigma F_x = 0)$$

$$A \cos 55^\circ + B \cos 75^\circ + C \cos 70^\circ = 196.2 \text{ N} \quad (\Sigma F_y = 0)$$

$$0 - B \cos 15^\circ \cos 60^\circ + C \cos 20^\circ = 0 \quad (\Sigma F_z = 0)$$

These can be solved by any method you choose. Here we will use Sage. Evaluating the coefficients and expressing the equations in matrix form gives

$$\begin{bmatrix} 0.819 & -0.837 & 0 \\ 0.574 & 0.259 & 0.342 \\ 0 & -0.482 & 0.940 \end{bmatrix} \begin{bmatrix} A \\ B \\ C \end{bmatrix} = \begin{bmatrix} 0 \\ 196.2 \text{ N} \\ 0 \end{bmatrix}.$$

This is an equation in the form

$$[A][x] = [B].$$

Entering the coefficient matrices into Sage.

```
A = Matrix([[0.819, -0.837, 0], [0.574, 0.259, 0.342], [0, -0.482, 0.940]])
B = vector([0, 196.2, 0])
x = A.solve_right(B)
x
```

```
(196.391530042156, 192.168056277808, 98.5372373679827)
```

After evaluating, we learn that

$$A = 196.4 \text{ N} \quad B = 192.2 \text{ N} \quad C = 98.5 \text{ N}$$

3.6 Exercises (Ch. 3)

Chapter 3 Exercises

Particle Equilibrium	0/192
Equilibrium equation method	0/20 Not attempted
Particle Equilibrium: Use slopes to find components	0/20 Not attempted
Four forces	0/20 Not attempted
Block on Incline	0/10 Not attempted
Hanging weight	0/22 Not attempted
Ball in a trough	0/20 Not attempted
Rope and pulley	0/20 Not attempted
3D Equilibrium: Hanging Plate	0/60 Not attempted
Multi-particle Equilibrium	0/60
Two suspended loads	0/20 Not attempted
Blocks on Inclines	0/10 Not attempted
Cylinders in a trough	0/30 Not attempted

Display options

Done

Created using Numbas v9.1, developed by [Newcastle University](#)

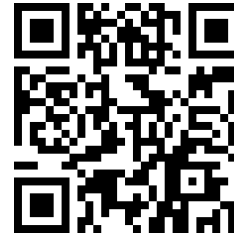

Standalone
In Context

Chapter 4

Moments and Static Equivalence

When a force acts on a body, it can potentially produce two effects: translation of the body in the direction of the force, and rotation of the body about an axis. For a body in equilibrium, we say that forces have a *tendency* to produce translation or rotation since no actual acceleration or motion occurs.

The rotational tendency of a force is the subject of this chapter. Engineers refer to this rotational tendency as a **moment**, short for “moment of a force.” You may remember using the term **torque** for the same quantity in physics. Physicists use *torque* specifically for the moment of a force, and *moment* for the product of *any* physical quantity with distance. To an engineer, a torque refers specifically to a moment about the long axis of an object that produces twisting and torsional stresses.

A wrench provides a familiar example. A force \mathbf{F} applied to the handle of a wrench, as shown in [Figure 4.0.1](#), creates a moment \mathbf{M}_A about an axis perpendicular to the page through the center of the nut at point A . The \mathbf{M} is bold because moments are vector quantities, and the subscript A indicates the axis or center of rotation. The direction of the moment can be either clockwise or counterclockwise, depending on how the force is applied. If the nut is frozen, no actual rotation occurs, but the force still produces a tendency to rotate it, i.e. a moment.

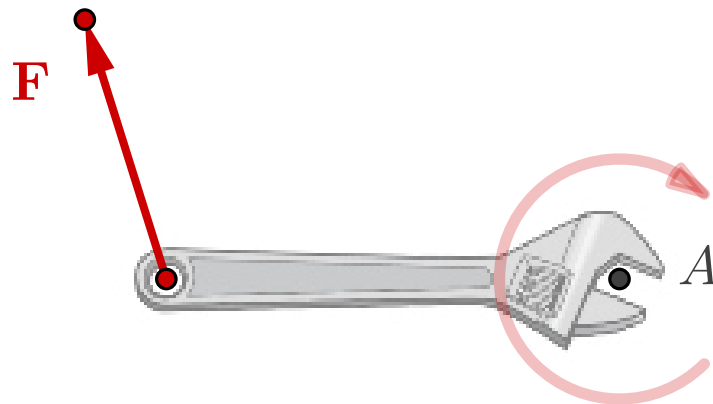

[Live Link](#)

Figure 4.0.1 A moment M_A is created about point A by force F .

4.1 Moment of Force

A moment of force, or torque, is a measure of the tendency of that force to rotate a body about a selected point or axis, called the **moment center**. This tendency increases with the magnitude of the force, and also with the distance between the line of action of the force and the moment center.

Moments are vector quantities, so they have magnitude and direction and obey all the rules of vector arithmetic, even dot and cross products, described in [Chapter 2](#).

4.1.1 Magnitude of a Moment

The magnitude of a moment describes how hard it turns, in the same way that the magnitude of a force describes how hard it pushes or pulls. When you turn a door knob, the magnitude of the moment is how hard you twist the knob.

The magnitude of a moment is found by multiplying the magnitude of the force by the distance between the line of action of the force and the center of

rotation, as illustrated in [Figure 4.1.1](#). This distance called the **moment arm** or the **perpendicular distance**, d_{\perp} .

$$M = Fd_{\perp}. \quad (4.1.1)$$

Since the moment is the product of the force's magnitude and the perpendicular distance, the closer the point is to the force's line of action, the smaller the moment. If the point lies upon the force's line of action, then the moment arm is zero, making the moment zero as well. But notice that a force may be slid along its line-of-action without changing the moment, because neither the magnitude of the force nor the moment arm changes. The magnitude of a moment is a positive quantity regardless of whether it produces a clockwise or counterclockwise tendency.

Moments are the product of a force with a distance, so they have units of [force] \times [distance] such as N-m or ft-lb.

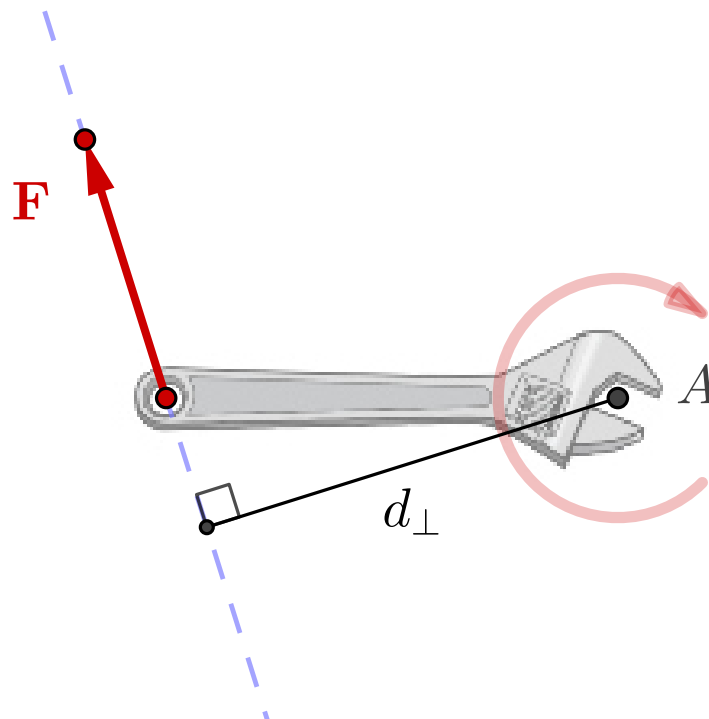

[Live Link](#)

Figure 4.1.1 Definition of the moment, $M = Fd_{\perp}$.

Example 4.1.2

A mobile crane is used to raise a 500 lb load of building materials. Boom AC is 40 ft long and the tension of the boom pendant AB is 1500 lb.

Use the definition of the moment (4.1.1) to determine the magnitude and direction of:

- M_1 , the moment about point C caused by the load, W .
- M_2 , the moment about point C caused by tension T .

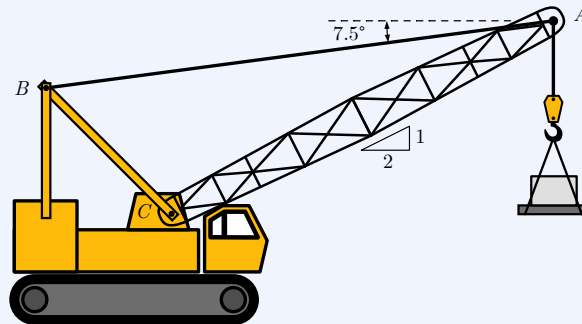

Solution.

- Given: $W = 500$ lb, $T = 1500$ lb, boom length $AC = 40$ ft.
- Sketch right triangles containing the perpendicular distances d_1 and d_2 from point C to the lines of action of W and T .

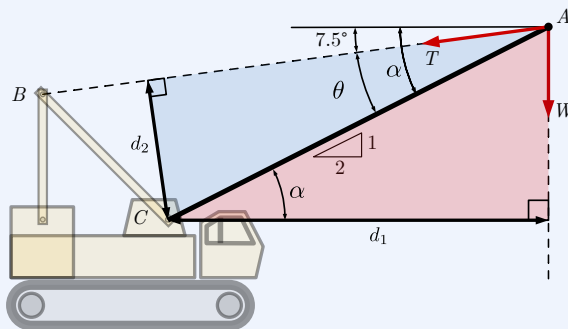

- Find angles in the right triangles.

$$\alpha = \tan^{-1}(1/2) = 26.6^\circ$$

$$\theta = \alpha - 7.5^\circ = 19.1^\circ$$

- Use trigonometry to find the perpendicular distances.

$$d_1 = 40 \cos \alpha = 35.8 \text{ ft}$$

$$d_2 = 40 \sin \theta = 13.06 \text{ ft}$$

- Apply the definition of the moment (4.1.1), and solve for the moments.

$$M_1 = Wd_1 = (500 \text{ lb})(35.8 \text{ ft}) = 17,885 \text{ ft}\cdot\text{lb}$$

$$M_2 = Td_2 = (1500 \text{ lb})(13.06 \text{ ft}) = 19,590 \text{ ft}\cdot\text{lb}$$

By inspection, we see that the tension produces a counterclockwise rotation and the load produces a clockwise rotation. Counterclockwise moment M_2 is greater than the clockwise moment M_1 because the boom pendant must also support the weight of the boom, which we have not accounted for.

As we will see in the next section, counterclockwise moments indicate a positive scalar moment in two dimensions, and a vector that points in the $+\mathbf{k}$ direction in three.

Example 4.1.3

The bent column ABC is firmly fixed to the ground at A . Determine the magnitude and direction of the moment about point A produced by the 400 N force applied at C .

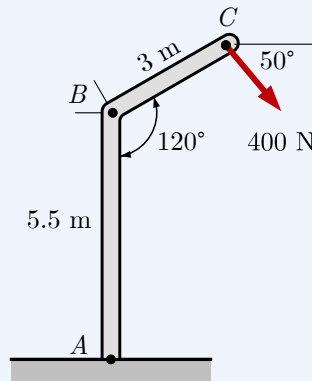

Solution. This problem is similar to the previous example, but the geometry required to find the perpendicular distance is slightly more difficult.

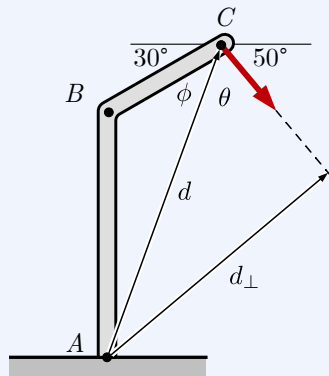

1. Use the law of sines and law of cosines to find distance d from A to C and the angle ϕ in triangle ABC .

$$d^2 = 5.5^2 + 3^2 - 2(3)(5.5) \cos 120^\circ$$

$$d = 7.47 \text{ m}$$

$$\frac{d}{\sin 120^\circ} = \frac{5.5 \text{ m}}{\sin \phi} \implies \phi = 39.6^\circ$$

2. Then, find the angle θ in the right triangle and solve for the perpendicular distance.

$$\theta = 180^\circ - 30^\circ - 50^\circ - \phi = 60.36^\circ$$

$$d_\perp = d \sin \theta = 6.49 \text{ m}$$

3. Finally, use (4.1.1) to find the magnitude of M_A created by 400 N force F .

$$M_A = F d_\perp = 2596 \text{ N}\cdot\text{m}$$

This force produces a clockwise rotation of the column, so the corresponding scalar moment is negative and the moment expressed as a vector is

$$\mathbf{M}_A = 2596 \text{ N}\cdot\text{m} \odot$$

4.1.2 Direction of a Moment

In two-dimensional problems, moment vectors are perpendicular to the page and moments simplify to clockwise or counterclockwise rotation about a *point*, called the **point of interest** or **moment center**. The point of interest can be visualized as the point where the axis of rotation pierces the page. Since these moment vectors point into the third dimension, they are usually drawn as circular arrows in the plane of the page.

Consider the two moments acting on a horizontal surface, shown below. To determine the *sense* of these moments, i.e. whether the vectors point up or down, apply the right-hand rule. Imagine grasping the axis of rotation with your right hand, with your fingers curling in the direction of rotation; your thumb then points in the direction of the moment vector. Using this technique, we observe that counterclockwise moments point upward, or out of the page, while the clockwise moments point downward or into the page. In other words, counterclockwise moment vectors point towards the positive z direction and clockwise moments point in the $-z$ direction.

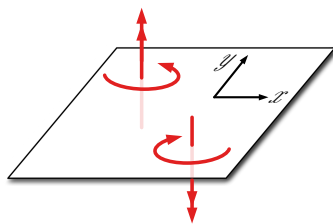

Figure 4.1.4 Moments in the plane of the page.

Pause your reading now to apply the right-hand rule yourself to determine the direction of the two moments in [Figure 4.1.4](#)

In three dimensions, moment vectors are more difficult to visualize, because they can point in any direction in 3-D space, however they still point along an axis of rotation with sense determined by the right hand rule.

As discussed in [Subsection 2.8.1](#), there are several alternative methods for applying the right-hand rule, however they all define a direction that is mutually perpendicular to two other vectors. To find the direction of a moment, the first of these vectors is a position vector which points *from* the point of interest *to* a point on the force's line of action, and is designated \mathbf{r} . The second vector is the force, \mathbf{F} .

With the three-finger method, you align your right-hand index finger with vector \mathbf{r} and your middle finger with the force \mathbf{F} ; your thumb will point in the direction of the moment vector. Alternatively, you can align your thumb with \mathbf{r} and your index finger with \mathbf{F} ; your middle finger will point in the direction of the moment vector.



Figure 4.1.5 Three-finger right-hand rule for moments.

With the point-and-curl method, place your right hand flat and point your fingertips in the direction of \mathbf{r} . Rotate your hand until the force \mathbf{F} is perpendicular to the back of your hand and can rotate your fingers. In this position, your thumb defines the direction of the moment vector and also the axis of rotation.

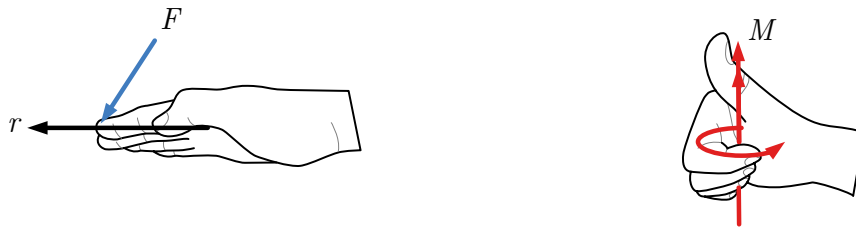

Figure 4.1.6 Point-and-curl right-hand rule for moments.

Any of these techniques may be used to find the direction of a moment. They all produce the same result so you don't need to learn them all, but make sure you have at least one method you can use accurately and consistently.

4.2 Scalar Addition of Moments

Since moments are vectors, they add according to the rules of vector addition. In three dimensions this usually involves finding the x , y , and z components of two or more moments and adding them to find the components of the resultant moment.

A simpler and more interactive approach using scalar components is available for moments in two dimensions.

4.2.1 Scalar Components

In [Subsection 3.3.2](#) we saw that vectors can be expressed as the product of a **scalar component** and a **unit vector**. For example, a 100 N force acting in the $-\mathbf{j}$ direction, i.e. straight down, can be represented by

$$\mathbf{F} = F_y \mathbf{j} = -100 \text{ N } \mathbf{j},$$

where $F_y = -100 \text{ N}$ is the scalar component and \mathbf{j} is the unit vector. The absolute value of F_y determines the magnitude of the force, and unit vector along with the sign of F_y determines its direction. The negative sign here indicates that the direction of \mathbf{F} is opposite to the direction of \mathbf{j} .

We have previously established two sign conventions for scalar components; we now add a third:

- For forces acting in the x direction, *right is positive*, corresponding to the direction of \mathbf{i} .
- For forces acting in the y direction, *up is positive*, corresponding to the direction of \mathbf{j} .
- For moments acting in the x - y plane, *counterclockwise moments are positive*, corresponding to the direction of \mathbf{k} according to the right-hand rule.

Example 4.2.1 Sign Conventions.

For each scalar component, determine whether the moment is clockwise or counterclockwise, and apply the right-hand rule to determine the direction of the corresponding moment vector.

A $M_1 = 30 \text{ N}\cdot\text{m}$

B $M_2 = -400 \text{ kN}\cdot\text{m}$

C $M_3 = 25 \text{ N}\cdot\text{m} \curvearrowright$

D $M_4 = -100 \text{ ft}\cdot\text{lb} \curvearrowright$

Solution. By the right-hand rule, counterclockwise moments in the x - y plane are vectors that point in the $+\mathbf{k}$ direction. The corresponding scalar component has a positive sign. Clockwise moments point in the $-\mathbf{k}$ direction and have a negative sign.

A M_1 is positive, so it is CCW and the vector points in the $+\mathbf{k}$ direction.

B M_2 is negative, so it is CW and the vector points $-\mathbf{k}$ direction.

C The arrow on M_3 establishes the positive direction as CW. A positive scalar component means that the direction is CW and the vector points in the $-\mathbf{k}$ direction.

D The arrow on M_4 establishes the positive direction as CW, but the negative sign on the scalar component means that the actual moment is CCW. The vector points in the $+\mathbf{k}$ direction.

In three dimensions, moments, like forces, can be resolved into components in the x , y , and z directions.

$$\mathbf{M} = M_x \mathbf{i} + M_y \mathbf{j} + M_z \mathbf{k}.$$

This means that the three scalar components are required to fully specify a moment in three dimensions, whereas only one is required for moments in a plane.

Warning 4.2.2

Be careful not to mix up magnitudes with scalar components.

- Both are scalar values with units.
- Magnitudes are never negative. Scalar components may be positive or negative.

- Scalar components always have an associated sign convention. It may be implied or specifically indicated. If the sign convention is unstated, assume that counterclockwise moments in the x - y plane are positive.
- There is no special symbol or notation to indicate whether a quantity represents a vector magnitude or a scalar moment, so pay attention to context.

4.2.2 Addition of Moments

Scalar components are most useful for adding and finding the resultant of several moments. When moments are expressed in terms of scalar components, vector addition reduces to algebraic addition of the scalar components.

To add several moments in a plane using scalar components, simply append a positive sign to the magnitude of counterclockwise moments and a negative sign to clockwise moments to create scalar components, then add the scalar components normally.

The resulting algebraic sum of the scalar components will be either positive, negative, or zero, and this sign indicates the direction of the resultant moment. If the result is positive, the resultant acts in the direction of the positive unit vector, and in the opposite direction if it is negative.

Example 4.2.3 Scalar addition.

Find the resultant of the following three moments:

$$\mathbf{M}_1 = 25 \text{ kN}\cdot\text{m} \curvearrowright, \mathbf{M}_2 = 40 \text{ kN}\cdot\text{m} \curvearrowleft, \text{ and } \mathbf{M}_3 = 30 \text{ kN}\cdot\text{m} \curvearrowright$$

Solution. Manually attaching the positive or negative signs according to the right-hand rule turns the magnitudes into scalar moments:

$$M_1 = -25 \text{ kN}\cdot\text{m}$$

$$M_2 = +40 \text{ kN}\cdot\text{m}$$

$$M_3 = -30 \text{ kN}\cdot\text{m}$$

Adding these moments algebraically gives the resultant scalar moment.

$$\begin{aligned} M &= M_1 + M_2 + M_3 \\ &= (-25 \text{ kN}\cdot\text{m}) + (40 \text{ kN}\cdot\text{m}) + (-30 \text{ kN}\cdot\text{m}) \\ &= -15 \text{ kN}\cdot\text{m} \end{aligned}$$

The negative sign indicates that the direction of the resultant moment is clockwise.

Interpreting the scalar moment as a vector gives:

$$\mathbf{M} = 15 \text{ kN}\cdot\text{m} \curvearrowright$$

The corresponding magnitude of \mathbf{M} is

$$|\mathbf{M}| = 15 \text{ kN}\cdot\text{m}$$

4.3 Varignon's Theorem

Varignon's Theorem is a method to calculate moments developed in 1687 by French mathematician Pierre Varignon (1654 – 1722). It states that

The sum of the moments of several concurrent forces about a point is equal to the moment of the resultant of those forces, or alternately, the moment of a force about a point equals the sum of the moments of its components.

This means you can find the moment of a force by first breaking it into components, evaluating the moments of the individual components, and finally summing them to find the net moment about the point.

This may sound like more work than just finding the moment of the original force, but in practice, it is often easier.

When applying Varignon's Theorem, you are free to select components in any direction, but the two most convenient choices are discussed below.

4.3.1 Parallel and Perpendicular Components

The first common way to apply Varignon's Theorem is to break the force creating the moment into two components, one parallel with the line segment connecting the moment center with the point of application of the force, and the other perpendicular to it.

Consider the wrench in the interactive diagram below. Assume that the length of the handle is d , the magnitude of the force is F , and the angle between the force and the handle is θ . The components parallel to the wrench handle and perpendicular to it are

$$F_{\parallel} = F \cos \theta \quad F_{\perp} = F \sin \theta.$$

By Varignon's theorem and the definition of the moment, (4.1.1), the sum of the moments of the components simplifies to:

$$M = F_{\perp} d, \tag{4.3.1}$$

because the contribution of the parallel component is zero since its line of action passes through the moment center A .

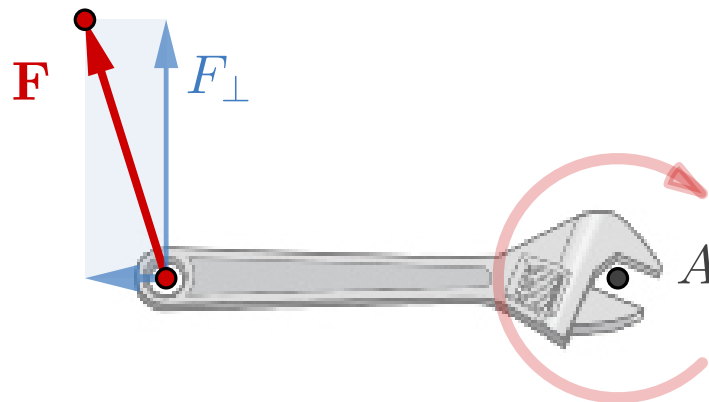

[Live Link](#)

Figure 4.3.1 Varignon's Theorem: Perpendicular Component

This result agrees with our intuitive understanding of how a wrench works; the greatest torque is developed when the force is applied at a right angle to the handle.

Equations (4.1.1) and (4.3.1) not only produce the same result, they are completely identical. If the length of the handle is d and the angle between the force \mathbf{F} and the handle is θ , then $d_{\perp} = d \sin \theta$, and $F_{\perp} = F \sin \theta$. Using either equation to calculate the moment gives

$$M = \left\{ \begin{array}{l} F d_{\perp} = F (d \sin \theta) \\ F_{\perp} d = (F \sin \theta) d \end{array} \right\} = Fd \sin \theta. \quad (4.3.2)$$

Example 4.3.2 Varignon's Theorem: Parallel and Perpendicular Components.

A gardener is moving soil with a wheelbarrow. The length of the handle from A to B is 45 in, and in the position shown, θ is 25° .

Find the moment created about axle A when she applies a vertical 30 lb force at B by resolving force F into components parallel and perpendicular to the handle.

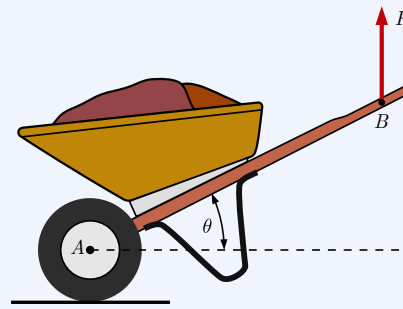

Solution.

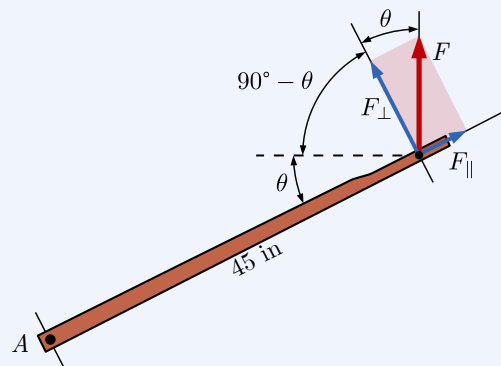

When the handle makes an angle of θ with the horizontal axis, the perpendicular component of F makes the same angle with the vertical, so resolving F into perpendicular and parallel components gives:

$$F_{\perp} = F \cos \theta = 27.19 \text{ lb} \qquad F_{\parallel} = F \sin \theta = 12.68 \text{ lb}$$

Summing the moments of the components we find

$$M_A = F_{\perp}(45 \text{ in}) + F_{\parallel}(0) = 1224 \text{ in}\cdot\text{lb}$$

Note that the parallel component does not contribute to the moment.

4.3.2 Horizontal and Vertical Components

Varignon's theorem is particularly convenient in situations where horizontal and vertical dimensions are provided, as is often the case. If you decompose the forces into horizontal and vertical components, you can find the moments of the components without difficulty. The resultant moment is the sum of the moments of the components.

Varignon's Equation is (4.3.3) and Figure 4.3.3 is the corresponding diagram

for the moment of force F about point A . Notice that the horizontal component is multiplied by the vertical distance, and the vertical component is multiplied by the horizontal distance since these are the perpendiculars, and that the signs on the terms can be either positive or negative, depending on the direction of the component moments.

$$M = \pm(F_x d_y) \pm (F_y d_x) \quad (4.3.3)$$

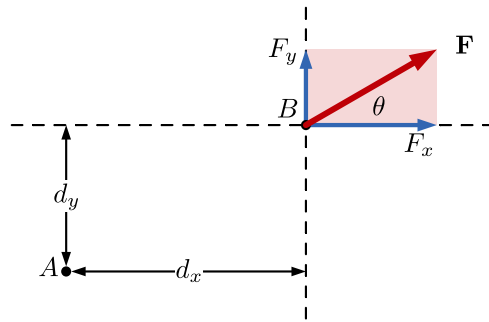
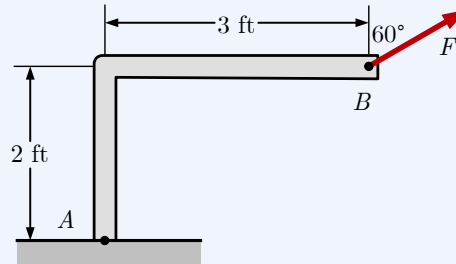

Figure 4.3.3 Varignon's Theorem Horizontal and Vertical Components

When applying Varignon's Theorem (4.3.3), take care to assign the correct sign to the individual moment terms; counterclockwise moments are positive, and clockwise negative are negative according to the right-hand rule, regardless of whether F_x acts left or right, or whether F_y acts up or down.

Example 4.3.4 Varignon's Theorem: Horizontal and Vertical Components.

A 750 lb force is applied to the frame as shown. Determine the moment this force makes about point A by resolving the force into horizontal and vertical components and applying Varignon's Theorem.



Solution. Force \mathbf{F} acts 60° from the vertical with a 750 lb magnitude, so its horizontal and vertical components are

$$F_x = F \sin 60^\circ = 649.5 \text{ lb}$$

$$F_y = F \cos 60^\circ = 375.0 \text{ lb}$$

For component F_x , the perpendicular distance from point A is 2 ft so the moment of this component is

$$M_1 = 2F_x = 1299 \text{ ft}\cdot\text{lb Clockwise.}$$

For component F_y , the perpendicular distance from point A is 3 ft so the moment of this component is

$$M_2 = 3F_y = 1125 \text{ ft}\cdot\text{lb counterclockwise.}$$

Assigning a negative sign to M_1 and a positive sign to M_2 to account for their directions and summing, gives the moment of \mathbf{F} about A .

$$\begin{aligned}M_A &= -M_1 + M_2 \\ &= -1299 + 1125 \\ &= -174 \text{ ft}\cdot\text{lb}\end{aligned}$$

The negative sign indicates that the resultant moment is clockwise, with a magnitude of 174 ft·lb.

$$\mathbf{M}_A = 174 \text{ ft}\cdot\text{lb} \text{ Clockwise.}$$

4.3.3 Moment Cross Products

The most robust and general method to find a moment of a force is to use the vector cross product

$$\mathbf{M} = \mathbf{r} \times \mathbf{F}, \quad (4.3.4)$$

where \mathbf{F} is the force creating the moment, and \mathbf{r} is a position vector from the moment center to any point on the line of action of the force, as shown in [Figure 4.3.5](#). The cross product is a vector multiplication operation, and the result is a vector perpendicular to the two vectors being multiplied.

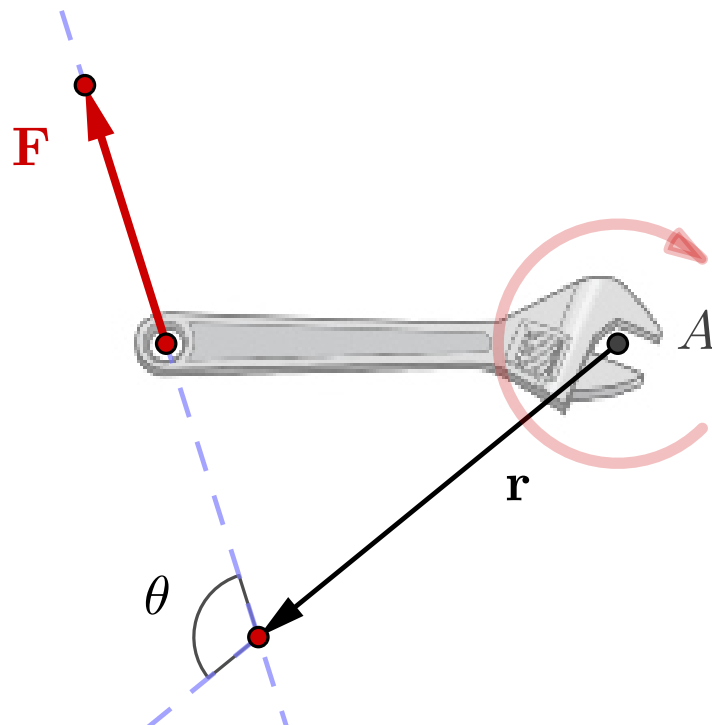

[Live Link](#)

Figure 4.3.5 Moment cross product. $\mathbf{M} = \mathbf{r} \times \mathbf{F}$

The cross product method is most often used to find moments in three dimensions, as will be discussed in [Section 4.4](#), but it can also be applied in two-dimensional problems.

The next example demonstrates the technique and compares it to the other methods we have already discussed. You will see that the cross product method is mathematically identical to applying Varignon's theorem.

Example 4.3.6 2D Moments - Four Ways.

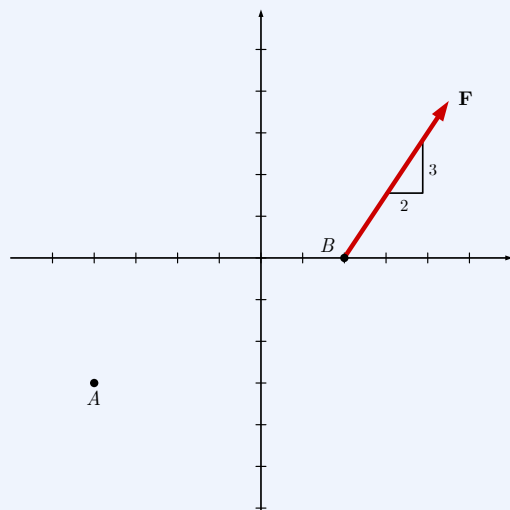

Force \mathbf{F} has a magnitude of 500 lbf and acts on point B in the direction shown.

Find the moment caused by force \mathbf{F} around point $A = (-4, -3)$ ft using different methods and verify that they give the same result.

This problem demonstrates four different ways you can solve the problem. The first two methods use vector algebra; the second two take a scalar approach that uses geometry and right-triangle trigonometry. All four methods are mathematically identical.

- (a) Find the moment of \mathbf{F} about point A using Varignon's Theorem,

$$\mathbf{M}_A = (\mathbf{r}_x \times \mathbf{F}_y) + (\mathbf{r}_y \times \mathbf{F}_x).$$

Answer. $\mathbf{M}_A = 1664.10 \text{ ft}\cdot\text{lbf} (+\mathbf{k})$

Solution. [Varignon's Theorem](#) states that the moment of a force is the sum of the moments of its components. In this example, we will determine the vertical and horizontal components of \mathbf{r} and \mathbf{F} , then add the cross products of the two perpendicular pairs.

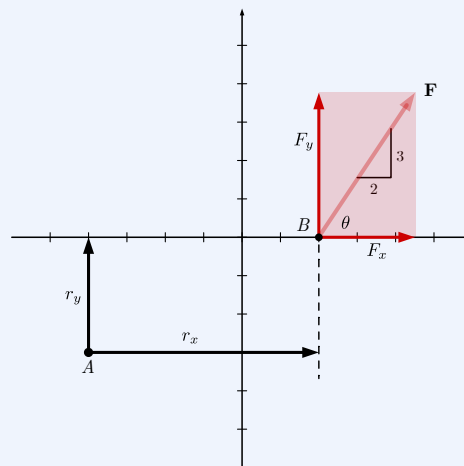

The 3:2 slope of \mathbf{F} can be expressed as an angle.

$$\theta = \tan^{-1} \frac{3}{2} = 56.3^\circ$$

Find the components of \mathbf{r} and \mathbf{F} .

$$\begin{aligned}\mathbf{F} &= 500 \text{ lbf} \langle \cos 56.3^\circ, \sin 56.3^\circ \rangle \\ &= \langle 277.35, 416.025 \rangle \text{ lbf} \\ \mathbf{r} &= \langle 6, 3 \rangle \text{ ft}\end{aligned}$$

Finally, following Varignon's Theorem, add the cross products of the perpendicular component pairs.

$$\begin{aligned}\mathbf{M}_A &= (\mathbf{r}_x \times \mathbf{F}_y) + (\mathbf{r}_y \times \mathbf{F}_x) \\ &= 6 \text{ ft} \cdot 416.025 \text{ lbf} (\mathbf{k}) + 3 \text{ ft} \cdot 277.35 \text{ lbf} (-\mathbf{k}) \\ &= 1664.1 \text{ ft} \cdot \text{lbf} (+\mathbf{k})\end{aligned}$$

Notes:

- When finding the moment of two-dimensional vectors in component form, this is often the preferred method, as it is quick and most find the process intuitive.
- The first cross product, $\mathbf{r}_x \times \mathbf{F}_y$, has a *positive value* because $\mathbf{i} \times \mathbf{j} = +\mathbf{k}$, *not* because you are simply multiplying two positive components.
- The second cross product, $\mathbf{r}_y \times \mathbf{F}_x$, results in a *negative value* because $\mathbf{j} \times \mathbf{i} = -\mathbf{k}$.
- All moments have units of force times distance, in this case [ft · lbf].
- The overall sign of \mathbf{M}_A determines the final direction. A positive value corresponds to a counterclockwise moment – right thumb out of the page – and a negative value indicates a clockwise moment. See [Figure 4.1.6](#) for the hand diagram.

(b) Find the moment of \mathbf{F} about point A using a vector cross product,

$$\mathbf{M}_A = \mathbf{r} \times \mathbf{F}.$$

Answer. $\mathbf{M}_A = 1664.10 \text{ ft} \cdot \text{lbf} (+\mathbf{k})$

Solution.

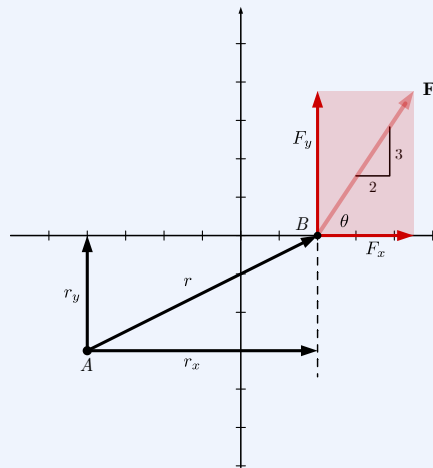

We can also solve for the moment \mathbf{M}_A using the vector determinant method of [Subsection 2.8.3](#). We can use the values of θ , \mathbf{r} , and \mathbf{F} computed in part (a) above. Jumping straight into the vector determinant, we find:

$$\mathbf{M}_A = \mathbf{r} \times \mathbf{F}$$

$$= \begin{vmatrix} \mathbf{i} & \mathbf{j} & \mathbf{k} \\ r_x & r_y & 0 \\ F_x & F_y & 0 \end{vmatrix}$$

$$= \begin{vmatrix} \mathbf{i} & \mathbf{j} & \mathbf{k} \\ 6 & 3 & 0 \\ 277.35 & 416.025 & 0 \end{vmatrix}$$

$$= 6 \text{ ft} (416.025 \text{ lbf}) (\mathbf{k}) + 3 \text{ ft} (277.35 \text{ lbf}) (-\mathbf{k})$$

$$= 1664.1 \text{ ft}\cdot\text{lbf} (+\mathbf{k})$$

Notes:

- Determinants are a robust way to compute two-dimensional cross products, but take a bit more effort than Varignon's Theorem. The math is *exactly the same* either way, which means that Varignon's Theorem is just a shortcut to working through a two-dimensional vector determinant.
- The signs on the cross-product terms $\mathbf{r}_x \times \mathbf{F}_y$ and $\mathbf{r}_y \times \mathbf{F}_x$ still come from the right-hand rule, and conveniently the process of multiplying diagonals in the determinant takes care of the signs.
- Recognize that the reason we multiply diagonals in a determinant is that we only want to multiply the *perpendicular* components.

(c) Find the moment of \mathbf{F} about point A by finding the perpendicular distance d_{\perp} ,

$$M_A = F d_{\perp}.$$

Answer. $\mathbf{M}_A = 1664.10 \text{ ft}\cdot\text{lbf} (+\mathbf{k})$

Solution.

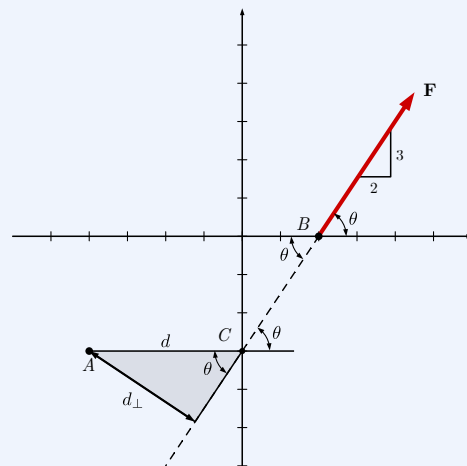

This solution requires you to find the perpendicular distance d_{\perp} between the point A and line-of-action of \mathbf{F} . One way to find this distance is shown below.

- Draw a moderately large and accurate diagram. Too much confusion has been created by small, inaccurately-drawn diagrams. Include a right triangle whose hypotenuse connects the moment center A with a convenient point on the line of action of \mathbf{F} . We have chosen point $C = (0, -3)$, although point B would work as well. Can you prove that C is on the line of action?
- Since the angle θ between the line of action of the force and any horizontal line is the same everywhere, θ appears three more times on this diagram, and gives us an angle in the right triangle.
- Use right triangle trigonometry to find d_{\perp} .

$$\begin{aligned}\sin \theta &= \frac{d_{\perp}}{AC} \\ d_{\perp} &= AC (\sin \theta) \\ &= 4 (\sin 56.3^{\circ}) \\ &= 3.328 \text{ ft}\end{aligned}$$

- Finally, compute the moment about A .

$$\begin{aligned}M_A &= F d_{\perp} \\ &= 3.328 \text{ ft} (500 \text{ lbf}) \\ &= 1664.10 \text{ ft}\cdot\text{lbf} \\ \mathbf{M}_A &= 1664.10 \text{ ft}\cdot\text{lbf} (+\mathbf{k})\end{aligned}$$

The $(+\mathbf{k})$ direction of \mathbf{M}_A comes from the observation of the right-hand rule, as scalar moment computations are not directional.

- (d) Find the moment of \mathbf{F} about point A by finding the perpendicular component of \mathbf{F} ,

$$M_A = F_{\perp} d.$$

Answer. $\mathbf{M}_A = 1664.10 \text{ ft}\cdot\text{lbf} (+\mathbf{k})$

Solution.

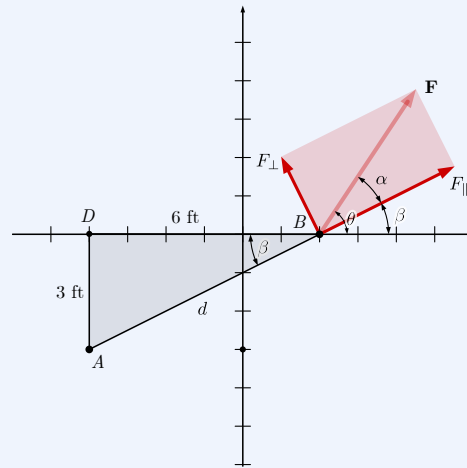

This solution requires you to find the rectangular component of force \mathbf{F} perpendicular to segment d connecting the moment center A with a point on the line of action of \mathbf{F} .

One approach to finding F_{\perp} is shown below.

- (a) Draw a large and accurate diagram to assist in finding the distances and angles in this problem.

Draw a line through point A and the point where \mathbf{F} acts, or to any other convenient point on its line of action. Then draw a rectangle aligned with this line, indicating the parallel and perpendicular components of \mathbf{F} . This rectangle consists of two congruent right triangles, having the force as their common hypotenuse. You will need to find an angle inside the triangle to find the components.

- (b) Use triangle ABD to compute angle β and the length of the hypotenuse d .

$$\beta = \tan^{-1} \left(\frac{3}{6} \right) = 26.565^\circ$$

$$d = \sqrt{6^2 + 3^2} = 6.708 \text{ ft}$$

- (c) Recalling that we have previously found $\theta = 56.31^\circ$, find α .

$$\alpha = \theta - \beta = 29.74^\circ$$

- (d) Find \mathbf{F}_{\perp} using the force triangle.

$$\begin{aligned} F_{\perp} &= F \sin \alpha \\ &= 500 \text{ lbf} \sin 29.74^\circ \\ &= 248.07 \text{ lbf} \end{aligned}$$

(e) Finally, compute the magnitude M_A and the vector \mathbf{M}_A .

$$\begin{aligned}M_A &= F_{\perp} d \\ &= 248.07 \text{ lbf} \cdot 6.708 \text{ ft} \\ \mathbf{M}_A &= 1664.10 \text{ ft} \cdot \text{lbf} (+\mathbf{k})\end{aligned}$$

The counterclockwise direction ($+\mathbf{k}$) comes from the right-hand rule, since scalar moment computations are not directional.

We have discussed several different approaches for finding the moment of a force about a point in the preceding sections. While all of these methods produce the same result, you will frequently find that one method is computationally simpler to apply than another. The simplest method generally depends on what is known and unknown in a given situation, so we recommend that you become familiar with all these methods.

The interactive diagram below will help you visualize the different approaches for finding moments that were covered.

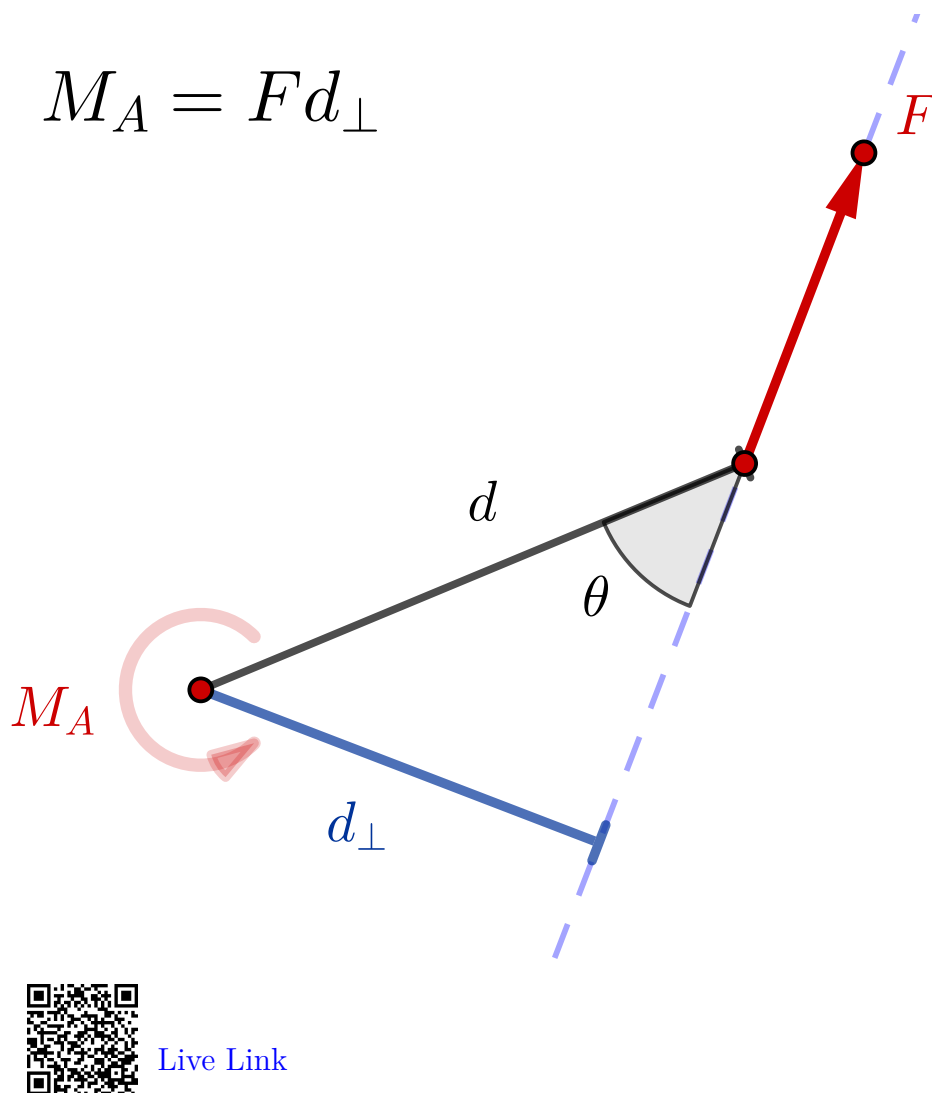

[Live Link](#)

Figure 4.3.7 Four equivalent approaches to finding a moment about a point.

4.4 3D Moments

Key Questions

- Where does the moment arm vector \mathbf{r} start and end?
- Why does Varignon's Theorem give you the same answer as a determinant?
- How can you combine a dot product and a cross product to find the moment about a line?
- Why does a mixed-triple determinant give you a scalar while a cross-

product determinant gives you a vector?

The circular arrows we used to represent vectors in two dimensions are unclear in three dimensions, so instead, moments are represented as arrows with x , y , and z components, like force and position vectors. You will sometimes see moments indicated with double arrowheads to differentiate them from force vectors.

In three dimensions, it is usually not convenient to use geometry to find the moment arm for equation (4.1.1), so instead we will use the vector cross product method, which is easier to apply but less intuitive.

4.4.1 3D Cross Products

The mathematics of cross products was discussed in Section 2.8, and equation (2.8.1) provides one method to calculate a moment cross products

$$\mathbf{M} = |\mathbf{r}||\mathbf{F}| \sin \theta \hat{\mathbf{u}} \quad (4.4.1)$$

. Here, θ is the angle between the two vectors as shown in Figure 4.3.5 above, and $\hat{\mathbf{u}}$ is the unit vector perpendicular to both \mathbf{r} and \mathbf{F} with the direction coming from the right-hand rule. This equation is useful if you know or can find the magnitudes of \mathbf{r} and \mathbf{F} and the angle θ between them. This equation is the vector equivalent of (4.3.2).

Alternatively, if you know or can find the components of the position \mathbf{r} and force \mathbf{F} vectors, it's typically easiest to evaluate the moment cross product using the determinant form discussed in Subsection 2.8.3.

$$\begin{aligned} \mathbf{M} &= \mathbf{r} \times \mathbf{F} \\ &= \begin{vmatrix} \mathbf{i} & \mathbf{j} & \mathbf{k} \\ r_x & r_y & r_z \\ F_x & F_y & F_z \end{vmatrix} \\ &= (r_y F_z - r_z F_y) \mathbf{i} - (r_x F_z - r_z F_x) \mathbf{j} + (r_x F_y - r_y F_x) \mathbf{k} \end{aligned} \quad (4.4.2)$$

Here, r_x , r_y , and r_z are components of the vector describing the distance from the point of interest to the force. F_x , F_y , and F_z are components of the force. The resulting moment has three components.

$$\begin{aligned} M_x &= (r_y F_z - r_z F_y) \\ M_y &= -(r_x F_z - r_z F_x) \\ M_z &= (r_x F_y - r_y F_x) \end{aligned}$$

These represent the component moments acting around each of the three coordinate axes. Note the negative sign in front of M_y , which ensures that the cross products maintain the correct signs. The magnitude of the resultant moment can be calculated using the three-dimensional Pythagorean Theorem.

$$M = |\mathbf{M}| = \sqrt{M_x^2 + M_y^2 + M_z^2} \quad (4.4.3)$$

It is important to avoid three common mistakes when setting up the cross product.

- The order must always be $\mathbf{r} \times \mathbf{F}$, never $\mathbf{F} \times \mathbf{r}$. The moment arm \mathbf{r} appears in the middle line of the determinant and the force \mathbf{F} on the bottom line.
- The moment arm \mathbf{r} must always be measured from the moment center to the line of action of the force. Never from the force to the point.
- The signs of the components of \mathbf{r} and \mathbf{F} must follow those of a right-hand coordinate system.

In two dimensions, r_z and F_z are zero, so (4.4.2) reduces to

$$\begin{aligned} \mathbf{M} &= \mathbf{r} \times \mathbf{F} \\ &= \begin{vmatrix} \mathbf{i} & \mathbf{j} & \mathbf{k} \\ r_x & r_y & 0 \\ F_x & F_y & 0 \end{vmatrix} \\ &= (r_x F_y - r_y F_x) \mathbf{k} \end{aligned} \quad (4.4.4)$$

. This is just the vector equivalent of [Varignon's Theorem](#) in two dimensions, with the correct signs automatically determined from the signs on the scalar components of \mathbf{F} and \mathbf{r} .

4.4.2 Moment about a Point

The next two interactives should help you visualize moments in three dimensions.

The first shows the force vector, position vector, and the resulting moment all placed at the origin for simplicity. The moment is perpendicular to the plane containing \mathbf{F} and \mathbf{r} and has a magnitude equal to the 'area' of the parallelogram with \mathbf{F} and \mathbf{r} for sides.

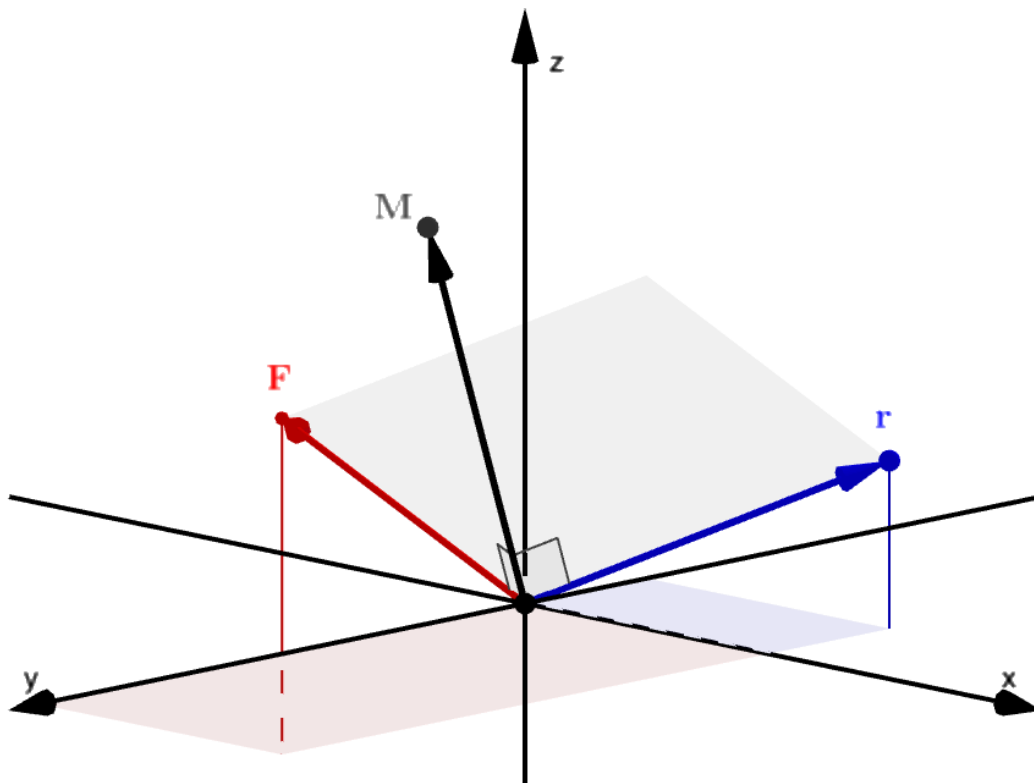

[Live Link](#)

Figure 4.4.1 Moment about the origin.

The second interactive shows a more realistic situation. The moment center is at an arbitrary point A , and the line of action of force \mathbf{F} passes through arbitrary points P_1 and P_2 . The position vector \mathbf{r} is the vector from A to a point on the line of action, and the force \mathbf{F} can be slid anywhere along that line.

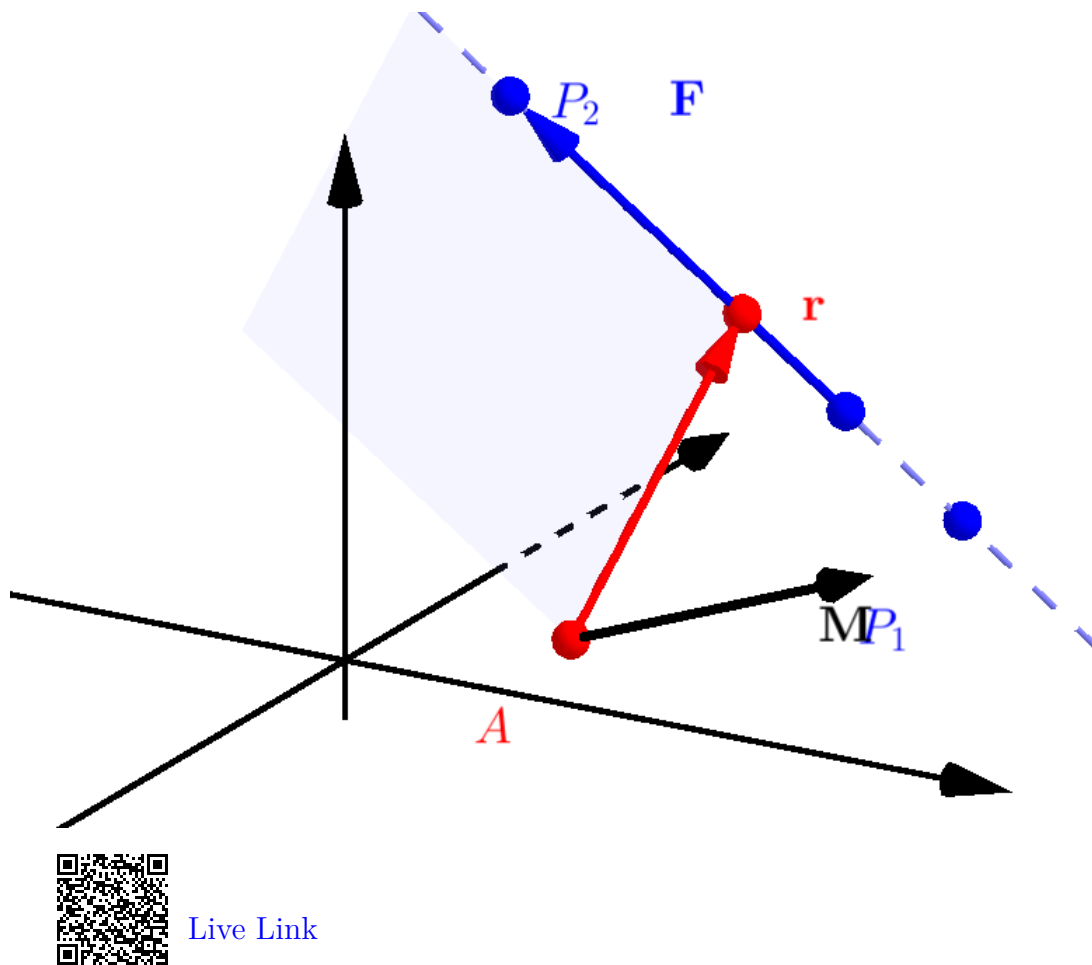
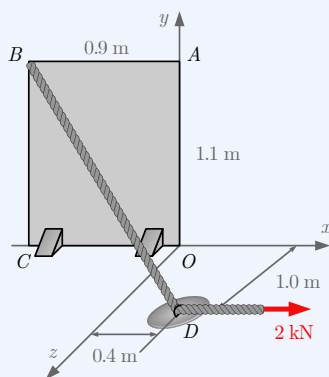

Figure 4.4.2 Moment about an arbitrary point.

Example 4.4.3 3D Moment about a Point.



A thin plate $OABC$ sits in the xy plane. Cable BD pulls with a tension of 2 kN through a frictionless ring at point D . Find the moment caused by the tension force around point O .

Solution. Start the problem by using the position information and tension magnitude to find the force vector \mathbf{F}_{BD} . This will be done in three steps:

1. *Find the position vector \mathbf{BD}* : Find position vectors by either subtracting the start-point coordinates from the end-point coordinates or focusing on the changes in the position components from B to D .

$$\begin{aligned}\mathbf{BD} &= D - B \\ &= (0.4, 0, 1.0) \text{ m} - (-0.9, 1.1, 0) \text{ m} \\ &= \langle 1.3, -1.1, 1 \rangle \text{ m}\end{aligned}$$

2. *Find the unit vector of \mathbf{BD}* : Compute a unit vector by dividing \mathbf{BD} by the total length of BD .

$$\begin{aligned}BD &= |\mathbf{BD}| = \sqrt{1.3^2 + (-1.1)^2 + 1.0^2} \\ &= 1.975 \text{ m} \\ \widehat{\mathbf{BD}} &= \frac{\mathbf{BD}}{BD} \\ &= \frac{\langle 1.3, -1.1, 1 \rangle \text{ m}}{1.975 \text{ m}} \\ &= \langle 0.658, -0.557, 0.506 \rangle\end{aligned}$$

Note that $\widehat{\mathbf{BD}}$ is unitless and is the pure direction of \mathbf{BD} .

3. *Multiply the unit vector by force magnitude*: Now multiply $\widehat{\mathbf{BD}}$ by the 2 kN force magnitude to find the force components.

$$\begin{aligned}\mathbf{F}_{BD} &= F_{BD}(\widehat{\mathbf{BD}}) \\ &= 2 \text{ kN} \langle 0.658, -0.557, 0.506 \rangle \\ &= \langle 1.317, -1.114, 1.013 \rangle \text{ kN}\end{aligned}$$

Next, find the moment arm from point O to the line of action of the force. There are two obvious options for moment arms, either \mathbf{r}_{OB} or \mathbf{r}_{OD} . To demonstrate how both moment arms give the same answer, solutions for both moment arms will be shown.

Option 1: Moment using \mathbf{r}_{OB}

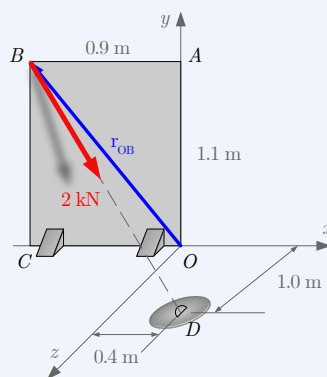

- Moment arm \mathbf{r}_{OB} starts at the point we are taking the moment around, O , and ends at the point B .

$$\begin{aligned}\mathbf{OB} &= B - O \\ &= (-0.9, 1.1, 0) \text{ m} - (0, 0, 0) \text{ m} \\ &= \langle -0.9, 1.1, 0 \rangle \text{ m}\end{aligned}$$

- Cross \mathbf{r}_{OB} with \mathbf{F}_{BD} to find the moment of \mathbf{F}_{BD} about point O .

$$\begin{aligned}\mathbf{M}_O &= \mathbf{r}_{OB} \times \mathbf{F}_{BD} \\ &= \begin{vmatrix} \mathbf{i} & \mathbf{j} & \mathbf{k} \\ -0.9 & 1.1 & 0 \\ 1.317 & -1.114 & 1.013 \end{vmatrix} \\ &= \langle 1.114, 0.911, -0.446 \rangle \text{ kN}\end{aligned}$$

Option 2: Moment using \mathbf{r}_{OD} :

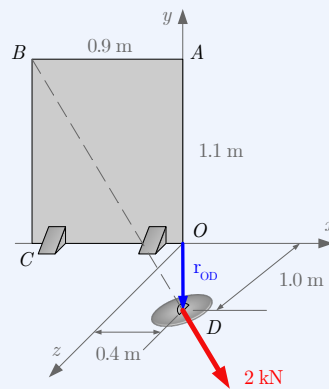

- Moment arm \mathbf{r}_{OD} starts at the point we are taking the moment around, O , and ends at the point D .

$$\begin{aligned}\mathbf{OD} &= D - O \\ &= (0.4, 0, 1.0) \text{ m} - (0, 0, 0) \text{ m} \\ &= \langle 0.4, 0, 1.0 \rangle \text{ m}\end{aligned}$$

- Cross \mathbf{r}_{OD} with \mathbf{F}_{BD} to find the moment of \mathbf{F}_{BD} about point O .

$$\begin{aligned}\mathbf{M}_O &= \mathbf{r}_{OD} \times \mathbf{F}_{BD} \\ &= \begin{vmatrix} \mathbf{i} & \mathbf{j} & \mathbf{k} \\ 0.4 & 0 & 1.0 \\ 1.317 & -1.114 & 1.013 \end{vmatrix} \\ &= \langle 1.114, 0.911, -0.446 \rangle \text{ kN}\end{aligned}$$

It is worth your effort to compute moments both ways for this example, or another problem, to prove to yourself that the answers work out exactly the same with different moment arms. You can actually select a moment arm from O to *any* point on line \mathbf{BD} and get the same result, but B and D are points on that line that we already know.

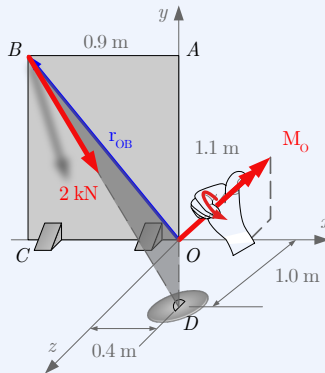

Drawing \mathbf{M}_O , demonstrates that a moment vector direction is both 1) the axis of rotation caused by \mathbf{T}_{BD} around point O , with the moment aligning to your thumb and the moment rotating around your fingers from the right-hand rule and 2) that \mathbf{M}_O is perpendicular to the plane formed by \mathbf{T}_{BD} and \mathbf{T}_{BD} . Recall that *all* cross products result in vectors perpendicular to the two crossed vectors.

4.4.3 Moment about a Line

In three dimensions, the moment of a force about a point can be resolved into components about the x , y and z axes. The moment produces a rotational tendency about all three axes simultaneously, but only a portion of the total moment acts about any particular axis.

We are often interested in finding the effect of a moment about a specific line or axis. For example, consider the moment created by a push on a door handle. Unless you push with a force exactly perpendicular to the hinge, only a portion of the total moment you produce will act around the hinge axis and be effective to open the door. The moment we are looking for is the vector projection of the moment onto the axis of interest. Vector projections were first discussed in [Subsection 2.7.4](#).

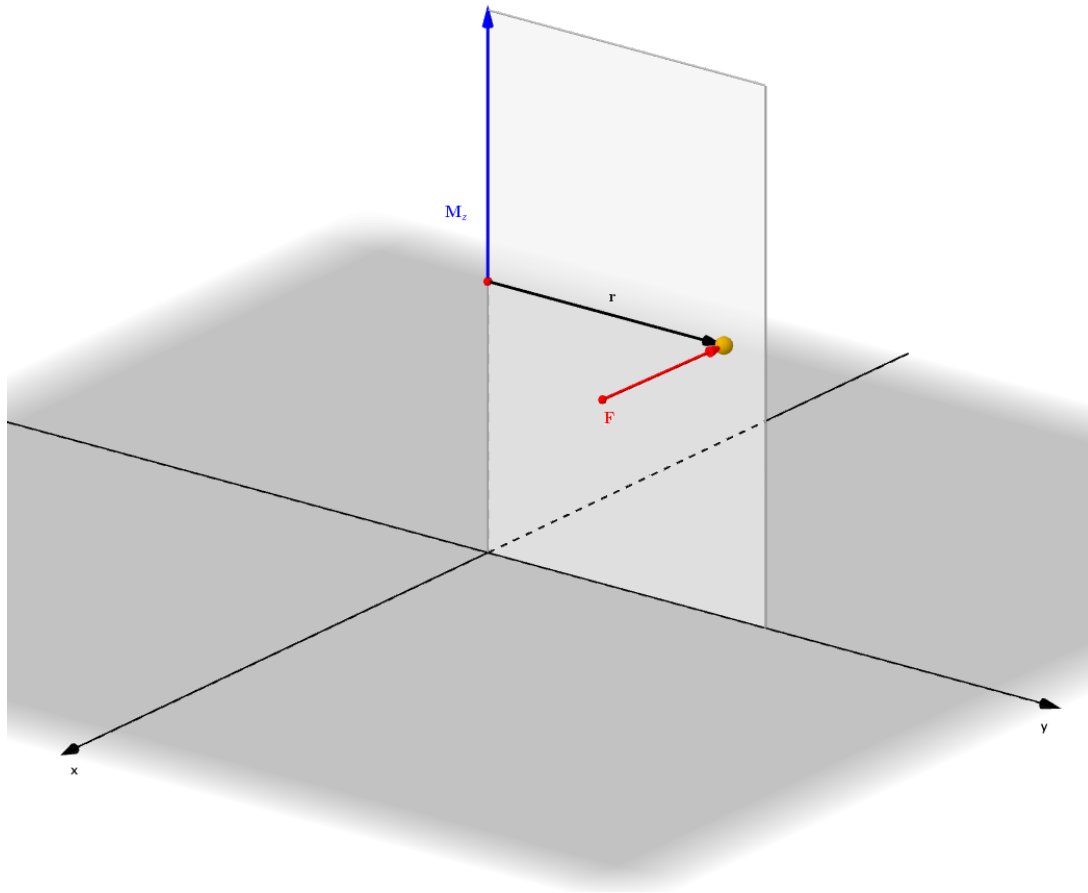

[Live Link](#)

Figure 4.4.4 Moment on a hinge.

The axis of interest does not need to be a coordinate axis. This interactive shows the projection of moment \mathbf{M} on a line passing through points A and B .

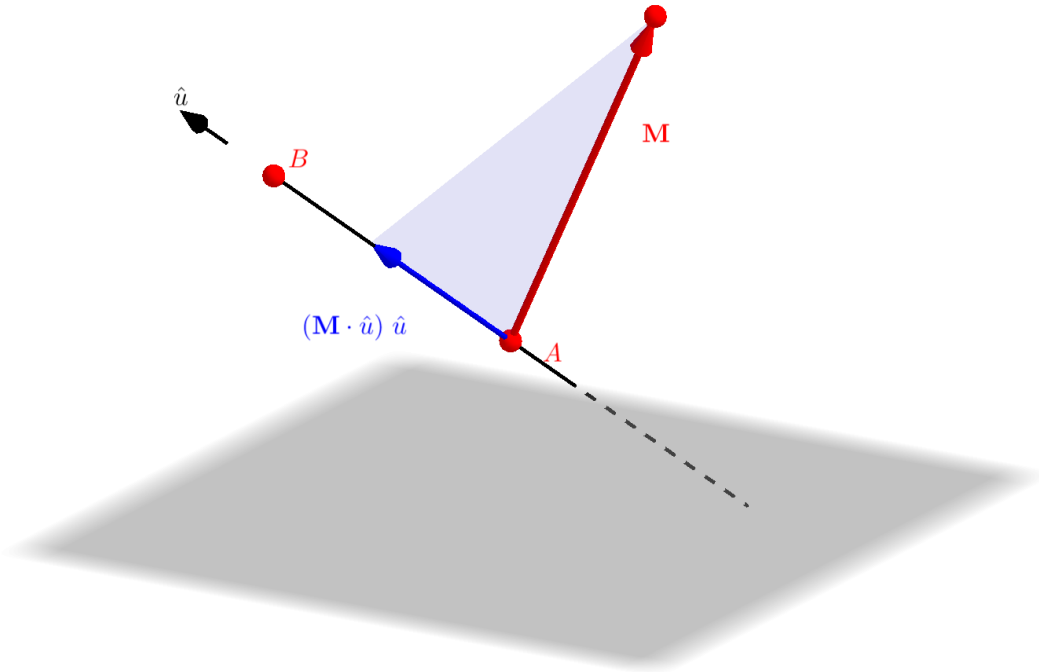

Live Link

Figure 4.4.5 Moment of a force about a line

To find the moment of a force about a line, three vectors are required:

- $\hat{\mathbf{u}}$, a unit vector pointing in the direction of the line or axis of interest.
- \mathbf{r} , a position vector from any point on the line of interest to any point on the line of action of the force.
- \mathbf{F} , the force vector. If you have multiple concurrent forces, you can treat them individually or add them together first and find the moment of the resultant.

Using these three vectors, we can compute the magnitude of the moment about a line in two related, but unique ways.

Two-Step Method: Separates the cross and dot products into two distinct steps.

- First, compute the moment of a the force about any point on the line of interest using the cross product, (4.3.4).

$$\mathbf{M} = (\mathbf{r} \times \mathbf{F})$$

- Next, find the scalar projection of the moment onto the line of interest using a dot product, (2.7.10).

$$M_{line} = \|\text{proj}_{\mathbf{u}} \mathbf{M}\| = \mathbf{M} \cdot \hat{\mathbf{u}}$$

Scalar Triple Product: Combines the cross and dot product into the determinant of a 3×3 matrix formed from the three vectors above.

- The scalar triple product consists of taking the determinant of a matrix consisting of the components of the line's unit vector $\hat{\mathbf{u}}$ in the top row, the components of a position vector \mathbf{r} in the middle row, and the components of the \mathbf{F} in the bottom row. The determinant can be computed in multiple ways, but we suggest using the augmented determinant method Figure 2.8.6 or computing it directly in a calculator which allows 3×3 matrix computations.
- Here are the computations:

$$\begin{aligned} M_{line} &= \|\text{proj}_{\mathbf{u}} \mathbf{M}\| = \hat{\mathbf{u}} \cdot (\mathbf{r} \times \mathbf{F}) \\ &= \begin{vmatrix} u_x & u_y & u_z \\ r_x & r_y & r_z \\ F_x & F_y & F_z \end{vmatrix} \\ &= (r_y F_z - r_z F_y) u_x + (r_z F_x - r_x F_z) u_y + (r_x F_y - r_y F_x) u_z \end{aligned}$$

- Note that the above determinant does *not* contain any unit vectors, like the \mathbf{i} , \mathbf{j} , and \mathbf{k} vectors that show up in the top of cross-product determinants. Therefore, you are just multiplying the *numbers* in the diagonals and adding them up to a scalar value.

A positive value indicates that the moment vector points in the $\hat{\mathbf{u}}$ direction, while a negative value indicates the moment points in the opposite direction.

Finally if you need to find the vector components of this moment about a line, multiplying the scalar projection by the line's unit vector will add direction to your scalar moment value, (2.7.11)

$$\mathbf{M}_{line} = \mathbf{M}_{\hat{\mathbf{u}}} = \|\text{proj}_{\mathbf{u}} \mathbf{M}\| \hat{\mathbf{u}}. \quad (4.4.5)$$

Example 4.4.6 3D Moment about a Line.

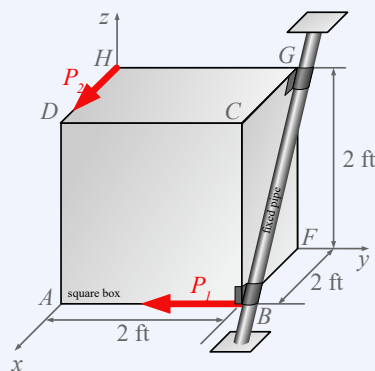

A 2 ft per side square box is attached to fixed pipe BG by two frictionless hinges B and G . There are two forces applied to the box, $\mathbf{P}_1 = 30$ lbf and $\mathbf{P}_2 = 25$ lbf.

For this two part example, first find the rotational moment from \mathbf{P}_1 about line BG and then find the moment of and \mathbf{P}_2 about line BG .

- (a) Find the magnitude of the moment caused by force \mathbf{P}_1 about line BG .

Answer. M_{P_1} about $BG = 0$ ft·lbf

Solution. The key observation to find the moment of \mathbf{P}_1 about line BG is that the line of action of \mathbf{P}_1 goes *directly* through line BG , thus force \mathbf{P}_1 produces no moment about line BG . Force \mathbf{P}_1 still pulls on the box and line BG , but causes no rotation *about* line BG . While you could set up a two-step or mixed triple to compute this moment, the simplest moment arm from line BG to force \mathbf{P}_1 would be $\mathbf{r} = \langle 0, 0, 0 \rangle$ ft which results in a M_{P_1} about $BG = 0$ ft·lbf.

- (b) Find the magnitude of the moment caused by force \mathbf{P}_2 about line BG .

Answer. M_{P_2} about $BG = 35.355$ ft·lbf

Solution. Keep in mind that to compute the magnitude of a moment about a line, we need to compute a vector moment about a point on the line and then dot this vector moment onto the line's unit vector. There are two options for this computation:

Option 1: The Two-Step Method separates the cross and dot products into two distinct steps.

- Compute the vector moment of \mathbf{P}_1 about any point on line BG , including \mathbf{M}_G or \mathbf{M}_B , then
- Dot \mathbf{M} onto the unit vector \widehat{BG}

Option 2: The Scalar Triple Product combines the cross and dot product into a single matrix determinant, including the following vectors:

- Top row: Unit vector for the line of interest \widehat{BG}

- Middle row: Moment arm from line of interest to force vector. We'll use \mathbf{r}_{HG} as it has the most zeros, which will simplify the algebra when computing the determinant.
- Bottom row: Components of force vector \mathbf{P}_2 .

Let's set up the vectors for the scalar triple product, starting with the unit vector \widehat{BG} .

The unit vector \widehat{BG} is found by dividing the position vector \mathbf{BG} by its own magnitude.

$$\widehat{BG} = \frac{\mathbf{BG}}{BG} = \frac{\langle -2.0, 0.0, 2.0 \rangle \text{ ft}}{\sqrt{(-2)^2 + 0^2 + 2^2} \text{ ft}} = \langle -0.707, 0.0, 0.707 \rangle$$

Next, the middle row of the scalar triple product is one of the moment arms from \mathbf{BG} to the force \mathbf{P}_2 . There are four options that will all result in the same answer after you compute the scalar triple product.

$$\begin{aligned}\mathbf{r}_{GH} &= \langle 0.0, -2.0, 0.0 \rangle \text{ ft} \\ \mathbf{r}_{GD} &= \langle 2.0, -2.0, 0.0 \rangle \text{ ft} \\ \mathbf{r}_{BH} &= \langle -2.0, -2.0, 2.0 \rangle \text{ ft} \\ \mathbf{r}_{BD} &= \langle 0.0, -2.0, 2.0 \rangle \text{ ft}\end{aligned}$$

We'll use \mathbf{r}_{GH} going forward as it is a one-dimensional vector and the zeros will simplify the determinant.

Finally, the bottom row of the scalar triple product are the force vector components.

$$\mathbf{P}_2 = \langle 25, 0, 0 \rangle \text{ lbf}$$

Now, combining the three vectors, here is the triple scalar product matrix:

$$M_{P_2} \text{ about } BG = \begin{vmatrix} -0.707 & 0 & 0.707 \\ 0.0 \text{ ft} & -2.0 \text{ ft} & 0.0 \text{ ft} \\ 25 \text{ lbf} & 0 \text{ lbf} & 0 \text{ lbf} \end{vmatrix} = 35.355 \text{ ft}\cdot\text{lbf}$$

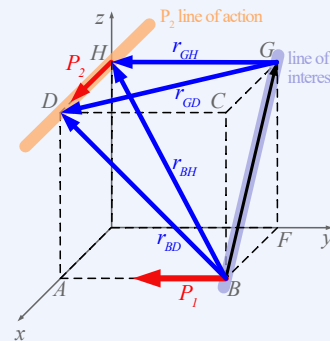

Hence, the magnitude of the moment caused by force \mathbf{P}_2 about line \mathbf{BG} is 35.355 ft·lbf. As we found a positive answer, this confirms that the rotation caused by \mathbf{P}_2 is in the same direction as the vector \mathbf{BG} , which is reinforced by the right-hand rule thumb direction in the diagram.

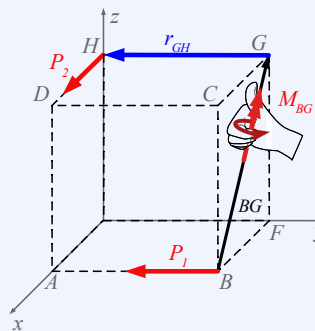

Validating the answer with the 2-step approach, we could first sum the moment of \mathbf{P}_2 about point G.

$$\mathbf{M}_G = (2 \text{ ft})(25 \text{ lbf}) \hat{k}$$

Given that the $\mathbf{M}_G \hat{k}$ moment and line \mathbf{BG} lie in a 2-D plane, you could even use a $\{45\}$ right triangle instead of a dot product to find the amount of \mathbf{M}_G which lies along line \mathbf{BG} .

$$M_{BG} = M_G(\cos 45^\circ)$$

$$M_{BG} = 50 \text{ ft}\cdot\text{lbf}(0.707)$$

$$M_{BG} = 35.355 \text{ ft}\cdot\text{lbf}$$

Not all problems have simple geometry where you can form a right triangle to perform a dot product, but this process demonstrates the two-step combination of a cross and a dot product to find a moment about a line.

4.5 Couples

Key Questions

- What makes a couple different than a typical $\mathbf{r} \times \mathbf{F}$ moment?
- Why is a couple considered a pure moment?
- If a couple is applied about the point we are summing moments, does it still need to be included in the sum of moments equation?

The moments we have considered so far were all caused by single forces producing rotation about a moment center. In this section, we will consider another type of moment, called a **couple**.

A couple consists of two parallel forces, equal in magnitude, opposite in

direction, and non-coincident. Couples are special because the pair of forces always cancel each other, which means that a couple produces a rotational effect but never translation. For this reason, couples are sometimes referred to as “pure moments.” The strength of the rotational effect is called the **moment of the couple** or the **couple-moment**.

When a single force causes a moment about a point, the magnitude depends on the magnitude of the force and the location of the point. In contrast, the moment of a couple is the same at every point and only depends on the magnitude of the opposite forces and the distance between them.

For example, consider the interactive where two equal and opposite forces with different lines of action form a couple. The moment of this couple is found by summing the moments of the two forces about an arbitrary moment center A , applying positive or negative signs for each term according to the right-hand rule. The moment of the couple is always

$$M = Fd_{\perp} \quad (4.5.1)$$

where d_{\perp} is the perpendicular distance between the lines of action of the forces.

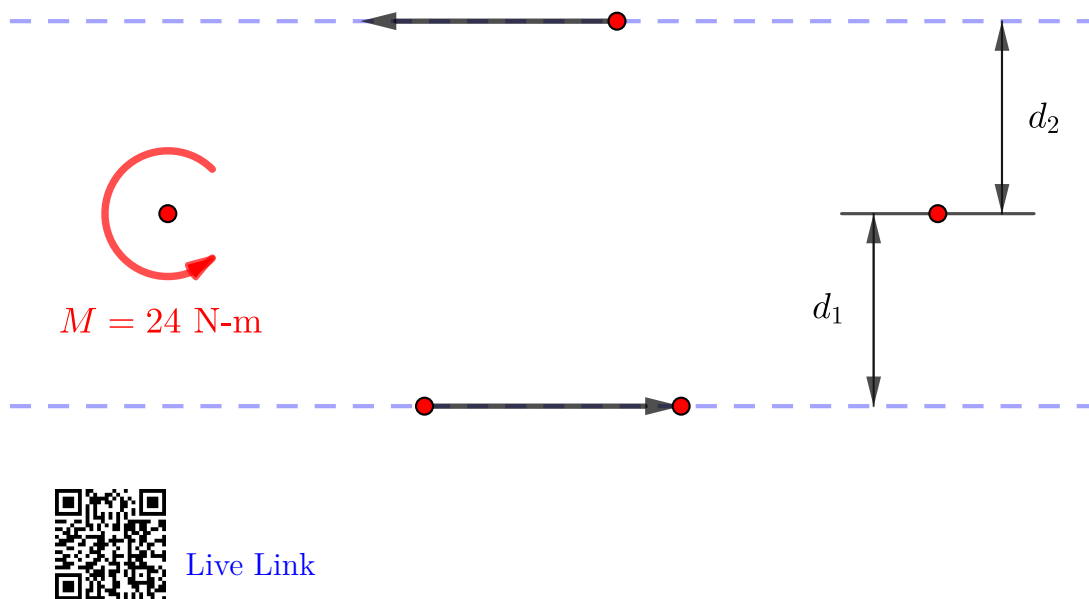

Figure 4.5.1 Moment of a couple.

In two dimensions, couples are represented by a curved arrow indicating the direction of the rotational effect. Following the right-hand rule, the value will be positive if the moment is counterclockwise and negative if it is clockwise. In three dimensions, a couple is represented by a normal vector arrow.

When adding moments to find the total or resultant moment, you must include couple-moments as well the $\mathbf{r} \times \mathbf{F}$ moments. In equation form, we could express this as:

$$\Sigma M_P = \Sigma(\mathbf{r} \times \mathbf{F}) + \Sigma(\mathbf{M}_{\text{couple}})$$

Thinking Deeper 4.5.2 Location Independence.

In this section, we have shown that couples produce the same moment at every point on the body. This means that the external effect of couples is *location independent*. Because the moment of a couple is location independent, the moment vector is not bound to any particular point and for this reason is a *free vector*.

We will learn in [Chapter 8](#) that moving a couple around on a rigid body does affect the *internal* loads or stresses inside a body, but changing the location of a couple does not change the *external* loading or reactions.

4.6 Equivalent Transformations

Key Questions

- What is an equivalent transformation?
- What are some examples of equivalent transformations?
- What are *external effects*?

An *equivalent transformation* occurs when a loading on an object is replaced with another loading that has the same *external* effect on the object. By external effect, we mean the response of the body that we can see from the outside, with no consideration of what happens to it internally. If the object is a free body, the external effect would be translation and rotation. In statics, since objects are not accelerating, the external effect really means the reactions at the supports required to maintain equilibrium. The external effects will be exactly the same before and after an equivalent transformation.

Equivalent transformation permits us to swap out one set of forces with another one without changing the fundamental physics of the situation. This is usually done to simplify or clarify the situation, or to give you an alternate way to think about, understand, and solve a mechanics problem.

You already know several equivalent transformations, although we have not used this terminology before. Here are some transformations you applied before.

Vector Addition. When you add forces together using the rules of vector addition, you are performing an equivalent transformation. You can swap out two or more components and replace them with a single equivalent resultant force.

Any number of *concurrent* forces can be added together to produce a single resultant force. By definition, the lines of action of concurrent forces all intersect at a common point. The resultant must be placed at this intersection point for the replacement to be equivalent. This is because before and after the

replacement, the moment about the intersection point is zero. If the resultant was placed somewhere else, that would not be true.

Replacing a Force with its Component. Resolving forces into components is also an equivalent transformation, as it is the inverse operation of vector addition. The components are usually orthogonal and in the coordinate directions, or in a given plane and perpendicular to it, but any combination of force components that add to the original force is equivalent.

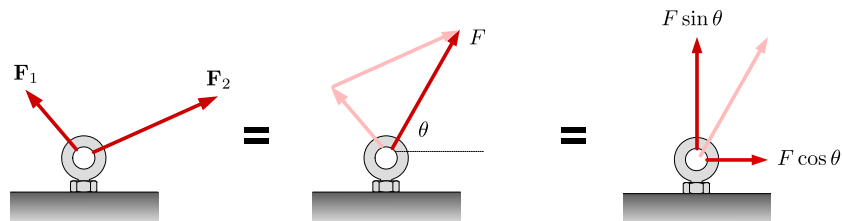

Figure 4.6.1 Equivalent transformations of vectors

In this diagram,

$$\mathbf{F} = \mathbf{F}_1 + \mathbf{F}_2 = (F; \theta) = \langle F \cos \theta, F \sin \theta \rangle.$$

The effects of the force in the x , y , and (in three dimensions the z) directions remain the same, and by Varignon's theorem, we know that the moment these forces make about any point will also be the same.

An interesting special case occurs when two forces are equal and opposite and have the same line of action. When these are added together, they cancel out, so replacing these two forces with nothing is an equivalent transformation. The opposite is true as well, so you can make two equal and opposite forces spontaneously appear at a point if you wish.

Thinking Deeper 4.6.2 Internal Effects.

We made a point of saying that equivalent systems of force have the same *external* effect on the body. This implies that there may be some other effects that are not the same. As you will see in [Chapter 8](#), we sometimes need to consider internal forces and moments. These are the forces inside a body that hold all the parts of the object to each other, otherwise, it would break apart and fail. Although the external effects are the same for all equivalent systems, the internal forces depend on the specifics of how the loads are applied.

Let's imagine that you have gone off-roading and have managed to get your Jeep stuck in the mud. You have two basic options to get it out: you can *pull* it out using the winch on the front bumper, or you can ask your friend to *push* you out with his truck. Both methods (assuming that they apply forces with the same magnitude, direction, and line of action) are statically equivalent, and both will equally move your vehicle forward.

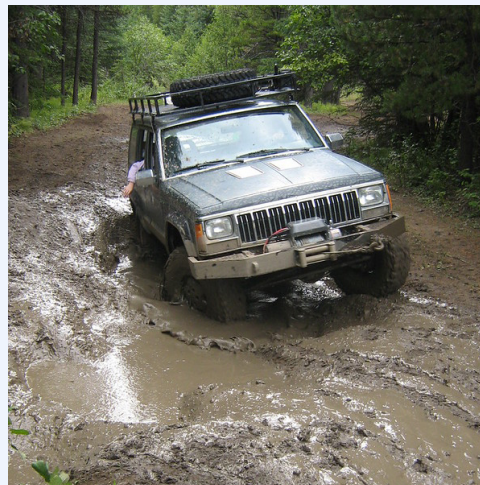

The difference is what might happen to your vehicle. With one method, there's a danger that you will rip your front bumper off, with the other you might damage your rear bumper. These are the internal effects, and they depend on *where* the equivalent force is applied. These forces are necessary to maintain rigidity and hold the parts of the body together.

Sliding a force along its line of action. Sliding a force along its line of action is an equivalent transformation because sliding a force does not change its magnitude, direction or the perpendicular distance from the line of action to any point, so the moments it creates do not change either. This transformation is called the “Principle of Transmissibility”.

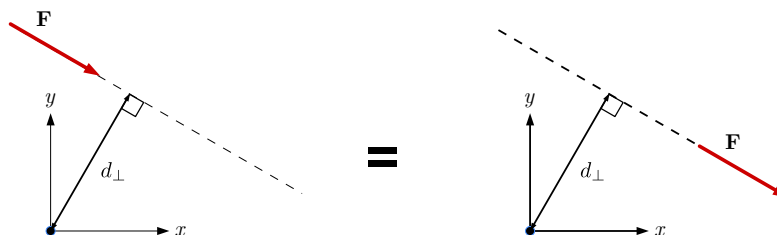

Figure 4.6.3 Sliding a vector along its line of action

Replacing a couple with couple-moment or vice-versa. A *couple*, defined as “two equal and opposite forces with different lines of action,” produces a pure turning action that is equivalent to a concentrated moment, called the *couple-moment*. Couples and couple-moments have no translational effect. Couple-moments are free vectors, which means that they are not bound to any point. Their external effect is on the entire body and is the same regardless of where it is applied.

This means that you are free to swap out a couple for its couple-moment, or swap a couple-moment for a couple that has the same moment, and you may put the replacement anywhere on you please and it will still be equivalent.

The diagram shows a series of equivalent transformations of a couple.

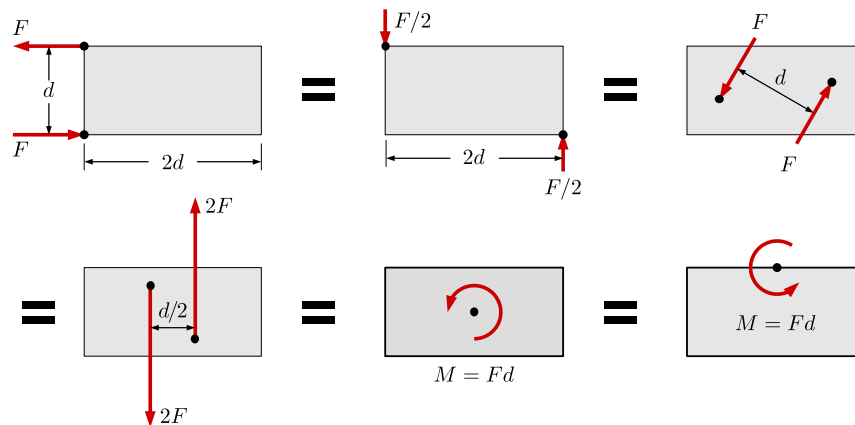

Figure 4.6.4 Equivalent transformations of couples

Concentrated moments are *free vectors*, which you may draw the circular arrow anywhere you like on the body. In other words, moving a concentrated moment from one point to another is an equivalent transformation. Remember, this equivalence only applies to the external effects. What happens inside the body definitely does depend on the specific point where the moment is applied.

Adding moments to produce a resultant moment. If more than one couple-moment or concentrated moment acts on an object, the situation may be simplified by adding them together to produce one *resultant moment*, \mathbf{M}_R . The standard rules of vector addition apply.

In two-dimensional problems, moments are either clockwise or counterclockwise, so they may be considered scalar values and added algebraically. Give counterclockwise moments a positive sign and clockwise moments a negative sign according to the right-hand rule sign convention. If this is done, the sign of the resultant moment will indicate the direction of the net moment. You can use the right-hand rule to establish the direction of the moment vector, which will point into or out of the page.

$$M_R = \Sigma M$$

Example 4.6.5 Equivalent Moment.

Two concentrated moments and a couple act on the object shown. Given: $M_1 = 400 \text{ N}\cdot\text{m}$, $M_2 = 200 \text{ N}\cdot\text{m}$, $F = 40 \text{ N}$, and $d = 2 \text{ m}$.

Replace these with a single, equivalent concentrated moment, and give the magnitude and direction of your result.

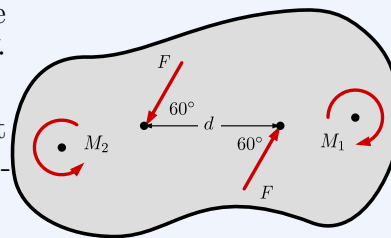

Solution. First, replace the couple with an equivalent couple, M_3 , the

magnitude of which is

$$\begin{aligned}M_3 &= Fd_{\perp} \\ &= Fd \sin 60^{\circ} \\ &= 69.3 \text{ N}\cdot\text{m}\end{aligned}$$

By observation, this is a counterclockwise moment, as is M_2 . M_1 is clockwise. Summing the scalar magnitudes gives the resultant moment. The signs of the terms are assigned according to the sign convention: positive if counterclockwise, negative if clockwise.

$$\begin{aligned}M_R &= \Sigma M \\ &= M_1 + M_2 + M_3 \\ &= -400 \text{ N}\cdot\text{m} + 200 \text{ N}\cdot\text{m} + 69.3 \text{ N}\cdot\text{m} \\ &= -130.7 \text{ N}\cdot\text{m} \\ \mathbf{M}_R &= 130.7 \text{ N}\cdot\text{m} \text{ clockwise}\end{aligned}$$

Resolving a moment into components. For three-dimensional moment vectors, another potential equivalent transformation is to resolve a moment vector into components. These may be orthogonal components in the x , y , and z directions, or components in a plane and perpendicular to it, or components in some other rotated coordinate system.

4.7 Statically Equivalent Systems

Key Questions

- What is an equivalent system?
- What is a resultant force?
- What is a resultant moment?
- Do you have to include both $\mathbf{r} \times \mathbf{F}$ moments and couples to find the resultant moment?
- How can you find the simplest equivalent system?
- When will the simplest equivalent system be a wrench?
- How can you determine if two loading systems are statically equivalent?

A loading system is a combination of load forces and moments that act on an object. It can be as simple as a single force, or as complex as a three-dimensional combination of many force and moment vectors.

You will see that any loading systems may be replaced with a simpler *statically equivalent system* consisting of one *resultant force* at a specific point and one *resultant moment* by performing a series of equivalent transformations. Force system resultants provide a convenient representation for complex force interactions at engineering connections that we will rely on later in a variety of contexts. For now, we will focus on the details of reducing a system to a single force and couple.

Depending on the original loading system, the resultant force, the resultant moment, or both may be zero. If they are both zero, it indicates that the object is in equilibrium under this load condition. If they are non-zero, the supports will need to provide an equal and opposite reaction to put the object into equilibrium.

The resultant force acting on a system, \mathbf{R} , can be found from adding the individual forces, \mathbf{F}_i , such that

$$\mathbf{R} = \sum \mathbf{F} = \mathbf{F}_1 + \mathbf{F}_2 + \mathbf{F}_3 + \dots$$

The resultant moment, \mathbf{M}_O , about a point O , can be found from adding all of the moments \mathbf{M} , about that point, including both $\mathbf{r} \times \mathbf{F}$ moments and concentrated moments.

$$\mathbf{M}_O = \sum \mathbf{M}_i = \mathbf{M}_1 + \mathbf{M}_2 + \mathbf{M}_3 + \dots$$

It is often more convenient to work with the scalar components of the resultant vectors since they separate the effects in the three coordinate directions.

$$\begin{aligned} R_x &= \sum F_x \\ R_y &= \sum F_y \end{aligned}$$

$$\begin{aligned} M_{Ox} &= \sum M_x \\ M_{Oy} &= \sum M_y \end{aligned}$$

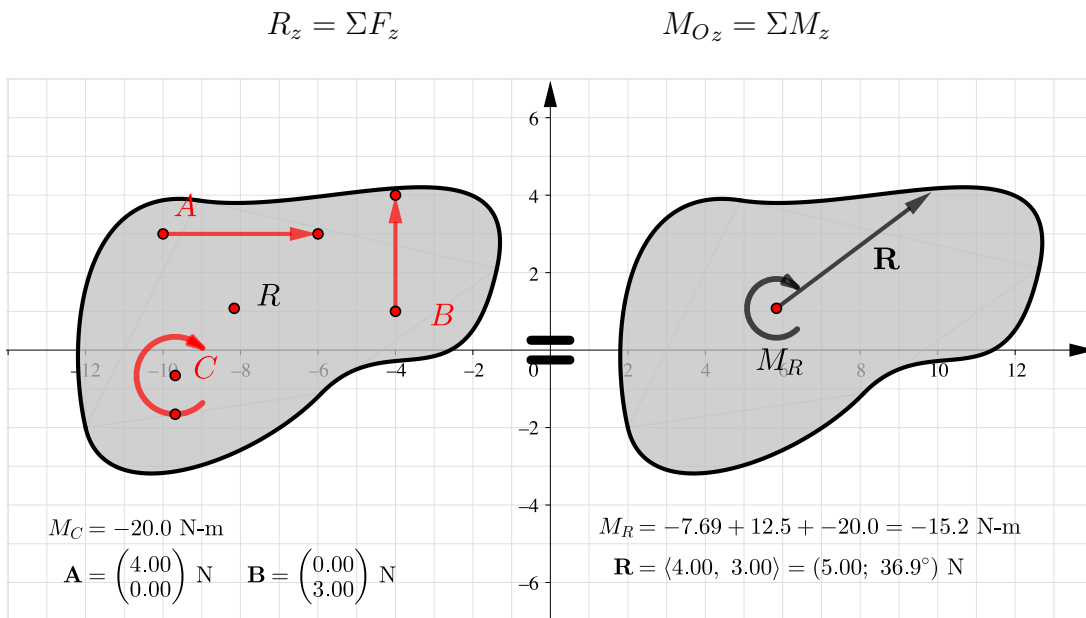

[Live Link](#)

Figure 4.7.1 Statically equivalent systems

Force-Couple Systems. One transformation you might want to make is to move a force to another location. While *sliding* a force along its line of action is fine, *moving* a force to another point changes its line of action and thus its rotational effect on the object, so moving a force to a new line of action is *not* an equivalent transformation.

Consider the cantilever beam below. In diagram (a), the load P is at the end of the beam, and in (b) it has been moved to the center. The external effects are shown in (c) and (d). Although the vertical reaction force is the P in both cases, the reaction moment at point O is $2P\ell$ in the first case and $P\ell$ in the second.

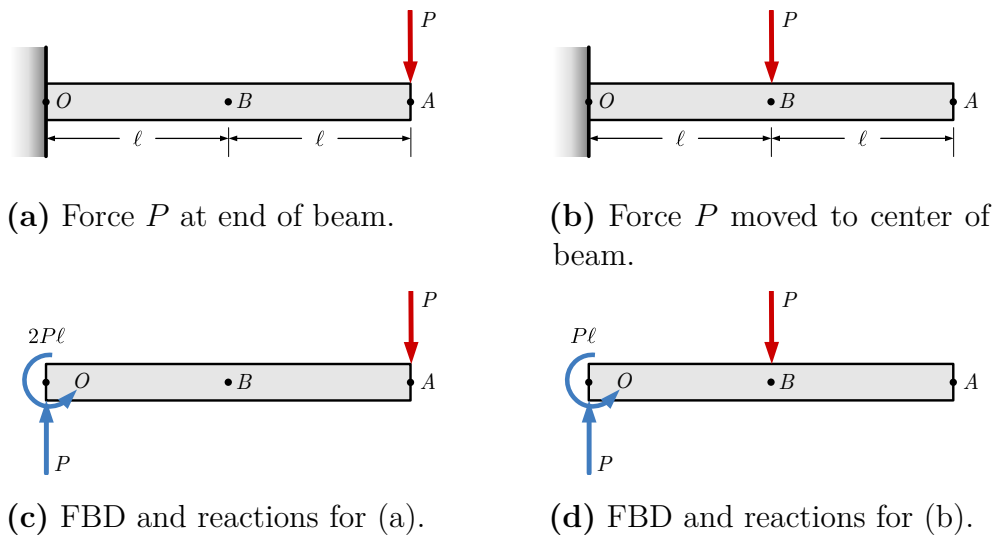

Figure 4.7.2 Moving a force is not an equivalent transformation

You *can* move a force to a new line of action in an equivalent fashion if you add a “compensatory couple” to undo the effect of changing the line of action. This can be accomplished with a series of individual equivalent transformations as shown in the diagram below. To move P to another location, first add two equal and opposite forces where you want the force to be, as in (b). Then recognize the couple you have formed (c), and replace it with an equivalent couple-moment. The result of this process is the *equivalent force-couple system* shown in diagram (d), which is statically equivalent to the original situation in (a).

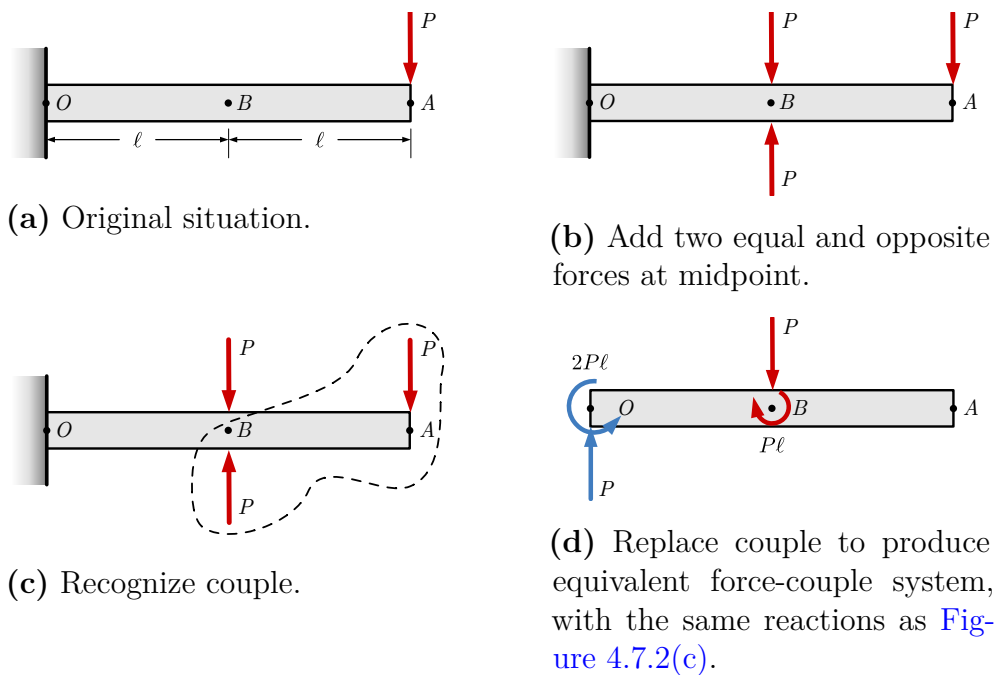

Figure 4.7.3 Equivalent Force-couple system

Evaluating the moment at point O was an arbitrary choice. Any other point would give the same result. For example, in the original situation (a) force P makes a clockwise moment $M = P\ell$ about the midpoint. When the force is moved to the center P creates no moment there, so a clockwise compensatory couple with a magnitude of $P\ell$ must be added to maintain equivalence. This is the same result as we found previously (d). The compensatory couple has been drawn centered around the midpoint, but this too is arbitrary because concentrated moments are free vectors and can be placed at any location.

Reduction of a complex system. Any loading system can be reduced to a statically equivalent system consisting of single force and a single moment at a specified point with the following procedure:

1. Determine the resultant moment about the specified point by considering all forces and concentrated moments on the original system.
2. Determine the resultant force by adding all forces acting on the original system.
3. Determine the resultant moment about a point in the original system
4. Create the statically equivalent system by replacing all loads with the resultant force and the resultant moment at the selected point.

Example 4.7.4 Eccentric loading.

An vertical column is supporting an eccentric load as shown.

Replace this load with an equivalent force-couple system acting at the center of the beam's top surface.

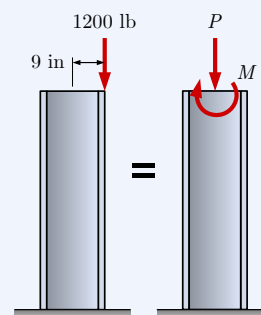

Solution. In order to move the vertical force 9 in to the left, a clockwise couple M must be added to maintain equivalence, where

$$\begin{aligned}
 M &= Pd \\
 &= (1200 \text{ lb})(9 \text{ in}) \\
 &= 10800 \text{ in}\cdot\text{lb} \\
 &= 900 \text{ ft}\cdot\text{lb}
 \end{aligned}$$

Example 4.7.5 Equivalent Force-couple System.

- Replace the system of forces in diagram (a) with an equivalent force-couple system at point A .
- Replace this force-couple system with a single equivalent force and specify its location.

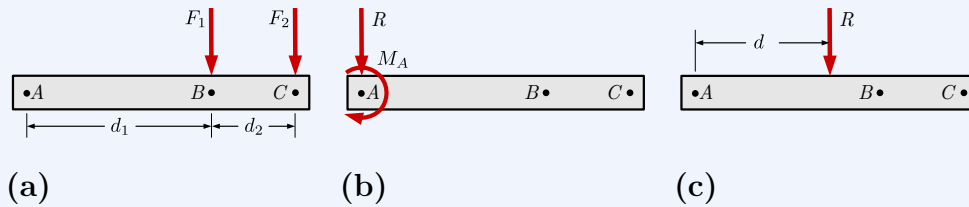

Figure 4.7.6

Solution. The original system is shown in (a). Since the F_1 and F_2 are parallel, the magnitude of the resultant force is just the sum of the two magnitudes and it points down.

$$R = F_1 + F_2$$

The resultant moment about point A is

$$M_A = F_1 d_1 + F_2 (d_1 + d_2).$$

To create the equivalent system (b), the resultant force and resultant moment are placed at point A .

The system in (b) can be further simplified to eliminate the moment at M_A , by performing the process in reverse.

In (c) we place the resultant force R a distance d away from point A such that the resultant moment around point A remains the same. This distance can be found using $M = Fd$.

$$d = M_A / R$$

The systems in (a), (b), and (c) are all statically equivalent

In this example, we started with two forces. We have found two different statically equivalent systems; one with a force and a couple, the other with a single force. This latter system is simpler than the original system.

It is important to note that static equivalence applies to external effects only. When determining internal forces, such as the shear and bending moment discussed in [Section 8.4](#) or when considering non-rigid bodies, the original loading system must be used.

Determining Equivalence. Two complex loading systems are equivalent if they reduce to the same resultant force and the same resultant moment about any arbitrary point.

Two loading systems are statically equivalent if

- The resultant forces are the equal
- The resultant moments about some point are equal

This process is illustrated in the following example.

Example 4.7.7 Finding Statically Equivalent Loads.

Which of the three loading systems shown are statically equivalent?

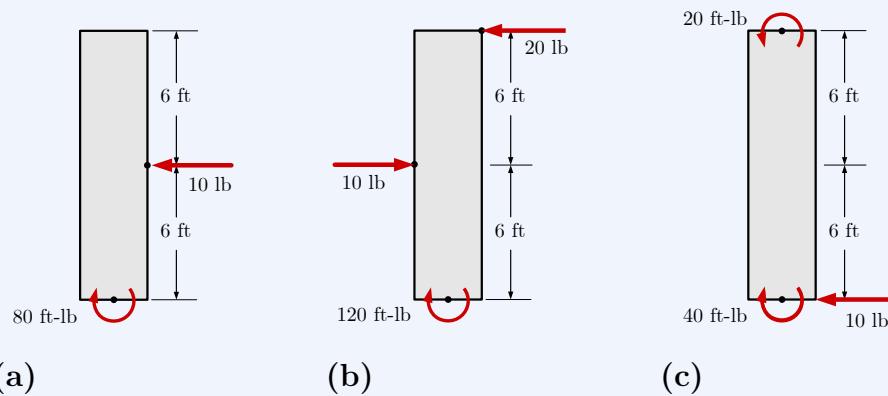

Figure 4.7.8

Solution.

1. *Strategy.*

Evaluate the resultant force and resultant moment for each case and compare. We choose to evaluate the resultant moment about point A, though any other point would work.

2. *For system (a).*

$$\begin{aligned}\mathbf{R} &= \langle -10, 0 \rangle \text{ lb} \\ \mathbf{M}_A &= -80 + 6(10) \\ &= -20 \text{ ft}\cdot\text{lb}\end{aligned}$$

3. *For system (b).*

$$\begin{aligned}\mathbf{R} &= \langle -20 + 10, 0 \rangle \text{ lb} \\ &= \langle -10, 0 \rangle \text{ lb}\end{aligned}$$

$$\begin{aligned}\mathbf{M}_A &= -120 + 12(20) - 6(10) \\ &= 60 \text{ ft}\cdot\text{lb}\end{aligned}$$

4. For system (c).

$$\begin{aligned}\mathbf{R} &= \langle -10, 0 \rangle \text{ lb} \\ \mathbf{M}_A &= -40 + 20 + 0(10) \\ &= -20 \text{ ft}\cdot\text{lb}\end{aligned}$$

Systems (a) and (c) are statically equivalent since \mathbf{R} and \mathbf{M}_A are the same in both cases. System (b) is not as its resultant moment is different than the other two.

Any load system can be simplified to its resultant force \mathbf{R} , and resultant couple \mathbf{M} , acting at any arbitrary point O . There are four common special cases, which are worth highlighting individually.

Concurrent forces. When all forces in a system are concurrent, the resultant moment about their common intersection point will always be zero. We then need only find the resultant force and place it at the point of intersection. The resultant moment about any other point is the moment of the resultant force \mathbf{R} about that point.

Parallel forces. When all forces in a system are parallel, the resultant force will act in this direction with a magnitude equal to the sum of the individual magnitudes. There will be no moment created about this axis, but we need to find the resultant moment about the other two rectangular axes. That is, if all forces act in the x direction, we need only find the resultant force in the x direction and the resultant moment about the y and z axes.

Coplanar forces. When all forces in a system are coplanar we need only find the resultant force in this plane and the resultant moment about the axis perpendicular to this plane. That is, if all forces exist in the x - y plane, we need only to sum components in the x and y directions to find resultant force \mathbf{R} , and use these to determine the resultant moment about the z axis. All two-dimensional problems fall into this category.

Wrench resultant. A wrench resultant is a special case where the resultant moment acts around the axis of the resultant force. The directions of the resultant force vector and the resultant moment vector are the same.

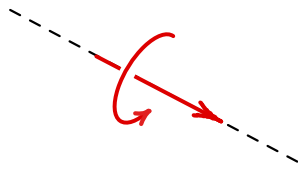

Figure 4.7.9 Wrench Resultant

For example, if the resultant force is only in the x direction and the resultant moment acts only around the x axis, this is an example of a wrench resultant. An everyday example is a screwdriver, where both the resultant force and axis of rotation are in-line with the screwdriver. A wrench resultant is considered positive if the couple vector and force vector point in the same direction, and negative if they point in opposite directions.

Any three-dimensional force-couple system may be reduced to an equivalent wrench resultant even if the resultant force and resultant moment do not initially form a wrench resultant.

To find the equivalent wrench resultant:

1. First, find the resultant force \mathbf{R} and resultant moment \mathbf{M} at an arbitrary point, O . These need not act along the same axis.
2. Resolve the resultant moment into scalar components M_{\parallel} and M_{\perp} , parallel and perpendicular to the axis of the resultant force.
3. Eliminate M_{\perp} by moving the resultant force away from point O by distance $d = M_{\perp}/R$

The simplified system consists of moment \mathbf{M}_{\parallel} and force \mathbf{R} and acting distance d away from point O . Since \mathbf{R} and \mathbf{M}_{\parallel} act along the same axis, the system has been reduced to a wrench resultant. Wrench resultants are the most general way to represent a complex force-couple system, but their utility is limited.

4.8 Exercises (Ch. 4)

Chapter 4 Exercises

Moments	0/165
Definition of a Moment	0/30 Not attempted
Varignon's Theorem	0/50 Not attempted
Moment of a Force about a Point	0/20 Not attempted
Semicircle	0/15 Not attempted
Opposing Moments using Varignon's Theorem	0/20 Not attempted
Moment Balance: L shape	0/10 Not attempted
Moment Balance: Z-shape	0/20 Not attempted
Couples	0/40
Moment of a Couple	0/15 Not attempted
Resultant Couple	0/15 Not attempted
Couples in Equilibrium	0/10 Not attempted
Equivalent Systems	0/115
Two Parallel Forces	0/20 Not attempted
Equivalent Force-Couple System: Circle	0/30 Not attempted
Equivalent Force-Couple System: Bracket	0/35 Not attempted
Resultant of a Force-Couple System	0/30 Not attempted

Created using Numbas v9.1, developed by Newcastle University.



Standalone
In Context

Chapter 5

Rigid Body Equilibrium

This chapter will investigate the equilibrium of simple rigid bodies like your book, phone, or pencil. The important difference between rigid bodies and the particles of [Chapter 3](#) is that rigid bodies have the potential to rotate around a point or axis, while particles do not.

For rigid body equilibrium, we need to maintain translational equilibrium with

$$\sum \mathbf{F} = 0 \quad (5.0.1)$$

and also maintain a balance of rotational forces and couple-moments with a new equilibrium equation

$$\sum \mathbf{M} = 0. \quad (5.0.2)$$

5.1 Degree of Freedom

Degrees of freedom refers to the number of independent parameters or values required to specify the *state* of an object.

The *state* of a *particle* is completely specified by its location in space, while the state of a rigid body includes its location in space and also its orientation.

Two-dimensional rigid bodies in the xy plane have three degrees of freedom. Position can be characterized by the x and y coordinates of a point on the object and orientation by angle θ_z about an axis perpendicular to the plane. The complete movement of the body can be defined by two linear displacements Δx and Δy , and one angular displacement $\Delta\theta_z$.

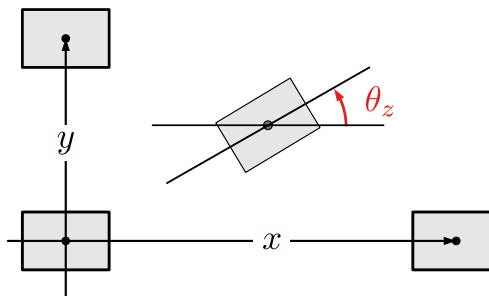

Figure 5.1.1 Two-dimensional rigid bodies have three degrees of freedom.

Three-dimensional rigid bodies have six degrees of freedom, which can be specified with three orthogonal coordinates x, y and z , and three angles of rotation, θ_x, θ_y and θ_z . Movement of the body is defined by three translations $\Delta x, \Delta y$ and Δz , and three rotations $\Delta\theta_x, \Delta\theta_y$ and $\Delta\theta_z$.

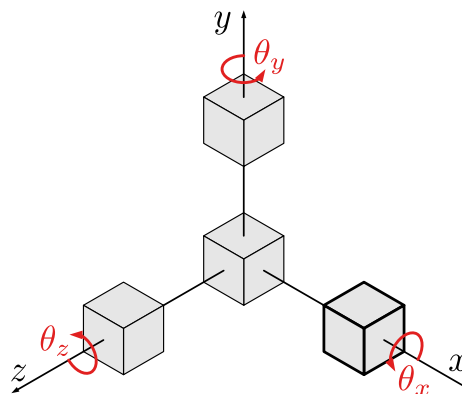

Figure 5.1.2 Three-dimensional rigid body have six degrees of freedom - three translations and three rotations.

For a body to be in static equilibrium, all possible movements must be adequately restrained. If a degree of freedom is not restrained, the body is in an unstable state, free to move in one or more ways. Stability is highly desirable for reasons of human safety, and bodies are often restrained by *redundant* restraints so that if one were to fail, the body would still remain stable. If the restraints correctly interpreted, then equal constraints and degrees of freedom create a stable system, and the values of the reaction forces and moments can be determined using equilibrium equations. If the number of restraints exceeds the number of degrees of freedom, the body is in equilibrium but you will need techniques we won't cover in statics to determine the reactions.

5.2 Free-Body Diagrams

Key Questions

- What are the five steps to create a free-body diagram?
- What are degrees of freedom, and how do they relate to stability?
- Which reaction forces and couple-moments come from each support type?
- What are the typical support force components and couple-moment components that can be modeled from the various types of supports?

Free body diagrams are the tool that engineers use to identify the forces and moments that influence an object. They will be used extensively in statics, and you will use them again in other engineering courses so your effort to master them now is worthwhile. Although the concept is simple, students often need help to draw them correctly.

Drawing a correct free-body diagram is the first and most important step

in the process of solving an equilibrium problem. It is the basis for all the equilibrium equations you will write; if your free-body diagram is incorrect, your equations, analysis, and solutions will also be wrong.

A quality free-body diagram is neat, clearly drawn, and contains all the information necessary to solve the equilibrium. You should take your time and think carefully about the free-body diagram before you begin to write and solve equations. A straightedge, protractor and colored pencils all can help. You will inevitably make mistakes that will lead to confusion or incorrect answers; you are encouraged to think about these errors and identify any misunderstandings to avoid them in the future.

Every equilibrium problem begins by drawing and labeling a free-body diagram!

Creating Free Body Diagrams. The basic process for drawing a free-body diagrams is

1. *Select and isolate an object.*

The “free-body” in free-body diagram means that the body to be analyzed must be free from the supports that are physically holding it in place.

Simply sketch a quick outline of the object as if it is floating in space disconnected from everything. Do *not* draw free-body diagram forces on top of your problem drawing — the body needs to be drawn free of its supports.

2. *Select a reference frame.*

Select a right-handed coordinate system to use as a reference for your equilibrium equations. Even if you are using a horizontal x axis and vertical y axis, indicate your coordinate system on your diagram.

Look ahead and select a coordinate system that minimizes the number of unknown force components in your equations. The choice is technically arbitrary, but a good choice will simplify your calculations and reduce your effort. If you and another student pick different reference systems, you should both get the same answer while expressing your work with different components.

3. *Identify all loads.*

Add vector arrows representing the applied forces and couple moments of acting on the body. These are often obvious. Include the body’s weight if it is non-negligible. If a vector has a known line of action, draw the arrow in that direction; if its sense is unknown, assume one. Every vector should have a descriptive variable name and a clear arrowhead indicating its direction.

4. *Identify all reactions.*

Traverse the perimeter of the object and wherever a support was removed when isolating the body, replace it with the forces and/or couple-moments which it provides. Label each reaction with a descriptive variable name and a clear arrowhead. Again, if a vector's direction is unknown just assume one.

The reaction forces and moments provided by common two-dimensional supports are shown in [Figure 5.2.1](#) and three dimensional support in [Figure 5.2.2](#). Identifying the correct reaction forces and couple-moments coming from supports is perhaps the most challenging step in the entire equilibrium process.

5. *Label the diagram.*

Verify that every dimension, angle, force, and moment is labeled with either a value or a symbolic name if the value is unknown. Supply the information needed for your calculations, but don't clutter the diagram up with unneeded information. This diagram should be a stand-alone presentation.

Drawing good free-body diagrams is surprisingly tricky and requires practice. Study the examples, think hard about them, do lots of problems, and learn from your errors.

Two-dimensional Reactions. Supports supply reaction forces and moment which prevent bodies from moving when loaded. In the most basic terms, forces prevent translation, and moments prevent rotation.

The reactions supplied by a support depend on the nature of the particular support. For example in a top view, a door hinge allows the door to rotate freely but prevents it from translating. We model this as a frictionless pin that supplies a perpendicular pair of reaction forces, but no reaction moment. We can evaluate all the other physical supports in a similar way to come up with the table below. You will notice that some two-dimensional supports only restrain one degree of freedom and others restrain up to three degrees of freedom. The number of degrees of freedom directly correlates to the number of unknowns created by the support.

The table below shows typical two-dimensional support methods and the corresponding reaction forces and moments supplied each.

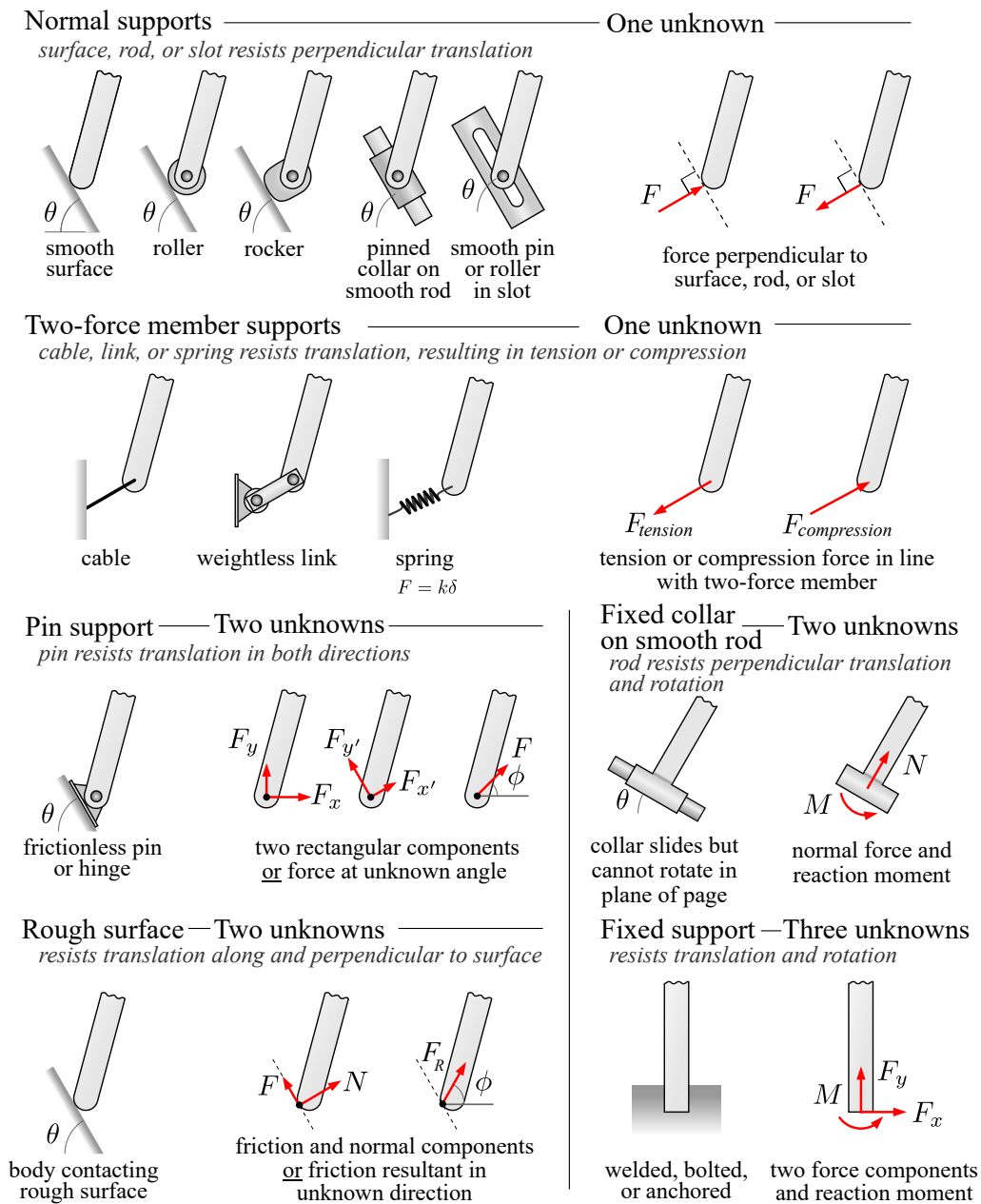

Figure 5.2.1 Table of common two-dimensional supports and their representation on free-body diagrams.

Three-dimensional Reactions. The main added complexity with three-dimensional objects is that there are more possible ways the object can move, and also more possible ways to restrain it. The table below show the types of supports which are available and the corresponding reaction forces and moment. As before, your free-body diagrams should show the reactions supplied by the constraints, not the constraints themselves.

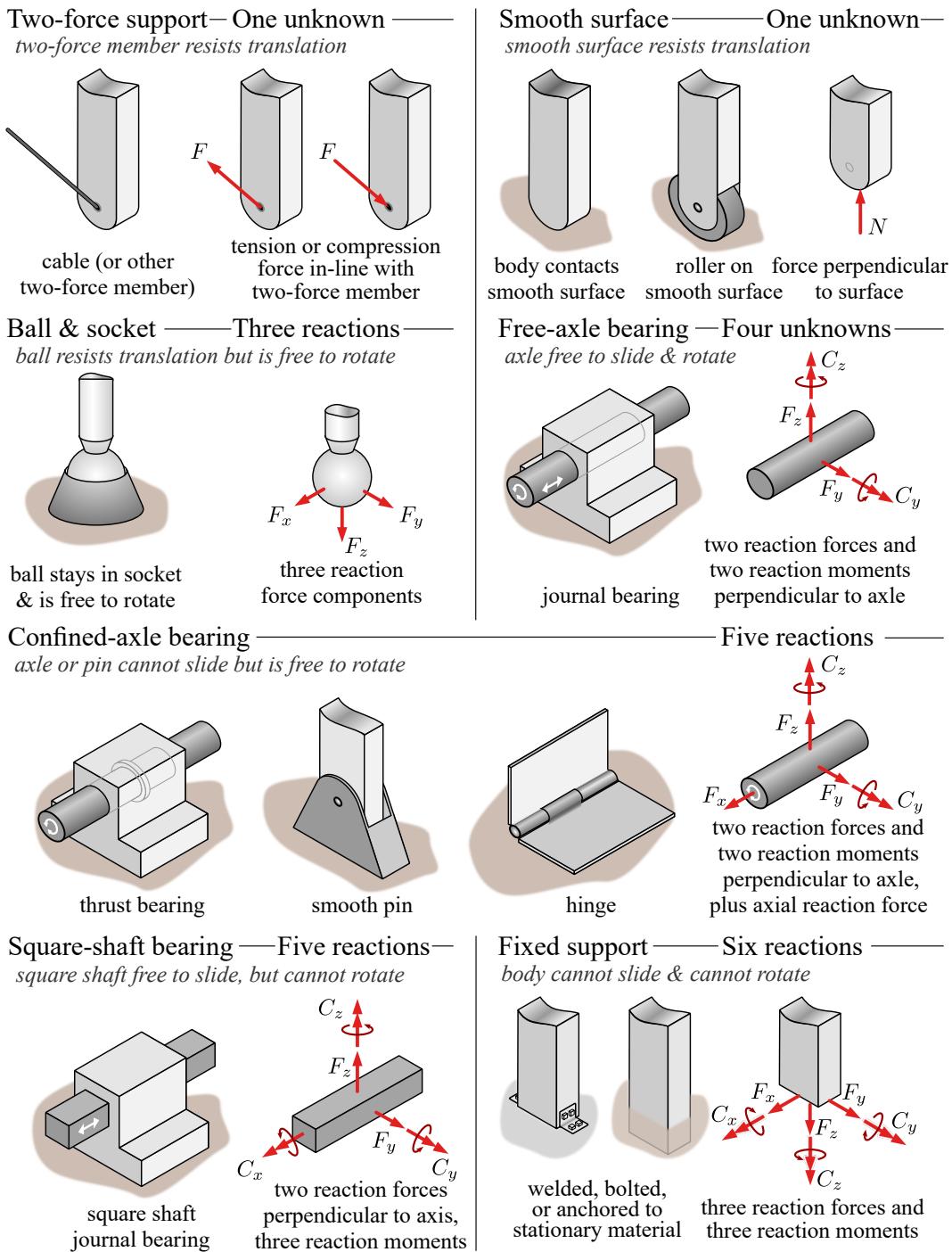

Figure 5.2.2 Table of common three-dimensional supports and their associated reactions.

One new issue we face in three-dimensional problems is that reaction couples may be **available** but not **engaged**.

A support which provides a non-zero reaction is said to be engaged. Picture a crate sitting at rest on a horizontal surface with a cable attached to the top of the crate. If the cable is slack, the reaction of the cable would be available but not *engaged*. Instead, the floor would be supporting the full weight of the

crate. If we were to remove the floor, the cable would be engaged and support the weight of the crate.

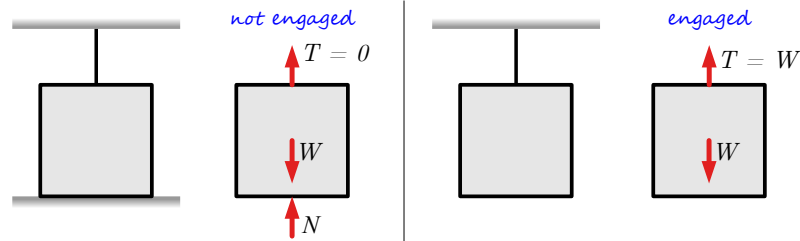

Figure 5.2.3 Available and Engaged reactions.

To get a feel for how reaction couples engage, pick up your laptop or a heavy book and hold it horizontally with your left hand. Can you feel your hand supplying an upward force to support the weight *and* a counter-clockwise reaction couple to keep it horizontal? Now add a similar support by gripping with your right hand. How do the forces and couple-moments change? You should have felt the force of your left hand decrease as your right hand picked up half the weight, and also noticed that the reaction couple from your left hand was no longer needed.

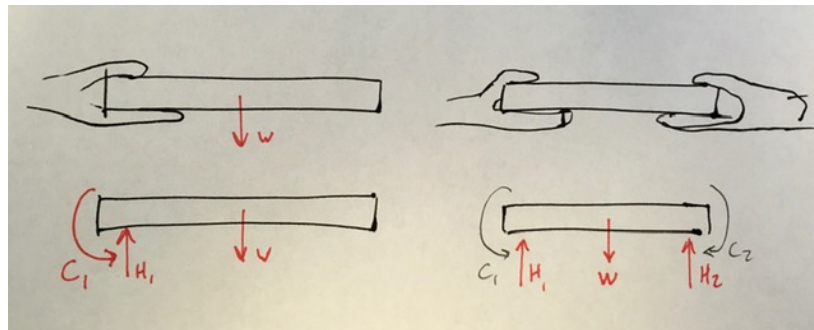

Figure 5.2.4 One hand holding an object versus two hands holding the same object.

The vertical force in your right hand engaged instead of the couple-moment of your left hand. The reaction couples from both hands are available, but the vertical forces engage first and are sufficient for equilibrium. This phenomena is described by the saying “reaction forces engage before reaction couple-moments”.

Free-Body Diagram Examples. Given that there several options for representing reaction forces and couple-moments from a support, there are different, equally valid options for drawing free-body diagrams. With experience you will learn which representation to choose to simplify the equilibrium calculations.

Possible free-body diagrams for two common situations are shown in the next two examples.

Example 5.2.5 Fixed support.

The cantilevered beam is embedded into a fixed vertical wall at A . Draw a neat, labeled, correct free-body diagram of the beam and identify the knowns and the unknowns.

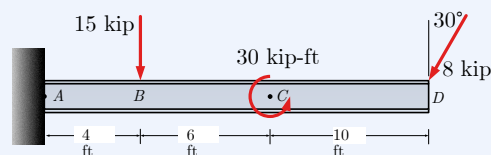
**Solution.**

Begin by drawing a neat rectangle to represent the beam disconnected from its supports, then add all the known forces and couple-moments. Label the magnitudes of the loads and the known dimensions symbolically.

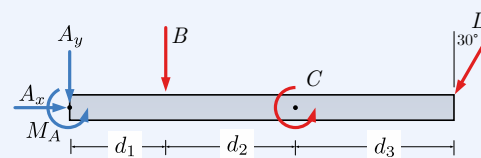

Choose the standard xy coordinate system, since it aligns well with the forces.

The wall at A is a fixed support which prevents the beam from translating up, down, left or right, or rotating in the plane of the page. These constraints are represented by two perpendicular forces and a concentrated moment, as shown in Figure 5.2.1. Label these unknowns as well.

The knowns in this problem are the magnitudes and directions of moment C , forces B , and D and the dimensions of the beam. The unknowns are the two force components A_x and A_y and the scalar moment M_A caused by the fixed connection. If you prefer, you may represent force A as a force of unknown magnitude acting at an unknown direction. Whether you represent it as x and y components or as a magnitude and direction, there are two unknowns associated with force A .

The three unknown reactions can be found using the three independent equations of equilibrium we will discuss later in this chapter.

Example 5.2.6 Frictionless pin and roller.

The beam is supported by a frictionless pin at A and a rocker at D . Draw a neat, labeled, correct free-body diagram of the beam and identify the knowns and the unknowns.

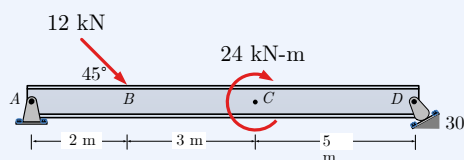

Solution. In this problem, the knowns are the magnitude and direction of force B and moment C and the dimensions of the beam.

The constraints are the frictionless pin at A and the rocker at D . The pin prevents translation but not rotation, which means it has two

unknowns, represented by either magnitude and direction, or by two orthogonal components. The rocker provides a force perpendicular to the surface it rests on, which is 30° from the horizontal. This means that the line of action of force \mathbf{D} is 30° from the vertical, giving us its direction but not its sense or magnitude

To draw the free-body diagram, start with a neat rectangle to representing the beam disconnected from its supports, then draw and label known force B and moment C and the dimensions.

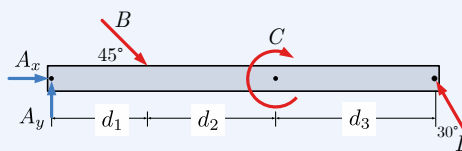

Add forces A_x and A_y representing vector \mathbf{A} and force \mathbf{D} at D , acting 30° from the vertical.

When a force has a known line of action as with force \mathbf{D} , draw it acting along that line; don't break it into components. When it is not obvious which way a reaction force actually points along its lines of action, just make your best guess and place an arrowhead accordingly. Your calculations will confirm or refute your guess later.

As in the previous example, you could alternately represent force \mathbf{A} as an unknown magnitude acting in an unknown direction, though there is no particular advantage to doing so in this case.

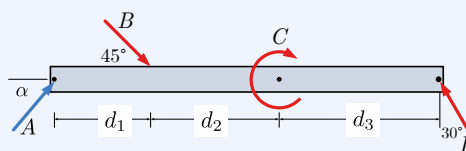

5.3 Equations of Equilibrium

Key Questions

- What is the definition of static equilibrium?
- How do I choose which are the most efficient equations to solve two-dimensional equilibrium problems?

In statics, our focus is on systems where both linear acceleration \mathbf{a} and angular acceleration α are zero. These systems are frequently stationary, but could be moving with constant velocity.

Under these conditions [Newton's Second Law for translation](#) reduces to

$$\sum \mathbf{F} = 0, \quad (5.3.1)$$

and, [Newton's second law for rotation](#) gives the similar equation

$$\sum \mathbf{M} = 0. \quad (5.3.2)$$

The first of these equations requires that all forces acting on an object balance and cancel each other out, and the second requires that all moments balance as well. Together, these two equations are the mathematical basis of this course and are sufficient to evaluate equilibrium for systems with up to six degrees of freedom.

These are vector equations; hidden within each are three independent scalar equations, one for each coordinate direction.

$$\sum \mathbf{F} = 0 \implies \begin{cases} \Sigma F_x = 0 \\ \Sigma F_y = 0 \\ \Sigma F_z = 0 \end{cases} \quad \sum \mathbf{M} = 0 \implies \begin{cases} \Sigma M_x = 0 \\ \Sigma M_y = 0 \\ \Sigma M_z = 0 \end{cases} \quad (5.3.3)$$

Working with these scalar equations is often easier than using their vector equivalents, particularly in two-dimensional problems.

In many cases we do not need all six equations. We saw in [Chapter 3](#) that particle equilibrium problems can be solved using the force equilibrium equation alone, because particles have, at most, three degrees of freedom and are not subject to any rotation.

To analyze rigid bodies, which can rotate as well as translate, the moment equations are needed to address the additional degrees of freedom. Two-dimensional rigid bodies have only one degree of rotational freedom, so they can be solved using just one moment equilibrium equation, but to solve three-dimensional rigid bodies, which have six degrees of freedom, all three moment equations and all three force equations are required.

5.4 2D Rigid Body Equilibrium

Two-dimensional rigid bodies have three degrees of freedom, so they only require three independent equilibrium equations to solve. The six scalar equations of [\(5.3.3\)](#) can easily be reduced to three by eliminating the equations which refer to the unused z dimension. For objects in the xy plane there are no forces acting in the z direction to create moments about the x or y axes, so the reduced set of three equations is

$$\{1\} = \begin{cases} \Sigma F_x = 0 \\ \Sigma F_y = 0 \\ \Sigma M_A = 0 \end{cases}$$

where the subscript z has been replaced with a letter to indicate an arbitrary moment center in the xy plane instead of a perpendicular z axis.

This is not the only possible set of equilibrium equations. Either force equation can be replaced with a linearly independent moment equation about a point

of your choosing ¹, so the other possible sets are

$$\{2\} = \begin{cases} \sum F_x = 0 \\ \sum M_B = 0 \\ \sum M_A = 0 \end{cases} \quad \{3\} = \begin{cases} \sum M_C = 0 \\ \sum F_y = 0 \\ \sum M_A = 0 \end{cases} \quad \{4\} = \begin{cases} \sum M_C = 0 \\ \sum M_B = 0 \\ \sum M_A = 0 \end{cases}$$

For set four, moment centers A , B , and C must form a triangle to ensure the three equations are linearly independent.

You have a lot of flexibility when solving rigid-body equilibrium problems. In addition to choosing which set of equations to use, you are also free to rotate the coordinate system to any orientation you like, pick different points for moment centers, and solve the equations in any order or simultaneously.

This freedom raises several questions. Which equation set should you choose? Is one choice ‘better’ than another? Why bother rotating coordinate systems? How do you select moment centers? Students want to know “how to solve the problem,” when in reality there are many ways to do it.

The actual task is to choose an efficient approach and carry it out. An efficient solution is one which avoids mathematical complications and makes the problem easy to solve. Complications include unpleasant geometries, unnecessary algebra, and particularly simultaneous equations, which are algebra intensive and error prone.

So how do you set up an efficient approach? First, stop, think, and look for opportunities to make the solution more efficient. Here are some recommendations.

1. Equation set one is usually a good choice and should be considered first.
2. Inspect your free-body diagram and identify the unknown values in the problem. These may be magnitudes, directions, angles or dimensions.
3. Align the coordinate system with at least one unknown force.
4. Take moments about the point where the lines of action of two unknown forces intersect, which eliminates them from the equation.
5. Solve equations with one unknown first.

¹Labels A , B and C in these equations are representative. They don’t have to correspond to points A , B and C on your problem.

Example 5.4.1 Pin and Roller.

The L-shaped body is supported by a roller at B and a frictionless pin at A . The body supports a 250 lb vertical force at C and a 500 ft·lb couple-moment at D . Determine the reactions at A and B .

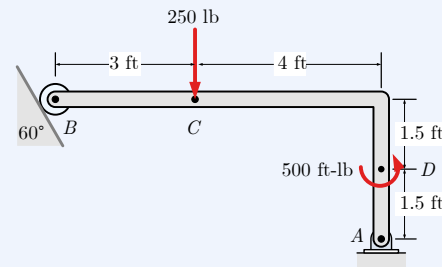

This problem will be solved three different ways to demonstrate the advantages and disadvantages of different approaches.

Solution 1.

Solutions always start with a free-body diagram, showing all forces and moments acting on the object. Here, the known loads $C = 250$ lb (down) and $D = 500$ ft·lb (CCW) are red, and the unknown reactions A_x , A_y and B are blue.

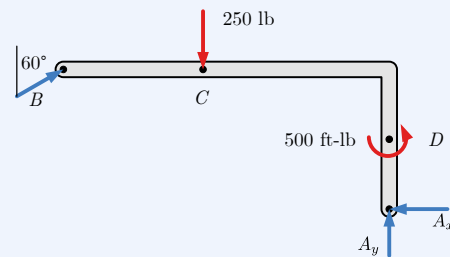

The force at B is drawn along its known line-of-action perpendicular to the roller surface, and drawn pointing up and right because that will oppose the rotation of the frame about A caused by load C and moment D . The force at A is represented by unknown components A_x and A_y . The sense of these components is unknown, so we have arbitrarily assigned the arrowheads pointing left and up.

We have chosen the standard coordinate system with positive x to the right and positive y pointing up, and resolved force A into components in the x and y directions.

The magnitude of force B is unknown but its direction is known, so the x and y components of B can be expressed as

$$B_x = B \sin 60^\circ \qquad B_y = B \cos 60^\circ$$

We choose to solve equation set $\{A\}$, and choose to take moments about point A , because unknowns A_x and A_y intersect there. Substituting the variables into the equation and solving for the unknowns gives

$$\begin{aligned} \sum F_x &= 0 \\ B_x - A_x &= 0 \\ A_x &= B \sin 60^\circ \end{aligned} \qquad (1)$$

$$\begin{aligned}\sum F_y &= 0 \\ B_y - C + A_y &= 0 \\ A_y &= C - B \cos 60^\circ\end{aligned}\quad (2)$$

$$\begin{aligned}\sum M_A &= 0 \\ -B_x(3) - B_y(7) + C(4) + D &= 0 \\ 3B \cos 60^\circ + 7B \sin 60^\circ &= 4C + D \\ B(3 \sin 60^\circ + 7 \cos 60^\circ) &= 4C + D \\ B &= \frac{4C + D}{6.098}\end{aligned}\quad (3)$$

Of these three equations only the third can be evaluated immediately, because we know C and D . In equations (1) and (2) unknowns A_x and A_y can't be found until B is known. Inserting the known values into (3) and solving for B gives

$$\begin{aligned}B &= \frac{4(250) + 500}{6.098} \\ &= \frac{1500 \text{ ft}\cdot\text{lb}}{6.098 \text{ ft}} \\ &= 246.0 \text{ lb}\end{aligned}$$

Now with the magnitude of B known, A_x and A_y can be found with (1) and (2).

$$\begin{aligned}A_x &= B \sin 60^\circ \\ &= 246.0 \sin 60^\circ \\ &= 213.0 \text{ lb}\end{aligned}$$

$$\begin{aligned}A_y &= C - B \cos 60^\circ \\ &= 250 - 246.0 \cos 60^\circ \\ &= 127.0 \text{ lb}\end{aligned}$$

The positive signs on these values indicate that the directions assumed on the free-body diagram were correct.

The magnitude and direction of force \mathbf{A} can be found from the scalar components A_x and A_y using a rectangular to polar conversion.

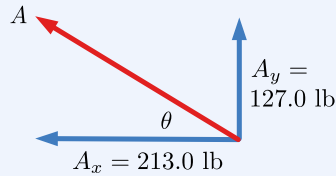

$$A = \sqrt{A_x^2 + A_y^2} = 248.0 \text{ lb}$$

$$\theta = \tan^{-1} \left| \frac{A_y}{A_x} \right| = 30.8^\circ$$

The final values for \mathbf{A} and \mathbf{B} , with angles measured counter-clockwise from the positive x axis are

$$\mathbf{A} = 248.0 \text{ lb} \angle 149.2^\circ,$$

$$\mathbf{B} = 246.0 \text{ lb} \angle 30^\circ.$$

This solution demonstrates a fairly standard approach appropriate for many statics problems which should be considered whenever the free-body diagram contains a frictionless pin. Start by taking moments there.

Solution 2.

In this solution, we have rotated the coordinate system 30° to align it with force \mathbf{B} and also chosen the components of force \mathbf{A} to align with the new coordinate system.

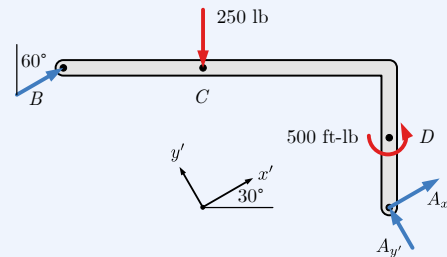

There is no particular advantage to this approach over the first one, but with two unknown forces aligned with the x' direction, $A_{y'}$ can be found directly after breaking force C into components.

$$\begin{aligned} \sum F_{x'} &= 0 \\ B - C_{x'} + A_{x'} &= 0 \\ A_{x'} &= -B + C \sin 30^\circ \end{aligned} \quad (1)$$

$$\begin{aligned} \sum F_{y'} &= 0 \\ -C_{y'} + A_{y'} &= 0 \\ A_{y'} &= C \cos 30^\circ \end{aligned} \quad (2)$$

$$\begin{aligned} \sum M_A &= 0 \\ -B_x(3) - B_y(7) + C(4) + D &= 0 \\ 3B \cos 60^\circ + 7B \sin 60^\circ &= 4C + D \\ B(3 \cos 60^\circ + 7 \sin 60^\circ) &= 4C + D \end{aligned}$$

$$B = \frac{4C + D}{7.56} \quad (3)$$

Solving equation (2) yields

$$A_{y'} = 216.5 \text{ lb.}$$

Solving equation (3) yields the same result as previously

$$B = 246.0 \text{ lb.}$$

Substituting B and C into equation (1) yields

$$\begin{aligned} A_{x'} &= -B + C \sin 30^\circ \\ &= -246.0 + 250 \sin 30^\circ \\ &= -121.0 \text{ lb} \end{aligned}$$

The negative sign on this result indicates that our assumed direction for $A_{x'}$ was incorrect, and that force actually points 180° to the assumed direction.

Resolving the $A_{x'}$ and $A_{y'}$ gives the magnitude and direction of force \mathbf{A} .

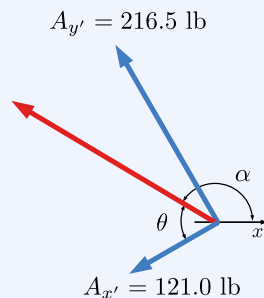

$$A = \sqrt{A_{x'}^2 + A_{y'}^2} = 248.0 \text{ lb}$$

$$\theta = \tan^{-1} \left| \frac{A_{y'}}{A_{x'}} \right| = 60.8^\circ$$

$$\alpha = 180^\circ - (\theta - 30^\circ) = 149.2^\circ$$

Again, the final values for \mathbf{A} and \mathbf{B} , with angles measured counter-clockwise from the positive x axis are

$$\mathbf{A} = 248.0 \text{ lb} \angle 149.2^\circ,$$

$$\mathbf{B} = 246.0 \text{ lb} \angle 30^\circ$$

This approach was slightly more difficult than solution one because of the additional trigonometry involved to find components in the rotated coordinate system.

Solution 3.

For this solution, we will use the same free-body diagram as solution one, but will use three moment equations, about points B , C and D .

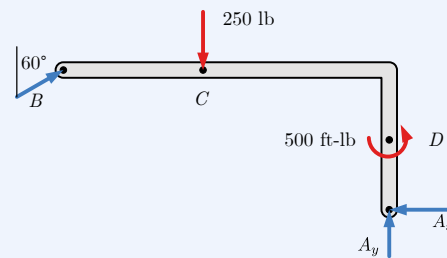

$$\begin{aligned}
 \sum M_B &= 0 \\
 -A_x(3) + A_y(7) - C(3) + D &= 0 \\
 -3A_x + 7A_y &= 250
 \end{aligned} \tag{1}$$

$$\begin{aligned}
 \sum M_C &= 0 \\
 -A_x(3) + A_y(4) - B_y(3) + D &= 0 \\
 -3A_x + 4A_y - 3B \cos 60^\circ &= -D \\
 3A_x - 4A_y + 1.5B &= 500
 \end{aligned} \tag{2}$$

$$\begin{aligned}
 \sum M_D &= 0 \\
 -A_x(1.5) - B_x(1.5) - B_y(7) + C(4) + D &= 0 \\
 1.5A_x + 1.5B \sin 60^\circ + 7B \cos 60^\circ &= 4C + D \\
 1.5A_x + 4.799B &= 1500
 \end{aligned} \tag{3}$$

This set of three equations and three unknowns can be solved with some algebra.

Adding (1) and (2) gives

$$3A_y + 1.5B = 750 \tag{4}$$

Dividing equation (2) by 2 and subtracting it from (3) gives

$$2A_y + 4.049B = 1250 \tag{5}$$

Multiplying (4) by 2/3 and subtracting from (5) eliminates A_y and gives

$$3.049B = 750$$

$$B = 246.0 \text{ lb}$$

, the same result as before.

Substituting B into (3) gives $A_x = 213.0$ lb, and substituting this into (1) gives $A_y = 127.0$ lb, again the same result as before.

An alternate approach is to set these three equations up for a matrix solution and use technology to do the algebra, as done here with Sage.

$$\begin{bmatrix} -3 & 7 & 0 \\ 3 & -4 & 1.5 \\ 1.5 & 0 & 4.799 \end{bmatrix} \begin{bmatrix} A_x \\ A_y \\ B \end{bmatrix} = \begin{bmatrix} 250 \\ 500 \\ 1500 \end{bmatrix}$$

```
A = Matrix([[[-3,7,0],[3,-4, 1.5],[1.5,0,4.799]])
B = vector([250, 500, 1500])
x = A.solve_right(B)
x
```

```
(213.020662512299, 127.008855362414, 245.982289275172)
```

This is a good example of an inefficient solution because of all the algebra involved. The issue here was the poor choice of B , C and D as moment centers. Whenever possible you should take moments about a point where the line of action of two unknowns intersect as was done in solution one. This gives a moment equation which can be solved immediately for the third unknown.

5.5 3D Rigid Body Equilibrium

Key Questions

- What are the similarities and differences between solving two-dimensional and three-dimensional equilibrium problems?
- Why are some three-dimensional reaction couple-moments “available but not engaged”?
- What kinds of problems are solvable using linear algebra?

Three-dimensional systems are closer to reality than two-dimensional systems and the basic principles to solving both are the same, however they are generally harder solve because of the additional degrees of freedom involved and the difficulty visualizing and determining distances, forces and moments in three dimensions.

Three-dimensional problems are usually solved using vector algebra rather than the scalar approach used in the last section. The main differences are that directions are described with unit vectors rather than with angles, and moments are determined using the vector cross product rather scalar methods. Because they have more possible unknowns it is harder to find efficient equations to solve by hand. A problem might involve solving a system of up to six equations and six unknowns, in which case it is best solved using linear algebra and technology.

Resolving Forces and Moments into Components. To break two-dimensional forces into components, you likely used right-triangle trigonometry, sine and cosine. However, three-dimensional forces will likely need to be broken into components using [Section 2.5](#).

When summing moments, make sure to consider both the $\mathbf{r} \times \mathbf{F}$ moments and also the couple-moments with the following guidance:

1. First, choose any point in the system to sum moments around.
2. There are two general methods for summing the $\mathbf{r} \times \mathbf{F}$ moments. Both techniques will give you the same set of equations.

(a) *Sum moments around each axis.*

For relatively simple systems with few position and force vector components, you can find the cross product for each non-parallel position and force pair. Using this method requires you to resolve the direction of each cross product pair using the right-hand rule as covered in [Chapter 4](#). Recall that there are up to six pairs of non-parallel components that you need to consider.

(b) *Sum all moments around a point using vector determinants.*

Choose a point in the system which is on the line of action of as many forces as possible, then set up each cross product as a determinant. After computing the components coming from each determinant, combine the x , y , and z terms into each of the $\Sigma \mathbf{M}_x = 0$, $\Sigma \mathbf{M}_y = 0$, and $\Sigma \mathbf{M}_z = 0$ equations.

3. Finally, add the components of any couple-moments into the corresponding $\Sigma \mathbf{M}_x = 0$, $\Sigma \mathbf{M}_y = 0$, and $\Sigma \mathbf{M}_z = 0$ equations.

Solving for unknown values in equilibrium equations. Once you have formulated $\Sigma \mathbf{F} = 0$ and $\Sigma \mathbf{M} = 0$ equations in each of the x , y and z directions, you could be facing up to six equations and six unknown values.

Frequently these simultaneous equation sets can be solved with substitution, but it is often be easier to solve large equation sets with linear algebra. Note that the adjective “linear” specifies that the unknown values must be linear terms, which means that each unknown variable cannot be raised to a exponent, be an exponent, or buried inside of a sin or cos function. Luckily, most unknowns in equilibrium are linear terms, except for unknown angles. If you are not familiar with the use of linear algebra matrices to solve simultaneously equations, search the internet for *Solving Systems of Equations Using Linear Algebra* and you will find plenty of resources.

No matter how you choose to solve for the unknown values, any numeric values which come out to be negative indicate that your initial hypothesis of that vector’s sense was incorrect.

Three-dimensional Equilibrium Examples.

Example 5.5.1 3D Bent Bar.

The bent bar shown is held in a horizontal plane by a fixed connection at C while cable AB exerts a 500 lb force on point A . Given $A = (4, 4, 5)$, $B = (6, 0, 4)$ and $C = (0, 4, 0)$.

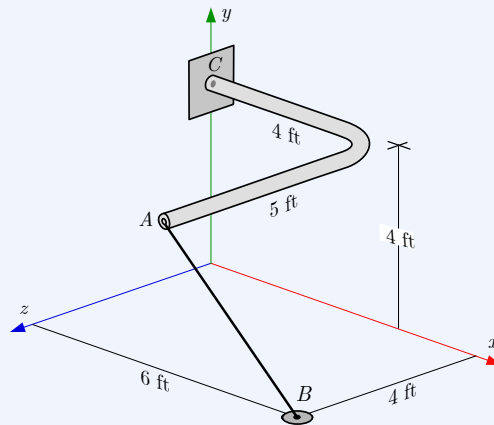

Find the reaction force \mathbf{C} and concentrated moment \mathbf{M} with components M_x , M_y and M_z required to hold the bar in this position under this condition.

Solution.

1. Draw a free-body diagram.

As always, begin by drawing a free-body diagram.

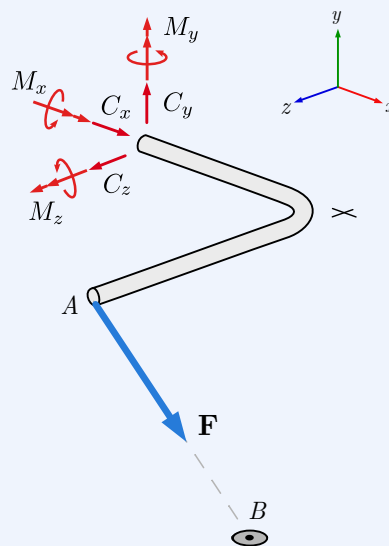

2. Determine the force acting at point A in Cartesian form.

The force of the cable acts from A to B . This direction is described

by the displacement vector from A to B

$$\mathbf{r}_{AB} = (2\mathbf{i} - 4\mathbf{j} - 1\mathbf{k}) \text{ ft}$$

or the corresponding unit vector

$$\begin{aligned} \lambda_{AB} &= \frac{\mathbf{r}_{AB}}{|\mathbf{r}_{AB}|} \\ &= \frac{2\mathbf{i} - 4\mathbf{j} - 1\mathbf{k}}{\sqrt{(2)^2 + (-4)^2 + (-1)^2}} \\ &= \frac{2\mathbf{i} - 4\mathbf{j} - 1\mathbf{k}}{\sqrt{21}}. \end{aligned}$$

Multiplying the unit vector by the cable tension gives the force acting on A as a three-dimensional Cartesian force vector.

$$\begin{aligned} \mathbf{F} &= \lambda_{AB}T \\ &= \left(\frac{2\mathbf{i} - 4\mathbf{j} - 1\mathbf{k}}{\sqrt{21}} \right) 500 \text{ lb} \\ &= (2\mathbf{i} - 4\mathbf{j} - 1\mathbf{k}) \left(\frac{500}{\sqrt{21}} \right) \text{ lb} \end{aligned}$$

$$\mathbf{F} = (218\mathbf{i} - 436\mathbf{j} - 109\mathbf{k}) \text{ lb}$$

3. Determine the moment about C .

The moment about point C is found with the [cross product \(4.3.4\)](#) where the moment arm is the displacement vector from C to A .

$$\mathbf{r}_{CA} = (4\mathbf{i} + 0\mathbf{j} + 5\mathbf{k}) \text{ ft}$$

$$\begin{aligned} \mathbf{M}_C &= \mathbf{r}_{CA} \times \mathbf{F} \\ &= \begin{vmatrix} \mathbf{i} & \mathbf{j} & \mathbf{k} \\ 4 & 0 & 5 \\ 2 & -4 & -1 \end{vmatrix} \left(\frac{500}{\sqrt{21}} \right) \end{aligned}$$

$$\mathbf{M}_C = (2182\mathbf{i} + 1528\mathbf{j} - 1746\mathbf{k}) \text{ ft}\cdot\text{lb}$$

4. Apply the equations of equilibrium.

$$\Sigma \mathbf{F} = 0 \quad \left\{ \begin{array}{l} \Sigma F_x = 0 : C_x + F_x = 0 \\ C_x = -218 \text{ lb} \\ \Sigma T_y = 0 : C_y - F_y = 0 \\ C_y = +436 \text{ lb} \\ \Sigma T_z = 0 : C_z - F_z = 0 \\ C_z = +109 \text{ lb} \end{array} \right.$$

$$\Sigma \mathbf{M} = 0 \quad \left\{ \begin{array}{l} \Sigma M_x = 0 : M_x + M_{C_x} = 0 \\ M_x = -2182 \text{ ft}\cdot\text{lb} \\ \Sigma M_y = 0 : M_y + M_{C_y} = 0 \\ M_y = -1528 \text{ ft}\cdot\text{lb} \\ \Sigma M_z = 0 : M_z + M_{C_z} = 0 \\ M_z = +1746 \text{ ft}\cdot\text{lb} \end{array} \right.$$

The resulting vector equations for the reaction force \mathbf{C} and reaction moment \mathbf{M} are

$$\begin{aligned} \mathbf{C} &= (-218\mathbf{i} + 436\mathbf{j} + 109\mathbf{k}) \text{ lb} \\ \mathbf{M} &= (-2182\mathbf{i} - 1528\mathbf{j} + 1746\mathbf{k}) \text{ ft}\cdot\text{lb}. \end{aligned}$$

5.6 Stability and Determinacy

Key Questions

- What does *stable* mean for a rigid body?
- What does *determinate* mean for a rigid body?
- Does stability depend on the external loads or only on the reactions?
- How can I tell if a system is determinate?
- How can I decide if a problem is both stable and determinate, which makes it solvable statics?

Determinate vs. Indeterminate. A static system is **determinate** if it is possible to find the unknown reactions using the methods of statics, that is, by using equilibrium equations, otherwise it is **indeterminate**.

In order for a system to be determinate the number of unknown force and moment reaction components must be less than or equal to the number of independent equations of equilibrium available. Each equilibrium equation derives from a degree of freedom of the system, so there may be no more unknowns than degrees of freedom. This means that we can determine no more than three unknown reaction components in two-dimensional systems and no more than six in three-dimensional systems.

An indeterminate system with fewer reaction components than degrees of freedom is **under-constrained** and therefore unstable. On the other hand, if there are more reaction components than degrees of freedom, the system is both **over-constrained** and **indeterminate**. In terms of force and moment equations, there are more unknowns than equilibrium equations so they can't all be determined. This is not to say that it is impossible to find all reaction force on an over-constrained system, just that you will not learn how to find them in this course.

Stable vs. Unstable. A body in equilibrium is held in position by its supports, which restrict the body's motion and counteract the applied loads. When there are sufficient supports to restrain a body from moving, we say that the body is **stable**. A stable body is prevented from translating and rotating in all directions. A body which *can* move is **unstable** even if it is not currently moving, because the slightest change in load may take it out of equilibrium and initiate motion. Stability is loading independent i.e. a stable body is stable for *any* loading condition.

Rules to Validate a Stable and Determinate System. There are three rules to determine if a system is both stable and determinate. While, the rules below can technically be checked in any order, they have been sorted from the quickest to the most time consuming to speed up your analysis.

Rule 1: Are there exactly three reaction components on a two-dimensional body?

If YES, the system is determinate.

If NO, the system is indeterminate or not stable.

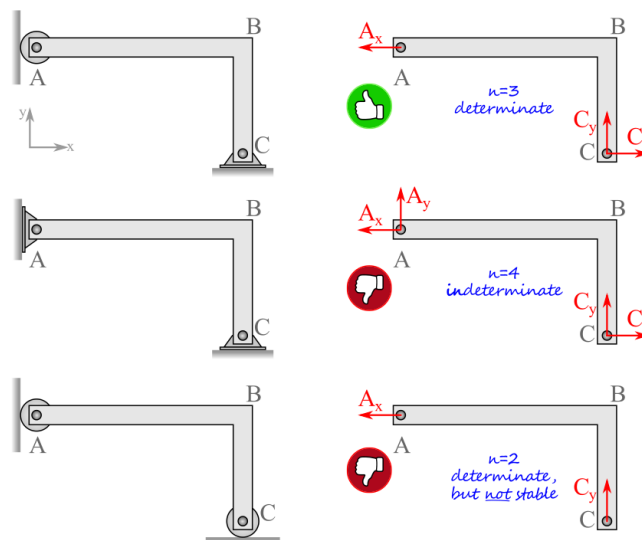

Rule 2: Are all the reaction force components parallel to one another?

If YES, the system is unstable for translation.

If NO, the system is stable for translation.

Rule 3: Do the lines of action of the reaction forces intersect at a single point?

If YES, the system is unstable for rotation about the single intersection point.

If NO, the system is stable for rotation.

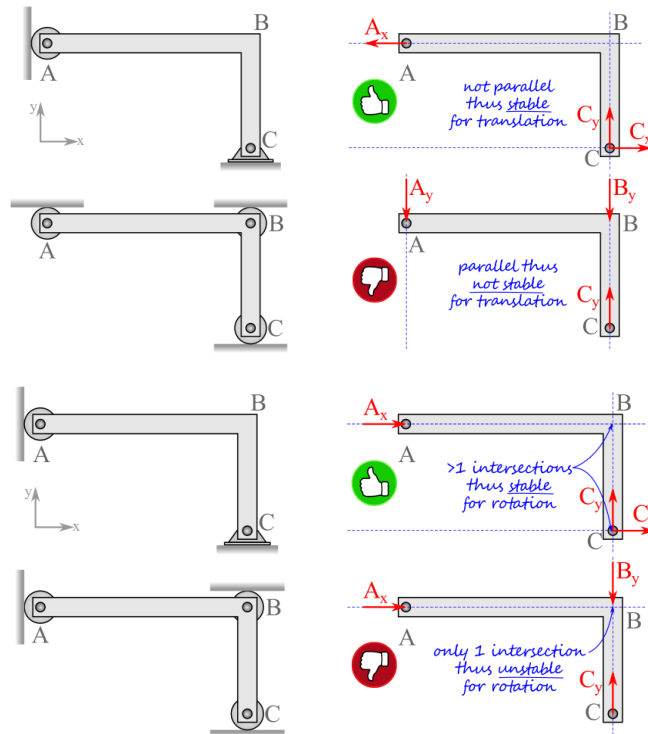

5.7 Equilibrium Examples

You can use these interactives to explore how the reactions supporting rigid bodies are affected by the loads applied. You can use the equations of equilibrium to solve for the unknown reactions, and check your work.

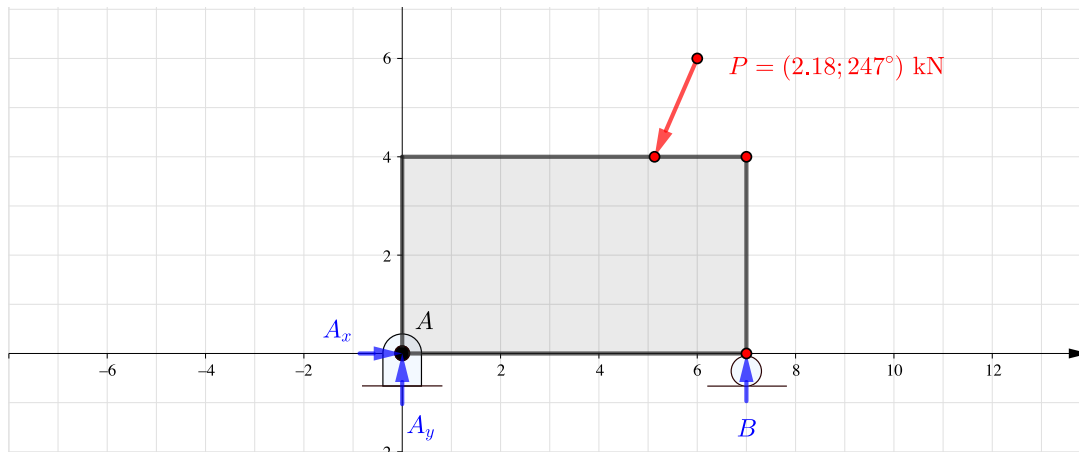

[Live Link](#)

Figure 5.7.1 Rigid body Equilibrium

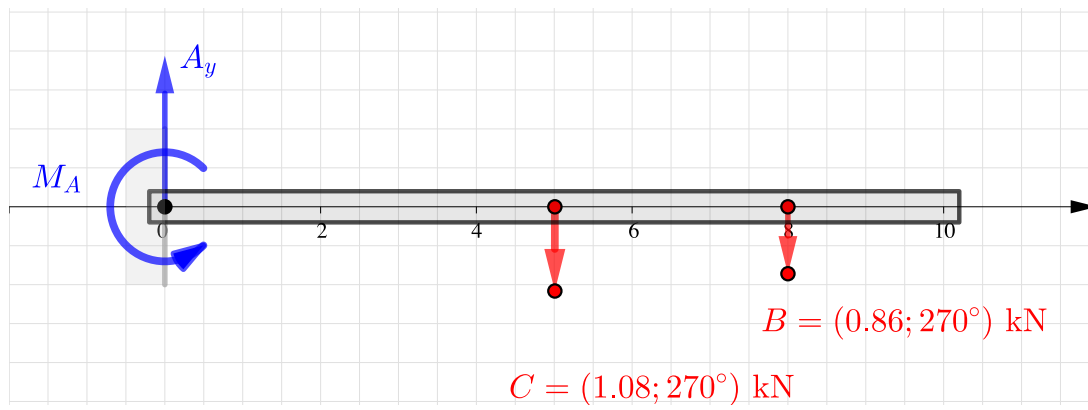

Live Link

Figure 5.7.2 Cantilever beam

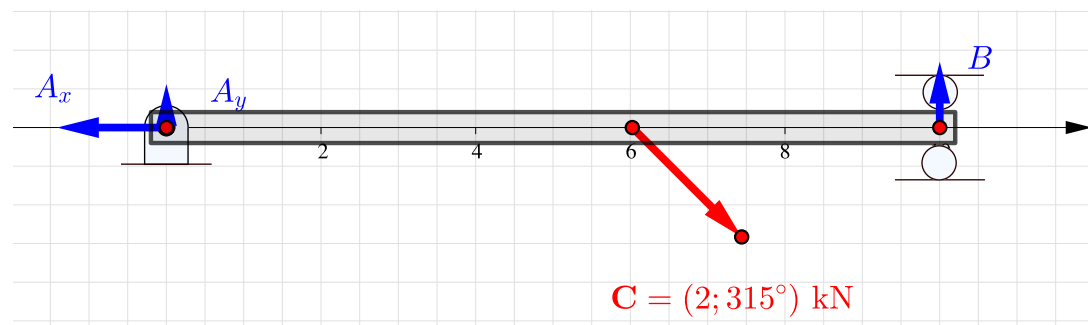

Live Link

Figure 5.7.3 Beam with concentrated load

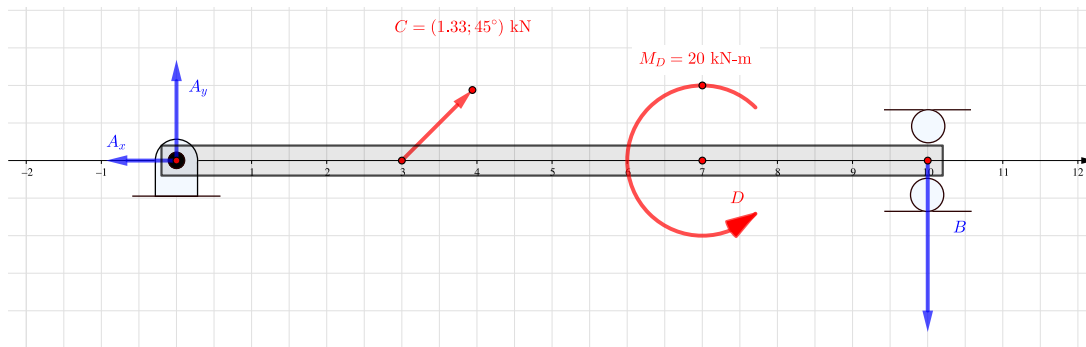

Live Link

Figure 5.7.4 Beam with concentrated force and couple moment

5.8 Exercises (Ch. 5)

Chapter 5 Exercises

Rigid Body Equilibrium	0/369
Tension in a Cable	0/4
	Not attempted
Inclined Bar and cable	0/20
	Not attempted
Isosceles Triangular Plate	0/30
	Not attempted
Truss	0/60
	Not attempted
Raise Pole	0/30
	Not attempted
Triangle	0/50
	Not attempted
Cantilever Beam	0/35
	Not attempted
Beam and Pulley	0/40
	Not attempted
Bell Crank	0/30
	Not attempted
Car on a Hill	0/20
	Not attempted
Hand Truck	0/20
	Not attempted
Dump Truck	0/30
	Not attempted
Three-force Body Method	0/55
Beam with Angled Load	0/20
	Not attempted
Triangle	0/35
	Not attempted

Display options

Done

Created using [Numbas v9.1](#), developed by [Newcastle University](#).



Standalone
In Context

Chapter 6

Equilibrium of Structures

In this chapter, you will conduct static analysis of multi-body structures. Broadly defined, a structure is any set of interconnected rigid bodies designed to serve a purpose. The parts of the structure may move relative to one another, like the blades of scissors, or they may be fixed relative to one another, like the structural members of a bridge.

Analysis of structures involves determining all forces acting on and between individual members of the structure. Fundamentally there is nothing new here; the techniques you have already learned apply, however, structures tend to have more unknown forces, and so are more involved and provide more opportunities for error than the problems you have previously encountered. Correct free-body diagrams and careful work are required, as always.

6.1 Structures

Structures fall into three broad categories: trusses, frames, and machines, and you should be able to identify which is which.

A **truss** is a multi-body structure made up of long slender members connected at their ends in triangular subunits. Truss members carry axial forces only. Trusses are commonly used for spanning large distances without interruption: bridges, roof systems, stadiums, aircraft hangers, auditoriums for example. They are also used for crane booms, radio towers and the like. Trusses are lightweight and relatively strong. Over the years many unique truss designs have been developed and are often named after the original designer.

A **frame** is a multi-part, rigid, stationary structure primarily designed to support some type of load. A frame contains at least one multi-force member, which a truss never has. This means that, unlike trusses, frame members must support bending moments as well as shear and normal forces. Many common items can be considered frames. Some examples: building structures, bike frames, ladders, scaffolding, and more.

A **machine** is very similar to a frame, except that it includes some moving parts. The purpose of a machine is usually to provide a mechanical advantage

and multiply forces. Pliers, scissors jacks, automobile suspensions, and construction equipment are all examples of machines.



Figure 6.1.1 Scissors and bridges are examples of engineering structures. Scissors are machines with three interconnected parts. The bridge is a truss.

Solving a structure means determining all forces acting on all of its parts. The solution typically begins by determining the global equilibrium of the entire structure, then breaking it into parts and analyzing each separate part. The specific process will depend on the type of structure, but will always follow the principles covered in the previous chapters.

Two-force Members. Many structures contain at least one two-force member, and trusses consist of two-force members exclusively. Recall from [Subsection 3.3.3](#) that a two-force body is an object subjected to exactly two forces. Two-force members are not required to be slender or straight but can be recognized because they connect to other bodies or supports at exactly two points, and have no other loading unless it is also applied at those points.

Identifying two-force members is helpful when solving structures because they automatically establish the line of action of the two forces. For a two-force body to be in equilibrium, the forces acting on it must be equal in magnitude, opposite in direction, and act along a line passing through the points where the two forces are applied. Since these points are known, the direction of the line of action is readily found.

The common way to express the force of a two-force member is with a magnitude and a sense, where the sense is either tension or compression. If the two forces tend to stretch the object we say it is in *tension*; if they act the other way and squash the object, it is in *compression*. The usual approach is to assume that a two-force member is in tension, then draw the free-body diagram and write the equilibrium equations accordingly. If the analysis shows that the forces are negative then they actually act with the opposite sense, i.e. compression.



Figure 6.1.2 Two-force members in tension and compression.

6.2 Interactions between members

When analyzing structures we are dealing with multi-body systems and need to recall [Newton's 3rd Law](#), “For every action, there is an equal and opposite reaction.”

This law applies to multi-body systems wherever one body connects to another. At any interaction point, forces are transferred from one body to the interacting body as equal and opposite action-reaction pairs. These forces cancel out and are invisible when the structure is intact. Only when we cut through a member or joint in the isolation step of creating a free-body diagram, do we expose the interaction forces. When drawing free-body diagrams of the components of structures, it is critically important to represent these action-reaction pairs consistently. You may assume either direction for one, but the other *must* be equal and opposite.

For example, look at the members and joints in the truss below. Diagram (a) shows the truss members held together by pins at A , B , and C . The forces holding the parts together cancel and are not shown. In the ‘exploded’ view (b), the parts have been separated and the action-reaction pairs are exposed. Member AB is in tension, and the forces acting on it, also called AB , oppose each other and tend to stretch the member. These stretching forces are accompanied by equal and opposite forces, also called AB acting on pins A and B . Tensile forces BC and compressive forces CA behave similarly.

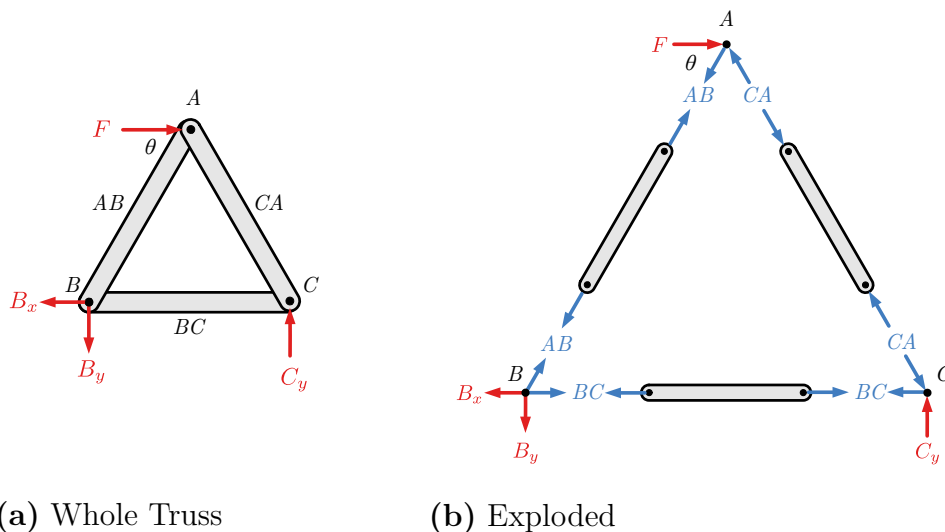
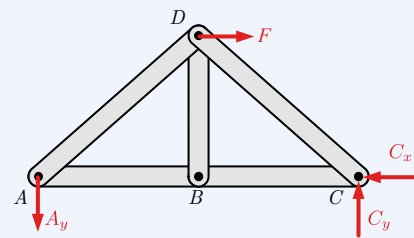

Figure 6.2.1 External load and global reactions in red. Internal action-reaction pairs in blue.

Thinking Deeper 6.2.2 Multi-body systems.

When a multipart structure is in equilibrium, each part of the structure is also in equilibrium. For example in the truss below, each member of the

truss, each joint, and each portion of the truss is also in equilibrium. This continues all the way down to the atoms of the structure. This universal equilibrium across spatial scales allows us to break multi-body systems into smaller solvable parts.



(a) Complete Truss

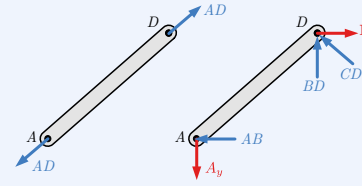

(b) Member AD

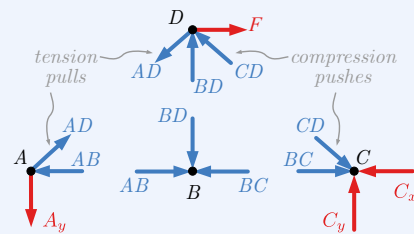

(c) Truss joints

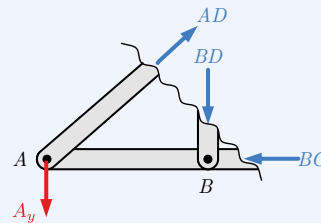

(d) Section

Figure 6.2.3 Possible free-body diagrams

You will see in this chapter that we have the freedom to isolate free-body diagrams at any scale to expose our target unknowns.

6.2.1 Load Paths

Load paths can help you think about structural systems. Load paths show how applied forces like the floor load in the image below pass through the interconnected members of the structure until they end up at the fixed support reactions. All structural systems, whether non-moving frames or moving machines have some sort of load path. When analyzing all structures, you computationally move from known values through the interconnected bodies of the system, following the load path, solving for unknowns as you go.

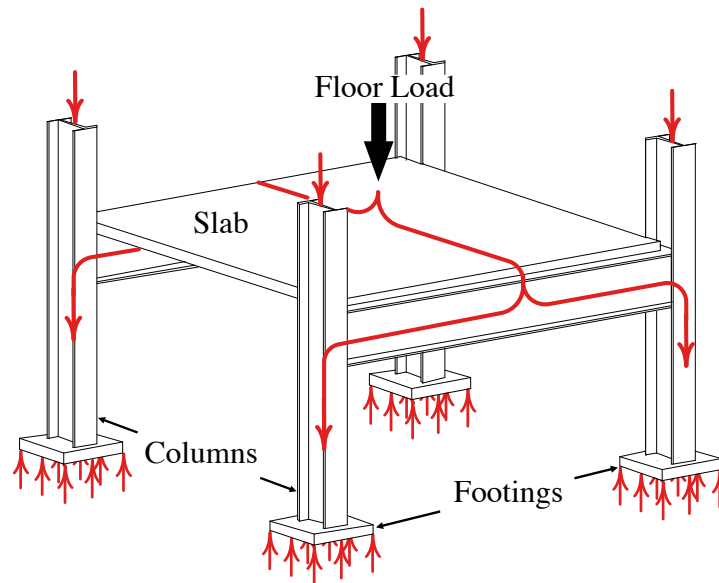

Figure 6.2.4 Load paths

6.3 Trusses

Key Questions

- What are simple trusses and how do they differ from other structural systems?
- What are the benefits and dangers of simple trusses?
- How can we determine the forces acting within simple truss systems?
- For a truss in equilibrium, why is every individual member, joint, and section cut from the truss also in equilibrium?
- How do we identify zero-force members in a truss and use their presence to simplify the analysis?

6.3.1 Introduction

A **truss** is a rigid engineering structure made up of long, slender members connected at their ends. Trusses are commonly used to span large distances with a strong, lightweight structure. Some familiar applications of trusses are bridges, roof structures, and pylons. **Planar trusses** are two-dimensional trusses built out of triangular subunits, while **space trusses** are three-dimensional, and the basic unit is a tetrahedron.

In this section, we will analyze a simplified approximation of a planar truss, called a **simple truss** and determine the forces the members individually support when the truss supports a load. Two different approaches will be presented: the **method of sections**, and the **method of joints**.

6.3.2 Simple Trusses

Truss members are connected to each other rigidly, by welding or joining the ends with a gusset plate. This makes the connecting joints rigid but also makes the truss difficult to analyze. To reduce the mathematical complexity in this text we will only consider **simple trusses**, which are a simplification appropriate for preliminary analysis.



Figure 6.3.1 Truss with riveted gusset plates.

Simple trusses are made of all two-force members and all joints are modeled as frictionless pins. All applied and reaction forces are applied only to these joints. Simple trusses, by their nature, are statically determinate, having a sufficient number of equations to solve for all unknown values. While the members of real-life trusses stretch and compress under load, we will continue to assume that all bodies we encounter are rigid.

Simple trusses are made of triangles, which makes them rigid when removed from supports. Simple trusses are determinate, having a balance of equations and unknowns, following the equation:

$$\underbrace{2 \times (\text{number of joints})}_{\text{system equations}} = \underbrace{(\text{number of reaction forces}) + (\text{number of members})}_{\text{system unknowns}}$$

Commonly, rigid trusses have only three reaction forces, resulting in the equation:

$$2 \times (\text{number of joints}) = 3 + (\text{number of members})$$

Unstable trusses lack the structural members to maintain their rigidity when removed from their supports. They can also be recognized using the equation above having more system equations on the left side of the equation above than system unknowns on the right.

Truss systems with redundant members have fewer system equations on the left side of the equation above than the system unknowns on the right. While they are indeterminate in statics, in later courses you will learn to solve these trusses too, by taking into account the deformations of the truss members.

Thinking Deeper 6.3.2 The Danger of Simple Trusses.

Simple trusses have no structural redundancy, which makes them easy to solve using the techniques of this chapter, however, this simplicity also has a dark side.



These trusses are sometimes called *fracture-critical trusses* because the failure of a single component can lead to catastrophic failure of the entire structure. With no redundancy, there is no alternative load path for the forces that normally would be supported by that member. You can visualize the fracture-critical nature of simple trusses by thinking about a triangle with pinned corners. If one side of a triangle fails, the other two sides lose their support and will collapse. In a full truss made of only triangles, the collapse of one triangle starts a chain reaction which causes others to collapse as well.

While fracture-critical bridges are being replaced by more robust designs, there are still thousands in service across the United States. To read more about two specific fracture critical collapses search the internet for the *Silver Bridge* collapse, or the *I-5 Skagit River Bridge* collapse.

6.3.3 Solving Trusses

“Solving” a truss means identifying and determining the unknown forces carried by the members of the truss when supporting the assumed load. Because trusses contain only two-force members, these internal forces are all purely axial. Internal forces in frames and machines will additionally include transverse forces and bending moments, as you will see in [Chapter 8](#).

Determining the internal forces is only the first step of a thorough analysis of a truss structure. Later steps would include refining the initial analysis by considering other load conditions, accounting for the weight of the members, relaxing the requirement that the members be connected with frictionless pins, and ultimately determining the stresses in the structural members and the dimensions required to prevent failure.

Two strategies to solve trusses will be covered in the following sections: the [Method of Joints](#) and the [Method of Sections](#). Either method may be used, but the Method of Joints is usually easier when finding the forces in all the members, while the Method of Sections is a more efficient way to solve for specific members without solving the entire truss. It’s also possible to mix and match methods.

The initial steps to solve a truss are the same for both methods. First, ensure that the structure can be modeled as a simple truss, then draw and label a sketch of the entire truss. Each joint should be labeled with a letter, and the members will be identified by their endpoints, so member AB is the member between joints A and B . This will help you keep everything organized and consistent in later analysis. Then, treat the entire truss as a rigid body and solve for the external reactions using the methods of [Chapter 5](#). If the truss is cantilevered and unsupported at one end you may not actually need the reaction forces and may skip this step. The reaction forces can be used later to check your work.

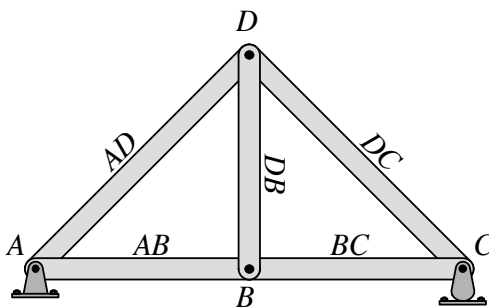

Figure 6.3.3 Truss Labels.

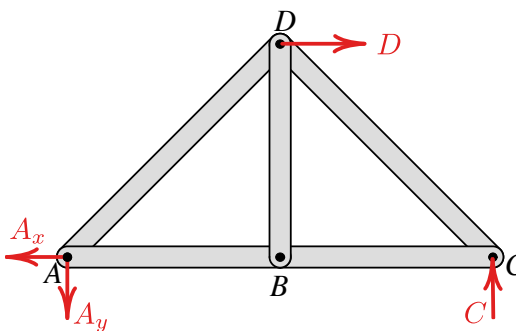

Figure 6.3.4 Free body diagram.

6.3.4 Zero-Force Members

Sometimes a truss will contain one or more zero-force members. As the name implies, zero-force members carry no force and thus support no load. Zero-force members will be found when you apply equilibrium equations to the joints, but

you can save some work if you can spot and eliminate them before you begin. Fortunately, zero-force members can easily be identified by inspection with two rules.

- Rule 1: If *two* non-collinear members meet at an unloaded joint, then both are zero-force members.
- Rule 2: If *three* forces (interaction, reaction, or applied forces) meet at a joint and two are collinear, then the third is a zero-force member.

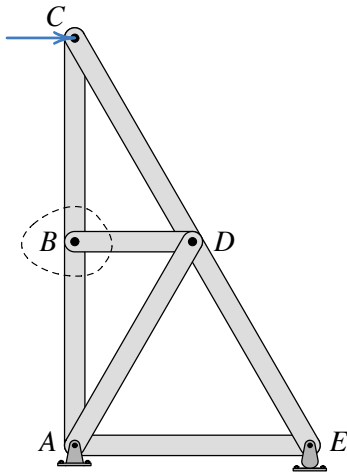

Consider the truss to the left. Assume that the dimensions, angles and the magnitude of force C are given. At joint B , there are two vertical collinear members as well as a third member which is horizontal, so Rule 2 should apply.

What does Rule 2 say about member BD ? Can it tell us anything about member DA ?

Cutting the members at the dotted boundary line exposes internal forces BC , BD and BA . These forces act along the axis of the corresponding members by the nature of two-force members, and for convenience have been assumed in tension although that may turn out to be incorrect.

Rule 2 applies here since BA and BC are collinear and BD is not.

The free-body diagram of joint B may be drawn by eliminating the cut members and only showing the forces themselves.

The situation is simple enough to apply the equilibrium equations in your head.

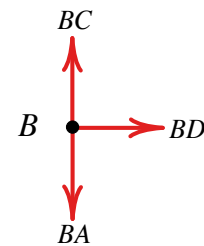
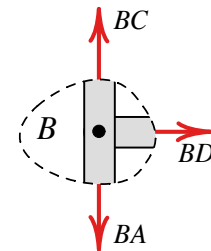

Vertically, forces BC and BA must be equal, and horizontally, force BD must be zero to satisfy $\Sigma F_x = 0$. We learn that member BD is a zero-force member.

While it is probably easiest to think about Rule 2 when the third member is perpendicular to the collinear pair, it doesn't have to be. Any perpendicular component must be zero which implies that the corresponding member is zero-force.

Finding zero-force members is an iterative process. If you determine that a member is zero-force, eliminate it and you may find others. Continuing the analysis at joint D draw its free-body diagram. Keep in mind that if one end of a member is zero-force the whole member is zero-force. Since member BD is zero-force, horizontal force BD acting on joint D is zero and need not be included on the free-body diagram, and the remaining three forces match the conditions to apply Rule 2.

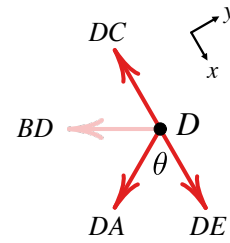

Analyzing the joint as before, but with a coordinate system aligned with the collinear pair,

$$\begin{aligned}\Sigma F_y &= 0 \\ DA \sin \theta &= 0\end{aligned}$$

This equation will be satisfied if $DA = 0$ or if $\sin \theta = 0$ but the second condition is only true when $\theta = 0^\circ$ or $\theta = 180^\circ$, which is not the case here. Therefore, force DA must be zero, and we can conclude that member DA is a zero-force member as well.

Finally consider joint C and draw its free-body diagram. Does either Rule apply to this joint? No. You will need to solve two equilibrium equations with this free-body diagram to find the magnitudes of forces CD and CB .

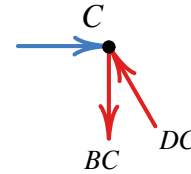

On the other hand, if the horizontal load C was not present or if either BC or DC was zero-force, then Rule 1 *would* apply and the remaining members would also be zero-force.

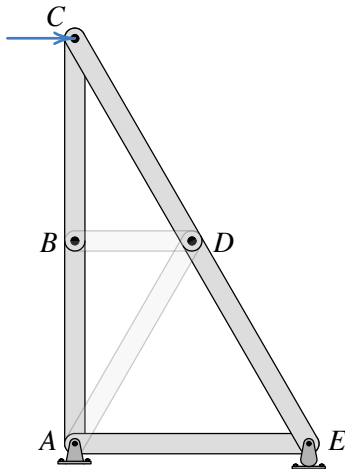

The final truss after eliminating the zero-force members is shown to the left. Forces $BC = BA$ and $DC = DE$ and the members may be replaced with longer members AC and CE .

The original truss has been reduced to a simpler triangular structure with only three internal forces to be found. Once you learn to spot zero force members, this simplification can be made without drawing any diagrams or performing any calculations.

Thinking Deeper 6.3.5 Why include Zero-Force Members?

You may be wondering what is the point of including a member in a truss if it supports no load. In our simplified example problems, they are unnecessary, but in the real world, zero-force members are important for several reasons:

- We have assumed that all members have negligible weight or if not, applied half the weight to each pin. The *actual* weight of *real* members invalidates the two-force body assumption and leads to errors. Consider a vertical member -- the internal forces must at least support the member's weight.
- Truss members are not actually rigid, and long slender members under compression will *buckle* and collapse. The so-called zero-force member will be engaged to prevent this buckling. In the previous example, members CD and DE are under compression and form an unstable equilibrium and would definitely buckle at pin D if they were not replaced with a single member CE with sufficient rigidity.
- Trusses are often used over a wide array of loading conditions. While a member may be zero-force for one loading condition, it will likely be engaged under a different condition — think about how the load on a bridge shifts as a heavy truck drives across.

So finding a zero-force member in a determinate truss does not mean you can discard the member. Zero-force members can be thought of as removed from the analysis, but only for the loading you are currently analyzing. After removing zero-force members, you are left with the simplest truss which connects the reaction and applied forces with triangles. If you misinterpret the rules you may over-eliminate members and be left with missing legs of triangles or 'floating' forces that have no load path to the foundation.

Example 6.3.6 Zero-Force Member Example.

Given the truss shown, eliminate all the zero-force members, and draw the remaining truss.

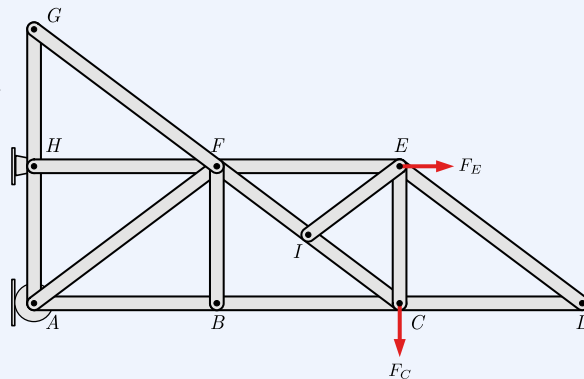

Solution. Rule 1:

- Due to two members meeting at unloaded joint G , both members GH and FG are zero-force members
- Due to two members meeting at unloaded joint D , both members DE and CD are zero-force members

Rule 2:

- Due to three forces meeting at joint B , with two being collinear (internal forces in AB and BC) then BF is a zero-force member.
- Due to three forces meeting at joint I , with two being collinear (internal forces in IF and CI), then EI is a zero-force member. Note that member EI does not need to be perpendicular to the collinear members to be a zero force.
- After removing zero-force members EI and DE , three forces remain at E , with two being collinear (internal force in EF and external load F_E), making EC a zero-force member.

The remaining truss is shown. Note that once EI and BF are eliminated, you can effectively eliminate the joints B and I as the member forces in the collinear members will be equal. Also notice that the truss is still formed of triangles which fully support all of the applied forces.

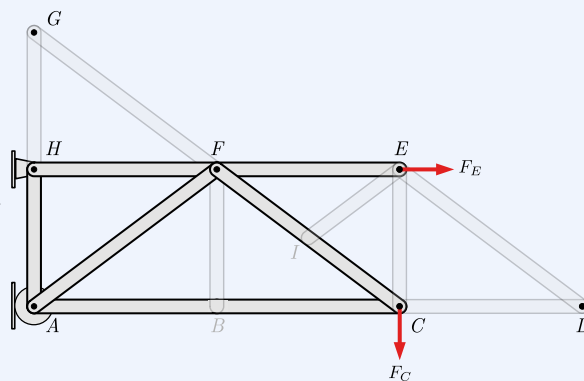

Try to find all the zero-force members in the truss in the interactive diagram

below, once you believe you have found all of them, check out the step-by-step solution in the interactive.

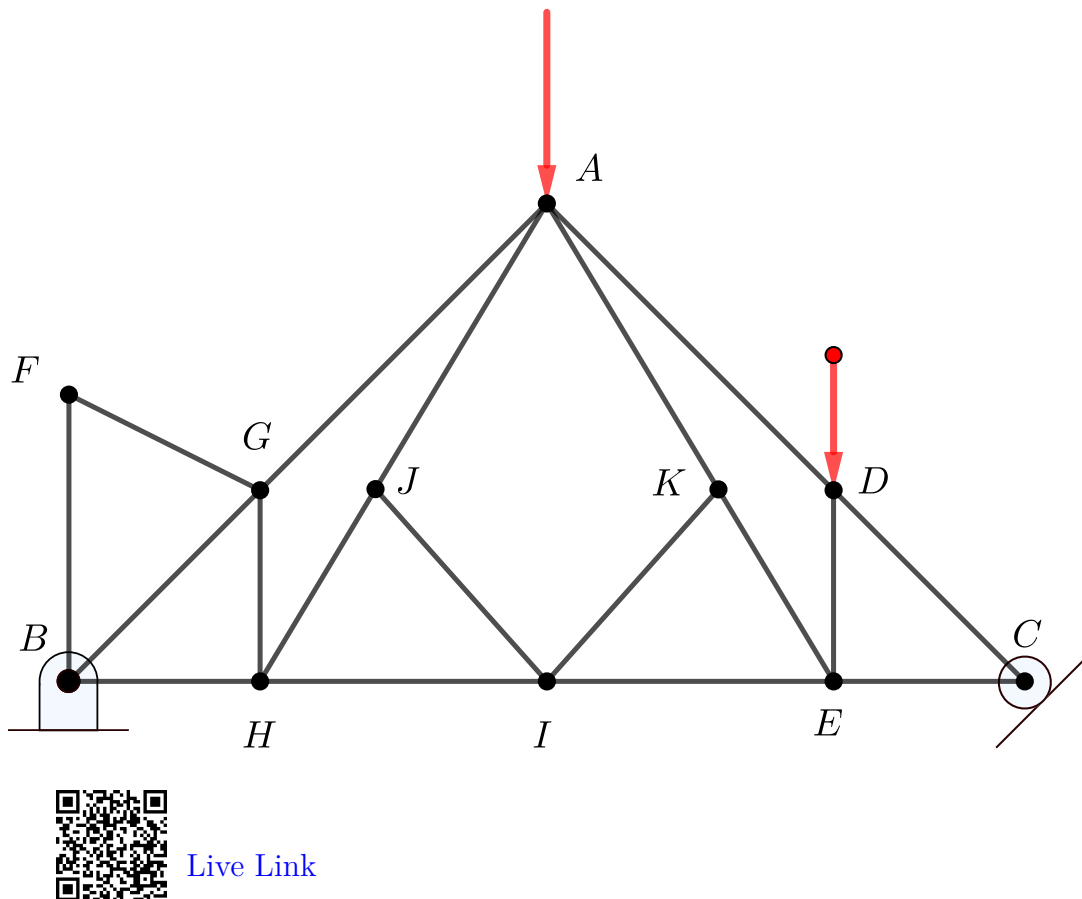

Figure 6.3.7 Identify zero-force members.

6.4 Method of Joints

Key Questions

- What are the important components to include on a free-body diagram of a joint in a truss?
- How are the solutions found at one joint used to create an accurate free-body diagram of another joint?
- How do we ensure that tension or compression in a member is properly represented?

The **method of joints** is a process used to solve for the unknown forces

acting on members of a truss. The method centers on the joints or connection points between the members, and it is most useful when you need to solve for all the unknown forces in a truss structure.

The joints are treated as particles subjected to force by the connected members and any applied loads. As the joints are in equilibrium and the forces are concurrent, $\Sigma \mathbf{F} = 0$ can be applied, but the $\Sigma M = 0$ equation provides no information.

For planar trusses, each joint yields two scalar equations, $\Sigma F_x = 0$ and $\Sigma F_y = 0$, and so two unknowns can be found. Therefore, a joint can be solved when there are one or two unknown forces and at least one known force acting on it.

Forces are transferred from joint to joint by the connecting members, so when unknown forces on a joint are found, the corresponding forces on adjacent joints are also found.

6.4.1 Procedure

The procedure is a straightforward application of rigid body and particle equilibrium

1. Determine if the structure is a truss and if it is determinate. See [Subsection 6.3.2](#)
2. Identify and remove all zero-force members. This is not required but will eliminate unnecessary computations. See [Subsection 6.3.4](#).
3. Determine if you need to find the external reactions. If you can identify a solvable joint immediately, then you do not need to find the external reactions.

A solvable joint includes one or more known forces and no more than two unknown forces. If there are no joints that satisfy this condition then you will need to find the external reactions before proceeding, using a free-body diagram of the entire truss.

4. Identify a solvable joint and solve it using the methods of [Chapter 3](#). When drawing free-body diagrams of joints you should
 - Represent the joint as a dot.
 - Draw all known forces in their known directions with arrowheads indicating their sense. Known forces are the given loads and forces determined from previously solved joints.
 - Assume the sense of unknown forces. A common practice is to assume that all unknown forces are in tension, i.e. pulling away from the free-body diagram of the pin, and label them based on the member they represent.

Finally, write out and solve the force equilibrium equations for the joint. If you assumed that all forces were tensile earlier, negative answers indicate compression.

5. Once the unknown forces acting on a joint are determined, carry these values to the adjacent joints and repeat step four until all the joints have been solved. Take care when transferring forces to adjoining joints to maintain their sense — either tension or compression.
6. If you solved for the reactions in step two, you will have more equations available than unknown forces when you reach the last joint. The extra equations can be used to check your work.

Rather than solving the joints sequentially, you could write out the equations for all the joints first and solve them simultaneously using a matrix solution, but only if you have a computer available as large matrices are not typically solvable with a calculator.

The interactive below shows a triangular truss supported by a pin at A and a roller at B , and loaded at joint C . You can see how the reactions and internal forces adjust as you vary the load at C . You can solve it by starting at joint C and solving for BC and CD , then moving to joint B and solving for AB . Joint A can be used to check your work.

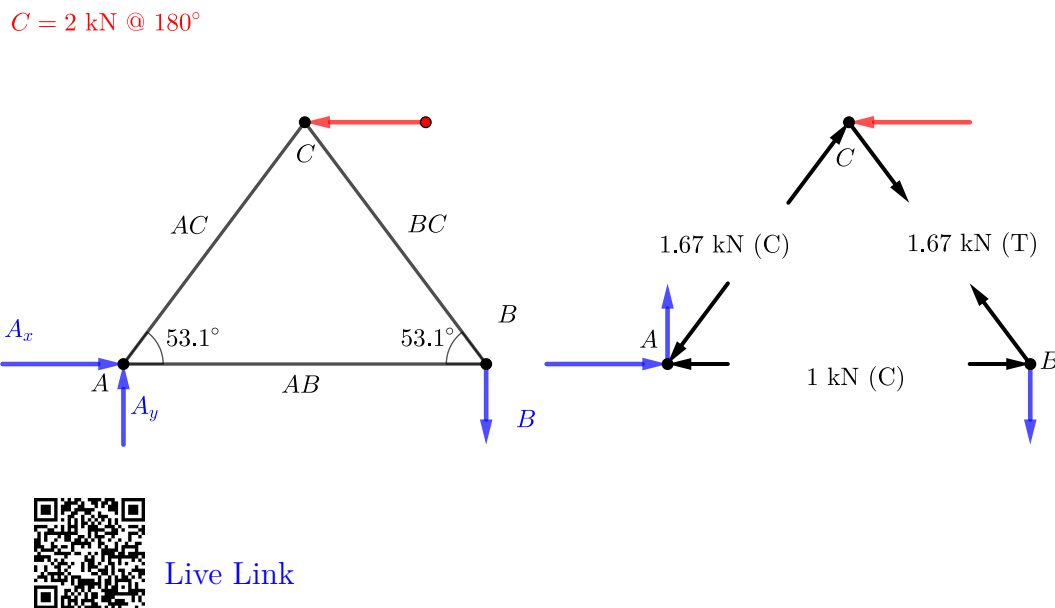

Figure 6.4.1 Internal and external forces of a simple truss.

6.5 Method of Sections

Key Questions

- How do we determine an appropriate section to cut through a truss?
- How are equilibrium equations applied to a section?

The **method of sections** is used to solve for the unknown forces within specific members of a truss without solving for them all. The method involves dividing the truss into sections by cutting through the selected members and analyzing the section as a rigid body. The advantage of the Method of Sections is that the only internal member forces exposed are those which you have cut through, the remaining internal forces are not exposed and thus ignored.

6.5.1 Procedure

The procedure to solve for unknown forces using the method of sections is

1. Determine if a truss can be modeled as a [simple truss](#).
2. Identify and eliminate all [zero-force members](#). Removing zero-force members is not required but may eliminate unnecessary computations.
3. Solve for the external reactions, if necessary. Reactions will be necessary if the reaction forces act on the section of the truss you choose to solve below.
4. Use your imaginary chain saw to cut the truss into two pieces by cutting through some or all of the members you are interested in. The cut does not need to be a straight line.

Every cut member exposes an unknown internal force, so if you cut three members you'll expose three unknowns. Exposing more than three members is not advised because you create more unknowns than available equilibrium equations.

5. Select the easier of the two halves of the truss and draw its free-body diagram.
 - Include all applied and reaction forces acting on the section, and show known forces acting in their known directions.
 - Draw unknown forces in assumed directions and label them. A common practice is to assume that all unknown forces are in tension and label them based on the endpoints of the member they represent.

6. Write out and solve the equilibrium equations for your chosen section. If you assumed that unknown forces were tensile, negative answers indicate compression.
7. If you have not found all the required forces with one section cut, repeat the process using another imaginary cut or proceed with the method of joints if it is more convenient.

The interactive below demonstrates the method of sections. The internal forces in the truss members are exposed by cutting through the truss at three locations. The known loads are shown in red, and the unknown reactions F_x , A_x and A_y , and unknown member forces are shown in blue. All members are assumed to be in tension. In this situation, it is not necessary to find the reactions if the section to the right of the cut is selected.

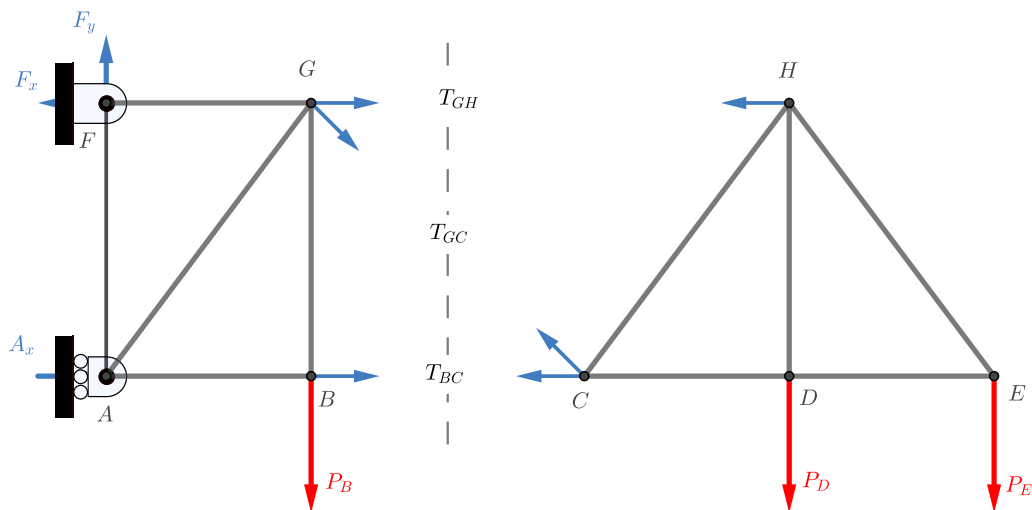

[Live Link](#)

Figure 6.5.1 Method of sections demonstration.

6.6 Frames and Machines

Key Questions

- How are frames and machines different from trusses?
- Why are the methods of joints and sections not appropriate for frames and machines?
- How do we identify if a structure is independently rigid?

- How do we apply equilibrium equations to each member of the structure, and ensure that the sense of a force appearing on multiple free-body diagrams is consistent?

Frame and machines are engineering structures that contain at least one multi-force member. As their name implies, multi-force members have more than two concentrated loads, distributed loads, and/or couples applied to them and therefore are not two-force members. Note that all bodies we investigated in [Chapter 5](#) were all multi-force bodies.

Frames are rigid, stationary structures designed to support loads and must include at least one multi-force member.

Machines are non-rigid structures where the parts can move relative to one another. Generally, they have an input and an output force and are designed to produce a mechanical advantage. Note that all machines in this text are in static equilibrium by their interacting and applied forces.

Though there is a design difference between frames and machines they are grouped together because they can both be analyzed using the same process, which is the subject of this section.



Figure 6.6.1 Frames are rigid objects containing multi-force members.



Figure 6.6.2 Machines contain multi-force members that can move relative to one another.

6.6.1 Analyzing Frames and Machines

Analyzing a frame or machine means determining all applied, reaction, and internal forces and couples acting on the structure and all of its parts.

Multi-part structures are analyzed by mentally taking them apart and analyzing the entire structure and each part separately. Each component is analyzed as a separate rigid body using the techniques we have already seen.

Although we can separate the structure into parts, the parts are not independent since, by Newton's Third Law, every interaction is half of a complementary pair. For every force or moment of body A on B there is an equal-and-opposite force or moment of body B on body A and the free-body diagrams must reflect

this. Incorrect representation of these interacting pairs on free-body diagrams is a common source of student errors.

Once the frame or machine is disassembled and free-body diagrams have been drawn, the structure is analyzed by applying equations of equilibrium to free-body diagrams, exactly as you have done before —there’s nothing new here.

The difficulty arises first in selecting objects and drawing correct free-body diagrams and second, in identifying an efficient solution strategy since you usually won’t be able to completely solve a diagram without first finding the value of an unknown force from another diagram.

In [Chapter 5](#) we saw that each two-dimensional free-body diagram results in up to three linearly independent equations. By disassembling the structure we create new free-body diagrams that can be used to determine more unknown values. Here are a few more details on the number of equations that come from each type of two-dimensional free-body diagram:

- *Two-force members.*

One equation. Two-force members can be recognized as either a cable or a weightless link with all forces coming from two frictionless pins. The force at one pin is equal and opposite to the force on the other placing the body in tension or compression.

- *Objects with concurrent forces and no couple-moments.*

Two equations. These are the problems you solved in [Chapter 3](#). There are two equations available $\Sigma F_x = 0$ and $\Sigma F_y = 0$.

- *Multi-force rigid body with non-concurrent forces and/or couples.*

Three equations. These are the most general body types. Use $\Sigma F_x = 0$, $\Sigma F_y = 0$, and $\Sigma M = 0$ to solve for three unknowns.

Procedure

The process used to analyze frames and machines is outlined below

1. Determine if the entire structure is independently rigid. An independently rigid structure will hold its shape even when separated from its supports. Look for triangles formed among the members, as triangles are inherently rigid. If it is not independently rigid, the structure will collapse when the supports are removed.

If the structure is not independently rigid, skip to the next step. Otherwise, model it as a single rigid body and determine the external reaction forces.

2. Draw a free-body diagram for each of the members in the structure. You must represent all forces acting on each member, including:

- Applied forces and couples and the weights of the components if non-negligible.
- Interaction forces due to two-force members. There will be a force of unknown magnitude but the known direction at points connected to two-force members. The forces will act along the line between the two connection points.
- All reaction forces and moments at the connection points between members. Forces with an unknown magnitude and direction are usually represented by unknown x and y components, but can also be represented as a force of unknown magnitude acting in an unknown direction.

All interaction forces and moments between connected bodies *must* be shown as equal-and-opposite action-reaction pairs.

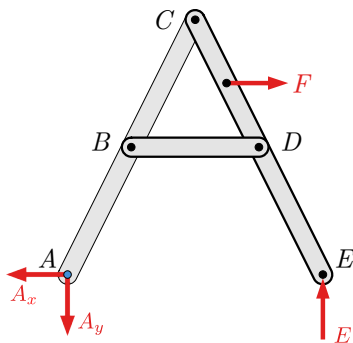

Figure 6.6.3 Free-body diagram of a rigid frame with pin at A , roller at E , and load at F .

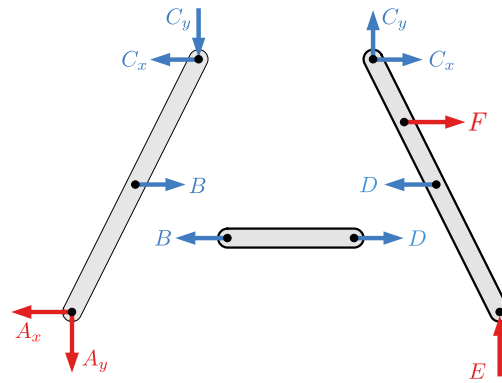

Figure 6.6.4 Free body diagrams of the individual components. External forces are in red, and exposed action-reaction pairs are in blue.

3. Write out the equilibrium equations for each free-body diagram.
4. Solve the equilibrium equations for the unknowns. You can do this algebraically, solving for one variable at a time, or you can use matrix equations to solve for everything at once. Negative magnitudes indicate that the assumed direction of that term was incorrect, and the actual force/moment is opposite the assumed direction.

In the following example, we'll discuss how to select objects, distinguish external and internal loads, draw consistent and correct free-body diagrams, and identify a good solution strategy.

Free-body diagram of structures

Drawing free-body diagrams of complex frames and machines can be tricky. In this section, we will walk through the process of selecting appropriate objects

and drawing consistent and correct free-body diagrams to solve a typical machine problem.

The toggle clamp shown in Figure 6.6.5 is used to quickly secure wooden furniture parts to the bedplate of a CNC router in order to cut mortise and tenon joints. The component parts are shown and named in Figure 6.6.6.

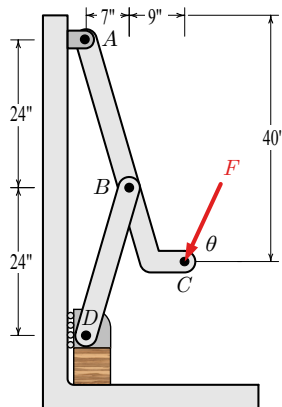

Figure 6.6.5 Original diagram

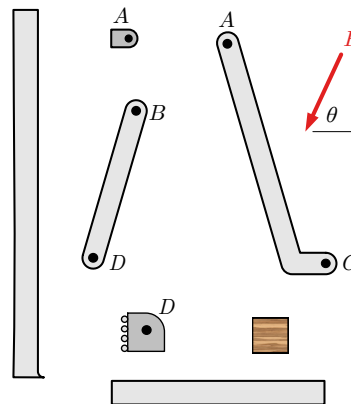

Figure 6.6.6 Component parts.

This original diagram is not a free-body diagram because all the forces necessary to hold the objects in equilibrium are not indicated. The only force shown is F , which is supplied by some external agent, presumably the machine operator. We must assume that the wall and floor are still attached to the world and held fixed.

To perform an equilibrium analysis, we need to develop one or more free-body diagrams and apply the equations of equilibrium to them. Free-body diagrams can be drawn for the entire structure, each individual part, and any combination of connected parts. Not all these diagrams will be needed, and part of the challenge of solving these problems is selecting and drawing only the diagrams you need. In any event, a clear decision must always be made about what is part of the free body and what is not.

When we separate one body from another loads will appear on both bodies which act to constrain them as they were constrained before the separation. These forces and moments must be represented on the free-body diagrams consistently as halves of equal-and-opposite action-reaction pairs.

For this discussion, we will progressively exclude parts from the original structure and draw the free-body diagram of what remains. In so doing we will clarify the difference between internal and external forces, recognize and take advantage of two-force bodies, and provide some tips for drawing correct free-body diagrams. In an actual situation, you will not need to draw all these diagrams, instead, you should think through the situation and draw only the diagrams you will need for a solution.

It is helpful to consider which loads are known and which are unknown as you prepare free-body diagrams. In planar problems, a free-body diagram with three

or fewer unknowns may be solved immediately. When there are more than three unknowns, you must incorporate information from other diagrams to complete the solution.

Exclude the floor. To begin, we can remove the floor from the system. Everything except the floor is now included as our body; only the floor is excluded. The floor was in contact with the wooden block and connected to the wall.

Since we don't know how the wall and the floor are connected we will assume a rigid, fixed connection. We also have to model how the wall is attached to the rest of the world. The fixed support from wall-to-world and wall-to-floor can be combined to be a single set of three loads which we represent as horizontal and vertical forces V_x and V_y , and a concentrated moment M_v .

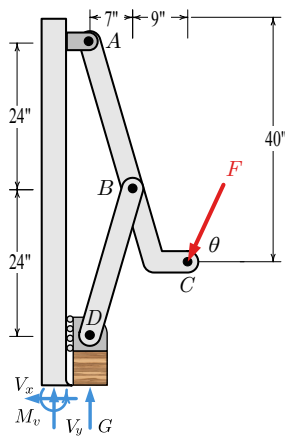

Included	Excluded
Lever ABC , Short Link BD , Wooden Block, Roller D , Wall, Bearing A	Floor

Figure 6.6.7 Free-body Diagram 1

The effect of the floor on the block is represented by a single vertical force G which holds the block the same way the floor was previously supporting it; the loads you add must constrain your object the same way they were constrained in the real world. This representation is a simplification of the actual situation since the force of the floor is distributed over the bottom surface of the block; however, this simplification is justified in much the same way as we represent the weight of an object as a single force acting at its center of gravity.

Tips.

- Include friction if it's given or obvious.
- Internal forces in rigid bodies should be modeled as a fixed support.
- If you need info that you don't have, select a variable to act as its name.

Exclude the wall. If you next remove the wall, forces G and F remain from before, but we now expose four loads from where the wall was connected to what

is now our body; a normal force N at the roller and three loads from the fixed support between the bearing block and the wall W_x , W_y , and M .

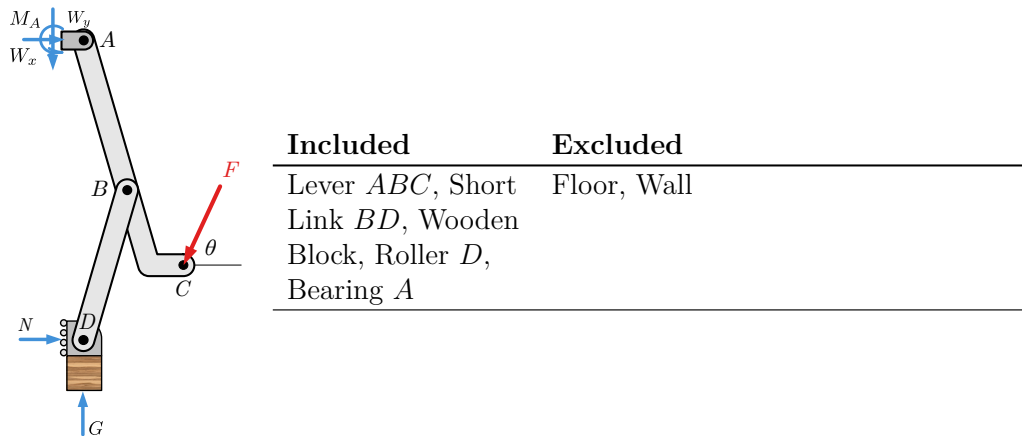

Figure 6.6.8 Free-body diagram 2

Note that the reactions between the wall and the floor are no longer included in the free-body diagram because they are both on the same side of the included-excluded table. Only loads that cross from included to excluded produce a load on the free-body diagram.

Tips.

- Every force needs a point of application and a clear arrowhead.
- Indicate any distances and angles needed and not available on the original diagram.
- Define the direction of forces that are not vertical or horizontal with an angle from a reference direction.
- Define a coordinate system unless you are using the standard x - y axes.
- Do not add forces that don't act on your body.

Exclude the bearing at A . We are not interested in the loads between the bearing block and the wall W_x , W_y , and M and further, the free-body diagram still includes too many unknowns to solve.

After removing the bearing we reduce the unknowns at A to two because the bearing block and the lever are connected with a pin while the bearing block and wall were connected with a fixed support. The loads W_x , W_y , and M and V_x , V_y , and M_v are not included on this free-body diagram because they don't act on this object.

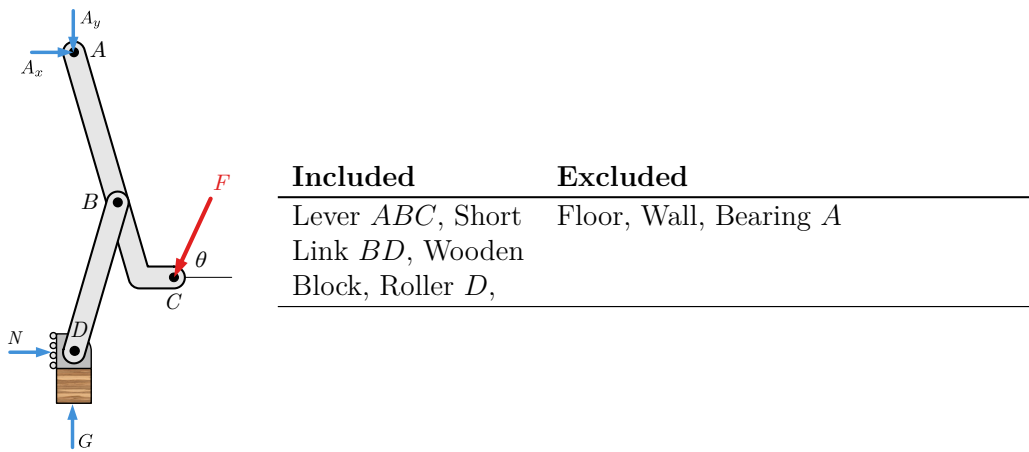

Figure 6.6.9 Free-body diagram 3

The load from the short link at B does not appear on this free-body diagram because it is internal. Internal loads connect two parts of the body together. They should not be included in the free-body diagram because they always occur in equal and opposite pairs which cancel each other out.

Tips.

- Look for free-body diagrams that include only three unknowns in two dimensions or six unknowns in three.
- Don't include internal loads on your free-body diagrams.



A free-body diagram of the block shows the clamp force Q , which we are seeking.

Note that $Q \neq G$. These forces are given different names since they may have different magnitudes. If the weight of the block is small¹ in comparison to the other forces acting on the object it may be neglected, in which case $Q = G$ and they can be given the same name.

Examine the wooden block. **Figure 6.6.10** Free-body diagram 4 (block)

Tips.

- If the two forces are not the same don't identify them by the same name.
- Make as few assumptions as you possibly can. Make a note of any assumptions you make.
- In textbook problems, if the weight of an object is not mentioned it

¹(less than about 0.1%)

may be neglected.

Exclude the wooden block. We can further simplify the diagram by removing the wooden block, leaving only the roller, short link and lever.

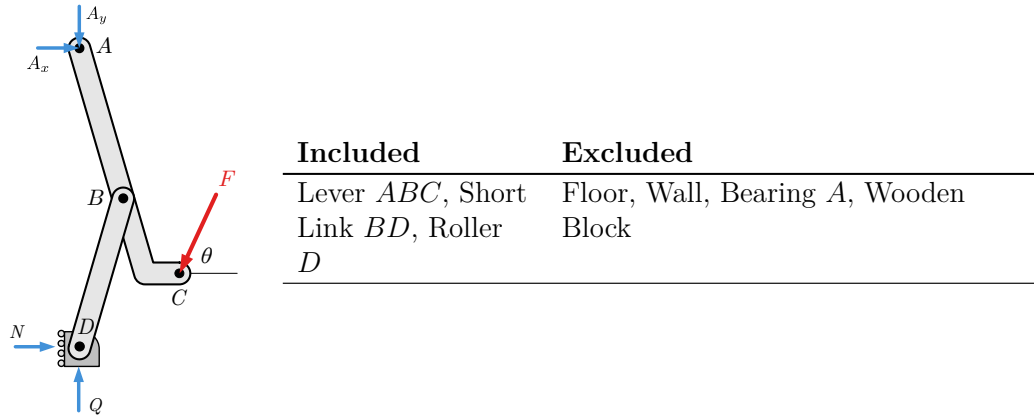
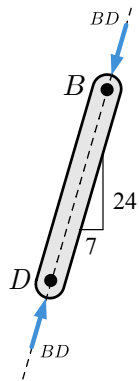

Figure 6.6.11 Free-body diagram 5 (lever and link)

Examine the short link BD . The short link BD is a two-force body and as discussed in [Subsection 3.3.3](#) can only be in equilibrium if the forces at B and D are equal-and-opposite and act along a line passing through these two points. This means that the 24:7 slope of the link determines the direction of force BD .



When drawing free-body diagrams, forces with known directions should be drawn pointing in that direction rather than breaking them into components, otherwise, you may lose track of the fact that the x and y components are not independent but are actually related by the direction of the force.

Figure 6.6.12 Free-body diagram 6 (short link)

Here we have assumed that the forces acting on the link are compressive. If the equilibrium equations produce a positive value for BD our assumption is proved correct, while a negative result indicates that we were wrong and the link is actually in tension.

Tips.

- A short-link is a two-force body.

- Recognize two-force bodies because they give you information about direction.
- Represent the force of a two-force body as a force with unknown magnitude acting along a known line of action, not as x and y components.
- If you don't know the sense of a force along its line of action, assume one. If you guess wrong, the analysis will give you a negative value.

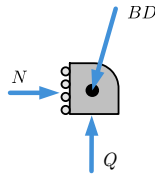

Note that the force BD acting on the roller is shown pointing down and to the left. This is equal and opposite to the force DB acting on the link at D , which points up and to the right. These two must act in opposite directions because they are an action-reaction pair.

Examine the roller at D . Figure 6.6.13 Free-body diagram 7 (roller)

The roller is a three-force body, so the lines of action of N , Q , and BD are coincident and it may be treated as a particle. Equilibrium analysis shows that N and Q must oppose the horizontal and vertical components of force BD .

The clamping force Q produced by the toggle clamp appears on this free-body diagram so it will be important later for the solution.

Tips.

- Recognize three-force bodies and use their special properties to your advantage.
- Use the same name for the exposed forces on interacting bodies since they are equal-and-opposite halves of an action-reaction pair.

Exclude the roller. We can further simplify the free-body diagram by removing the roller. The roller and short link are connected with a pin but, for equilibrium, the forces acting on a short link (or any two-force body) must share the same line of action — the line connecting its endpoints; otherwise, components perpendicular to this line would produce an unbalanced moment about the other endpoint.

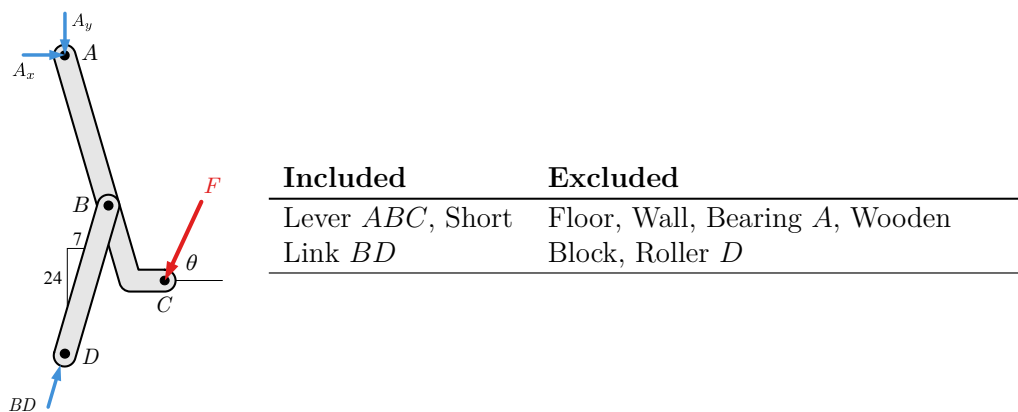

Figure 6.6.14 Free-body diagram 8

Exclude the short link. The previous free-body diagram has three unknowns and can be solved but the free-body diagram of the lever by itself is also correct, and this is the free-body diagram that most people begin with.

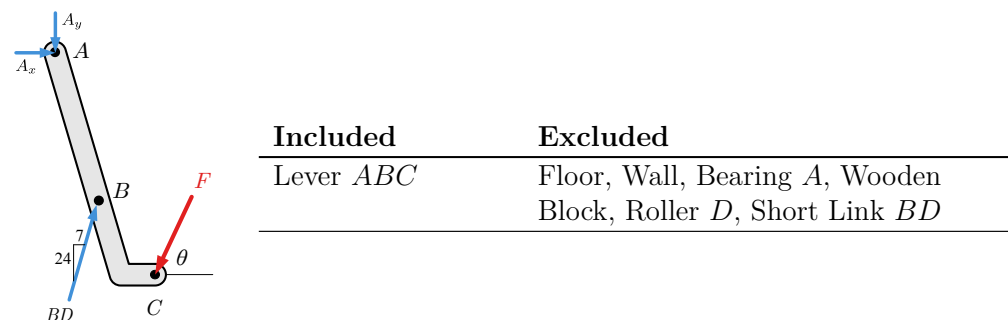

Figure 6.6.15 Free-body diagram 9 (lever)

The load BD acting on the lever in this diagram has the same magnitude, direction, and line of action as the load acting on the short link at D , so this can be thought of as sliding a force along its line of action — an equivalent transformation.

The following loads are not shown here because they act between two objects that are not part of the body:

- the loads between the bearing block and the wall W_x , W_y , and M ,
- the loads between the floor and the wall V_x , V_y , and M_v ,
- the load between the block and the floor G , and
- the load between the roller and the wall N .

All of the free-body diagrams we have drawn are correct, though not all are necessary. Generally, we only draw the free-body diagrams needed for the solution. These diagrams form a chain that connects the known input forces to the desired output forces. When solving frames and machines, think carefully

about what you know and what you need to solve for: that determines which free-body diagrams you will need. Taking a few moments to consider what unknowns you'd have at each step can help you optimize your problem-solving effort.

You should recognize that it is possible to draw incorrect free-body diagrams which produce correct results. Consider the diagram below.

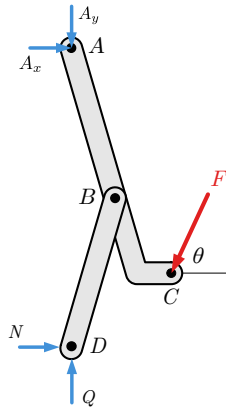

This diagram doesn't accurately represent what is happening at pin D .

Figure 6.6.16 Free-body diagram 10 (Subtly incorrect)

Forces N and Q do not actually act on the short link at D . Force N acts between the roller and the wall and clearly this diagram doesn't include the roller. Similarly Q acts between the block and the roller. These forces don't belong on the free-body diagram even though they are equal to the x and y components of force BD . Only forces that cross the imaginary boundary between the object and the rest of the world belong on the free-body diagram.

Students are inclined to argue that this free-body diagram is statically equivalent to [Figure 6.6.11](#) and it produces the correct answer so it must be OK. It isn't correct because it reflects a misunderstanding about what you are modeling and what you aren't. Other engineers using your FBDs need to know what you are modeling. The FBD is the key to your analysis of the real world.

Example 6.6.17 Toggle Clamp.

Knowing that angle $\theta = 60^\circ$, find the vertical clamping force acting on the piece at D and the magnitude of the force exerted on member ABC at pin B in terms of force F applied to the clamp arm at C .

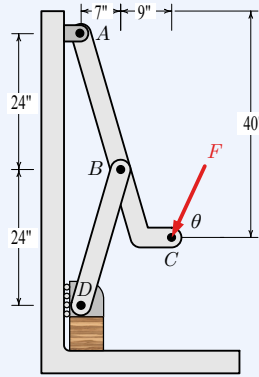

Solution. For this problem, we need two free-body diagrams. The first links the input force F to the link force BD , and the second links BD to the clamping force Q .

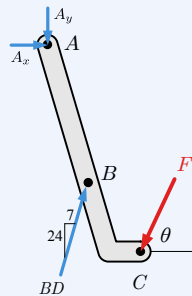

(a) FBD I

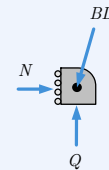

(b) FBD II

Figure 6.6.18

We will assume the two-force member BD is in compression based on the physical situation. The forces acting on the link, lever and roller are all directed along a line of action defined by a 7-24-25 triangle. Similar triangles give

$$BD_x = \left(\frac{7}{25}\right) BD$$

$$BD_y = \left(\frac{24}{25}\right) BD$$

Applying $\sum M = 0$ at A to the free-body diagram of the lever gives BD in terms of F .

$$\text{FBD I: } \sum M_A = 0$$

$$BD_x(24) + BD_y(7) - F_x(40) - F_y(16) = 0$$

$$\left(\frac{7}{25}BD\right)(24) + \left(\frac{24}{25}BD\right)(7) = (F \cos 60^\circ)(40) + (F \sin 60^\circ)(16)$$

$$13.44BD = 33.86F$$

$$BD = 2.52F$$

The positive sign on the answer reveals that our assumption that member BD was in compression was correct.

Applying $\sum F_y = 0$ to the free-body diagram of the roller will give Q in terms of F .

$$\text{FBD II: } \Sigma F_y = 0$$

$$Q - BD_y = 0$$

$$\begin{aligned} Q &= \frac{24}{25}BD \\ &= \frac{24}{25}(2.52F) \\ &= 2.42F \end{aligned}$$

While you could certainly find A_x , A_y and N using other equilibrium equations they weren't asked for and we don't bother to find them.

Thinking Deeper 6.6.19 Why does the Method of Joints work on trusses but not on Frames or Machines?

We can solve trusses using the methods of joints and method of sections because all members of a simple truss are two-force bodies. Cutting a truss member exposes an internal force that has an unknown scalar magnitude, but a known line of action. The force acts along the axis of the member and causes no bending if the member is straight. Cutting a truss member exposes *one* unknown.

Frames and machines are made of multi-force members and cutting these, in general, exposes:

- A force with an unknown magnitude acting in an unknown direction, and
- A bending moment at the plane of the cut.

Cutting a two-dimensional multi-force member exposes *three* unknowns, and *six* are exposed for a three-dimensional body. The number of unknowns quickly exceeds the available equations rendering the problem impossible to solve.

Bottom line: use the method of sections and joints *only* for trusses made of two-force straight members; for all other multi-force rigid body systems draw and analyze free-body diagrams of the components.

6.7 Summary

The various equilibrium topics we have covered and the associated problem-solving techniques are summarized below.

You should be able to recognize these situations, draw the associated free-body diagrams and solve for the unknowns of each case.

Particle Equilibrium. An object may be treated as a particle when the forces acting on it are coincident, that is, all of their lines of action intersect at a common point. In this case, they produce no moment to rotate the object, and $\Sigma \mathbf{M} = 0$ is not helpful. The applicable equation is

$$\Sigma \mathbf{F} = 0,$$

which produces two scalar equations in two dimensions and three scalar equations in three dimensions.

Rigid Body Equilibrium. A rigid body can rotate and translate so both force and moment equilibrium must be considered.

$$\begin{aligned}\Sigma \mathbf{F} &= 0 \\ \Sigma \mathbf{M} &= 0\end{aligned}$$

In two dimensions, these equations produce two scalar force equations and one scalar moment equation. Up to three unknowns can be determined.

In three dimension, they produce three scalar force equations and three scalar moment equations. Up to six unknowns can be determined.

Trusses. A truss is a structure that consists entirely of two-force members and only carries forces at the joints connecting members. Two-force members and loading at joints allow free-body diagrams of the joints to expose the axial loads in members.

In addition to the equations provided by treating the entire truss as a rigid body, each joint provides two additional equations for two-dimensional trusses, and three for non-planar trusses.

Frames and Machines. Frames and machines are structures that contain multiple rigid body systems. Frames don't move and are designed to support loads. Machines are generally designed to multiply forces and usually have moving parts. Both frames and machines can be solved using the same methods.

All interactions between bodies are equal and opposite action-reaction pairs. When solving frames and machines

- Two-force members provide one useful equilibrium equation and can determine one unknown.

- In two dimensions, rigid bodies result in two scalar force equations and one scalar moment equation. Up to three unknowns can be determined.
- In three dimensions, rigid bodies produce three scalar force equations and scalar three moment equations. Up to six unknowns can be determined.

6.8 Exercises (Ch. 6)

Chapter 6 Exercises

Truss: Method of Joints	0/165
Solve a joint	0/30 Not attempted
Cantilever truss	0/30 Not attempted
Zero force members	0/20 Not attempted
Kingpost truss	0/45 Not attempted
Symmetric Truss	0/40 Not attempted
Truss: Method of Sections	0/83
Cantilever truss	0/15 Not attempted
Howe Truss	0/28 Not attempted
Pratt Truss	0/30 Not attempted
Maximum load	0/10 Not attempted
Frames	0/140
Crossback frame	0/30 Not attempted
Frame: A-Frame with load	0/30 Not attempted
Frame: A-frame Difficulty 1	0/20 Not attempted
Frame: A-frame Difficulty 2	0/20 Not attempted
Frame: A-frame Difficulty 3	0/20 Not attempted
Frame: A-frame Difficulty 4	0/20 Not attempted
Machines	0/107
Machine: Pliers	0/20 Not attempted
Machine: Vice Grips	0/20 Not attempted
Machine: Pruning Shears	0/25 Not attempted
Machine: Excavator	0/22 Not attempted
Machine: Lopping Shears	0/20 Not attempted

Display options

Done



Standalone
In Context

Chapter 7

Centroids and Centers of Gravity

A **centroid** is the geometric center of a geometric object: a one-dimensional curve, a two-dimensional area or a three-dimensional volume. Centroids are useful for many situations in Statics and subsequent courses, including the analysis of distributed forces, beam bending, and shaft torsion.

Two related concepts are the **center of gravity**, which is the average location of an object's *weight*, and the **center of mass** which is the average location of an object's *mass*. In many engineering situations, the centroid, center of mass, and center of gravity are all coincident. Because of this, these three terms are often used interchangeably without regard to their precise meanings.

We consciously and subconsciously use centroids for many things in life and engineering, including:

Keeping your body's balance: Try standing up with your feet together and leaning your head and hips in front of your feet. You have just moved your body's center of gravity out of line with the support of your feet.

Computing the stability of objects in motion like cars, airplanes, and boats: By understanding how the center of gravity interacts with the accelerations caused by motion, we can compute safe speeds for sharp curves on a highway.

Designing the structural support to balance the structure's own weight and applied loadings on buildings, bridges, and dams: We design most large infrastructure not to move. To keep it from moving, we must understand how the structure's weight, people, vehicles, wind, earth pressure, and water pressure balance with the structural supports.

You probably have already developed a good intuition about centroids and centers of gravity based upon your life experience, and can roughly estimate their location when you look at an object or diagram. In this chapter you will learn to locate them precisely using two techniques: [integration 7.7](#) and the method of [composite parts 7.5](#).

7.1 Weighted Averages

You certainly know how to find the average of several numbers by adding them up and dividing by the number of values, so for example the average of the first four positive integers is

$$\frac{1 + 2 + 3 + 4}{4} = 2.5$$

More formally, if a is a set with n elements then the average, or **mean**, value is

$$\bar{a} = \frac{1}{n} \sum_{i=1}^n a_i = \frac{a_1 + a_2 + \cdots + a_n}{n}. \quad (7.1.1)$$

This average is also called the **arithmetic mean**. When calculating an arithmetic mean, each number is equally important when evaluating the average. The overbar symbol is often used to indicate that a quantity is a mean value.

In situations where some values are more important than others, we use a **weighted average**. A familiar example is your grade point average. Your GPA is calculated by weighting your grade for each class by the credits for that class, then dividing by the total credits you have taken. The credit values are called the **weighting factors**.

In general terms a weighted average is

$$\bar{a} = \frac{\sum a_i w_i}{\sum w_i} \quad (7.1.2)$$

Where a_i are the values we are averaging and w_i are the corresponding weighting factors. The weighting factors may be different for each item being averaged, so w_i is the weighting factor for value a_i . In this book we will not write the limits on the sums, and understand that the intent is always to sum over all the values. Notice that if the weighting factors are all identical, they can be factored out of the sums so the weighted average and the arithmetic mean will be the same.

Weighted averaging is used to find centroids, centers of gravity and centers of mass, the subject of this chapter. All three are *points* located at the “center” the object, but the meaning of “center” depends on the weighting factors. Area or volume are the factors used for centroids, weight for center of gravity, and mass for center of mass.

Example 7.1.1 Course Grades.

The mechanics syllabus says that there are two exams worth 25% each, homework is 10%, and the final is worth 40%. You have a 40 on the first exam, a 80 on the second exam, and your homework grade is 90.

What do you have to earn on the final exam to get a 70 in the class?

Solution. Your known grades and the weighting factors are

$$G_i = [40, 80, 90, FE]$$

$$w_i = [25\%, 25\%, 10\%, 40\%]$$

Find final exam score FE so that your average grade \bar{G} is 70%.

$$\bar{G} = \frac{\sum G_i w_i}{\sum w_i}$$

$$70 = \frac{(40 \times 0.25) + (80 \times 0.25) + (90 \times 0.1) + (FE \times 0.4)}{(0.25 + 0.25 + 0.1 + 0.4)}$$

$$FE = \frac{70(1) - (10 + 20 + 9)}{0.4} = 77.5$$

7.2 Center of Gravity

So far in this book we have always taken the weight of an object to act at a point at its center. This is the **center of gravity**: the point where all of an object's weight may be concentrated and still have the same *external* effect on the body. In this chapter we will learn to actually locate this point.

We will indicate the center of gravity with a circle with black and white quadrants, and call its coordinates (\bar{x}, \bar{y}) or $(\bar{x}, \bar{y}, \bar{z})$. This point represents the average location of all the particles which make up the body.

The center of gravity of a body is fixed with respect to the body, but the coordinates depend on the choice of coordinate system. For example, in [Figure 7.2.1](#) the center of gravity of the block is at its geometric center meaning that \bar{x} and \bar{y} are positive, but if the block is moved to the left of the y axis, or the coordinate system is translated to the right of the block, \bar{x} would then become negative.

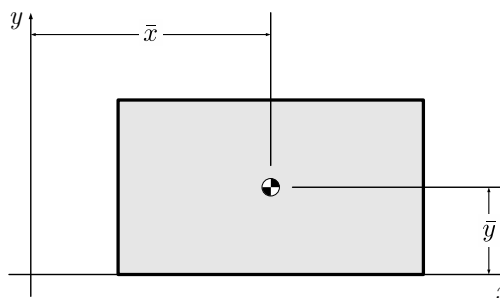

Figure 7.2.1 Location of the centroid, measured from the origin.

Lets explore the center of gravity of a familiar object. Take a pencil and try to balance it on your finger. How do you decide where to place it? You likely supported it roughly in the middle, then adjusted it until it balanced. You found the point where the moments of the weights on either side of your finger were in equilibrium.

Let's develop this balanced moment idea mathematically.

Assume that the two halves of the pencil have known weights acting at points 1 and 2. How could we replace the two weights with a single statically equivalent force? Recall from [Section 4.7](#) that statically equivalent systems produce the

same external effect on the object —the net force on the object, and the net moment about any point don't change. An upward force at this point will support the pencil without tipping.

To be equivalent, the total weight must equal the total weight of the parts. $W = W_1 + W_2$. Common sense also tells us that W will act somewhere between W_1 and W_2 .

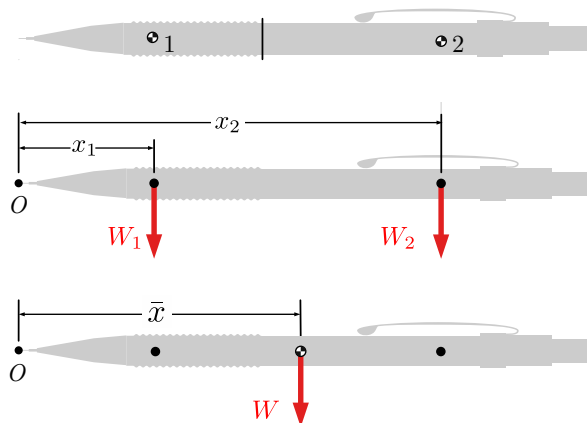

Figure 7.2.2 (top) Side view of a pencil representing each half as a particle. (middle) A force diagram showing the weights of the two particles. (bottom) An equivalent system consisting of a single weight acting at the pencil's center of gravity.

Next, let's do the mathematical equivalent of sliding your finger back and forth until a balance point is located. Pick any point O to be the origin, then calculate the total moment about O due to the two weights.

The sum of moments around point O can be written as:

$$\sum M_O = -x_1W_1 - x_2W_2$$

Notice that the moment of both forces are clockwise around point O , so the signs are negative according to the right-hand rule. We want a single equivalent force acting at the (unknown) center of gravity. Call the distance from the origin to the center of gravity \bar{x} .

\bar{x} represents the mean distance of the weight, mass, or area depending on the context of the problem. We are evaluating weights in this problem, so \bar{x} represents the distance from O to the center of gravity.

The sum of moments around point O for the equivalent system can be written as:

$$\sum M_O = -\bar{x}W$$

The moment of total weight W is also clockwise around point O , so the sign of moment will also be negative according to the right-hand rule. Since the two representation are equivalent we can equate them and solve for \bar{x} .

$$-\bar{x}W = -x_1W_1 - x_2W_2$$

$$\bar{x} = \frac{x_1W_1 + x_2W_2}{W_1 + W_2}$$

This result is exactly in the form of (7.1.2) where the value being averaged is distance x and the weighting factor is the weight of part W_i and the result is the mean distance \bar{x} .

The pencil was made up of two halves, but this equation can easily be extended n discrete parts. The resulting general definition of the centroidal coordinate \bar{x} is:

$$\bar{x} = \frac{\sum \bar{x}_i W_i}{\sum W_i} \quad (7.2.1)$$

where:

W_i is the weight of part i ,

\bar{x}_i is the x coordinate of the center of gravity of element i , and

\sum is understood to mean “sum all parts” so there is no need to write $\sum_{i=1}^n$.

The numerator is the **first moment** of force which is literally a moment of force as we defined it in Chapter 3. The denominator is the sum of the weights of the pieces, which is the weight of the whole object. We will soon also see first moments of mass and first moments of area and in Chapter 10, we will introduce **second moments**, which are the integral of some quantity like area, multiplied by a distance *squared*.

We treated the pencil as a one-dimensional object, so this discussion focused on \bar{x} . There are similar formula for the other dimensions as well

$$\bar{x} = \frac{\sum \bar{x}_i W_i}{\sum W_i} \quad \bar{y} = \frac{\sum \bar{y}_i W_i}{\sum W_i} \quad \bar{z} = \frac{\sum \bar{z}_i W_i}{\sum W_i}. \quad (7.2.2)$$

In words, these equations say

$$\text{distance to CG} = \frac{\text{sum of first moments of weight}}{\text{total weight}}$$

They apply to any object which can be divided into discrete parts, and they produce the coordinates of the object’s center of gravity.

Question 7.2.3

Can you explain why the center of gravity of a symmetrical object will always fall on the axis of symmetry?

Answer. If the object is symmetrical, every subpart on the positive side of the axis of symmetry will be balanced by an identical part on the negative side. The first moment for the entire shape about the axis will sum

to zero, meaning that

$$\bar{x} = \frac{\sum \bar{x}_i W_i}{\sum W_i} = \frac{0}{W} = 0.$$

In other words, the distance from the axis of symmetry of the shape to the centroid is zero.

Example 7.2.4 Simple Center of Gravity.

Three boxes are distributed along the x axis as shown.

- Find the distance from the origin to the center of gravity of the system.
- How would the center of gravity change if the origin was moved to the right-hand box?

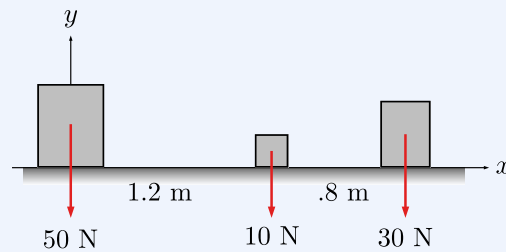

Solution. The center of gravity of the system is the point where the total weight can be considered to act.

The total weight is $W = \sum W_i = 90$ N, and it acts at the point where it produces the same total moment as the individual weights. In other words, it is an *equivalent system*. The moment comparison may be taken about any point, so for convenience we choose the origin.

Let x_i represent the x -coordinates of the individual weights, and \bar{x} represent the x -coordinate of the center of gravity. For both systems to be equivalent:

$$\begin{aligned} W \bar{x} &= \sum (W_i x_i) \\ (90 \text{ N}) \bar{x} &= (50 \text{ N})(0) + (10 \text{ N})(1.2 \text{ m}) + (30 \text{ N})(2.0 \text{ m}) \\ \bar{x} &= \frac{72 \text{ N}\cdot\text{m}}{90 \text{ N}} \\ &= 0.8 \text{ m} \end{aligned}$$

If the origin was moved to the right-hand box, the center of gravity would not change; however, the *coordinate* of the center of gravity would be different. The distance to the center of gravity from the new origin would be:

$$\bar{x} = \frac{(10 \text{ N})(-0.8 \text{ m}) + (50 \text{ N})(-2.0 \text{ m})}{90 \text{ N}} = -1.2 \text{ m}$$

7.3 Center of Mass

The **center of mass** is the mean location of the mass of an object, and is related to the center of gravity by Newton's Second Law because

$$W = mg,$$

where g is the local strength of the gravitational field. In this course you may take $g = 9.81 \text{ m/s}^2$ in the SI system, or $g = 32.2 \text{ ft/s}^2$ in the US customary system as reasonable approximations for objects on the surface of the earth.

Substituting $m_i g_i = W_i$ in (7.2.2) gives the equations for the center of mass.

$$\bar{x} = \frac{\sum \bar{x}_i m_i g_i}{\sum m_i g_i} \quad \bar{y} = \frac{\sum \bar{y}_i m_i g_i}{\sum m_i g_i} \quad \bar{z} = \frac{\sum \bar{z}_i m_i g_i}{\sum m_i g_i}. \quad (7.3.1)$$

By our assumption that g is constant on the surface of the earth, g_i can be factored out of the sums and drops out of the equation completely.

$$\bar{x} = \frac{\sum \bar{x}_i m_i}{\sum m_i} \quad \bar{y} = \frac{\sum \bar{y}_i m_i}{\sum m_i} \quad \bar{z} = \frac{\sum \bar{z}_i m_i}{\sum m_i}. \quad (7.3.2)$$

These equations give the coordinates of the center of mass. The numerator contains the **first moment of mass**, and the denominator contains the total mass of the object. As long as the assumption that g is constant is valid, the center of mass and the center of gravity are identical points and the two terms may be used interchangeably.

7.4 Centroids

Key Questions

- What is the difference between a centroid, center of gravity and a center of mass?
- When will the centroid, center of gravity and center of mass refer to the same point?
- Why do the equations for the center of gravity, mass, volume, and area all have the same structure?

A centroid is a weighted average like the center of gravity, but weighted with a geometric property like area or volume, and not a physical property like weight or mass. This means that centroids are properties of pure shapes, not physical objects. They represent the coordinates of the “middle” of the shape.

The defining equations for centroids are similar to the equations for [Centers of Gravity \(7.2.2\)](#) but with *volume* used as the weighting factor for three-dimensional shapes

$$\bar{x} = \frac{\sum \bar{x}_i V_i}{\sum V_i} \quad \bar{y} = \frac{\sum \bar{y}_i V_i}{\sum V_i} \quad \bar{z} = \frac{\sum \bar{z}_i V_i}{\sum V_i}, \quad (7.4.1)$$

and *area* for two-dimensional shapes

$$\bar{x} = \frac{\sum \bar{x}_i A_i}{\sum A_i} \quad \bar{y} = \frac{\sum \bar{y}_i A_i}{\sum A_i}. \quad (7.4.2)$$

We will see how to use these equations on complex shapes later in this chapter, but centroids of some simple shapes can be easily found using symmetry.

If the shape has an axis of symmetry, every point on one side of the axis is mirrored by another point equidistant on the other side. One has a positive distance from the axis, and the other is the same distance away in the negative direction. These two points will add to zero the numerator, as will every other point making up the shape, and the first moment will be zero. This means that the centroid must lie along the line of symmetry if there is one. If a shape has multiple symmetry lines, then the centroid must exist at their intersection.

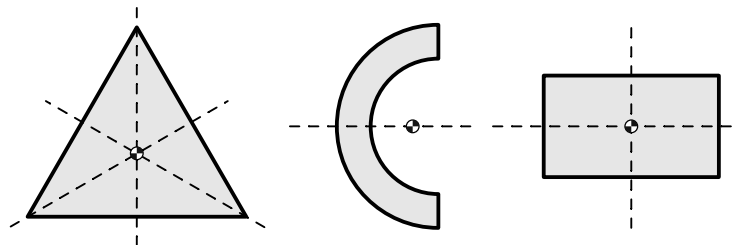
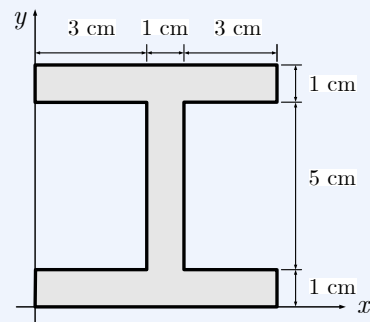

Figure 7.4.1 Centroids lie upon axes of symmetry.

Since rectangles, circles, cubes, spheres, etc. have multiple lines of symmetry, their centroids must be exactly in the center as we would expect.

Question 7.4.2

What are the coordinates of the centroid of the I beam section shown?



Answer.

$$\bar{x} = \bar{y} = 3.5 \text{ cm}$$

Solution. The cross section is symmetrical about both a vertical and horizontal centerline. The centroid is at the intersection, in the middle. The coordinates are measured from the origin, in the bottom left of the diagram.

$$\bar{x} = \bar{y} = 3.5 \text{ cm}$$

7.4.1 Properties of Common Shapes

We will learn how to find centroids of other shapes in [Section 7.7](#) using integration, but in the mean time several common shapes are recorded in the table below. This information in this table will be needed in the next section.

Table 7.4.3 Centroids of Common Shapes

Shape	Area	\bar{x}	\bar{y}
	$A = bh$	$b/2$	$h/2$
	$\frac{bh}{2}$	$b/3$	$h/3$
	$\frac{(a+b)h}{2}$	$\frac{a^2 + ab + b^2}{3(a+b)}$	$\frac{h(2a+b)}{3(a+b)}$
	πr^2	r	r
	$\frac{\pi r^2}{2}$	r	$\frac{4r}{3\pi}$
	$\frac{\pi r^2}{4}$	$\frac{4r}{3\pi}$	$\frac{4r}{3\pi}$

Note 7.4.4

In this table, all centroids are measured from the indicated origin. You must make the appropriate adjustments when the origin of your coordinate system is located elsewhere.

7.4.2 Relations between Centroids and Center of Gravity

The equations we have been discussing (7.2.2), (7.3.1), (7.4.1) and (7.4.2) are all variations on the general weighted average formula (7.1.2).

$$\bar{a} = \frac{\sum a_i w_i}{\sum w_i}$$

Here a_i represents the distance in one of the coordinate directions such as x , \bar{a} is the mean distance in the a direction to the ‘middle’ of the whole object, and w is the weighting factor. The only difference between them is the choice of weighting factor. For center of gravity, the weighting factor is the weight, for center of mass, it is the mass, for three dimensional centroids it is the volume, and for two dimensional centroids it is area.

To understand how these equations relate to one another consider a plate with a cross-sectional area A , divided into n pieces with volume V_i .

The weight of part i is the product of its specific weight and volume.

$$W_i = \gamma V_i = \rho_i g_i A_i t_i$$

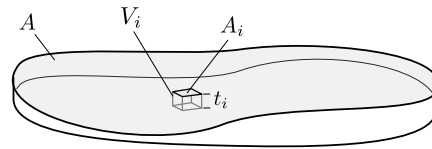

Figure 7.4.5 Plate with variable thickness t , divided into many volume elements V_i .

In the most general case, all of these terms might depend on the position of the part, but if any are constant they can be factored out and simplify the formulas.

For a homogeneous flat plate with uniform thickness, like a piece of plywood, the density, thickness and g are all constant so

$$W_i = \rho g t A_i$$

$$\begin{aligned} \bar{x} &= \frac{\sum \bar{x}_i W_i}{\sum W_i} & \bar{y} &= \frac{\sum \bar{y}_i W_i}{\sum W_i} & \bar{z} &= \frac{\sum \bar{z}_i W_i}{\sum W_i} \\ \bar{x} &= \frac{\rho g t \sum \bar{x}_i A_i}{\rho g t \sum A_i} & \bar{y} &= \frac{\rho g t \sum \bar{y}_i A_i}{\rho g t \sum A_i} & \bar{z} &= \frac{\rho g t \sum \bar{z}_i A_i}{\rho g t \sum A_i} \end{aligned}$$

¹See [Example 7.7.14](#) for proof. $\frac{4r}{3\pi} \approx 0.424 r$

The two dimensional centroid equations are sufficient to find the center of gravity of a three dimensional object.

7.5 Centroids using Composite Parts

Key Questions

- How do you calculate the center of gravity of a system of separate objects?
- Where do the equations for the shapes in areas and centroids table come from?
- When finding the centroid, what do you do with a cut-out area of a composite part?
- Does it matter whether a distance to the centroid of a part is positive or negative from the axis system?

In this section we will discuss how to find centroids of two-dimensional shapes by first dividing them into pieces with known properties, and then combining the pieces to find the centroid of the original shape. This method will work when the geometric properties of all the sub-shapes are known or can be easily determined. If the shape can't be decomposed this way, perhaps because it has a curved boundary, you will need to use integration to find the centroid. Integration will be covered in [Section 7.7](#).

For convenience, the properties of several common shapes can be found [here](#).

7.5.1 Composite Parts Method

The equations we will use for this approach are

$$\bar{x} = \frac{\sum \bar{x}_i A_i}{\sum A_i} \quad \bar{y} = \frac{\sum \bar{y}_i A_i}{\sum A_i} \quad (7.5.1)$$

where,

\bar{x} , and \bar{y} are the coordinates of the centroid of the entire shape.

A_i is the area of composite part i .

\bar{x}_i , and \bar{y}_i are the coordinates of the centroid of composite part i .

The steps to finding a centroid using the composite parts method are:

1. Break the overall shape into simpler parts.
2. Collect the areas and centroid coordinates, and

- Apply (7.5.1) to combine to find the coordinates of the centroid of the original shape.

As a simple example, consider the L-shaped area shown, which has been divided into two rectangles. The areas of the rectangles are

$$A_1 = 18 \text{ in}^2, A_2 = 14 \text{ in}^2$$

The origin is located at the lower left, so the coordinates of the centroids of the two rectangles are

$$\bar{x}_1 = 1.5 \text{ in}, \bar{y}_1 = 5 \text{ in}, \quad \bar{x}_2 = 3.5 \text{ in}, \bar{y}_2 = 1 \text{ in}$$

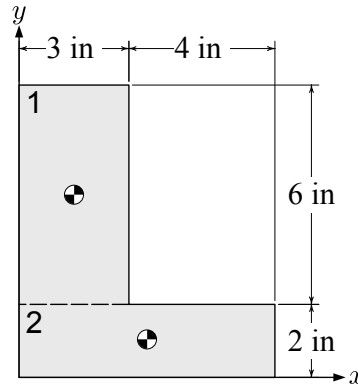

The centroid of the whole shape is found by applying (7.5.1)

$$\begin{aligned} \bar{x} &= \frac{\sum \bar{x}_i A_i}{\sum A_i} & \bar{y} &= \frac{\sum \bar{y}_i A_i}{\sum A_i} \\ \bar{x} &= \frac{(1.5)(18) + (3.5)(14)}{18 + 14} & \bar{y} &= \frac{\sum (5)(18) + (1)(14)}{18 + 14} \\ \bar{x} &= 2.375 \text{ in} & \bar{y} &= 3.25 \text{ in} \end{aligned}$$

For more complex shapes, the usual practice is to set up a table to organize the information needed to calculate the centroid, as we will now show. The process can be broken into three steps.

- Break the overall shape into simpler parts.

We begin with a sketch of the shape and establish a coordinate system. It is critical that all measurements are made from a common origin, and the results will be measured from this origin as well. A careful choice of origin can simplify the problem, so give it some thought.

Then divide the shape into several simpler shapes. The sub-shapes may include holes, which are treated as negative areas. You must know how to calculate the area and locate the centroid of any sub-shape you use.

Consider the complex shape below.

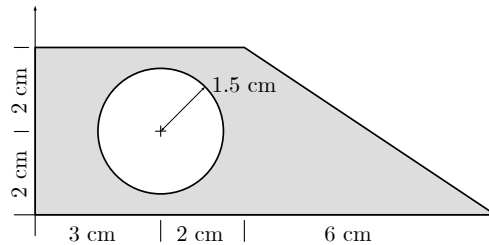

There are often several ways to divide a shape, but it's best to use as few parts as possible to minimize your computations and opportunities for

error. For example, you could choose to break this shape into either a $5\text{ cm} \times 4\text{ cm}$ rectangle, a $6\text{ cm} \times 4\text{ cm}$ right triangle, and an $r = 1.5\text{ cm}$ circular hole,

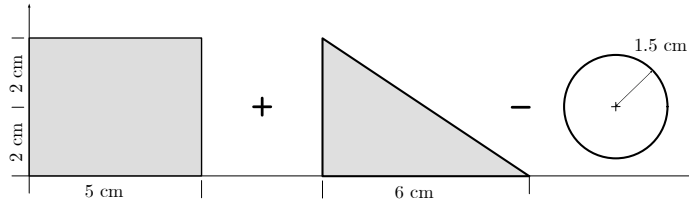

or a large $11\text{ cm} \times 4\text{ cm}$ rectangle, an $r = 1.5\text{ cm}$ circular hole, and a $6\text{ cm} \times 4\text{ cm}$ right triangle subtracted from the large rectangle.

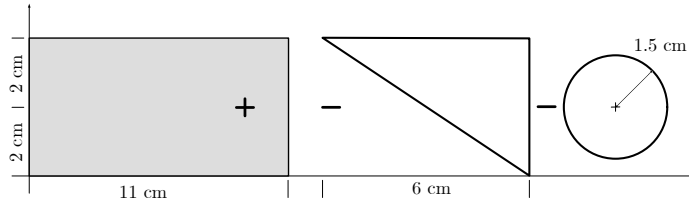

Both options will give the same results, and in this case there is no particular advantage to one choice over the other. However, it would be silly and unnecessary to break this into more than three parts, and it would not be a good idea to divide this into a trapezoid minus a hole, unless you know geometric properties of a trapezoid, which are not available in [Subsection 7.4.1](#). Be sure your sub-shapes don't overlap and don't get counted more than once.

2. *Collect the areas and centroid coordinates.*

Once the complex shape has been divided into parts, the next step is to determine the area and centroidal coordinates for each part. You can use the properties in [Subsection 7.4.1](#) for rectangles, triangles, circles, semi-circles and quarter circles but you will need to use integration if other shapes are involved. Any holes or removed shapes should be treated as negative areas.

Record the information you gather in a table like the one below. The table should include a row containing column headings and units, one row for each part, and a summary row. The first column identifies the part — by number or sketch, the second contains the areas, and the third and fourth contains the centroidal coordinates of the parts.

Part	A_i [cm ²]	\bar{x}_i [cm]	\bar{y}_i [cm]	$A_i\bar{x}_i$ [cm ³]	$A_i\bar{y}_i$ [cm ³]
1	20	2.5	2	50	40
2	12	7	4/3	84	16
3	-2.25π	3	2	-6.75π	-4.5π
Σ	24.93	—	—	112.8	41.86

The last two columns of the table contain the first moments of area $Q_x = A_i \bar{y}_i$ and $Q_y = A_i \bar{x}_i$, and are easily filled in by multiplying the values in columns two to four. Be sure to attend to positive and negative signs when multiplying. Note that the moment of area with respect to the x axis uses the distance from the x axis, which is \bar{y}_i , and vice-versa.

The final row of the table are total values, calculated by summing the entries for A_i , Q_x and Q_y , so for example the total area of the shape is

$$A = \sum A_i = A_1 + A_2 + A_3 \dots$$

Don't sum columns three or four, since $\sum \bar{x}_i$ and $\sum \bar{y}_i$ are meaningless.

3. *Combine the pieces to find the overall centroid.*

After you have filled in the whole table, you can find the coordinates of the centroid by applying (7.5.1) with the summary values from the last row.

$$\begin{aligned} \bar{x} &= \frac{Q_y}{A} &= \frac{112.8}{24.93} &= 4.52 \text{ cm} \\ \bar{y} &= \frac{Q_x}{A} &= \frac{41.86}{24.93} &= 1.692 \text{ cm} \end{aligned}$$

Finally, plot the centroid (\bar{x}, \bar{y}) on the diagram. If you have made a calculation error it will usually be obvious, because the centroid location won't "feel right."

The next interactive shows a composite shape consisting of a large rectangle with a smaller rectangle subtracted. You can change the location and size of the rectangles by moving the red points. Use this to visualize how the centroids of the whole is related to the centroid of the parts. Note that for objects divided into two pieces, the centroid of the whole always falls on the line connecting the centroids of the parts.

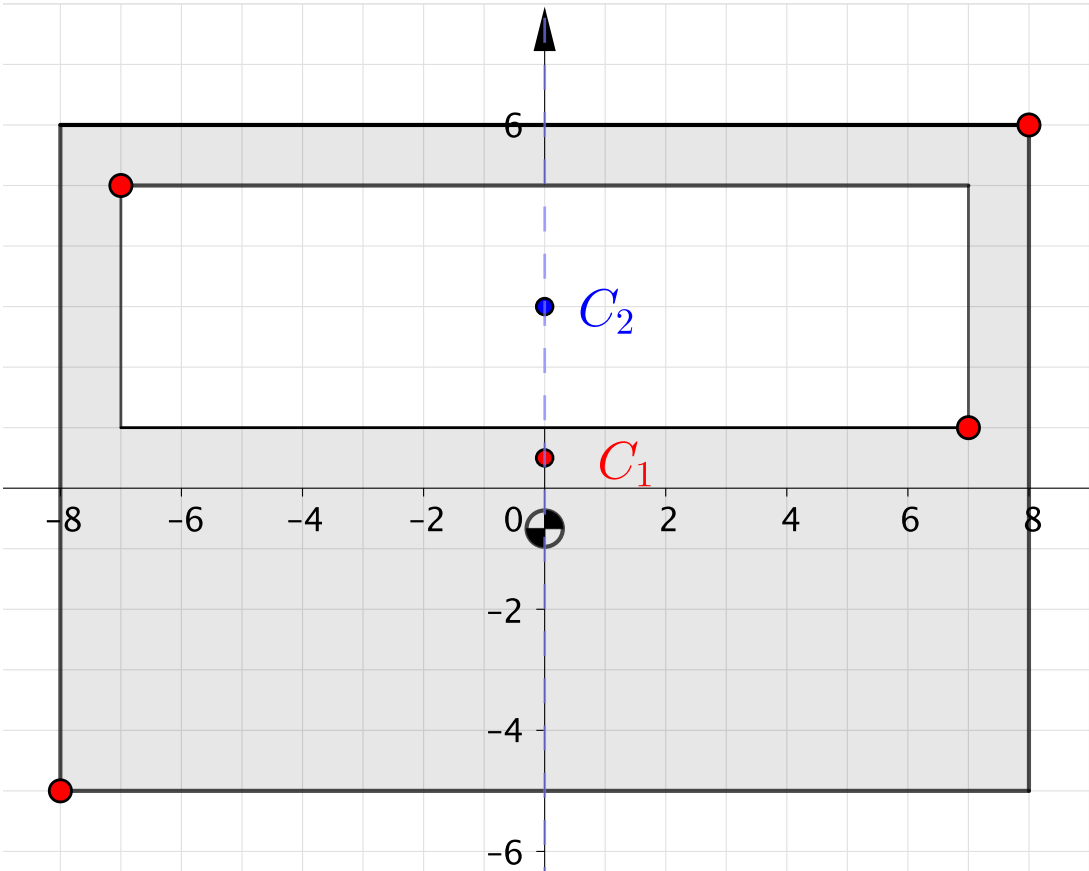

[Live Link](#)

Figure 7.5.1 Centroid of Composite Rectangles

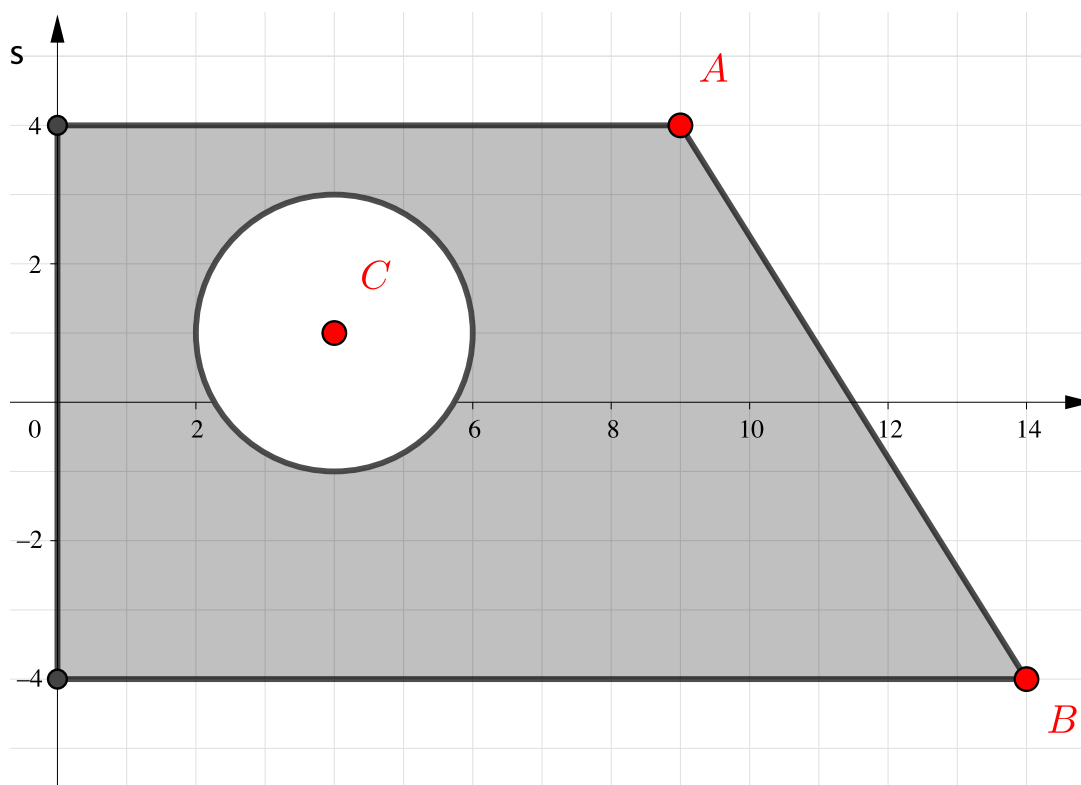

[Live Link](#)

Figure 7.5.2 Centroid of a body consisting of a rectangle, triangle and a circular hole.

7.5.2 Centroids of 3D objects

Key Questions

- How do you divide a composite solid into parts and compute the volume/mass and centroidal distances of each part?
- What is the technique to compute the overall center of volume/mass for a composite solid?

The centroid of a three-dimensional volume is found similarly to two-dimensional centroids, but with volume used instead of area for the weighting factor. The centroid of a volume and the center of mass or gravity for a homogenous solid are identical.

$$\bar{x} = \frac{\sum \bar{x}_i V_i}{\sum V_i} \quad \bar{y} = \frac{\sum \bar{y}_i V_i}{\sum V_i} \quad \bar{z} = \frac{\sum \bar{z}_i V_i}{\sum V_i}$$

Where,

\bar{x} , \bar{y} , and \bar{z} are the coordinates of the centroid of the overall volume. V_i is the volume of composite part i .

\bar{x}_i , \bar{y}_i , and \bar{z}_i is the coordinates of the centroid of composite part i .

Many three-dimensional shapes are just prismatic extrusions of the shapes. The volume of a prism is the product of the cross-sectional area and the length of the prism and is easily calculated. For example, the volume of a circular cylinder with radius r and length l is $V = \pi r^2 l$.

If the density varies for each part of a composite solid, we can find the center of mass by dividing the first moment of mass by the total mass. You can also compute the center of gravity by replacing the mass terms in the equations below with weight terms.

$$\bar{x} = \frac{\sum \bar{x}_i m_i}{\sum m_i} \qquad \bar{y} = \frac{\sum \bar{y}_i m_i}{\sum m_i} \qquad \bar{z} = \frac{\sum \bar{z}_i m_i}{\sum m_i}$$

Here m_i is the mass of composite part i .

You must always use the same weighting factor (area, volume, mass, weight, etc) in both the numerator and denominator of the center of area/volume/mass/weight equations.

Example 7.5.3 3D Center of Mass.

A composite solid consists of a rectangular block of lightweight concrete and a triangular wedge of steel with dimensions as shown. The rectangular block has a 2 ft radius circular hole, centered and drilled through its full depth, perpendicular to the front and back faces.

Assume $\gamma_C = 125 \text{ lb/ft}^3$, and $\gamma_S = 493 \text{ lb/ft}^3$.

Find the center of mass of this composite solid.

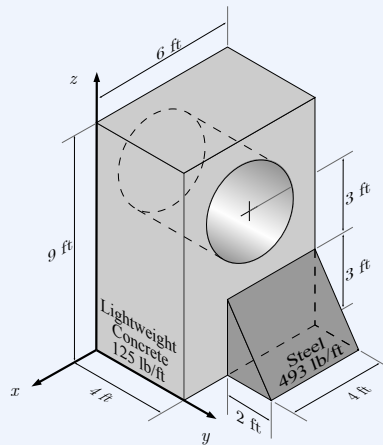

Solution.

Table 7.5.4

Part	V_i [ft ³]	γ [lb/ft ³]	W_i [lb]	\bar{x}_i [ft]	\bar{y}_i [ft]	\bar{z}_i [ft]	$W_i \bar{x}_i$ [ft·lb]	$W_i \bar{y}_i$ [ft·lb]	$W_i \bar{z}_i$ [ft·lb]
block	216	125	27000	-3	2	4.5	-81000	54000	121500
hole	-50.27	125	-6283	-3	2	6	18850	-12566	-37699
wedge	12	493	5916	-4	4.67	1	-23664	27608	5916
			26633				-85814	69042	89717

$$\begin{aligned}\bar{x} &= \frac{\sum W_i \bar{x}_i}{\sum W_i} &= \frac{-85814 \text{ ft}\cdot\text{lb}}{26633 \text{ lb}} &= -3.22 \text{ ft} \\ \bar{y} &= \frac{\sum W_i \bar{y}_i}{\sum W_i} &= \frac{69042 \text{ ft}\cdot\text{lb}}{26633 \text{ lb}} &= 2.59 \text{ ft} \\ \bar{z} &= \frac{\sum W_i \bar{z}_i}{\sum W_i} &= \frac{89717 \text{ ft}\cdot\text{lb}}{26633 \text{ lb}} &= 3.37 \text{ ft}\end{aligned}$$

We have actually found the coordinates of the center of gravity, but since g is constant they are also coordinates of the center of mass.

7.6 Average Value of a Function

The weighted average technique discussed in (7.1.2) are a fine for averaging several discrete values, but what do we do if we need to find the average of an infinite number of values or values which change continuously?

Consider a function $y = f(x)$ over some interval from a to b . How can we find the average value \bar{y} of the function over that interval? To understand what is meant by the average value of a function, look at the interactive below. There, the function $f(x)$ is the red curve, and which you can change if you like. The blue dots a and b mark the beginning and end of the interval and are also adjustable.

The area under this curve between a and b is shaded with gray, and we can find it using a definite integral

$$\int_a^b f(x) dx$$

The blue hatched rectangle has the same area as the gray shaded region, and because the areas are the same, the height of the rectangle \bar{y} , is the average value of $f(x)$.

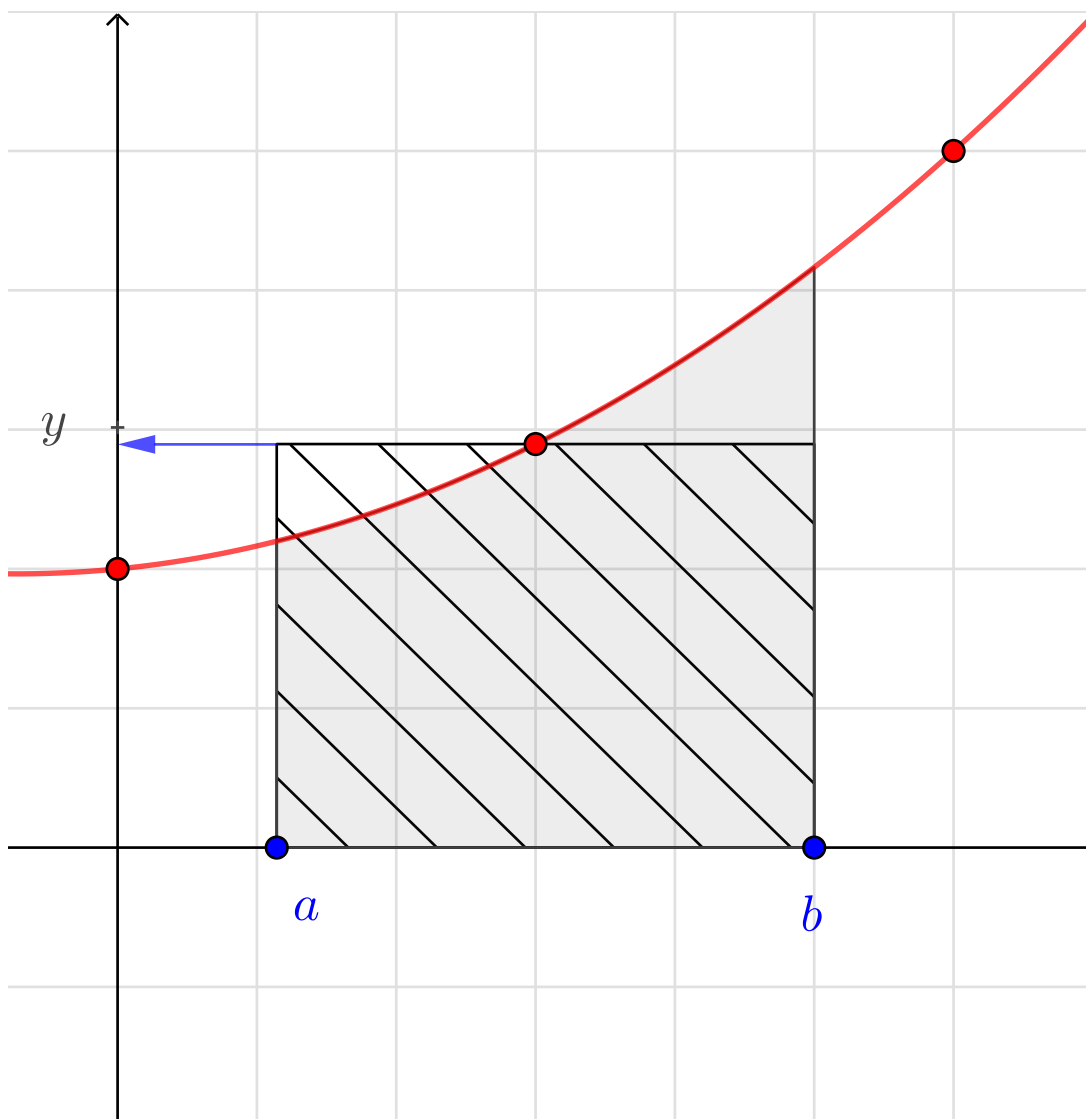

[Live Link](#)

Figure 7.6.1 The average value of a function between a and b .

With this in mind, we can calculate the average value of $f(x)$ by equating the area under the curve with the area of the rectangle and solving for \bar{y} .

$$\int_a^b f(x) dx = \bar{y}(b - a)$$

$$\bar{y} = \frac{\int_a^b f(x) dx}{(b - a)}$$

$$\bar{y} = \frac{\int_a^b f(x) dx}{\int_a^b dx}$$

and since $\int_a^b dx = (b - a)$

This is a weighted average like (7.1.2) but instead of summing n discrete values, we integrate of an infinite number of infinitesimal values. $f(x)$ is the value being averaged and the weighting function is dx .

This approach is true for any choice of weighting function. To find \bar{x} for a two dimensional area, the value to be averaged is x and the weighting function is dA , so replacing dx with dA and x_i with x ,

$$\bar{x} = \frac{\sum \bar{x}_i A_i}{\sum A_i} \quad \Rightarrow \quad \bar{x} = \frac{\int x dA}{\int dA}$$

In other words, to transform a discrete summation to an equivalent continuous integral form you:

1. Replace the summation with integration, $\Sigma \Rightarrow \int$.
2. Replace the discrete weighting factor with the corresponding differential element,

$$\begin{cases} A_i & \Rightarrow dA \\ V_i & \Rightarrow dV \\ W_i & \Rightarrow dW \end{cases} \quad \text{etc.}$$

3. Rename the value being averaged to eliminate the index i . We often use el as a subscript when referring to a differential element.

The two-dimensional centroid equations (7.5.1) become,

$$\bar{x} = \frac{\sum \bar{x}_i A_i}{\sum A_i} \Rightarrow \frac{\int \bar{x}_{el} dA}{\int dA} \quad \bar{y} = \frac{\sum \bar{y}_i A_i}{\sum A_i} \Rightarrow \frac{\int \bar{y}_{el} dA}{\int dA}$$

, and in the same way the center of gravity equations become

$$\bar{x} = \frac{\int \bar{x}_{el} dW}{\int dW} \quad \bar{y} = \frac{\int \bar{y}_{el} dW}{\int dW} \quad \bar{z} = \frac{\int \bar{z}_{el} dW}{\int dW}$$

Question 7.6.2

How far is it from the earth to the sun?

Answer. 92,958,412 miles

Solution. Siri says that “The average distance from the earth to the sun is 92,958,412 miles.”

That’s a pretty exact answer. What does it mean, exactly? From what point on the earth to what point on the sun?

If the earth and sun were perfect spheres, we could use the distance between their centroids. With more information about shape and density, we could find their centers of mass and measure between those points.

The bigger problem is that this distance changes continuously as the earth revolves around the sun. How can we find an average value for something which is continuously changing?

We need to use the methods described here, integrating the distance as a function of time over the course of a year.

7.7 Centroids using Integration

Key Questions

- How do you find the centroid of an area using integration?
- What is a differential quantity?
- Why are double integrals required for square dA elements and single integrals required for rectangular dA elements?

In this section we will use the integral form of (7.4.2) to find the centroids of non-homogenous objects or shapes with curved boundaries.

$$\bar{x} = \frac{\int \bar{x}_{el} dA}{\int dA} \quad \bar{y} = \frac{\int \bar{y}_{el} dA}{\int dA} \quad \bar{z} = \frac{\int \bar{z}_{el} dA}{\int dA} \quad (7.7.1)$$

With the integral equations we are mathematically breaking up a shape into an infinite number of infinitesimally small pieces and adding them together by integrating. This powerful method is conceptually identical to the discrete sums we introduced first.

7.7.1 Integration Process

Determining the centroid of a area using integration involves finding weighted average values \bar{x} and \bar{y} , by evaluating these three integrals,

$$A = \int dA, \quad Q_x = \int \bar{y}_{el} dA \quad Q_y = \int \bar{x}_{el} dA \quad (7.7.2)$$

, where

- dA is a differential bit of area called the *element*.
- A is the *total area* enclosed by the shape, and is found by evaluating the first integral.
- \bar{x}_{el} and \bar{y}_{el} are the coordinates of the *centroid of the element*. These are frequently functions of x or y , not constant values.

- Q_x and Q_y are the *First moments of Area* with respect to the x and y axis.

The procedure for finding centroids with integration can be broken into three steps:

1. *Set up the integrals.*

Usually this is the hardest step.

You should always begin by drawing a sketch of the problem and reviewing the given information.

You will need to understand the boundaries of the shape, which may be lines or functions. You may need to know some math facts, like the definition of slope, or the equation of a line or parabola. A bounding function may be given as a function of x , but you want it as a function of y , or vice-versa or it may have a constant which you will need to determine.

You will need to choose an element of area dA . There are several choices available, including vertical strips, horizontal strips, or square elements; or in polar coordinates, rings, wedges or squares. There really is no right or wrong choice; they will all work, but one may make the integration easier than another. The best choice depends on the nature of the problem, and it takes some experience to predict which it will be.

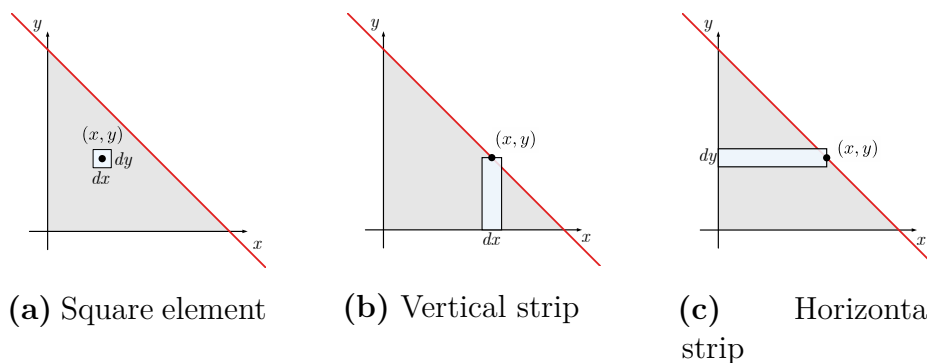

Figure 7.7.1 Differential Elements of Area

The two most common choices for differential elements are:

- *Square elements and double integrals.*

If you choose an infinitesimal square element $dA = dx dy$, you must integrate twice, over x and over y between the appropriate integration limits. The position of the element typically designated (x, y) .

- *Rectangular elements and single integrals.*

If you choose rectangular strips you eliminate the need to integrate twice. You may select a vertical element with a different width dx , and a height extending from the lower to the upper bound, or a horizontal strip with a differential height dy and a width extending from the left to the right boundaries. Either way, you only integrate once to cover the enclosed area.

When finding the area enclosed by a single function $y = f(x)$, and the x and y axes (x, y) represents a point on the function and $dA = y dx$ for vertical strips, or $dA = x dy$ for horizontal strips.

You must find expressions for the area dA and centroid of the element $(\bar{x}_{el}, \bar{y}_{el})$ in terms of the bounding functions. This is how we turn an integral over an area into a definite integral which can be integrated.

When you have established all these items, you can substitute them into (7.7.2) and proceed to the integration step.

2. Solve the integrals.

This step is pure mathematics.

Here are some tips if you are doing integration “by hand”. Be neat, work carefully, and check your work as you go along. Use proper mathematics notation: don’t lose the differential dx or dy before the integration step, and don’t include it afterwards. Don’t forget to use equals signs between steps. Simplify as you go and don’t substitute numbers or other constants too soon. Pay attention to units: Area A should have units of $[\text{length}]^2$ and the first moments of area Q_x and Q_y should have units of $[\text{length}]^3$. If your units aren’t consistent, then you have made a mistake.

3. Evaluate the centroid.

After you have evaluated the integrals you will have expressions or values for A , Q_x , and Q_y . All that remains is to substitute these into the defining equations for \bar{x} and \bar{y} and simplify. Notice the Q_x goes into the \bar{y} equation, and vice-versa.

$$\bar{x} = \frac{Q_y}{A} \qquad \bar{y} = \frac{Q_x}{A}$$

Finally, plot the centroid at (\bar{x}, \bar{y}) on your sketch and decide if your answer makes sense for area.

Thinking Deeper 7.7.2 What is dA ?

dA is just an area, but an extremely tiny one!

It’s an example of an **differential quantity**—also called an **infinitesimal**. A differential quantity is a value which is as close to zero as it can possibly be without actually being zero. You can think of its value as $\frac{1}{\infty}$. Integration is the process of adding up an infinite number of infinitesimal quantities.

Some other differential quantities we will see in statics are dx , dy and dz , which are infinitesimal increments of distance; dV , which is a differential volume; dW , a differential weight; dm , a differential mass, and so on.

Any product involving a differential quantity is itself a differential quantity,

so if the area of a vertical strip is given by $dA = y dx$ then, even though height y is a real number, the area is a differential because dx is differential. If you like, you can pronounce the d as “the little bit of” so $dA = y dx$ reads “The little bit of area is the height y times a little bit of x .” and $A = \int dA$ reads “The total area is the sum of the little bits of area.”

7.7.2 Area of a General Spandrel

In this section we will use the integration process describe above to calculate the area of the general spandrel shown in [Figure 7.7.3](#). A **spandrel** is the area between a curve and a rectangular frame. This is a general spandrel because the curve is defined by the function $y = kx^n$, where n is not specified. If $n = 0$ the function is constant, if $n = 1$ then it is a straight line, $n = 2$ it's a parabola, etc. You can change the slider in the interactive below to see the effect of different values of n .

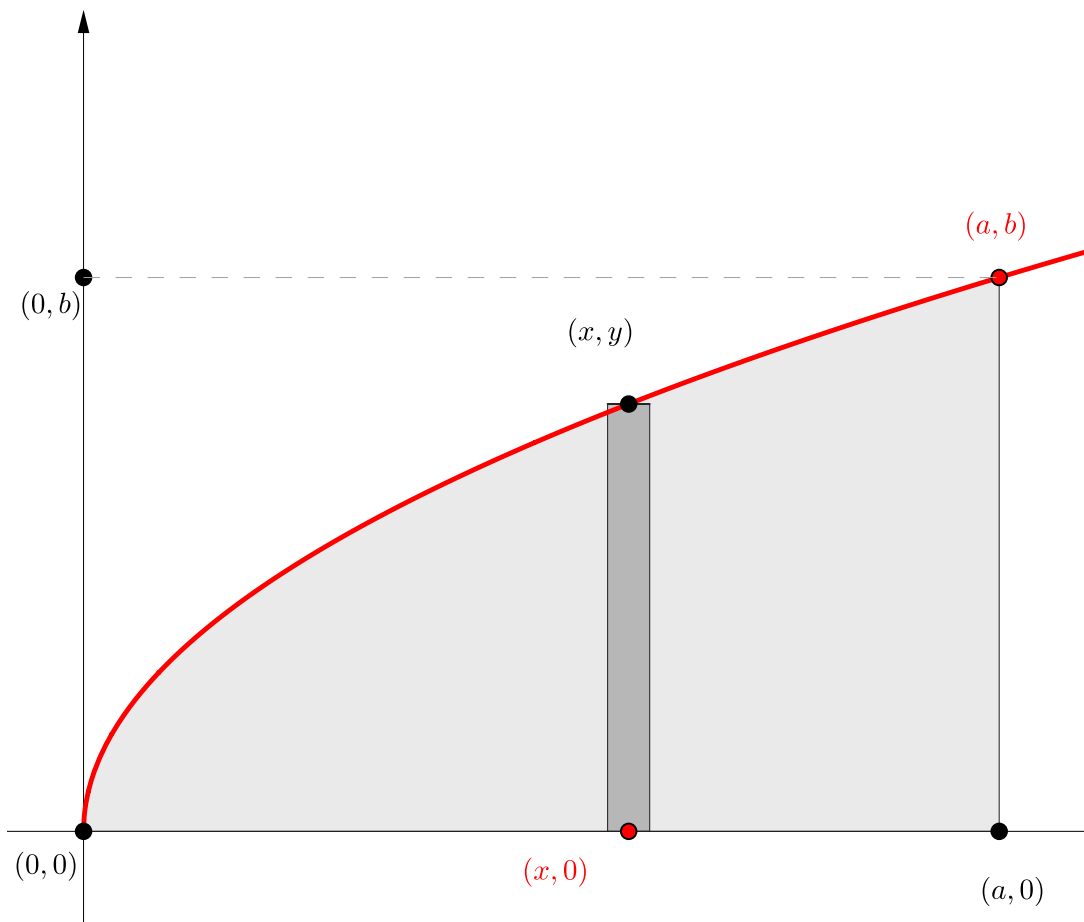

[Live Link](#)

Figure 7.7.3 A general spandrel of the form $y = kx^n$.

Begin by identifying the bounding functions. From the diagram, we see that the boundaries are the function, the x axis and, the vertical line $x = b$. The function $y = kx^n$ has a constant k which has not been specified, but which is not arbitrary. The diagram indicates that the function passes through the origin and point (a, b) , and there is only one value of k which will cause this. We can find k by substituting a and b into the function for x and y then solving for it.

$$\begin{aligned} y &= kx^n \\ b &= ka^n \\ k &= \frac{b}{a^n} \end{aligned}$$

Next, choose a differential area. For this problem a vertical strip works well. A vertical strip has a width dx , and extends from the bottom boundary to the

top boundary. Any point on the curve is (x, y) and a point directly below it on the x axis is $(x, 0)$. This means that the height of the strip is $(y - 0) = y$ and the area of the strip is (base \times height), so

$$dA = y \, dx.$$

The limits on the integral are from $x = 0$ on the left to $x = a$ on the right since we are integrating with respect to x .

With these details established, the next step is to set up and evaluate the integral $A = \int dA = \int_0^a y \, dx$. This is the familiar formula from calculus for the area under a curve. Proceeding with the integration

$$\begin{aligned} A &= \int dA && (dA = y \, dx) \\ &= \int_0^a y \, dx && (y = kx^n) \\ &= \int_0^a kx^n \, dx && (\text{integrate}) \\ &= k \left. \frac{x^{n+1}}{n+1} \right|_0^a && (\text{evaluate limits}) \\ &= k \frac{a^{n+1}}{n+1} && \left(k = \frac{b}{a^n} \right) \\ &= \frac{b}{a^n} \frac{a^{n+1}}{n+1} && (\text{simplify}) \\ A &= \frac{ab}{n+1} && (\text{result}) \end{aligned}$$

This result is not a number, but a general formula for the area under a curve in terms of a , b , and n . Explore with the interactive, and notice for instance that when $n = 0$, the shape is a rectangle and $A = ab$; when $n = 1$ the shape is a triangle and the $A = ab/2$; when $n = 2$ the shape is a parabola and $A = ab/3$ etc. This single formula gives the equation for the area under a whole family of curves.

Thinking Deeper 7.7.4 Which is better, horizontal or vertical elements?

Recall that the first moment of area $Q_x = \int \bar{x}_{\text{el}} \, dA$ is the distance weighted area as measured from a desired axis. The distance term \bar{x}_{el} is the distance from the desired axis to the centroid of each differential element of area, dA .

If you're using a single integral with a *vertical* element dA

$$dA = \underbrace{f(x)}_{\text{height}} (\underbrace{dx}_{\text{base}}) = y dx$$

and the horizontal distance from the y axis to the centroid of dA would simply be

$$\bar{x}_{\text{el}} = x.$$

It is also possible to find \bar{x} using a horizontal element but the computations are a bit more challenging. First the equation for dA changes to

$$dA = \underbrace{g(y)}_{\text{base}} (\underbrace{dy}_{\text{height}}) = x dy.$$

Additionally \bar{x}_{el} , must measure the distance to the centroid of the horizontal element. For these horizontal strips,

$$\bar{x}_{\text{el}} = \frac{x}{2}.$$

Similarly

$$\bar{y}_{\text{el}} = y$$

for horizontal elements, but

$$\bar{y}_{\text{el}} = \frac{y}{2}$$

for vertical elements.

With these modifications either strip can be used to find the area and centroid of a shape.

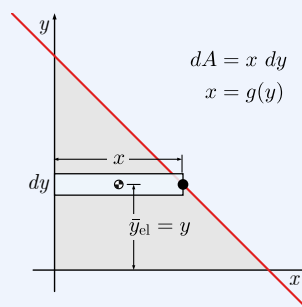
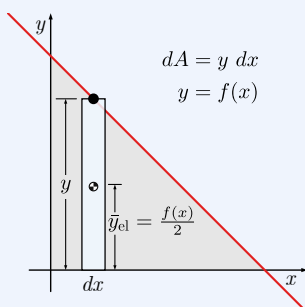

The interactive below compares horizontal and vertical strips for a shape bounded by the parabola $y^2 = x$ and the diagonal line $y = x - 2$. Horizontal strips are a better choice in this case, because the left and right

boundaries are easy to express as functions of y . If vertical strips are chosen, the parabola must be expressed as two different functions of x , and two integrals are needed to cover the area, the first from $x = 0$ to $x = 1$, and the second from $x = 1$ to $x = 4$.

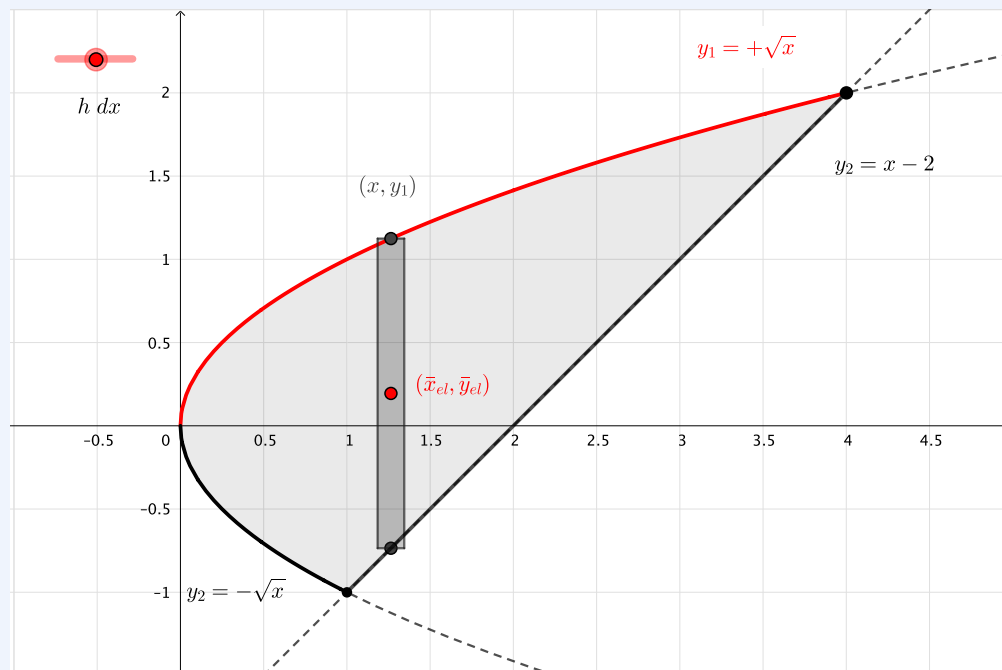

[Live Link](#)

Figure 7.7.5 Function demonstrating good and bad choices of differential elements.

7.7.3 Examples

This section contains several examples of finding centroids by integration, starting with very simple shapes and getting progressively more difficult. All the examples include interactive diagrams to help you visualize the integration process, and to see how dA is related to x or y .

The first two examples are a rectangle and a triangle evaluated three different ways: with vertical strips, horizontal strips, and using double integration. The different approaches produce identical results, as you would expect. You should try to decide which method is easiest for a particular situation.

Example 7.7.6 Centroid of a rectangle.

Use integration to show that the centroid of a rectangle with a base b and a height of h is at its center.

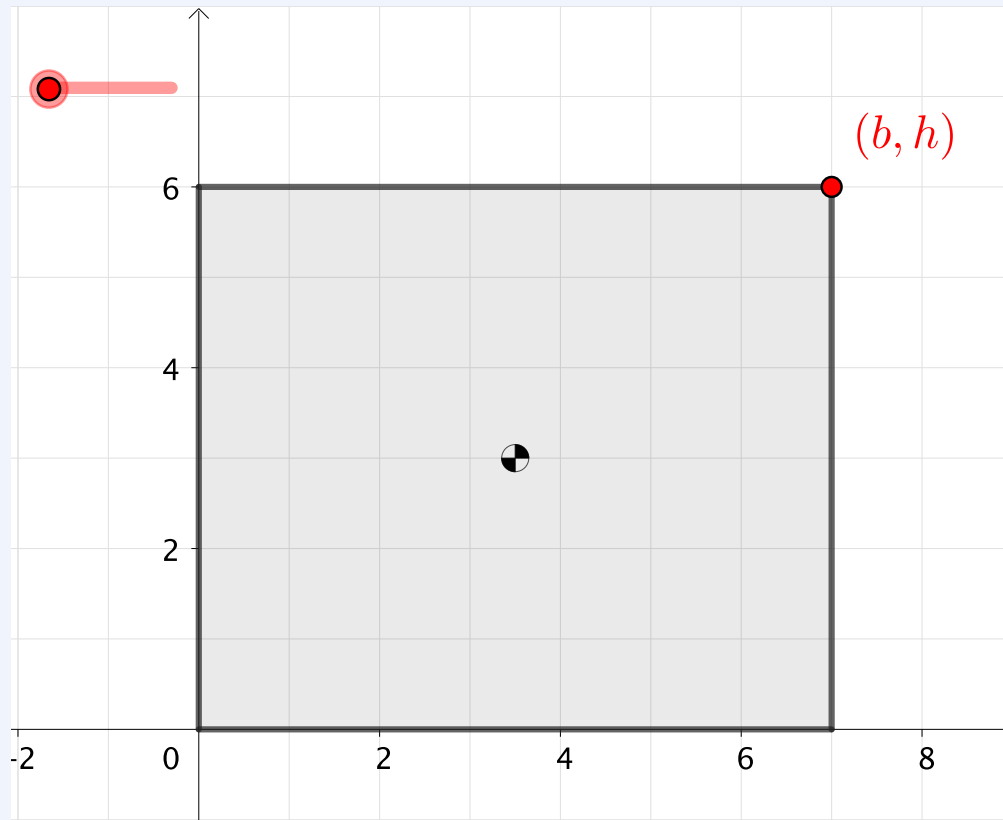

[Live Link](#)

Figure 7.7.7

Solution 1. This solution demonstrates solving integrals using vertical rectangular strips. Set the slider on the diagram to $h \, dx$ to see a representative element.

1. *Set up the integrals.*

The bounding functions in this example are vertical lines $x = 0$ and $x = a$, and horizontal lines $y = 0$ and $y = h$.

The strip extends from $(x, 0)$ on the x axis to (x, h) on the top of the rectangle, and has a differential width dx .

The area of the strip is the base times the height, so

$$dA = h \, dx.$$

The centroid of the strip is located at its midpoint so, by inspection

$$\begin{aligned}\bar{x}_{\text{el}} &= x \\ \bar{y}_{\text{el}} &= h/2\end{aligned}$$

With vertical strips the variable of integration is x , and the limits on x run from $x = 0$ at the left to $x = b$ on the right. For a rectangle, both 0 and h are constants, but in other situations, \bar{y}_{el} and the left or right limits may be functions of x .

2. *Solve the integrals.*

Substitute dA , \bar{x}_{el} , and \bar{y}_{el} into (7.7.2) and integrate.

$$\begin{aligned}A &= \int dA & Q_x &= \int \bar{y}_{\text{el}} dA & Q_y &= \int \bar{x}_{\text{el}} dA \\ &= \int_0^b h dx & &= \int_0^b \frac{h}{2} (h dx) & &= \int_0^b x (h dx) \\ &= [hx]_0^b & &= \frac{h^2}{2} \int_0^b dx & &= h \int_0^b x dx \\ &= hb - 0 & &= \frac{h^2}{2} [x]_0^b & &= h \left[\frac{x^2}{2} \right]_0^b \\ A &= bh & Q_x &= \frac{h^2 b}{2} & Q_y &= \frac{b^2 h}{2}\end{aligned}$$

Unsurprisingly, we learn that the area of a rectangle is base times height. Since the area formula is well known, it was not really necessary to solve the first integral. Note that A has units of $[\text{length}]^2$, and Q_x and Q_y have units of $[\text{length}]^3$.

3. *Find the centroid.*

Substituting the results into the definitions gives

$$\begin{aligned}\bar{x} &= \frac{Q_y}{A} & \bar{y} &= \frac{Q_x}{A} \\ &= \frac{b^2 h}{2} / bh & &= \frac{h^2 b}{2} / bh \\ &= \frac{b}{2} & &= \frac{h}{2}\end{aligned}$$

Solution 2. This solution demonstrates solving integrals using horizontal rectangular strips. Set the slider on the diagram to $b dy$ to see a representative element.

1. *Set up the integrals.*

The bounding functions $x = 0$, $x = a$, $y = 0$ and $y = h$.

The strip extends from $(0, y)$ on the y axis to (b, y) on the right, and has a differential height dy .

The area of the strip is the base times the height, so

$$dA = b \, dy.$$

The centroid of the strip is located at its midpoint so, by inspection

$$\bar{x}_{\text{el}} = b/2$$

$$\bar{y}_{\text{el}} = y$$

With horizontal strips the variable of integration is y , and the limits on y run from $y = 0$ at the bottom to $y = h$ at the top.

For a rectangle, both 0 and h are constants, but in other situations, \bar{x}_{el} and the upper or lower limits may be functions of y .

2. *Solve the integrals.*

Substitute dA , \bar{x}_{el} , and \bar{y}_{el} into (7.7.2) and integrate. The results are the same as we found using vertical strips.

$$\begin{aligned} A &= \int dA & Q_x &= \int \bar{y}_{\text{el}} \, dA & Q_y &= \int \bar{x}_{\text{el}} \, dA \\ &= \int_0^h b \, dy & &= \int_0^h y (b \, dy) & &= \int_0^h \frac{b}{2} (b \, dy) \\ &= [by]_0^h & &= b \int_0^h y \, dy & &= \frac{b^2}{2} \int_0^h dy \\ &= bh & &= b \left[\frac{y^2}{2} \right]_0^h & &= \frac{b^2}{2} [y]_0^h \\ A = bh & & Q_x &= \frac{h^2 b}{2} & & Q_y = \frac{b^2 h}{2} \end{aligned}$$

3. *Find the centroid.*

Substituting the results into the definitions gives

$$\begin{aligned} \bar{x} &= \frac{Q_y}{A} & \bar{y} &= \frac{Q_x}{A} \\ &= \frac{b^2 h}{2} / bh & &= \frac{h^2 b}{2} / bh \\ &= \frac{b}{2} & &= \frac{h}{2} \end{aligned}$$

Solution 3. This solution demonstrates solving integrals using square elements and double integrals. Set the slider on the diagram to $dx dy$ to see a representative element.

1. *Set up the integrals.*

Set the slider on the diagram to $dx dy$ to see a representative element.

The bounding functions $x = 0$, $x = a$, $y = 0$ and $y = h$.

Instead of strips, the integrals will be evaluated using square elements with width dx and height dy located at (x, y) .

The area of the square element is the base times the height, so

$$dA = dx dy = dy dx.$$

The centroid of the strip is located at its midpoint so, by inspection

$$\bar{x}_{el} = x$$

$$\bar{y}_{el} = y$$

We will integrate twice, first with respect to y and then with respect to x . The limits on the first integral are $y = 0$ to h and $x = 0$ to b on the second. For a rectangle, both b and h are constants. In other situations, the upper or lower limits may be functions of x or y .

2. *Solve the integrals.*

Substitute dA , \bar{x}_{el} , and \bar{y}_{el} into (7.7.2) and integrate the ‘inside’ integral, then the ‘outside’ integral. The results are the same as before.

$$\begin{aligned}
 A &= \int dA & Q_x &= \int \bar{y}_{el} dA & Q_y &= \int \bar{x}_{el} dA \\
 &= \int_0^b \int_0^h dy dx & &= \int_0^b \int_0^h y dy dx & &= \int_0^b \int_0^h x dy dx \\
 &= \int_0^b \left[\int_0^h dy \right] dx & &= \int_0^b \left[\int_0^h y dy \right] dx & &= \int_0^b x \left[\int_0^h dy \right] dx \\
 &= \int_0^b [y]_0^h dx & &= \int_0^b \left[\frac{y^2}{2} \right]_0^h dx & &= \int_0^b x [y]_0^h dx \\
 &= h \int_0^b dx & &= \frac{h^2}{2} \int_0^b dx & &= h \int_0^b x dx \\
 &= h [x]_0^b & &= \frac{h^2}{2} [x]_0^b & &= h \left[\frac{x^2}{2} \right]_0^b \\
 A &= hb & Q_x &= \frac{h^2 b}{2} & Q_y &= \frac{b^2 h}{2}
 \end{aligned}$$

3. Find the centroid.

Substituting the results into the definitions gives

$$\begin{aligned}\bar{x} &= \frac{Q_y}{A} & \bar{y} &= \frac{Q_x}{A} \\ &= \frac{b^2h}{2} / bh & &= \frac{h^2b}{2} / bh \\ &= \frac{b}{2} & &= \frac{h}{2}\end{aligned}$$

Example 7.7.8 Centroid of a triangle.

Use integration to locate the centroid of a triangle with base b and height of h oriented as shown in the interactive.

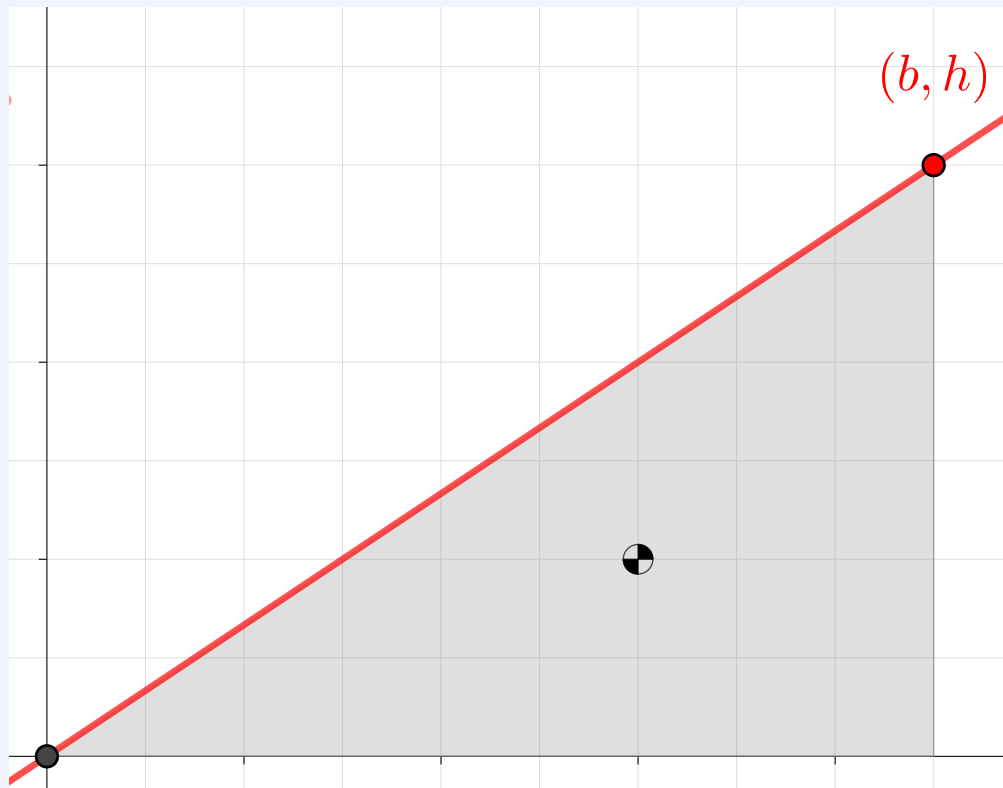

[Live Link](#)

Figure 7.7.9

Solution 1. This solution demonstrates finding the centroid of the triangle using vertical strips $dA = y dx$. Set the slider on the diagram to $y dx$ to see a representative element.

1. *Set up the integrals.*

The bounding functions in this example are the x axis, the vertical line $x = b$, and the straight line through the origin with a slope of $\frac{h}{b}$. Using the slope-intercept form of the equation of a line, the upper bounding function is

$$y = f(x) = \frac{h}{b}x$$

and any point on this line is designated (x, y) .

The strip extends from $(x, 0)$ on the x axis to (x, y) on the function, has a height of y , and a differential width dx . The area of this strip is

$$dA = ydx.$$

The centroid of the strip is located at its midpoint so, by inspection

$$\begin{aligned}\bar{x}_{\text{el}} &= x \\ \bar{y}_{\text{el}} &= y/2\end{aligned}$$

With vertical strips the variable of integration is x , and the limits are $x = 0$ to $x = b$.

2. *Solve the integrals.*

Substitute dA , \bar{x}_{el} , and \bar{y}_{el} into (7.7.2) and integrate. In contrast to the rectangle example both dA and \bar{y}_{el} are functions of x , and will have to be integrated accordingly.

$$\begin{aligned}A &= \int dA & Q_x &= \int \bar{y}_{\text{el}} dA & Q_y &= \int \bar{x}_{\text{el}} dA \\ &= \int_0^b y dx & &= \int_0^b \frac{y}{2}(y dx) & &= \int_0^b x (y dx) \\ &= \int_0^b \frac{h}{b}x dx & &= \frac{1}{2} \int_0^b \left(\frac{h}{b}x\right)^2 dx & &= \int_0^b x \left(\frac{h}{b}x\right) dx \\ &= \frac{h}{b} \left[\frac{x^2}{2}\right]_0^b & &= \frac{h^2}{2b^2} \int_0^b x^2 dx & &= \frac{h}{b} \int_0^b x^2 dx \\ &= \frac{h b^2}{2} & &= \frac{h^2}{2b^2} \left[\frac{x^3}{3}\right]_0^b & &= \frac{h}{b} \left[\frac{x^3}{3}\right]_0^b \\ A &= \frac{bh}{2} & Q_x &= \frac{h^2 b}{6} & Q_y &= \frac{b^2 h}{3}\end{aligned}$$

We learn that the area of a triangle is one half base times height. Since the area formula is well known, it would have been more efficient to skip the first integral. Note that A has units of $[\text{length}]^2$, and Q_x and Q_y have units of $[\text{length}]^3$.

3. *Find the Centroid.*

Substituting the results into the definitions gives

$$\begin{aligned}\bar{x} &= \frac{Q_y}{A} & \bar{y} &= \frac{Q_x}{A} \\ &= \frac{b^2h}{3} \bigg/ \frac{bh}{2} & &= \frac{h^2b}{6} \bigg/ \frac{bh}{2} \\ &= \frac{2}{3}b & &= \frac{1}{3}h\end{aligned}$$

Solution 2. This solution demonstrates solving integrals using horizontal rectangular strips. Set the slider on the diagram to $(b - x) dy$ to see a representative element.

1. *Set up the integrals.*

As before, the triangle is bounded by the x axis, the vertical line $x = b$, and the line

$$y = f(x) = \frac{h}{b}x.$$

To integrate using horizontal strips, the function $f(x)$ must be inverted to express x in terms of y . Solving for $f(x)$ for x gives

$$x = g(y) = \frac{b}{h}y.$$

The limits on the integral are from $y = 0$ to $y = h$.

The strip extends from (x, y) to (b, y) , has a height of dy , and a length of $(b - x)$, therefore the area of this strip is

$$dA = (b - x)dy.$$

The coordinates of the midpoint of the element are

$$\begin{aligned}\bar{y}_{\text{el}} &= y \\ \bar{x}_{\text{el}} &= x + \frac{(b - x)}{2} = \frac{b + x}{2}\end{aligned}$$

These expressions are recognized as the *average* of the x and y coordinates of strip's endpoints.

A common student mistake is to use $dA = x \, dy$, and $\bar{x}_{el} = x/2$. These would be correct if you were looking for the properties of the area to the left of the curve.

2. *Solve the integrals.*

Substitute dA , \bar{x}_{el} , and \bar{y}_{el} into the definitions of Q_x and Q_y and integrate. The results are the same as we found using vertical strips. There is no need to evaluate $A = \int dA$ since we know that $A = \frac{bh}{2}$ for a triangle.

$$\begin{aligned}
 Q_x &= \int \bar{y}_{el} \, dA & Q_y &= \int \bar{x}_{el} \, dA \\
 &= \int_0^h y (b - x) \, dy & &= \int_0^h \frac{(b+x)}{2} (b-x) \, dy \\
 &= \int_0^h (by - xy) \, dy & &= \frac{1}{2} \int_0^h (b^2 - x^2) \, dy \\
 &= \int_0^h \left(by - \frac{by^2}{h} \right) dy & &= \frac{1}{2} \int_0^h \left(b^2 - \frac{b^2 y^2}{h^2} \right) dy \\
 &= b \left[\frac{y^2}{2} - \frac{y^3}{3h} \right]_0^h & &= \frac{b^2}{2} \left[y - \frac{y^3}{3h^2} \right]_0^h \\
 &= bh^2 \left(\frac{1}{2} - \frac{1}{3} \right) & &= \frac{1}{2} (b^2 h) \left(1 - \frac{1}{3} \right) \\
 Q_x &= \frac{h^2 b}{6} & Q_y &= \frac{b^2 h}{3}
 \end{aligned}$$

It makes solving these integrals easier if you avoid prematurely substituting in the function for x and if you factor out constants whenever possible. Here it $x = g(y)$ was not substituted until the fourth line.

3. *Find the centroid.*

Substituting the results into the definitions gives

$$\begin{aligned}
 \bar{x} &= \frac{Q_y}{A} & \bar{y} &= \frac{Q_x}{A} \\
 &= \frac{b^2 h}{3} \bigg/ \frac{bh}{2} & &= \frac{h^2 b}{6} \bigg/ \frac{bh}{2} \\
 &= \frac{2}{3} b & &= \frac{1}{3} h
 \end{aligned}$$

Solution 3. This solution demonstrates solving integrals using square elements and double integrals. Set the slider on the diagram to $dx dy$ or $dy dx$ to see a representative element.

1. *Set up the integrals.*

As before, the triangle is bounded by the x axis, the vertical line $x = b$, and the line

$$y = f(x) = \frac{h}{b}x \quad \text{or in terms of } y, \quad x = g(y) = \frac{b}{h}y.$$

In this solution the integrals will be evaluated using square differential elements $dA = dy dx$ located at (x, y) .

With double integration, you must take care to evaluate the limits correctly, since the limits on the inside integral are functions of the variable of integration of the outside integral. The inside integral essentially stacks the elements into strips and the outside integral adds all the strips to cover the area.

Choosing to express dA as $dy dx$ means that the integral over y will be conducted first. The limits on the inside integral are from $y = 0$ to $y = f(x)$. Then, the limits on the outside integral are from $x = 0$ to $x = b$.

Using $dA = dx dy$ would reverse the order of integration, so the inside integral's limits would be from $x = g(y)$ to $x = b$, and the limits on the outside integral would be $y = 0$ to $y = h$. Either choice will give the same results —*if you don't make any errors!*

The area of the square element is the base times the height, so

$$dA = dy dx.$$

The centroid of the square is located at its midpoint so, by inspection

$$\bar{x}_{\text{el}} = x$$

$$\bar{y}_{\text{el}} = y$$

2. *Solve the integrals.*

Substitute dA , \bar{x}_{el} , and \bar{y}_{el} into (7.7.2) and integrate the ‘inside’ integral, then the ‘outside’ integral. The results are the same as before.

$$Q_x = \int \bar{y}_{\text{el}} dA \qquad Q_y = \int \bar{x}_{\text{el}} dA$$

$$\begin{aligned}
 &= \int_0^b \int_0^{f(x)} y \, dy \, dx & &= \int_0^b \int_0^{f(x)} x \, dy \, dx \\
 &= \int_0^b \left[\int_0^{f(x)} y \, dy \right] dx & &= \int_0^b x \left[\int_0^{f(x)} dy \right] dx \\
 &= \int_0^b \left[\frac{y^2}{2} \right]_0^{f(x)} dx & &= \int_0^b x \left[y \right]_0^{f(x)} dx \\
 &= \frac{1}{2} \int_0^b \left[\frac{h^2}{b^2} x^2 \right] dx & &= \int_0^b x \left[\frac{h}{b} x \right] dx \\
 &= \frac{h^2}{2b^2} \int_0^b x^2 dx & &= \frac{h}{b} \int_0^b x^2 dx \\
 &= \frac{h^2}{2b^2} \left[\frac{x^3}{3} \right]_0^b & &= \frac{h}{b} \left[\frac{x^3}{3} \right]_0^b \\
 Q_x &= \frac{h^2 b}{6} & & Q_y = \frac{b^2 h}{3}
 \end{aligned}$$

3. Find the centroid.

Substituting Q_x and Q_y along with $A = bh/2$ into the centroid definitions gives

$$\begin{aligned}
 \bar{x} &= \frac{Q_y}{A} & \bar{y} &= \frac{Q_x}{A} \\
 &= \frac{b^2 h}{3} \bigg/ \frac{bh}{2} & &= \frac{h^2 b}{6} \bigg/ \frac{bh}{2} \\
 &= \frac{2}{3} b & &= \frac{1}{3} h
 \end{aligned}$$

The next two examples involve areas with functions for both boundaries,

Example 7.7.10 Centroid of a semi-parabola.

Find the coordinates of the centroid of a parabolic spandrel bounded by the y axis, a horizontal line passing through the point (a, b) , and a parabola with a vertex at the origin and passing through the same point. a and b are positive integers.

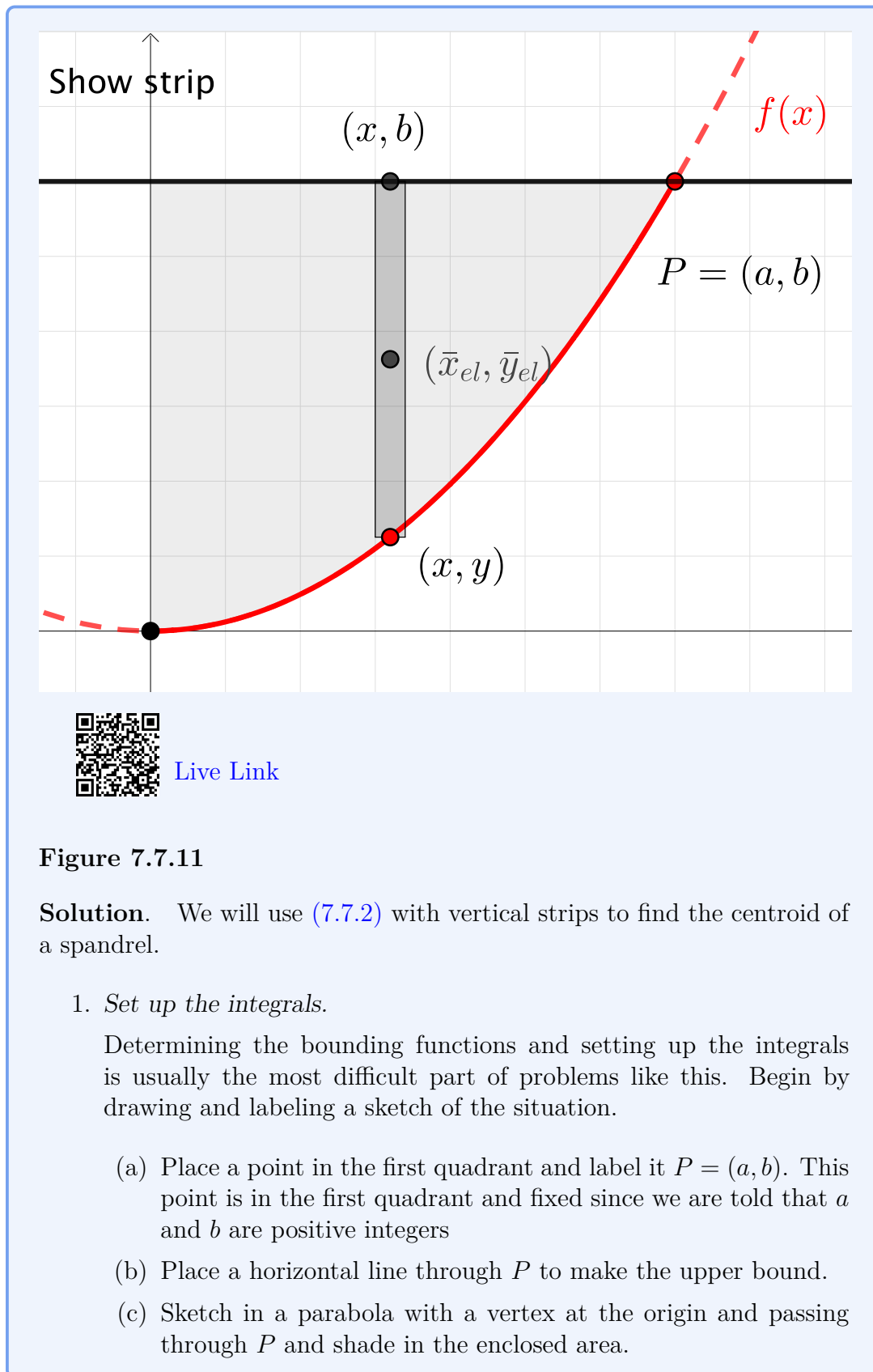

Figure 7.7.11

Solution. We will use (7.7.2) with vertical strips to find the centroid of a spandrel.

1. *Set up the integrals.*

Determining the bounding functions and setting up the integrals is usually the most difficult part of problems like this. Begin by drawing and labeling a sketch of the situation.

- (a) Place a point in the first quadrant and label it $P = (a, b)$. This point is in the first quadrant and fixed since we are told that a and b are positive integers
- (b) Place a horizontal line through P to make the upper bound.
- (c) Sketch in a parabola with a vertex at the origin and passing through P and shade in the enclosed area.

- (d) Decide which differential element you intend to use. For this example we choose to use vertical strips, which you can see if you tick **show strips** in the interactive above. Horizontal strips $dA = x dy$ would give the same result, but you would need to define the equation for the parabola in terms of y .

Determining the equation of the parabola and expressing it in terms of x and any known constants is a critical step. You should remember from algebra that the general equation of parabola with a vertex at the origin is $y = kx^2$, where k is a constant which determines the shape of the parabola. If $k > 0$, the parabola opens upward and if $k < 0$, the parabola opens downward.

To find the value of k , substitute the coordinates of P into the general equation, then solve for k .

$$\begin{aligned}y &= kx^2, \text{ so at } P \\(b) &= k(a)^2 \\k &= \frac{b}{a^2}\end{aligned}$$

The resulting function of the parabola is

$$y = y(x) = \frac{b}{a^2}x^2.$$

To perform the integrations, express the area and centroidal coordinates of the element in terms of the points at the top and bottom of the strip. The area of the strip is its height times its base, so

$$dA = (b - y) dx.$$

If you incorrectly used $dA = y dx$, you would find the centroid of the spandrel below the curve.

For vertical strips, the bottom is at (x, y) on the parabola, and the top is directly above at (x, b) . The strip has a differential width dx . The centroid of the strip is located at its midpoint and the coordinates are found by averaging the x and y coordinates of the points at the top and bottom.

$$\begin{aligned}\bar{x}_{el} &= (x + x)/2 = x \\ \bar{y}_{el} &= (y + b)/2\end{aligned}$$

For vertical strips, the integrations are with respect to x , and the limits on the integrals are $x = 0$ on the left to $x = a$ on the right.

2. Solve the integrals.

We have already established that $y(x) = kx^2$ where $k = b/a^2$. To simplify the algebra, it is best not to prematurely substitute $y(x)$ and k , but you must substitute in any functions of x before you do the integration step.

$$\begin{aligned}
 A &= \int dA & Q_x &= \int \bar{y}_{el} dA & Q_y &= \int \bar{x}_{el} dA \\
 &= \int_0^a (b - y) dx & &= \int_0^a \frac{(b + y)}{2} (b - y) dx & &= \int_0^a x(b - y) dx \\
 &= \int_0^a (b - kx^2) dx & &= \frac{1}{2} \int_0^a (b^2 - y^2) dx & &= \int_0^a x(b - y) dx \\
 &= bx - k \frac{x^3}{3} \Big|_0^a & &= \frac{1}{2} \int_0^a (b^2 - (kx^2)^2) dx & &= \int_0^a x(b - kx^2) dx \\
 &= ba - k \frac{a^3}{3} & &= \frac{1}{2} \int_0^a (b^2 - k^2 x^4) dx & &= \int_0^a (bx - kx^3) dx \\
 &= ba - \left(\frac{b}{a^2}\right) \frac{a^3}{3} & &= \frac{1}{2} \left[b^2 x - k^2 \frac{x^5}{5} \right]_0^a & &= \left[\frac{bx^2}{2} - k \frac{x^4}{4} \right]_0^a \\
 &= \frac{3ba}{3} - \frac{ba}{3} & &= \frac{1}{2} \left[b^2 a - \left(\frac{b}{a^2}\right)^2 \frac{a^5}{5} \right] & &= \left[\frac{ba^2}{2} - \left(\frac{b}{a^2}\right) \frac{a^4}{4} \right] \\
 &= \frac{2}{3} ba & &= \frac{1}{2} b^2 a \left[1 - \frac{1}{5} \right] & &= ba^2 \left[\frac{1}{2} - \frac{1}{4} \right] \\
 A &= \frac{2}{3} ba & Q_x &= \frac{2}{5} b^2 a & Q_y &= \frac{1}{4} ba^2
 \end{aligned}$$

The area of the spandrel is $2/3$ of the area of the enclosing rectangle and the moments of area have units of $[\text{length}]^3$.

3. Find the centroid.

Substituting the results into the definitions gives

$$\begin{aligned}
 \bar{x} &= \frac{Q_y}{A} & \bar{y} &= \frac{Q_x}{A} \\
 &= \frac{ba^2}{4} \Big/ \frac{2ba}{3} & &= \frac{2b^2 a}{5} \Big/ \frac{2ba}{3} \\
 &= \frac{3}{8} a & &= \frac{3}{5} b
 \end{aligned}$$

\bar{x} is $3/8$ of the width and \bar{y} is $3/5$ of the height of the enclosing rectangle.

Example 7.7.12 Centroid of an area between two curves.

Use integration to locate the centroid of the area bounded by

$$y_1 = \frac{x}{4} \text{ and } y_2 = \frac{x^2}{2}.$$

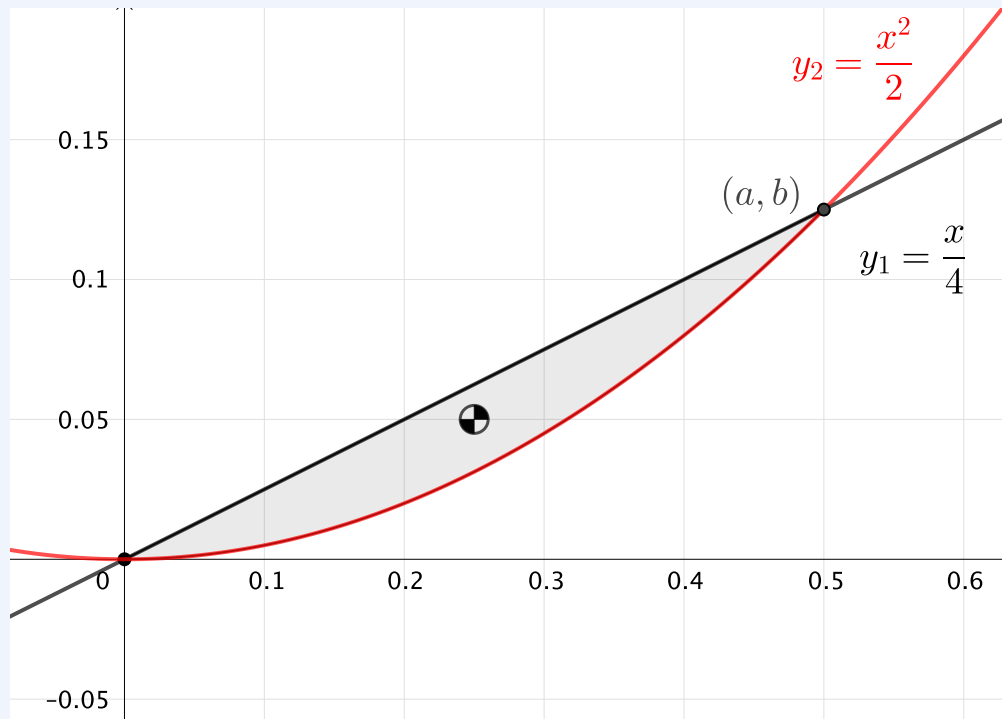

[Live Link](#)

Figure 7.7.13

Find the centroid location (\bar{x}, \bar{y}) of the shaded area between the two curves below.

Solution 1. This solution demonstrates finding the centroid of the area between two functions using vertical strips $dA = y \, dx$. Set the slider on the diagram to $h \, dx$ to see a representative element.

1. *Set up the integrals.*

The bounding functions in this example are the x axis, the vertical line $x = b$, and the straight line through the origin with a slope of $\frac{h}{b}$. Using the slope-intercept form of the equation of a line, the upper bounding function is

$$y = f(x) = \frac{h}{b}x$$

and any point on this line is designated (x, y) .

The strip extends from $(x, 0)$ on the x axis to (x, y) on the function, has a height of y , and a differential width dx . The area of this strip is

$$dA = ydx.$$

The centroid of the strip is located at its midpoint so, by inspection

$$\begin{aligned}\bar{x}_{el} &= x \\ \bar{y}_{el} &= y/2\end{aligned}$$

With vertical strips the variable of integration is x , and the limits are $x = 0$ to $x = b$.

2. *Solve the integrals.*

Substitute dA , \bar{x}_{el} , and \bar{y}_{el} into (7.7.2) and integrate. In contrast to the rectangle example both dA and \bar{y}_{el} are functions of x , and will have to be integrated accordingly.

$$\begin{aligned}A &= \int dA \\ &= \int_0^{1/2} (y_1 - y_2) dx \\ &= \int_0^{1/2} \left(\frac{x}{4} - \frac{x^2}{2} \right) dx \\ &= \left[\frac{x^2}{8} - \frac{x^3}{6} \right]_0^{1/2} \\ &= \left[\frac{1}{32} - \frac{1}{48} \right] \\ A &= \frac{1}{96}\end{aligned}$$

$$\begin{aligned}Q_x &= \int \bar{y}_{el} dA & Q_y &= \int \bar{x}_{el} dA \\ &= \int_0^{1/2} \left(\frac{y_1 + y_2}{2} \right) (y_1 - y_2) dx & &= \int_0^{1/2} x(y_1 - y_2) dx \\ &= \frac{1}{2} \int_0^{1/2} (y_1^2 - y_2^2) dx & &= \int_0^{1/2} x \left(\frac{x}{4} - \frac{x^2}{2} \right) dx \\ &= \frac{1}{2} \int_0^{1/2} \left(\frac{x^2}{16} - \frac{x^4}{4} \right) dx & &= \int_0^{1/2} \left(\frac{x^2}{4} - \frac{x^3}{2} \right) dx \\ &= \frac{1}{2} \left[\frac{x^3}{48} - \frac{x^5}{20} \right]_0^{1/2} & &= \left[\frac{x^3}{12} - \frac{x^4}{8} \right]_0^{1/2}\end{aligned}$$

$$Q_x = \frac{1}{1920} = \frac{1}{2} \left[\frac{1}{384} - \frac{1}{640} \right] \qquad Q_y = \frac{1}{384} = \left[\frac{1}{96} - \frac{1}{128} \right]$$

3. *Find the Centroid.*

Substituting the results into the definitions gives

$$\begin{aligned} \bar{x} &= \frac{Q_y}{A} & \bar{y} &= \frac{Q_x}{A} \\ &= \frac{1}{384} \bigg/ \frac{1}{96} & &= \frac{1}{1920} \bigg/ \frac{1}{96} \\ \bar{x} &= \frac{1}{4} & \bar{y} &= \frac{1}{20} \end{aligned}$$

Solution 2. This solution demonstrates finding the centroid of the area between two functions using vertical strips $dA = y \, dx$. Set the slider on the diagram to $h \, dx$ to see a representative element.

1. *Set up the integrals.*

The bounding functions in this example are the x axis, the vertical line $x = b$, and the straight line through the origin with a slope of $\frac{h}{b}$. Using the slope-intercept form of the equation of a line, the upper bounding function is

$$y = f(x) = \frac{h}{b}x$$

and any point on this line is designated (x, y) .

The strip extends from $(x, 0)$ on the x axis to (x, y) on the function, has a height of y , and a differential width dx . The area of this strip is

$$dA = ydx.$$

The centroid of the strip is located at its midpoint so, by inspection

$$\begin{aligned} \bar{x}_{el} &= x \\ \bar{y}_{el} &= y/2 \end{aligned}$$

With vertical strips the variable of integration is x , and the limits are $x = 0$ to $x = b$.

2. Solve the integrals.

Substitute dA , \bar{x}_{el} , and \bar{y}_{el} into (7.7.2) and integrate. In contrast to the rectangle example both dA and \bar{y}_{el} are functions of x , and will have to be integrated accordingly.

$$\begin{aligned}
 A &= \int dA \\
 &= \int_0^y (x_2 - x_1) dy \\
 &= \int_0^{1/8} (4y - \sqrt{2y}) dy \\
 &= \left[2y^2 - \frac{4}{3}y^{3/2} \right]_0^{1/8} \\
 &= \left[\frac{1}{32} - \frac{1}{48} \right] \\
 A &= \frac{1}{96}
 \end{aligned}$$

$$\begin{aligned}
 Q_x &= \int \bar{y}_{el} dA & Q_y &= \int \bar{x}_{el} dA \\
 &= \int_0^{1/8} y(x_2 - x_1) dy & &= \int_0^{1/8} \left(\frac{x_2 + x_1}{2} \right) (x_2 - x_1) dy \\
 &= \int_0^{1/8} y(\sqrt{2y} - 4y) dy & &= \frac{1}{2} \int_0^{1/8} (x_2^2 - x_1^2) dy \\
 &= \int_0^{1/8} (\sqrt{2}y^{3/2} - 4y^2) dy & &= \frac{1}{2} \int_0^{1/8} (2y - 16y^2) dy \\
 &= \left[\frac{2\sqrt{2}}{5}y^{5/2} - \frac{4}{3}y^3 \right]_0^{1/8} & &= \frac{1}{2} \left[y^2 - \frac{16}{3}y^3 \right]_0^{1/8} \\
 &= \left[\frac{1}{320} - \frac{1}{384} \right] & &= \frac{1}{2} \left[\frac{1}{64} - \frac{1}{96} \right] \\
 Q_x &= \frac{1}{1920} & Q_y &= \frac{1}{384}
 \end{aligned}$$

3. Find the Centroid.

Substituting the results into the definitions gives

$$\begin{aligned}
 \bar{x} &= \frac{Q_y}{A} & \bar{y} &= \frac{Q_x}{A} \\
 &= \frac{1}{384} \bigg/ \frac{1}{96} & &= \frac{1}{1920} \bigg/ \frac{1}{96} \\
 \bar{x} &= \frac{1}{4} & \bar{y} &= \frac{1}{20}
 \end{aligned}$$

The last example demonstrates using double integration with polar coordinates.

Example 7.7.14 Centroid of a semi-circle.

Find the coordinates of the top half of a circle with radius r , centered at the origin.

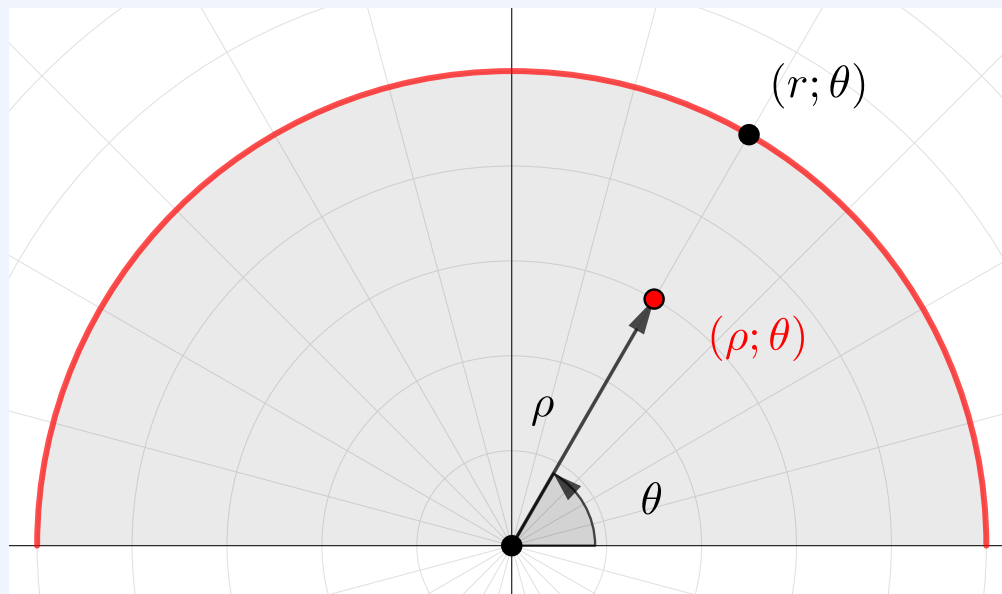

[Live Link](#)

Figure 7.7.15

Solution. We will use (7.7.2) with polar coordinates (ρ, θ) to solve this problem because they are a natural fit for the geometry. In polar coordinates, the equation for the bounding semicircle is simply

$$\rho = r.$$

Normally this involves evaluating three integrals but as you will see, we can take some shortcuts in this problem. Otherwise we will follow the same procedure as before.

1. *Set up the integrals.*

Divide the semi-circle into "rectangular" differential elements of area dA , as shown in the interactive when you select **Show element**. This shape is not really a rectangle, but in the limit as $d\rho$ and $d\theta$ approach zero, it doesn't make any difference.

The radial height of the rectangle is $d\rho$ and the tangential width is the arc length $\rho d\theta$. The product is the differential area dA .

$$dA = (d\rho)(\rho d\theta) = \rho d\rho d\theta. \quad (7.7.3)$$

The differential element is located at (ρ, θ) in polar coordinates. Expressing this point in rectangular coordinates gives

$$\begin{aligned} \bar{x}_{\text{el}} &= \rho \cos \theta \\ \bar{y}_{\text{el}} &= \rho \sin \theta \end{aligned}$$

2. *Solve the integrals.*

The area of a semicircle is well known, so there is no need to actually evaluate $A = \int dA$,

$$A = \int dA = \frac{\pi r^2}{2}.$$

Since the semi-circle is symmetrical about the y axis,

$$Q_y = \int \bar{x}_{\text{el}} dA = 0.$$

This is because each element of area to the right of the y axis is balanced by a corresponding element the same distance the left which cancel each other out in the sum.

All that remains is to evaluate the integral Q_x in the numerator of

$$\bar{y} = \frac{Q_x}{A} = \frac{\int \bar{y}_{\text{el}} dA}{A}$$

The differential area dA is the product of two differential quantities, we will need to perform a double integration.

$$\begin{aligned} Q_x &= \int \bar{y}_{\text{el}} dA \\ &= \int_0^\pi \int_0^r (\rho \sin \theta) \rho d\rho d\theta \\ &= \int_0^\pi \sin \theta \left[\int_0^r \rho^2 d\rho \right] d\theta \\ &= \int_0^\pi \sin \theta \left[\frac{\rho^3}{3} \right]_0^r d\theta \\ &= \frac{r^3}{3} \int_0^\pi \sin \theta d\theta \end{aligned}$$

$$\begin{aligned}
 &= \frac{r^3}{3} [-\cos \theta]_0^\pi \\
 &= -\frac{r^3}{3} [\cos \pi - \cos 0] \\
 &= -\frac{r^3}{3} [(-1) - (1)] \\
 Q_x &= \frac{2}{3}r^3
 \end{aligned}$$

3. Find the centroid.

Substituting the results into the definitions gives

$$\begin{aligned}
 \bar{y} &= \frac{Q_x}{A} \\
 &= \frac{2r^3}{3} \bigg/ \frac{\pi r^2}{2} \\
 &= \frac{4r}{3\pi}
 \end{aligned}$$

So $\bar{x} = 0$ and lies on the axis of symmetry, and $\bar{y} = \frac{4r}{3\pi}$ above the diameter.

This result can be extended by noting that a semi-circle is mirrored quarter-circles on either side of the y axis. These must have the same \bar{y} value as the semi-circle. Further, quarter-circles are symmetric about a 45° line, so for the quarter-circle in the first quadrant,

$$\bar{x} = \bar{y} = \frac{4r}{3\pi}.$$

7.8 Distributed Loads

Key Questions

- What is a distributed load?
- Given a distributed load, how do we find the magnitude of the equivalent concentrated force?
- Given a distributed load, how do we find the location of the equivalent concentrated force?

Distributed loads are forces which are spread out over a length, area, or

volume. Most real-world loads are distributed, including the weight of building materials and the force of wind, water, or earth pushing on a surface. Pressure, load, weight density and stress are all names commonly used for distributed loads. Distributed load is a force per unit length or force per unit area depicted with a series of force vectors joined together at the top, and will be designated as $w(x)$ to indicate that the distributed loading is a function of x .

For example, although a shelf of books *could* be treated as a collection of individual forces, it is more common and convenient to represent the weight of the books as a **uniformly distributed load**. A uniformly distributed load is a load which has the same value everywhere, i.e. $w(x) = C$, a constant.



(a) A shelf of books with various weights.

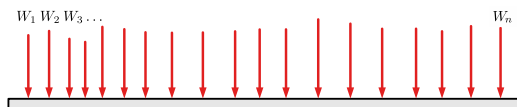

(b) Each book represented as an individual weight

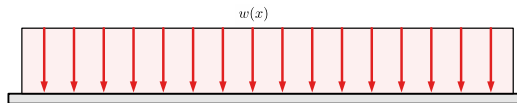

(c) All the books represented as a distributed load.

Figure 7.8.1

We can use the computational tools discussed in the previous chapters to handle distributed loads if we first convert them to equivalent point forces. This equivalent replacement must be the **resultant** of the distributed loading, as discussed in [Section 4.7](#). Recall that this resultant force has the same external effect on the object as the original system of forces did.

To be equivalent, the point force must have a:

- Magnitude equal to the area or volume under the distributed load function.
- Line of action that passes through the centroid of the distributed load distribution.

The next two sections will explore how to find the magnitude and location of the equivalent point force for a distributed load.

7.8.1 Equivalent Magnitude

The magnitude of the distributed load of the books is the total weight of the books divided by the length of the shelf

$$w(x) = \frac{\Sigma W_i}{\ell}.$$

It represents the *average* book weight per unit length. Similarly, the total weight of the books is equal to the value of the distributed load times the length of the shelf or

$$W = w(x)\ell$$

$$\text{total weight} = \frac{\text{weight}}{\text{length}} \times \text{length of shelf}$$

This total load is simply the area under the curve $w(x)$, and has units of force. If the loading function is not uniform, integration may be necessary to find the area.

Example 7.8.2 Bookshelf.

A common paperback is about 3 cm thick and weighs approximately 3 N. What is the loading function $w(x)$ for a shelf full of paperbacks and what is the total weight of paperback books on a 6 m shelf?

Solution. The weight of one paperback over its thickness is the load intensity $w(x)$, so

$$w(x) = \frac{3 \text{ N}}{3 \text{ cm}} = 100 \text{ N/m}.$$

The total weight is the area under the load intensity diagram, which in this case is a rectangle. So, a 6 m bookshelf covered with paperbacks would have to support

$$W = w(x)\ell = (100 \text{ N/m})(6 \text{ m}) = 600 \text{ N}.$$

The line of action of this equivalent load passes through the centroid of the rectangular loading, so it acts at $x = 3 \text{ m}$.

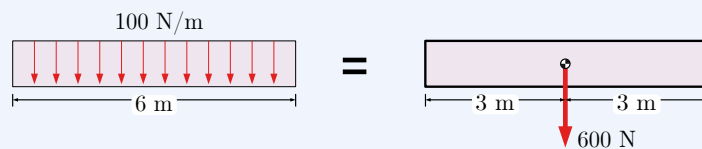

7.8.2 Equivalent Location

To use a distributed load in an equilibrium problem, you must know the equivalent magnitude to sum the forces, and also know the position or line of action to sum the moments.

The line of action of the equivalent force acts through the centroid of area under the load intensity curve. For a rectangular loading, the centroid is in the center. We know the vertical and horizontal coordinates of this centroid, but since the equivalent point force's line of action is vertical and we can slide a force along its line of action, the vertical coordinate of the centroid is not important in this context.

Similarly, for a triangular distributed load — also called a **uniformly varying load**— the magnitude of the equivalent force is the area of the triangle, $bh/2$ and the line of action passes through the centroid of the triangle. The horizontal distance from the larger end of the triangle to the centroid is $\bar{x} = b/3$.

Essentially, we're finding the balance point so that the moment of the force to the left of the centroid is the same as the moment of the force to the right.

The examples below will illustrate how you can combine the computation of both the magnitude and location of the equivalent point force for a series of distributed loads.

Example 7.8.3 Uniformly Varying Load.

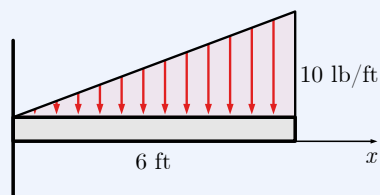

Find the equivalent point force and its point of application for the distributed load shown.

Solution. The equivalent load is the ‘area’ under the triangular load intensity curve and it acts straight down at the centroid of the triangle. This triangular loading has a 6 ft base and a 10 lb/ft height so

$$W = \frac{1}{2}bh = \frac{1}{2}(6 \text{ ft})(10 \text{ lb/ft}) = 30 \text{ lb.}$$

and the centroid is located $2/3$ of the way from the left end so,

$$\bar{x} = 4 \text{ ft.}$$

Distributed loads may be any geometric shape or defined by a mathematical function. If the load is a combination of common shapes, use the properties of the shapes to find the magnitude and location of the equivalent point force using the methods of [Section 7.5](#). If the distributed load is defined by a mathematical function, integrate to find their area using the methods of [Section 7.7](#).

A few things to note:

- You can include the distributed load or the equivalent point force on your free-body diagram, *but not both!*
- Since you're calculating an area, you can divide the area up into any shapes you find convenient. So, if you don't recall the area of a trapezoid off the

top of your head, break it up into a rectangle and a triangle.

7.8.3 Distributed Load Applications

Once you convert distributed loads to the resultant point force, you can solve problem in the same manner that you have other problems in previous chapters of this book. Note that while the resultant forces are *externally* equivalent to the distributed loads, they are not *internally* equivalent, as will be shown [Chapter 8](#).

Example 7.8.4 Cantilever Beam.

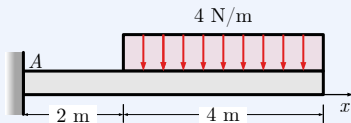

Find the reactions at the fixed connection at A .

Solution. Draw a free-body diagram with the distributed load replaced with an equivalent concentrated load, then apply the equations of equilibrium.

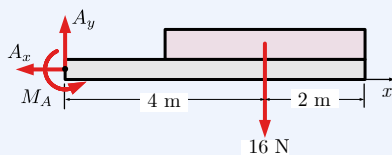

$$\begin{aligned}\Sigma F_x = 0 &\rightarrow A_x = 0 \\ \Sigma F_y = 0 &\rightarrow A_y = 16 \text{ N} \\ \Sigma M_A = 0 &\rightarrow M_A = (16 \text{ N})(4 \text{ m}) \\ &= 64 \text{ N}\cdot\text{m}\end{aligned}$$

Example 7.8.5 Beam Reactions.

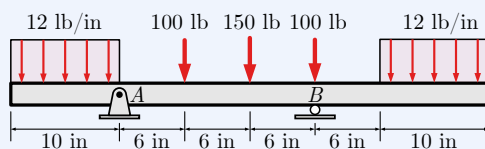

Find the reactions at the supports for the beam shown.

Solution. Start by drawing a free-body diagram of the beam with the two distributed loads replaced with equivalent concentrated loads. The two distributed loads are $(10 \text{ in})(12 \text{ lb/in}) = 120 \text{ lb}$ each.

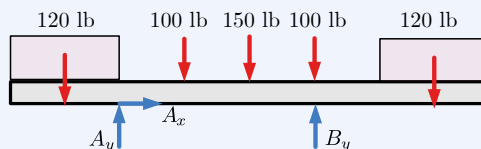

Then apply the equations of equilibrium.

$$\begin{aligned}\Sigma M_A = 0 \\ +(12 \text{ lb/in})(10 \text{ in})(5 \text{ in}) - (100 \text{ lb})(6 \text{ in})\end{aligned}$$

$$\begin{aligned}
 & -(150 \text{ lb})(12 \text{ in}) - (100 \text{ lb})(18 \text{ in}) \\
 & +(B_y)(18 \text{ in}) - (12 \text{ lb/in})(10 \text{ in})(29 \text{ in}) = 0 \rightarrow B_y = 393.3 \text{ lb}
 \end{aligned}$$

$$\begin{aligned}
 & \sum F_y = 0 \\
 & -(12 \text{ lb/in})(10 \text{ in}) + A_y - 100 \text{ lb} - 150 \text{ lb} \\
 & -100 \text{ lb} + B_y - (12 \text{ lb/in})(10 \text{ in}) = 0 \rightarrow A_y = 196.7 \text{ lb}
 \end{aligned}$$

$$\sum F_x = 0 \rightarrow A_x = 0$$

7.9 Fluid Statics

Key Questions

- What is the basic relationship between depth and pressure?
- How are absolute and relative pressure different?
- How can use our knowledge of centroids to compute the equivalent point forces of fluids?

Pressure is the term used for a force distributed over an area

$$P = \frac{F}{A}. \quad (7.9.1)$$

We will consider the effect of fluid pressure on underwater surfaces, including slanted or curved objects. In all cases we will simply ask the question: what is the pressure at each point and how does it change along the surface?

Pressure can be measured in two different ways

- **Absolute pressure** is the pressure measured above an absolute or perfect vacuum. The absolute pressure of the surrounding atmosphere is approximately 101.3 kPa or 14.7 lb/in², and a perfect vacuum is 0 psi or 0 kPa.
- **Gage pressure** is the pressure indicated by a standard pressure gage. The gage reads zero when exposed directly to the atmosphere, positive when the pressure is higher than atmospheric pressure, and negative pressure indicates a vacuum. In effect, pressure gages ignores the pressure of the atmosphere which surrounds us.

We will use gage pressure for the remainder of the chapter.

Commonly used pressure units include:

- 1 pascals (Pa) = 1 N/m²

- 1 kilopascal (kPa) = 1000 N/m²
- 1 pound per square inch (psi) = lb/in²
- 1 kip per square inch (ksi) = 1000 lb/in²
- 1 pound per square foot (psf) = 1 lb/ft²

7.9.1 Principles of Fluid Statics

A fluid, like water or air exerts a pressure on its surroundings. This pressure applies a distributed load on surfaces surrounding the fluid, like the face of a dam, an irrigation control gate, a teakettle, or the drum of a steam boiler.

When you dive underwater, the pressure you feel in your ears increases with depth. At the surface, the gage pressure is zero no matter which unit system you use. As you descend, the fluid pressure P increases with depth according to the equation

$$P = \rho gh, \quad (7.9.2)$$

where:

- ρ is the density of a fluid,
- g is gravitational acceleration, and
- h is the height of fluid above the point of interest.

Since fluid pressure increases linearly with depth, it behaves as a distributed load which increases linearly from 0 at the surface to ρgh at depth h , acting normal to the surface. The pressure can be replaced with an equivalent force acting through the centroid of the triangular loading, with a magnitude equal to the triangular area. The pressure on horizontal surfaces is constant, and it is normal to all surfaces.

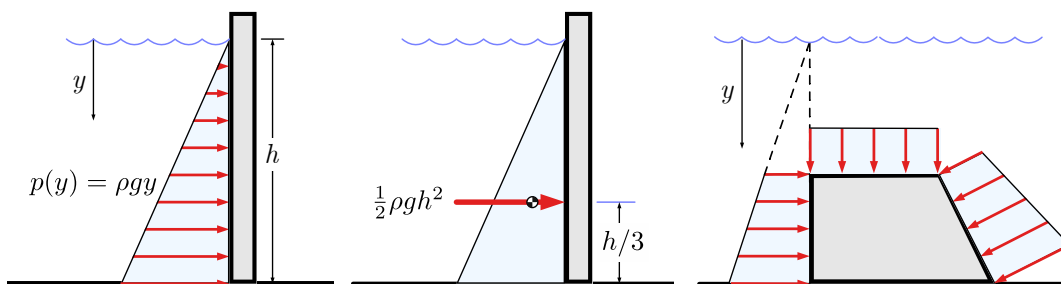

(a) Distributed pressure. (b) Equivalent force. (c) Pressure is perpendicular to the surface.

Figure 7.9.1 Pressure on submerged surfaces.

Some points to remember when solving fluid pressure problems.

1. The pressure due to the fluid always acts perpendicular the surface.
2. A particle underwater will feel the same pressure from all directions.
3. Pressure increases linearly with depth. $P = \rho gh$
4. $P = \rho gh$ assumes a constant density and thus is valid only for incompressible fluids like water or oil, but not for compressible fluids like air.
5. In English units, specific weight γ is often used instead of density ρ to describe fluids. Specific weight is the *weight* per unit volume of a substance, while density is its *mass* per unit volume. The two properties are related by $\gamma = \rho g$. The specific weight of freshwater at room temperature is about 62.4 lb/ft^3 .
6. Gage pressure is the pressure above the surrounding atmospheric pressure. Atmospheric pressure is approximately 14.7 lb/in^2 or 101.3 kPa , but since this pressure acts on everything equally and from all directions, the pressure scale can be offset to make the pressure of the surroundings 0 lb/in^2 , gage.

Question 7.9.2

Does fluid pressure depend on the surface area of the container? For instance, is the pressure below the Atlantic Ocean less than the pressure below the Pacific Ocean since the Pacific is larger?

Answer. No. Fluid pressure is a function of density and depth only, so the surface area of an ocean or tank is insignificant.

$$P = \rho gh.$$

Assuming that the density of seawater and g are the same everywhere under the ocean, the gage pressure depends on depth only.

Question 7.9.3

Compare the pressure at three feet and thirty feet below the surface of freshwater to the atmospheric pressure.

Answer. The gage pressure at 3 ft is

$$p = \gamma d = 62.4 \text{ lb/ft}^3 \times 3 \text{ ft} = 187 \text{ lb/ft}^2 = 1.30 \text{ lb/in}^2.$$

This is

$$\frac{14.7 \text{ lb/in}^2 + 1.3 \text{ lb/in}^2}{14.7 \text{ lb/in}^2} = 1.088,$$

approximately 9% greater than atmospheric pressure.

At 30 ft below the surface, the pressure is 10 times higher, 13.0 lb/in^2 which is nearly twice atmospheric pressure.

7.9.2 Fluid Statics Applications

Example 7.9.4 Force on a submerged window.

An aquarium tank has a $3 \text{ m} \times 1.5 \text{ m}$ window AB for viewing the inhabitants. The tank contains water with density $\rho = 1000 \text{ kg/m}^3$.

Find the force of the water on the window, and the location of the equivalent point load.

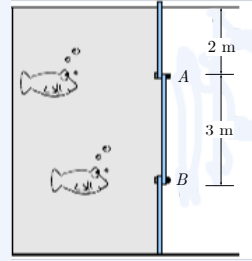

Solution. Begin by drawing a diagram of the window showing the load intensity and the equivalent concentrated force.

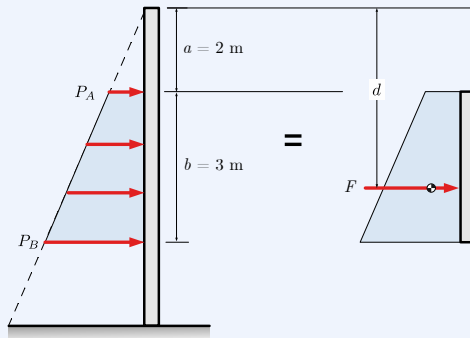

The pressure at the top and the bottom of the window are

$$P_A = \rho g(2 \text{ m}) = 19620 \text{ N/m}^2$$

$$P_B = \rho g(5 \text{ m}) = 49050 \text{ N/m}^2$$

Since the loading is linear, the average pressure acting on the window is

$$P_{ave} = (P_A + P_B)/2$$

$$= 34300 \text{ N/m}^2$$

The total force acting on the window is the average pressure times the area of the window

$$F = (P_{ave})(3 \text{ m} \times 1.5 \text{ m})$$

$$= 155 \text{ kN}$$

This force may also be visualized as the volume of a trapezoidal prism with a 1.5 m depth into the page.

The line of action of the equivalent force passes through the centroid of the trapezoid, which may be calculated using composite areas, see [Section 7.5](#).

Dividing the trapezoid into a triangle and a rectangle and measuring down from the surface of the tank, the distance to the equivalent force is

$$d = \frac{\sum A_i \bar{y}_i}{\sum A_i}$$

$$d = \frac{[P_A(3 \text{ m})](3.5 \text{ m}) + \left[\frac{1}{2}(P_B - P_A)(3 \text{ m}) \right](4 \text{ m})}{[P_A(3 \text{ m})] + \left[\frac{1}{2}(P_B - P_A)(3 \text{ m}) \right]}$$

$$d = 3.71 \text{ m}$$

If you prefer, you may use the formula from the [Centroid table](#) to locate the centroid of the trapezoid instead.

Example 7.9.5 Mud on Concrete Wall.

A concrete retaining wall 3 m tall and 0.8 m thick encloses wet clay mud.

Find the maximum depth h of mud that can be retained without tipping the wall.

Assume the density of mud is 1760 kg/m^3 and the density of concrete is 2400 kg/m^3 .

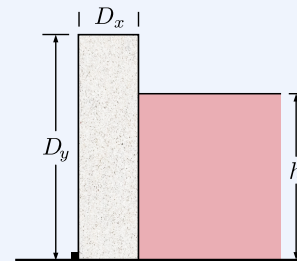

Solution. Begin by drawing free-body diagram of the wall, showing the forces acting on it: the weight of the concrete W_c , acting at the center of gravity of the rectangular wall, the horizontal force F due to the mud, and the reaction components at A . Define symbol D_z for the unspecified length of the wall into the page.

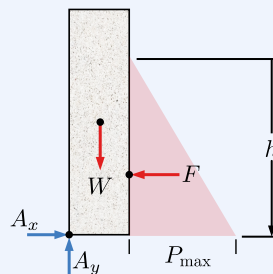

The weight of the concrete is found by multiplying the weight density of concrete $\lambda_c = \rho_c g$ by the volume of the rectangular wall.

$$W_c = \lambda_c V$$

$$= (\rho_c g) (D_x D_y D_z)$$

The horizontal force is caused by the hydraulic pressure of the mud on

the submerged face of the wall. The pressure is a distributed load that increases linearly from zero at the surface to $P_{\max} = \rho_m g h$ at depth h . Since the loading is triangular, the average pressure is one-half the maximum pressure, and the resulting force is:

$$\begin{aligned} F &= P_{\text{ave}}A = \frac{1}{2}P_{\max}A \\ &= \frac{1}{2}(\rho_m g h)(hD_z) \end{aligned}$$

The wall will tip if the counter-clockwise moment due to F is greater than the clockwise moment caused by the concrete's weight. By taking moments about point A , we can find the maximum allowable height of the mud, h . Note that the length of the dam and g appear on both sides and cancel out.

$$\begin{aligned} \Sigma M_A &= 0 \\ (W_c) \left(\frac{D_x}{2} \right) &= F \left(\frac{h}{3} \right) \\ (\rho_c \cancel{g} D_x D_y \cancel{D_z}) \left(\frac{D_x}{2} \right) &= \left(\frac{1}{2} \rho_m \cancel{g} h^2 \cancel{D_z} \right) \left(\frac{h}{3} \right) \\ h^3 &= 3 \frac{\rho_c}{\rho_m} D_x^2 D_y \\ h^3 &= 3 \frac{2400 \text{ kg/m}^3}{1760 \text{ kg/m}^3} (0.8 \text{ m})^2 (3.0 \text{ m}) \\ h &= 1.98 \text{ m} \end{aligned}$$

Example 7.9.6 Sea Gate.

A sea gate is hinged at point A and is designed to rotate and release the water when the depth d exceeds a certain value.

The gate extends 2 m into the page. The mass density of the water is $\rho = 1000 \text{ kg/m}^3$.

What depth will cause the gate to open?

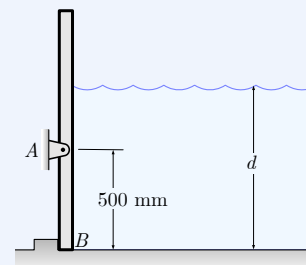

Solution. For the gate to tip, the equivalent force of the water must act at or above A . That happens when the centroid of the load intensity diagram of the water is at or above A , so

$$\begin{aligned} \frac{d}{3} &\geq 500 \text{ mm} \\ d &\geq 1500 \text{ mm} \end{aligned}$$

Example 7.9.7 Gate with Horizontal Surface.

A gate at the end of a freshwater channel is fabricated from three 125 kg, $0.6 \text{ m} \times 1 \text{ m}$ rectangular steel plates. The gate is hinged at A and rests against a frictionless support at D . The depth of the water d is 0.75 m .

Draw the free-body diagram and determine the reactions at A and D .

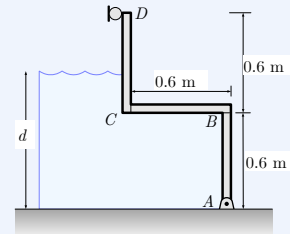

Solution.

A free-body diagram of a cross section of the gate is shown. For simplicity the thickness of the steel plates has been ignored. You should ensure that sufficient distances are provided to locate the loads.

The easiest way to solve this is to apply the principle of transmissibility: slide the lower trapezoid left until it aligns with the upper triangle and makes a triangular loading.

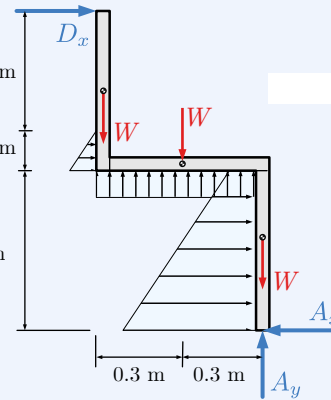

The total horizontal force from the water will be

$$\begin{aligned}
 F_x &= P_{ave} A \\
 &= \left[\frac{1}{2} \rho g 0.75 \text{ m} \right] (0.75 \text{ m} \times 1 \text{ m}) \\
 &= \left[\frac{1}{2} (1000 \text{ kg/m}^3) (9.81 \text{ m/s}^2) 0.75 \text{ m} \right] (0.75 \text{ m} \times 1 \text{ m}) \\
 &= 2760 \text{ N}
 \end{aligned}$$

acting to the right 0.25 m above point A .

The total vertical load from the water is

$$\begin{aligned}
 F_y &= P_{ave} A \\
 &= [\rho g (0.15 \text{ m})] (0.6 \text{ m} \times 1 \text{ m}) \\
 &= [(1000 \text{ kg/m}^3) (9.81 \text{ m/s}^2) (0.15 \text{ m})] (0.6 \text{ m} \times 1 \text{ m}) \\
 &= 882.9 \text{ N}
 \end{aligned}$$

acting upward 0.3 m to the left of A .

Each plate weighs

$$W = mg$$

$$\begin{aligned} &= (125 \text{ kg})(9.81 \text{ m/s}^2) \\ &= 1226 \text{ N} \end{aligned}$$

From here solve the equilibrium equations to find the reactions. You should complete this for practice.

$$\begin{array}{lll} \Sigma M_A = 0 & \implies & D_x = 239 \text{ N } \rightarrow \\ \Sigma F_x = 0 & \implies & A_x = 2998 \text{ N } \leftarrow \\ \Sigma F_y = 0 & \implies & A_y = 2795 \text{ N } \uparrow \end{array}$$

7.10 Exercises (Ch. 7)

Chapter 7 Exercises

Centroids by Composite Area	0/110
Centroid of parts	0/30
	Not attempted
Shape with Hole	0/40
	Not attempted
Rectangles and Triangles	0/40
	Not attempted
Centroids by Integration	0/130
Differential Elements	0/30
	Not attempted
Area under a curve	0/20
	Not attempted
Centroids by integration	0/60
	Not attempted
Upper and lower bounds are functions	0/20
	Not attempted
Distributed Loads	0/60
Uniformly distributed load	0/20
	Not attempted
Uniformly varying load	0/20
	Not attempted
Trapezoidal loading	0/20
	Not attempted

Display options

Done

Created using [Numbas](#) v9.1, developed by [Newcastle University](#).



Standalone
In Context

Chapter 8

Internal Forces

One of the fundamental assumptions we make in statics is that bodies are *rigid*, that is, they do not deform, bend, or change shape. While we know that this assumption is not true for real materials, we are building the analytical tools necessary to analyze deformation. In this chapter you will learn to compute the forces and moments inside a object which hold it together as it supports its own weight and any applied loads.

The chapter begins with a discussion of internal forces and moments and defines a new sign conventions especially for them. Next we will determine internal forces at a specific point within a rigid body. Finally, we develop three techniques to find internal forces at every point throughout a beam. Note that we use the words **internal forces** when we are referring to both “internal forces and internal bending moments.”

Determination of the internal forces is the first step in the engineering design of a structure. A properly designed structure must safely support all expected external loads, including live loads, dead loads, wind and earthquake loads. External loads produce internal forces, which in turn creates stresses, strains, and deformations in the structure. In a successful design, the shape, size, and material must all be carefully chosen to limit them to safe values. You are advised to pay attention, and master this topic.

8.1 Internal Forces

In [Subsection 3.3.3](#) you were introduced to axial loadings, which were either tension or compression, or possibly zero. This section will explain two other internal forces found in two-dimensional systems, the **internalshear** and **internalbending moment**.

Internal forces are present at every point within a rigid body, but they always occur in equal-and-opposite pairs which cancel each other out, so they’re not obvious. They’re there however, and when an object is cut (in your imagination) into two parts the internal forces become visible and can be determined.

You are familiar with straight, two-force members which only exist in equilibrium if equal and opposite forces act on either end. Now imagine that we cut the member at some point along its length. To maintain equilibrium, forces must exist at the cut, equal and opposite to the external forces. These forces are internal forces.

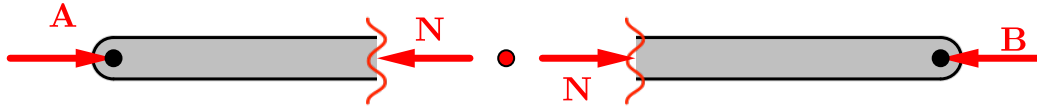

[Live Link](#)

Figure 8.1.1 Internal forces in a straight two-force member.

Now let's examine the two-force member shown in [Figure 8.1.2](#). This time, the member is L shaped, not straight, but the external forces must still share the same line of action to maintain equilibrium. If you cut across the object, you will obtain two rigid bodies which must also be in equilibrium. However, adding an equal and opposite horizontal force at the cut won't produce static equilibrium because the two forces form a couple which causes the piece to rotate. This means that something is missing!

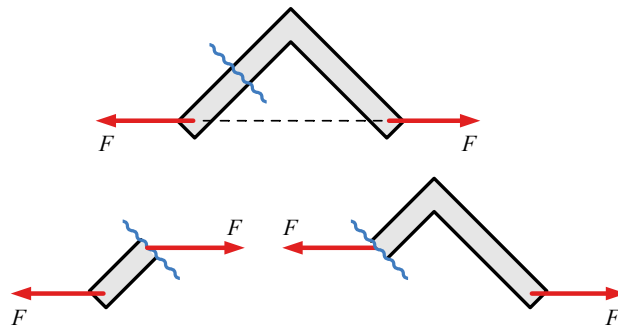

Figure 8.1.2 A horizontal force alone does not create equilibrium.

Two-dimensional rigid bodies have three degrees-of-freedom and require three equilibrium equations to satisfy static equilibrium in order to prevent translation in the x direction, the y direction, and to prevent rotation about the z axis.

Assuming the material is rigid, the connection between the two halves must resist both translation and rotation, so we can model this connection as a fixed support and replace the removed half of the link with a force reaction *and* a couple-moment reaction as shown in the free-body diagrams of [Figure 8.1.3](#). This internal loading is actually a simplification of a more complex loading distributed across the section plane. The couple \mathbf{M} represents the net rotational effect of the force system on the surface of the cut.

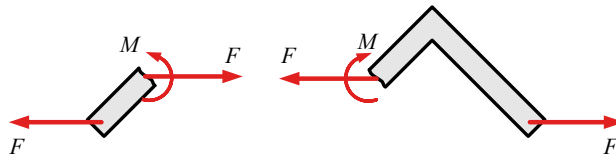

Figure 8.1.3 The internal forces are represented as an equal and opposite force \mathbf{F} and a bending moment \mathbf{M}

The horizontal force can also be resolved into orthogonal components parallel and perpendicular to the cut. These components have special names in the context of internal forces.

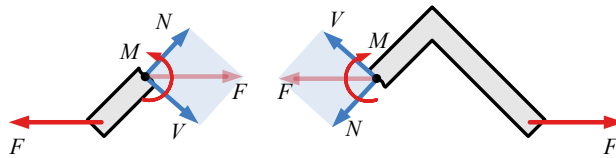

Figure 8.1.4 The internal forces are represented as a normal force \mathbf{N} , a shear force \mathbf{V} , and bending moment \mathbf{M}

The internal force component perpendicular to the cut is called the **normal force**. This is the same internal tension or compression force that we assumed to be the only significant internal load for trusses. If the object has an axis, and the cut is perpendicular to it, the normal force may also be properly called an **axial force**.

The internal force component parallel to the cut is called the **shear force**. The word shear refers to the shearing that occurs between adjacent planes due to this force. You can get a feel for shearing adjacent planes by sliding two pieces of paper together.

The internal couple-moment is called the **bending moment** because it tends to bend the material by rotating the cut surface.

The shear force is often simply referred to as **shear**, and the bending moment as **moment**; together with the normal or axial force the three together are referred to as the “internal forces”. The symbol \mathbf{V} is commonly chosen for the shear force, and \mathbf{A} , \mathbf{P} or \mathbf{N} for the normal force and \mathbf{M} for the bending moment.

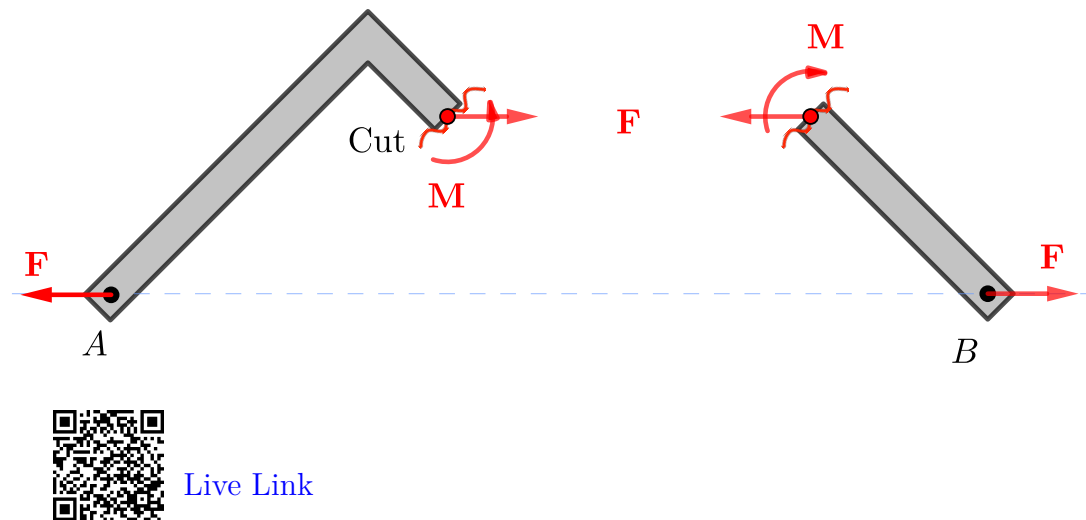

[Live Link](#)

Figure 8.1.5 Internal Loading in a L shaped member.

Thinking Deeper 8.1.6 Deformation.

The controlling design parameter for most engineering systems is deformation. Thankfully, due to a property called elasticity, most materials will bend, stretch, and compress, long before they ultimately break. For example, when designing the floor in a new building, the floor is often limited to deflecting less than the length of the span in inches, divided by 360. Any more deformation than this would be considered disconcerting to the building residents and also start damaging surface materials like drywall. For example, for a 20 ft span, the deflection would need to be less than

$$\delta = \frac{20 \text{ ft} \cdot \frac{12 \text{ in}}{1 \text{ ft}}}{360} = 0.667 \text{ in.}$$

To meet this deformation limit, we need to consider the magnitude and location of applied loads, the size and shape of the floor beams, and the material the floor beams are made from. As deflection is an internal property of the flooring materials, the first step is to determine the internal forces that arise from the externally applied loads, using the methods of this chapter.

8.2 Sign Conventions

When talking about internal forces our standard sign convention for forces and moments is not good enough. We can't, for instance, just call a vertical shear force positive if it points up and negative if it points down, because internal

forces always occur in pairs so at any given point a shear force is both up *and* down. The direction of the internal force at a point depends on which side of the cut you're looking at.

So to define the state of internal forces at a point we need a better sign convention. Although the choice is somewhat arbitrary, agreeing on a *standard* sign convention allows us to have consistency across our calculations and to communicate the internal state clearly to others. The standard sign conventions defined here are used for internal loadings at a point and also for the shear and bending moment diagrams which are discussed in [Section 8.4](#).

Be aware that although this new sign convention applies to internal forces, it doesn't change the sign convention for the equations of equilibrium at all, so you will continue to solve them in the same way you always have.

The standard sign convention used for shear force, normal force, and bending moment is shown below.

- *Positive Shear.*



Positive shear forces tend to skew an object as shown, i.e. positive shear forces push down when looking from the right, and up when looking from the left.

- *Positive Normal Force.*

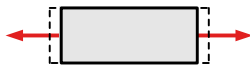

Positive normal forces tend to stretch the object.

- *Positive Bending Moment.*



Positive bending moments tend to deform the object with an upward curvature.

Question 8.2.1

We have defined positive internal forces by looking at the “front” side of the object. Would the results change if you walked around the object and analyzed it from the other side?

8.3 Internal Forces at a Point

This section covers the procedure to compute the internal normal force, shear force, and bending moment at a designated point in a multi-force rigid body.

Consider the frame shown in [Figure 8.3.1](#) consisting of two-force members GD and BE , and multi-force members AD and CF . Since no information is provided, we can assume that the components have negligible weight. The internal loading within the two-force members is purely axial, but the multi-force members will be subject to the complete set of shear force, normal force, and bending moment.

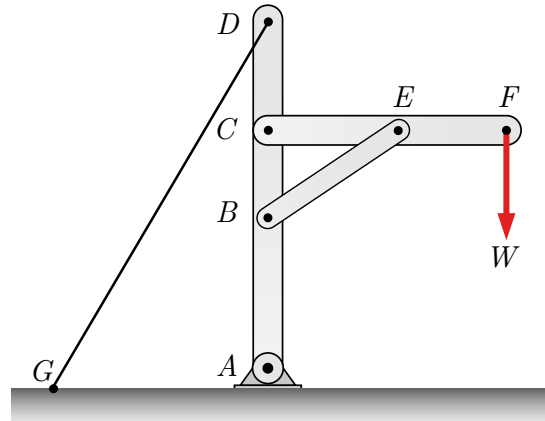
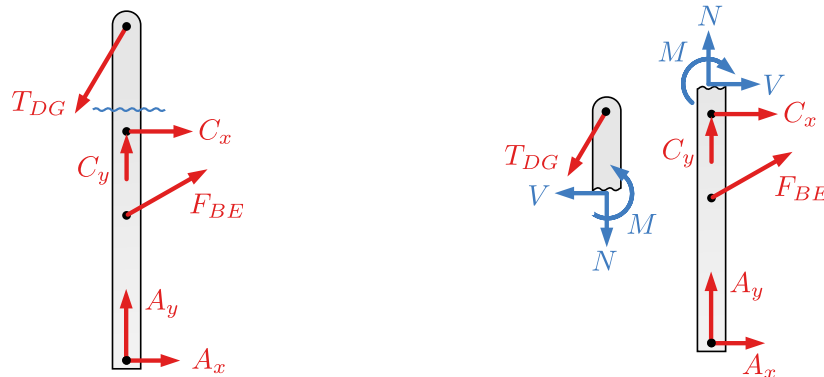

Figure 8.3.1 A frame supporting a load at F .

To find the internal forces at a specified point within one of the members, we make an imaginary cut there.



(a) Wavy line indicates the location of the imaginary cut.

(b) Internal forces are exposed by the cut.

Figure 8.3.2

[Figure 8.3.2\(a\)](#) shows the free-body diagram of member AD , with a proposed cut between points D and C . The free-body diagram is shown with reactions for pinned connections at A and C and forces from the two-force members at locations B and D .

[Figure 8.3.2\(b\)](#) shows the free-body diagrams for each half, with the three internal forces exposed and labeled V , N , and M . This is analogous to the Method of Sections technique of [Chapter 6](#).

Note that the internal forces at the cut are drawn in the positive direction according to the [sign conventions](#) for internal forces, that they act in opposite direction either side of the cut, and they cancel out if the object is put back together.

Either free-body diagram can be used to solve for the internal forces, so it is wise to choose the easier one. Recognizing which one is easier takes practice,

but look for the piece with more known and fewer unknown values.

This technique can be used to find the internal forces at any point within any object. In the examples below we will find the internal loadings at a specific point in load carrying beams.

Example 8.3.3 Internal forces in a simply supported beam.

A beam of length L is supported by a pin at A and a roller at B and is subjected to a horizontal force F applied to point B and a uniformly distributed load over its entire length. The intensity of the distributed load is w with units of [force/length].

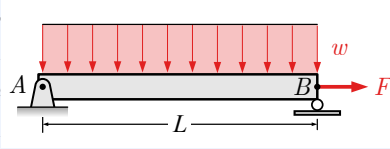

Find the internal forces at the midpoint of the beam.

Solution.

1. Find the external reactions.

Begin by drawing a free-body diagram of the entire beam, simplified by replacing the distributed load w with an equivalent concentrated load at the centroid of the rectangle.

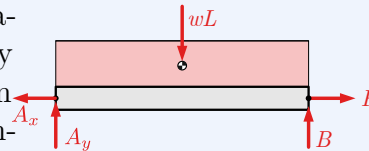

The magnitude of the equivalent load W is equal to the “area” under the rectangular loading curve.

$$W = w(L)$$

Then apply and simplify the equations of equilibrium to find the external reactions at A and B .

$$\begin{aligned}\Sigma M_A &= 0 \\ -(wL)(L/2) + (B)L &= 0 \\ B &= wL/2\end{aligned}$$

$$\begin{aligned}\Sigma F_x &= 0 \\ -A_x + F &= 0 \\ A_x &= F\end{aligned}$$

$$\begin{aligned}\Sigma F_y &= 0 \\ A_y - wL + B &= 0 \\ A_y &= wL - wL/2 \\ &= wL/2\end{aligned}$$

2. *Cut the beam.*

Cut the beam at the point of interest and separate the beam into two sections. Notice that as the beam is cut in two, the distributed load w is cut as well. Each of these distributed load halves will support equivalent point loads of $wL/2$ acting through the centroid of each cut half.

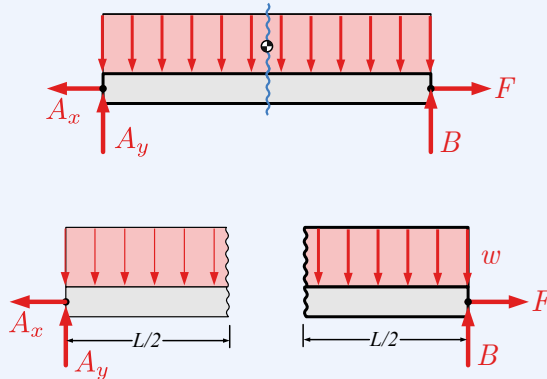
3. *Add the internal forces.*

At each cut, a shear force, a normal force, and a bending moment will be exposed, and these need to be included on the free-body diagram.

At this point, we don't know the actual directions of the internal forces, but we do know that they act in opposite directions. We will assume that they act in the positive sense as defined by the [standard sign convention](#).

Axial forces are positive in tension and act in opposite directions on the two halves of the cut beam.

Positive shear forces act down when looking at the cut from the right, and up when looking at the cut from the left. An alternate definition of positive shears is that the positive shears cause clockwise rotation. This definition is useful if you are dealing with a vertical column instead of a horizontal beam.

Bending moments are positive when the moment tends to bend the beam into a smiling U-shape. Negative moments bend the beam into a frowning shape.

For vertical columns, positive bending moments bend a beam into a C shape and negative into a backward C-shape.

The final free-body diagrams look like this.

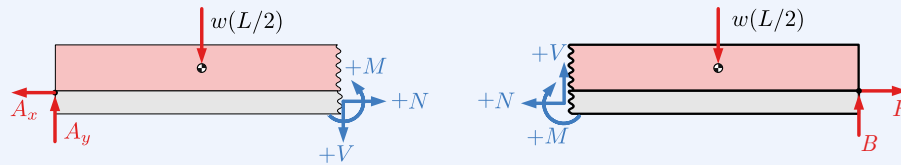

Horizontal beams should always have assumed internal loadings in these directions at the cut, indicating that you have assumed *positive* shear, *positive* normal force and *positive* bending moments at that point.

4. *Solve for the internal forces.*

You may use either FBD to find the internal forces using the techniques you have already learned. So, with a standard xy coordinate system, forces to the right or up are positive when summing forces and counter-clockwise moments are positive when summing moments.

Using the left free-body diagram and substituting in the reactions, we get:

$$\begin{aligned}\Sigma F_x &= 0 \\ -A_x + N &= 0 \\ N &= A_x\end{aligned}$$

$$\begin{aligned}\Sigma F_y &= 0 \\ A_y - wL/2 - V &= 0 \\ V &= wL/2 - wL/2 \\ V &= 0\end{aligned}$$

$$\begin{aligned}\Sigma M_{\text{cut}} &= 0 \\ (wL/2)(L/4) - (A_y)(L/2) + M &= 0 \\ M &= -wL^2/8 + wL^2/4 \\ M &= wL^2/8\end{aligned}$$

Using the right side free-body diagram we get:

$$\begin{aligned}\Sigma F_x &= 0 \\ -N + F &= 0 \\ N &= F\end{aligned}$$

$$\Sigma F_y = 0$$

$$V - wL/2 + B_y = 0$$

$$V = wL/2 - B_y$$

$$V = wL/2 - wL/2$$

$$V = 0$$

$$\Sigma M_{\text{cut}} = 0$$

$$-M - (L/4)(wL/2) + (L/2)(B_y) = 0$$

$$M = -wL^2/8 + wL^2/4$$

$$M = wL^2/8$$

Regardless of which side is chosen, we get the same results for the internal forces at the chosen point.

When you solve for the internal forces, the results can be either positive, negative, or sometimes zero. Negative values indicate that the actual direction of the load is opposite to the assumed direction. Since we assumed all three internal forces were positive as defined by the [standard sign convention](#), a negative answer means that the load actually acts in the opposite direction to the vector shown on the free-body diagram.

Example 8.3.4 Internal forces in a cantilever beam.

Consider a cantilever beam which is supported by a fixed connection at A , and loaded by a vertical force P and horizontal force F at the free end B . Determine the internal forces at a point a distance a from the left end.

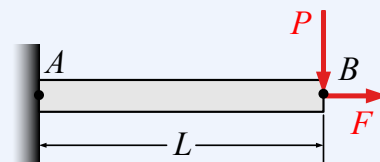

Hint. If you think ahead, you may not need to find the reactions at A .

Solution.

1. Determine the reactions.

Draw an FBD of the entire, uncut beam and determine the reactions.

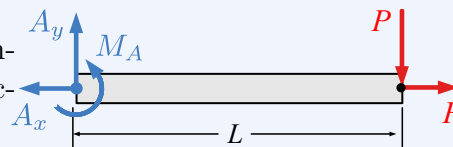

Notice that only the applied loads and support reactions are included on this uncut beam FBD. The internal forces are only exposed and shown on a FBD after the beam is cut.

Use this free-body diagram and the equations of equilibrium to de-

termine the external reaction forces.

$$\begin{aligned}\Sigma F_x = 0 &\implies A_x = F \\ \Sigma F_y = 0 &\implies A_y = P \\ \Sigma M_A = 0 &\implies M_A = PL\end{aligned}$$

2. *Section the beam.*

Take a cut at the point of interest and draw a FBD of either or both parts. Try to choose the simpler free-body diagram. If one side has no external reactions, then you can skip the previous step if you choose that side.

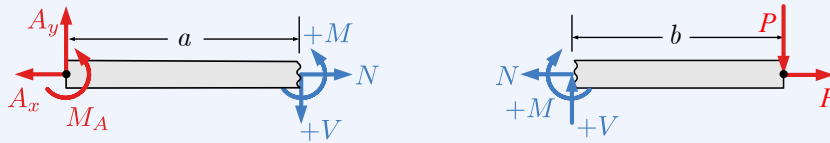

The free-body diagrams of both portions have been drawn with the internal forces and moments drawn in the positive direction defined by the [standard sign convention](#).

The axial force is shown in tension on both parts. This force has been named N so its name doesn't conflict with the forces at point A .

The shear force V is positive when the shear is down on the right face of the cut and up on the left face.

The bending moment M is positive if the bending direction would tend to bend the beam into a concave upward curve.

Always assume that the unknown internal forces act in the positive direction as defined by the standard sign convention.

3. *Solve for the internal forces.*

Selecting the right hand diagram and solving for the unknown internal forces gives:

$$\begin{aligned}\Sigma F_x = 0 &\implies N = F && \text{from before } F = A_x \\ \Sigma F_y = 0 &\implies V = P && \text{from before } P = A_y \\ \Sigma M_{\text{cut}} = 0 &\implies M = -Pb = -P(L - a) && \text{since } a + b = L\end{aligned}$$

. Solving the other free-body diagram would produce the same results

Once you have found the reactions and drawn a free-body diagram of the simpler portion with the normal force, shear force, and bending moment assumed positive, you then solve for the unknown values and signs just like any other equilibrium problem.

This workflow typically includes:

- Establishing a horizontal x and vertical y coordinate system.
- Taking a cut at the point of interest.
- Assuming that the internal forces act in the positive direction and drawing a free-body diagram accordingly
- Using $\Sigma F_x = 0$, $\Sigma F_y = 0$, and $\Sigma M_z = 0$ to solve for the three unknown internal forces.

The shear force V , normal force N , and bending moment M are scalar components and they may be positive, zero, or negative depending on the applied loads. The signs of the scalar components together with the sign convention for internal forces establish the actual directions of the shear force, normal force and bending moment vectors.

8.3.1 Interactive Internal Forces

The internal forces and bending moments inside a beam depend on the load that the beam is supporting and differ from point to point. This simply supported beam supports a uniformly varying load. The interactive traces out the value of the shear and bending moment as you move point C . Can you deduce the relation between the triangular loading and the value of the shear and bending moment?

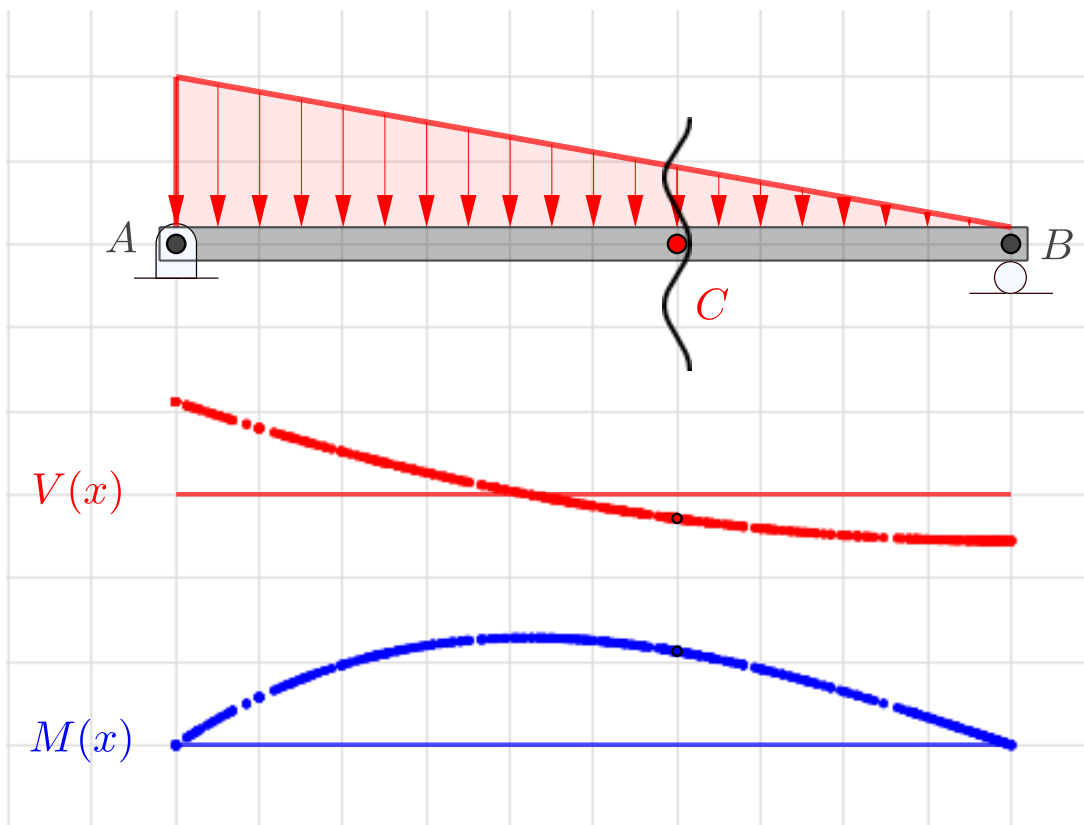

[Live Link](#)

Figure 8.3.5 Internal forces in a beam with a uniformly varying load.

8.4 Shear and Bending Moment Diagrams

Shear and moment diagrams are graphs which plot the internal shear and bending moment against the length of the beam.

They allow us to *see* the internal forces throughout the entire beam so that we can optimize the design to prevent failures and reduce the overall weight and cost of the structure. A beam is most likely to fail at points where shear and moment are greatest and these diagrams help us find these points.

The previous section presented a method to find the internal forces at a *single* point, which is useful; but to find the shear and moment at *every* point we need a more powerful approach. The following sections discuss three different methods to produce shear and bending moment diagrams, and concludes with a comparison of the advantages and disadvantages of each approach.

Beams can be supported in a variety of ways as shown in [Figure 8.4.1](#). The common support methods are

- **Simply Supported** Supported by a pin on one end and a roller at the other.
- **Cantilevered** Fixed at one end, and unsupported at the other.
- **Overhanging** One or both ends overhang the supports.

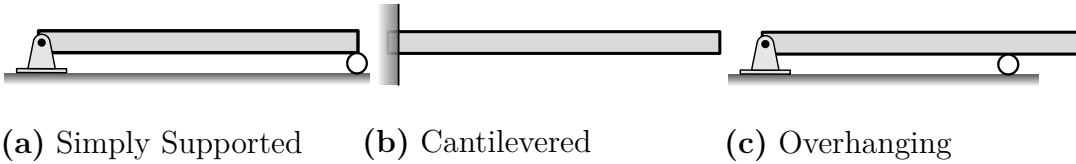

Figure 8.4.1 Beam Supports

We will limit our analysis to these three support systems, and since beams primarily support vertical loads, axial forces will not be considered in this section.

8.5 Relations between Loading, Shear and Moment

Shear and bending moment diagrams are used to show how load on a beam affects the shear and bending moment within.

In this section, we will look at a completely general beam and loading, and use a free-body diagram and the principles of equilibrium to derive the fundamental mathematical relationships that exist between load, shear, and bending moment.

Then in the sections to follow, we will learn three methods to produce shear and bending moment diagrams: an equilibrium based approach, a graphical integration method, and a calculus-based analytical approach. All three methods are consistent with the equations derived in this section and understanding them all can be insightful.

Suppose that we have a simply supported beam upon which there is a load $w(x)$ which acts on the beam by some arbitrary function of x , as shown in [Figure 8.5.1](#).

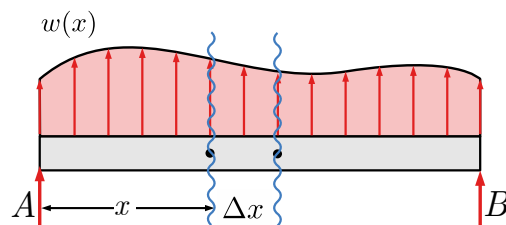

Figure 8.5.1 A simply supported beam with a distributed load that is a function of beam position $w(x)$.

For a thin section of this beam between x and $x + \Delta x$, we can assume that the distributed load is approximately constant and equal to $w = w(x)$. With

this assumption, the distributed load is rectangular, and equivalent to a force $W = w\Delta x$ acting at the centroid of the rectangle. The free-body diagram for this thin section is shown in [Figure 8.5.2](#).

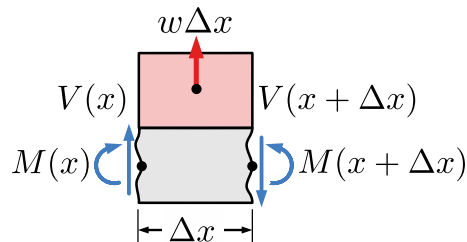

Figure 8.5.2 A free-body diagram of a small section of the beam with a width of Δx .

Applying the force equilibrium in the vertical direction gives the following result:

$$\begin{aligned}\sum F_y &= 0 \\ V + w\Delta x &= (V + \Delta V) \\ \Delta V &= w\Delta x \\ \frac{\Delta V}{\Delta x} &= w\end{aligned}$$

Taking the limit of both sides as Δx approaches 0, we get this important result

$$\begin{aligned}\lim_{\Delta x \rightarrow 0} \left(\frac{\Delta V}{\Delta x} \right) &= \lim_{\Delta x \rightarrow 0} (w) \\ \frac{dV}{dx} &= w(x)\end{aligned}\tag{8.5.1}$$

This differential equation tells us that at a given location x , the slope of the shear function at that point is the value of the loading directly above, $w(x)$.

Furthermore, if we separate the variables by multiplying both sides by dx , and then integrate between any two points along the beam we find that

$$\Delta V = \int_a^b w(x) dx\tag{8.5.2}$$

In words, this equation says that the change in the shear ΔV between any two points a and b , is the area under the loading curve between them.

Next, considering moment equilibrium of the FBD in [Figure 8.5.2](#), and following the same procedure, we get:

$$\begin{aligned}\sum M &= 0 \\ (M + \Delta M) &= \frac{\Delta x}{2}V + \frac{\Delta x}{2}(V + \Delta V) + M\end{aligned}$$

$$\Delta M = \left(V + \frac{\Delta V}{2}\right)\Delta x$$

Separating variables and taking limits as before, gives:

$$\begin{aligned} \lim_{\Delta x \rightarrow 0} \left(\frac{\Delta M}{\Delta x}\right) &= \lim_{\Delta x \rightarrow 0} \left(V + \frac{\Delta V}{2}\right) \\ \frac{dM}{dx} &= V(x) \end{aligned} \quad (8.5.3)$$

This equation tells us that at any point on the beam the slope of the moment function is equal to the value of the shear at that point.

Furthermore, if we multiply both sides by dx , we can integrate to find that

$$\Delta M = \int_a^b V(x) dx \quad (8.5.4)$$

In words, this equation says that over a given segment, the change in the moment value is the area under the shear curve.

Summary. The internal shear force $V(x)$, bending moment $M(x)$, and loading $w(x)$ at every point x are related to each other by the integral and differential equations below.

$$\frac{dV}{dx} = w(x)$$

The slope of the shear function at x is the value of the loading function at the same position. An upward load is considered a positive load.

$$\Delta V = \int_a^b w(x) dx$$

The change in the shear value between two points is the area under the loading function between those points.

$$\frac{dM}{dx} = V(x)$$

The slope of the moment function at x is the value of the shear at the same position.

$$\Delta M = \int_a^b V(x) dx$$

The change in the moment value between two points is the area under the shear curve between those points.

Remark 8.5.3 Sign Conventions.

It is sometimes convenient to assume that positive loads act down, and not up as we have assumed here. In that case simply substitute $-w(x)$ for $w(x)$ into and equations (8.5.1) and (8.5.2) and use these variations instead:

$$\frac{dV}{dx} = -w(x) \quad \Delta V = - \int_a^b w(x) dx \quad (8.5.5)$$

Thinking Deeper 8.5.4 What happens if we keep integrating?

As we have seen, integrating the load function once gives the shear force, and integrating the shear force gives the bending moment.

You may be wondering what happens if we keep integrating? Does this produce anything interesting?

In fact it does, as you will see in Mechanics of Materials. In the Statics world, all beams are assumed to be rigid, but in the real world they deform under load. The shape the beam takes on is described by a deflection curve which gives the actual displacement of the beam at any given point due to the applied loads

Integrating the bending moment $M(x)$ (and dividing by the flexural rigidity, EI) gives the slope of the deflection curve, which represents the angle of the beam's deformation at any given point.

Integrating that function once more (and dividing by EI again) gives the actual deflection function.

So, if you keep integrating the load function, you're essentially moving through these stages of beam analysis, progressing from the applied forces to the resulting deformation: Load \rightarrow Shear \rightarrow Moment \rightarrow Slope \rightarrow Deflection. Each step provides valuable information about the beam's behavior under the given loading conditions.

8.6 Section Cut Method

In this section we'll extend the method of [Section 8.3](#) where we found the internal forces at a specific point to find the internal forces at every point needed to produce a shear and bending moment diagram.

The procedure is identical except that the cut is taken at a position designated by x instead of at a specified point. The analysis produces *equations* as functions of x rather than *values* at a particular x . Shear and bending moment diagrams are plots of these equations, and the internal forces at any particular point can be found by substituting that particular value of x into the equations.

We will use a cantilevered beam fixed to a wall on the left end and subjected to a vertical force P on the right end as an example. Global equilibrium requires that the reactions at the fixed support at A are a vertical force $A_y = P$, and a counter-clockwise moment $M_A = PL$.

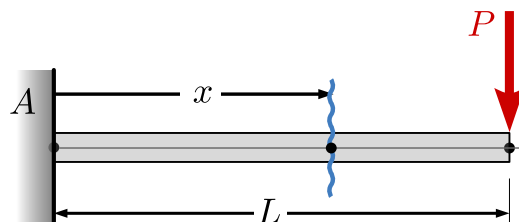

By taking a cut at a distance x from the left we can draw two free-body diagrams with lengths x and $(L - x)$. This beam has *one* loading segment, because no matter where x is chosen, the free-body diagrams shown in [Figure 8.6.1](#) (b) and (c) are correct. The internal loadings are named $V(x)$ and $M(x)$ to indicate that they are functions of x and are drawn with positive sense as defined in [Section 8.2](#).

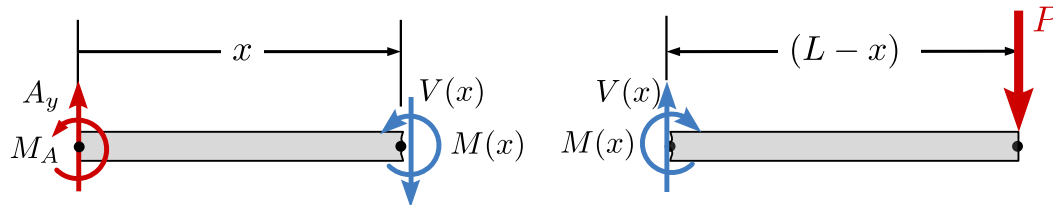

(a) Left FBD.

(b) Right FBD.

Figure 8.6.1

To find the shear and bending moment functions, we apply the equilibrium to one of the free-body diagrams. Either side will work, so we'll select the right-hand portion [Figure 8.6.1\(b\)](#) since it doesn't require us to find the reactions at A . Letting L be the length of the beam and $(L - x)$ the length of the right portion, we find

$$\begin{aligned} \Sigma F_y &= 0 & \Sigma M_{\text{cut}} &= 0 \\ V(x) &= P & M(x) &= -P(L - x) \end{aligned}$$

The plots of the equations for $V(x)$ and $M(x)$ are shown below in [Figure 8.6.2](#). These equations indicate that the shear force $V(x)$ is constant P over the length of the beam and the moment $M(x)$ is a linear function of the position of the cut, x starting at $-PL$ at $x = 0$ and linearly increasing to zero at $x = L$. Note that the graphs are only valid from $0 \leq x \leq L$, so the curves outside this range are shown as dotted lines. These two graphs are usually drawn stacked beneath the load diagram of the beam.

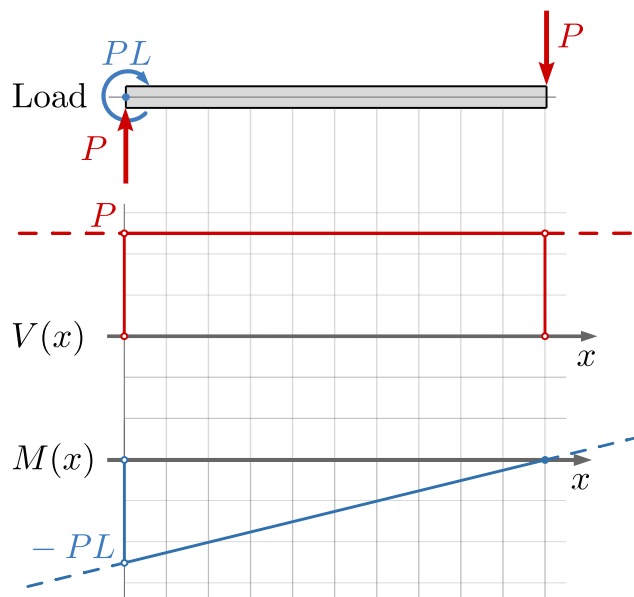

Figure 8.6.2 Shear and Bending Moment Diagrams for Cantilever Beam

The previous example was simple because only one FBD was necessary for any point on the beam, but many beams are more complex. Beams with multiple loads must be divided into loading segments between the points where loads are applied or where distributed loads begin or end.

Consider the simply supported beam AD with a uniformly distributed load w over the first segment from A to B , and two vertical loads B and C .

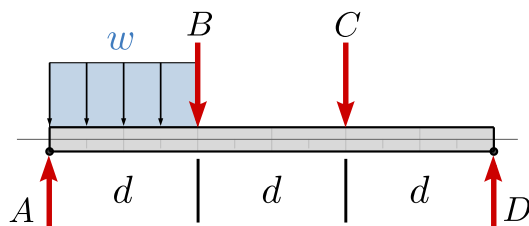
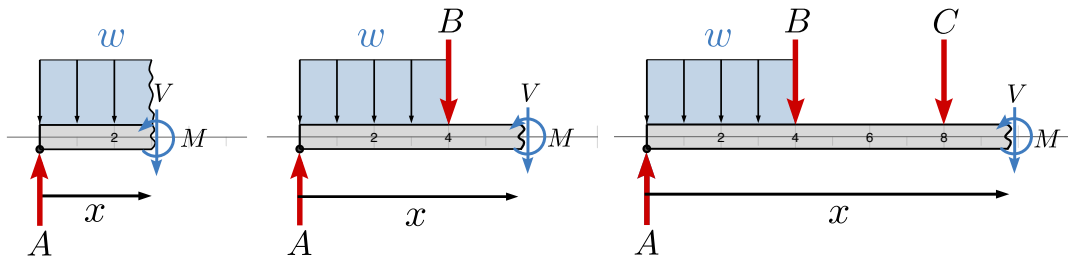

Figure 8.6.3 Simply Supported Beam with Uniformly Distributed Load

This beam has three loading segments so you must draw three free-body diagrams and analyze each segment independently. For each, make an imaginary cut through the segment, then draw a new free-body diagram of the portion to the left (or right) of the cut. Always assume that the exposed internal shear force and internal bending moment act in the positive direction according to the [sign convention](#).



(a) $0 < x < d$ (b) $d < x < 2d$ (c) $2d < x < 3d$

Figure 8.6.4

After the equilibrium equations are applied to each segment, the resulting equations $V(x)$ and $M(x)$ from each segment are joined to plot the shear and moment diagrams. These diagrams help us visualize the values of V and M throughout the beam.

Example 8.6.5 Section Cut Method.

Draw the shear and bending moment diagrams for the beam of [Figure 8.6.3](#) knowing that d is 4 m, forces B and C are both 10 N, and the uniformly distributed load $w(x) = 15 \text{ N/m}$

Solution.

1. Replace the 15 N/m with an equivalent force of 60 N acting at the centroid of the the rectangular loading, and draw a free body diagram of the whole beam.

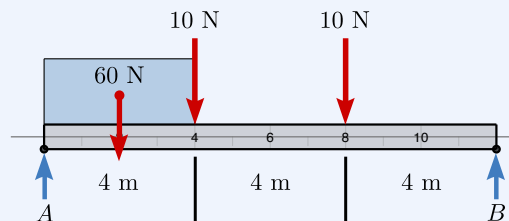

2. Take moments about B to find the reaction at A .

$$A = \frac{60(10) + 10(8) + 10(4)}{12}$$

3. Draw a free-body diagram of the section of the beam between $0 < x < 4 \text{ m}$.

The loading on this segment of the beam is $w(x) = 15 \text{ N/m}$, acting down and constant. The equivalent force is the area of the rectangle $W = 15x$, which is a first degree function of x .

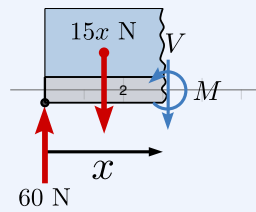

4. Apply the equations of equilibrium to find the shear and moment functions for the segment $0 < x < 4$.

$$\begin{aligned}\Sigma F_y &= 0 \\ 60 - 15x - V &= 0 \\ V &= 60 - 15x \text{ N}\end{aligned}\quad (8.6.1)$$

$$\begin{aligned}\Sigma M_{\text{cut}} &= 0 \\ -60x + (15x) \left(\frac{x}{2}\right) + M &= 0 \\ M &= 60x - 7.5x^2 \text{ N}\cdot\text{m}\end{aligned}\quad (8.6.2)$$

5. Follow a similar procedure for the next segment $4 < x < 8$

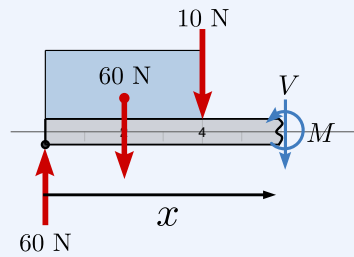

$$\Sigma F_y = 0 : \quad V = -10 \text{ N} \quad (8.6.3)$$

$$\Sigma M_{\text{cut}} = 0 : \quad M = 160 - 10x \text{ N}\cdot\text{m} \quad (8.6.4)$$

6. And again for the third segment $8 < x < 12$

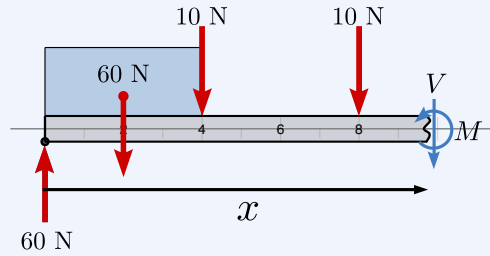

$$\Sigma F_y = 0 : \quad V = -20 \text{ N} \quad (8.6.5)$$

$$\Sigma M_{\text{cut}} = 0 : \quad M = 240 - 20x \text{ N}\cdot\text{m} \quad (8.6.6)$$

7. Neatly plot these functions on appropriately scaled graph paper

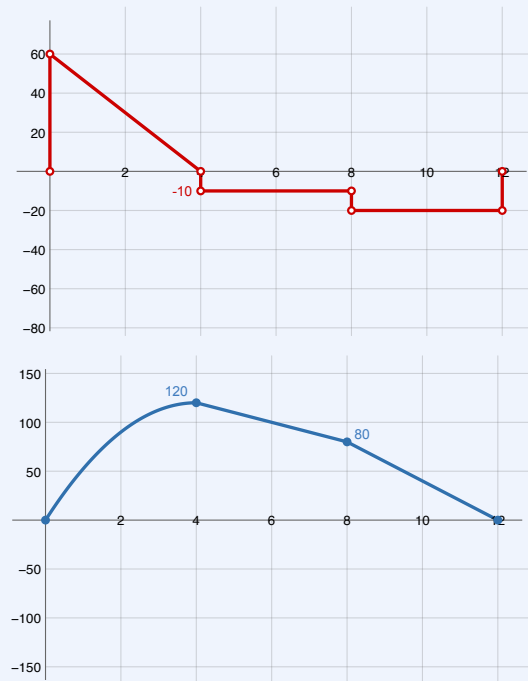

Note that this method does not give us shear and moment values at exactly $x = 4 \text{ m}$ and $x = 8 \text{ m}$. Discontinuities occur at these locations, and the shear function has different values when approaching 4 and 8 from the left and from the right!

8.7 Graphical Method

Once you have a firm grasp on the relations between load, shear and bending moments, you can quickly draw shear and bending moment diagrams using a graphical approach. This technique is really a graphical integration process;

rather than using calculus, the integrals are found using simple geometry.

8.7.1 Relationship Review

Shear and bending moment diagrams are governed by equations (8.5.1) through (8.5.4) and must be consistent with them.

$$\begin{aligned} \frac{dV}{dx} &= w(x) & \frac{dM}{dx} &= V(x) \\ \Delta V &= \int_a^b w(x) dx & \Delta M &= \int_a^b V(x) dx \end{aligned}$$

From top to bottom, the shear function is determined from the area under the load, and the moment function is determined from the area under the shear function. At the same time, from bottom to top, differentiating the moment function gives the shear function, and differentiating the shear function gives the load.

Shear and bending moment are piecewise functions made up of a series of jumps, slopes and areas. **Jumps** are vertical changes in shear and moment diagrams caused by concentrated forces and moments. **Slopes** are gradual changes in the functions. **Areas** are the ‘areas’ under the loading and shear curves, i.e. the integral. The area under the loading curve is actually a force, and the area under the shear curve is actually a bending moment.

The relationship between load, shear, and bending moment are summarized below.

Shear Diagram

Jumps	Concentrated forces cause the shear curve to jump by the amount of the force. Upward loads cause upward jumps.
Slopes	The slope of the shear diagram at a point is equal to the value of the distributed load above that point. Downward distributed loads create negative slopes on the shear diagram.
Areas	The area under the loading curve between two points is equal to the corresponding change in value of the shear.

Moment Diagram

Jumps	Concentrated moments cause the moment curve to jump by the amount of the moment. Counterclockwise moments cause downward jumps.
Slopes	The slope of the moment diagram at a point is equal to the value of the shear at that point. Positive shears cause positive slopes on the moment diagram.
Areas	The area under the shear curve between two points is equal to the corresponding change in the value of the moment.

You can use the interactive below to explore how changes to concentrated load P and distributed load w affect the slopes, jumps, and areas of the resulting shear and bending moment diagrams.

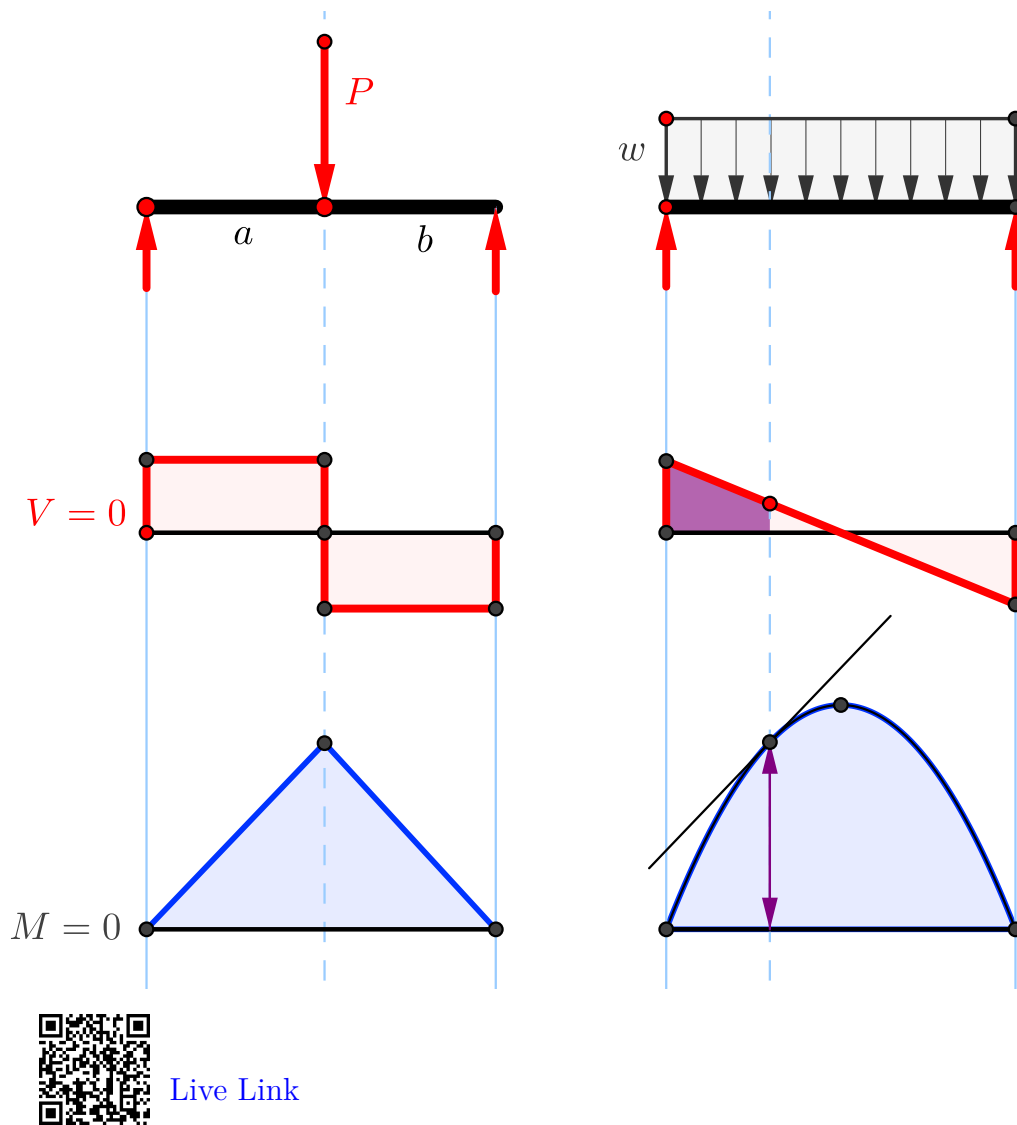

Figure 8.7.1 Building Blocks for Shear and Moment Diagrams

8.7.2 Graphical Method Procedure

You can draw shear and bending moments efficiently and accurately using this procedure

1. First, *determine the reaction forces* and moments by drawing a free-body diagram of the entire beam and applying the equilibrium equations. Double check that your reactions are correct.
2. Establish the shear graph with a horizontal axis below the beam and a vertical axis to represent shear. Positive shears will be plotted above the x axis and negative below.

3. Make vertical lines at all the “interesting points”, i.e. points where concentrated forces or moments act on the beam and at the beginning and end of any distributed loads. This divides the beam into segments between vertical lines.
4. *Draw the shear diagram* by starting with a dot at $x = 0$, $V = 0$ then proceeding from left to right until you reach the end of the beam. Choose and label a scale which keeps the diagram a reasonable size.
 - (a) Whenever you encounter a concentrated force, jump up or down by that value
 - (b) Whenever you encounter a concentrated moment, do not jump.
 - (c) Whenever you encounter a distributed load, move up or down by the “area” under the loading curve over the length of the segment, according to equation (8.5.2). The “area” is actually a force.
 - (d) The slope of the curve at each point x is given by (8.5.1). Distributed loads cause the shear diagram to have a slope equal to value of the distributed load at that point. For unloaded segments of the beam, the slope is zero, i.e. the shear curve is horizontal. For segments with uniformly distributed load, the slope is constant. Downward loads cause downward slopes.
 - (e) The shear diagram should start and end at $V = 0$. If it doesn't, recheck your work.
5. Add another interesting point wherever the shear diagram crosses the x -axis, and determine the x position of the zero crossing.
6. After you have completed the shear diagram, *calculate the area under the shear curve* for each segment. Areas above the axis are positive, areas below the axis are negative. The areas represent moments and the sum of the areas plus the values of any concentrated moments should add to zero. If they don't, then recheck your work.
7. Establish the moment graph beneath the shear diagram with a horizontal axis below the shear diagram and a vertical axis to represent moment. Positive moments will be plotted above the x axis and negative below.
8. *Draw and label dots on the moment diagram* by starting with a dot at $x = 0$, $M = 0$ then proceed from left to right placing dots until you reach the end of the beam. As you move over each segment move up or down from the current value by the “area” under the shear curve for that segment and place a dot on the graph. In this step, you are applying (8.5.4).
 - (a) Positive areas cause the moment to increase, negative areas cause it to decrease.

- (b) If you encounter a concentrated moment, jump straight up or down by the amount of the moment and place a dot. Clockwise moments cause upward jumps and counter-clockwise moments cause downward jumps.
- (c) When you reach the end of the beam you should return to $M = 0$. If you don't, then recheck your work.
9. *Connect the dots with correctly shaped lines.* Segments under constant shear are straight lines, segments under changing shear are curves. The general curvature of the lines can be determined by considering equation (8.5.3).

Example 8.7.2 Graphical Method: Combined Loads.

Draw a neat, accurate, labeled shear and bending moment diagram for the beam and loading shown using the method of this section. Distance units are in feet.

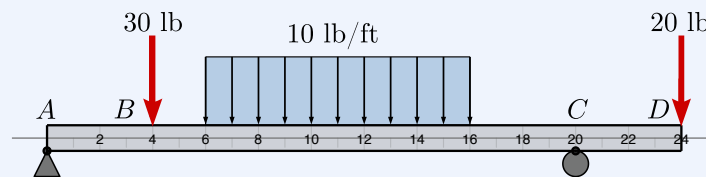

Solution. Click the buttons below to step through the solution.

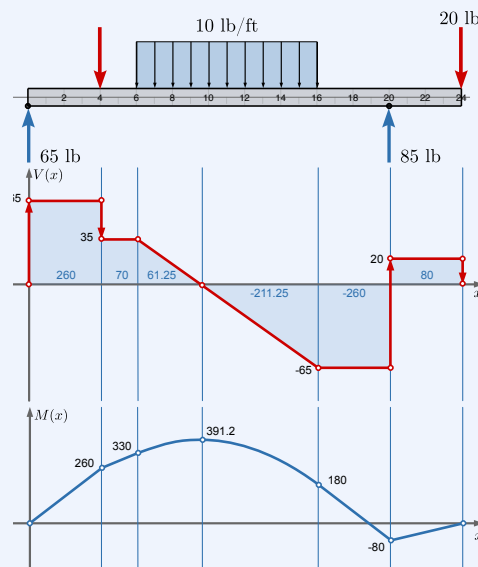

Standalone
In Context
Embed

Example 8.7.3 Graphical Method: Concentrated Moments.

Draw a neat, accurate, labeled shear and bending moment diagram for the 15 m long beam loaded as shown using the method of this section.

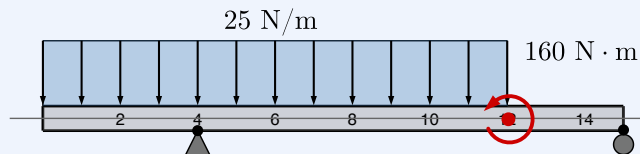

Solution. Click the buttons below to step through the solution.

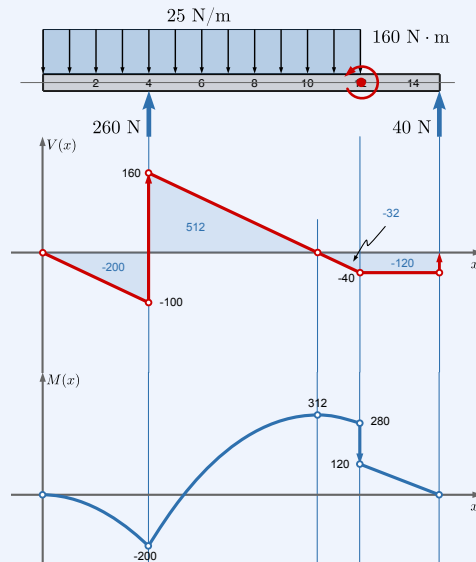

[Standalone](#)
[In Context](#)
[Embed](#)

Remark 8.7.4 Tips for Drawing Good Shear and Bending Moment Diagrams.

1. Work neatly and professionally, and take pride in your work. Use a straightedge!
2. Draw a labeled free-body diagram of the entire structure, and your work to find the reactions off to the side. For this free-body diagram, you may replace the distributed loads with equivalent concentrated loads.
3. Next draw a careful sketch of the beam showing its reactions and the *actual* distributed loads. Distributed loads must be shown here, because their distributed nature is significant.
4. Draw the shear diagram directly below the load diagram and the moment diagram beneath that. It is convenient to draw these graphs on graph paper. Indicate the scale used each function.
5. Downward forces make the shear diagram move down, counterclockwise concentrated moments make the moment curve jump down.

6. Show the correct shape and curvature for each curve segment: zero, constant slope, polynomial. Changes in curve shapes should align with the load which causes them.
7. Indicate the values of shear and moment at maximums, minimums and points of inflection.
8. Include any other work needed to justify your results.

8.8 Integration Method

In [Section 8.5](#) we saw that loading, shear and bending moments are related by integral and differential equations, and in [Subsection 8.7.2](#) used this knowledge to draw shear and bending moment diagram using a graphical approach. This method is straightforward and fast for concentrated forces and uniformly distributed loads, because they produce triangular and rectangular areas that are easy to calculate but it falls short when the areas are more complicated.

For example, a uniformly varying load is a first degree linear function of x ,

$$w(x) = w_0x$$

It integrates to a second degree parabolic shear function, and a third degree cubic moment function. Finding the zero crossings and areas under these curves with geometry is troublesome. More complex loading functions are even more difficult.

When the loading becomes complex it is better to use the fundamental relations [\(8.5.2\)](#) and [\(8.5.4\)](#) to find the shear and bending moment functions directly

$$\Delta V = \int_a^b w(x) dx \qquad \Delta M = \int_a^b V(x) dx$$

Rather than finding areas and slopes using geometry, we will directly integrate the load function $w(x)$ once to find the shear function $v(x)$, then integrate that result to find the moment function $m(x)$.

These results are the change in shear and moment over a segment; to find the actual shear and moment functions $V(x)$ and $M(x)$ for the entire beam we will need to find initial values for each segment. This is equivalent to applying boundary conditions to find the constant of integration when solving a differential equation. The initial values come from either the final value of the previous segment or from point loads or point moments. Because of the requirement for these segment starting values, no segment can be computed in isolation from the other segments. Physically this means that the shear and moment along a beam are not just due to the loading in one segment, but are related to the loading on the rest of the beam as well.

8.8.1 Determining Loading Functions

Before you can find shear and bending moment functions with integration you must know the equation for the load on each segment of the beam. These equations may be given in the problem statement if you're lucky, or you may have to determine them from a loading diagram.

When determining equations for loading segments, you may choose either *global equations*, where all segments use the same origin, usually at the left end of the beam, or *local equations*, where each segment uses its own origin, usually at the left end of the segment. Often local equations are easier because you can simply use the variable x in your equations as opposed to " $x + \text{constant}$ ", and you do not have to project the y -intercept values back to an axis system which is not adjacent to the segment. See interactive [Figure 8.8.1](#) to explore the difference between local and global equations.

When determining equations for the loading segments from the load diagram, consider the following.

- *No load.*

Whenever there is no load at all on a segment there will be no change in the shear on the segment. On such sections the loading function is

$$w(x) = 0.$$

Note that this can only occur when the weight of the beam itself is neglected.

- *Point Load.*

A point load is a concentrated force acting at a single point which causes a jump in the shear diagram.

- *Uniformly Distributed Load.*

A uniformly distributed load is constant over the segment and results in a linear slope, either a triangle or a trapezoid, on the shear diagram. The loading function on such sections is

$$w(x) = C \quad V(x) = Cx + b.$$

The constant value is negative if the load points down, and positive if it points upward.

- *Uniformly Varying Load.*

In this case the loading function is a straight, sloping line forming a triangle or trapezoidal shape. The resulting shear function is parabolic. The general form of these functions are

$$w(x) = mx + b \quad V(x) = \frac{mx^2}{2} + bx + c.$$

The slope m , intercept b , and constant c must be determined from the situation, and will depend on whether you are writing a global or local equation.

- *Arbitrary Load.*

The loading function will be a given function of x .

$$w(x) = f(x),$$

and the shear and moment functions are found by integration.

$$V(x) = \int f(x)dx \quad M(x) = \int V(x)dx$$

Most gravitational distributed loads are drawn with the arrows pointing down and resting on the beam. If you slide these along their line of action so that their tails are on the beam, the tips define the loading equation. In other words, for downward pointing loads, the scalar values are negative.

This interactive compares the local and global equations for a beam segment with a uniformly varying load.

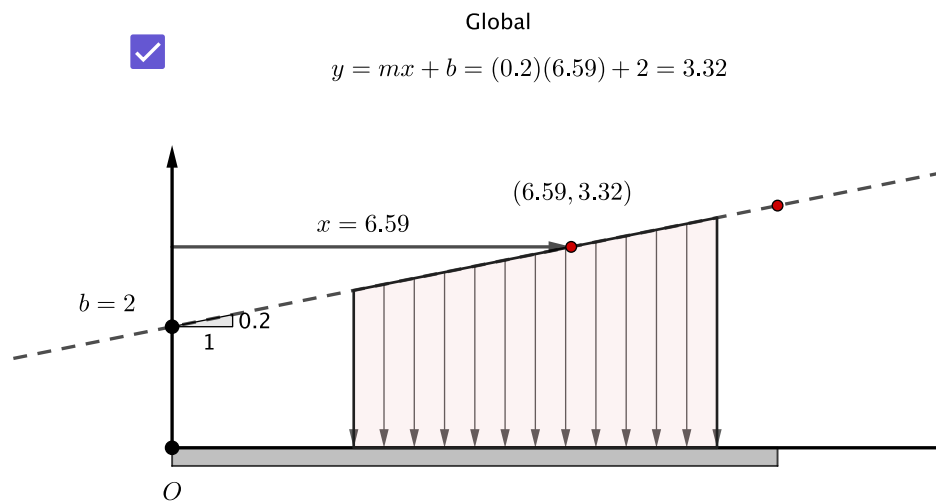

[Live Link](#)

Figure 8.8.1 Global vs. Local coordinate systems.

8.8.2 Application of the Integration Method

You can either use this method from the start or use the graphical method until you need areas of shapes more complicated than rectangles and triangles.

1. You will need to have solved the loading segment to the left of your desired segment.
2. Write an equation for the loading w in the segment using either local or global coordinates.
3. Integrate the loading equation $w(x)$ to find the change in the shear ΔV and include the shear value at the beginning of your loading segment including the influence of any point loads at that location, which is equivalent to the integration constant.
4. Integrate the shear equation $V(x)$ to find the change in the bending moment ΔM and include the moment value at the beginning of your loading segment including the influence of any point couple-moments at that location, equivalent to the integration constant.
5. To find maximum shear and bending moments, recall from calculus that the local maximum/minimum points of a function occur at the endpoints and where the function's first derivative is equal to zero.
 - (a) For shear, evaluate the shear function $V(x)$ at the ends and where ever the load function crosses the x axis.
 - (b) For bending moments, find the roots of the shear function by solving $V(x) = 0$, then evaluate the moment function $M(x)$ at these points, and also at the endpoints.

The critical values we are looking for are the points where the *magnitudes* of the shear and bending moment are maximum. The direction of the internal forces is not usually significant.

Example 8.8.2 Uniformly Distributed Load.

Use the integration method to find the equations for shear and moment as a function of x , for a simply supported beam carrying a uniformly distributed load w over its entire length L .

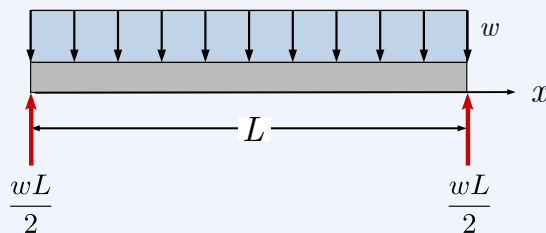

Solution.

This beam has only one load section, and on that section the load is constant and points down, so,

$$w(x) = -w.$$

There is a pinned connection at $x = 0$ which provides a vertical force and no concentrated moment, so the initial conditions there are $V(0) = wL/2$, and $M(0) = 0$.

Integrating equations (8.5.2) and (8.5.4) we have.

$$\begin{aligned}\Delta V &= - \int_0^x w(x) dx \\ V(x) - \cancel{V(0)} &= \overset{wL/2}{-wx} \\ V(x) &= \frac{wL}{2} - wx \\ &= w \left(\frac{L}{2} - x \right)\end{aligned}$$

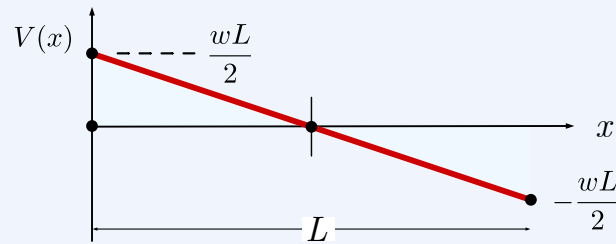

$$\begin{aligned}\Delta M &= \int_0^x V(x) dx \\ M(x) - \cancel{M(0)} &= \overset{0}{\int_0^x} w \left(\frac{L}{2} - x \right) dx \\ M(x) &= \frac{w}{2} (Lx - x^2)\end{aligned}$$

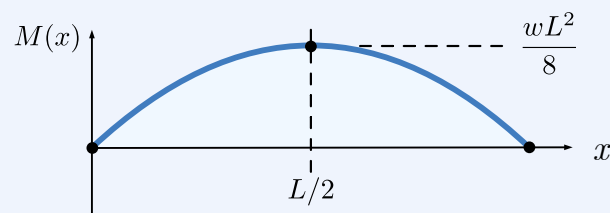

Example 8.8.3 Piecewise Function.

Consider a 20 m beam loaded as shown. Use the integration method to derive the shear and bending moment as functions of x and plot them.

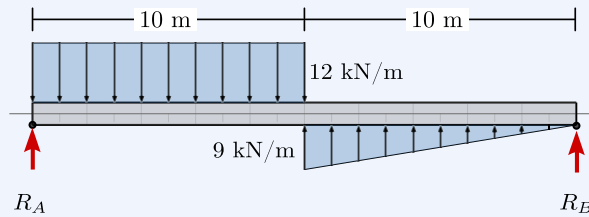
**Solution.**1. *Reactions.*

Find the reactions using the methods of [Section 7.8](#).

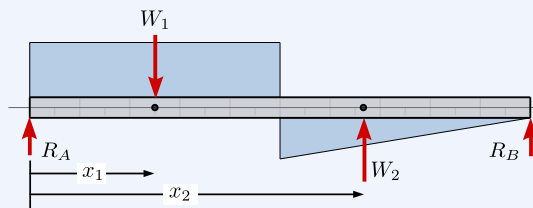

$$\Sigma M_A = 0$$

$$-W_1 x_1 + W_2 x_2 + R_B (20 \text{ m}) = 0$$

$$R_B (20 \text{ m}) = 120 \text{ kN} \cdot 5 \text{ m} - 45 \text{ kN} \cdot 13.33 \text{ m}$$

$$R_B = 0$$

$$\Sigma F_y = 0$$

$$R_A - W_1 + W_2 + R_B = 0$$

$$R_A = 120 \text{ kN} - 45 \text{ kN}$$

$$R_A = 75 \text{ kN}$$

2. *Segment 1.*

On the first half of the beam, for the range $x = 0$ up to and including $x = 10 \text{ m}$, the loading is constant and pointing down, so the loading function on this segment is

$$w_1(x) = -12 \text{ kN/m.}$$

Integrating twice gives the shear and bending moment functions on this segment

$$\begin{aligned}V_1(x) &= -12x + C_0 \\M_1(x) &= -6x^2 + C_0x + C_1\end{aligned}$$

Evaluating the boundary conditions, $V(0) = R_A$ and $M(0) = 0$ we learn that

$$\begin{aligned}C_0 &= 75 \text{ kN.} \\C_1 &= 0\end{aligned}$$

3. Segment 2.

To simplify the analysis of the second half of the beams we will use local coordinates by defining

$$x' = (x - 10).$$

In local coordinates, the function is valid over the range $0 < x' \leq 10$.

The load over this segment starts at 9 kN/m but decreases to zero after 10 m, so the slope is

$$m = \frac{-9 \text{ kN/m}}{10 \text{ m}} = -\frac{9}{10} \text{ kN/m}^2.$$

In terms of x' the load the loading function is

$$w_2(x') = 9 - \frac{9}{10}x'.$$

Integrating twice gives the shear and moment functions.

$$\begin{aligned}V_2(x') &= 9x' - \frac{9}{20}x'^2 + C_2 \\M_2(x') &= \frac{9}{2}x'^2 - \frac{3}{20}x'^3 + C_2x' + C_3\end{aligned}$$

The constants are evaluated by matching the functions at the boundary $x = 10$ m, where

$$\begin{aligned}V_1(10) &= -45 \text{ kN} \\M_1(10) &= 150 \text{ kN}\cdot\text{m}\end{aligned}$$

Evaluating $V_2(x')$ and $M_2(x')$ at $x' = 0$ we find that

$$\begin{aligned}C_2 &= -45 \text{ kN} \\C_3 &= 150 \text{ kN}\cdot\text{m}\end{aligned}$$

4. *Results.*

Combining results we get the final version of shear and bending moment functions in terms of x .

On the range $0 < x \leq 10$

$$V(x) = -12x + 75$$

$$M(x) = -6x^2 + 75x$$

On the range $10 < x \leq 20$

$$V(x) = -\frac{9}{20}(x - 10)^2 + 9(x - 10) - 45$$

$$M(x) = -\frac{3}{20}(x - 10)^3 + \frac{9}{2}(x - 10)^2 - 45(10 - x) + 150$$

A plot of the two functions is shown below. Notice how the two halves of each function joins continuously at $x = 10$ m.

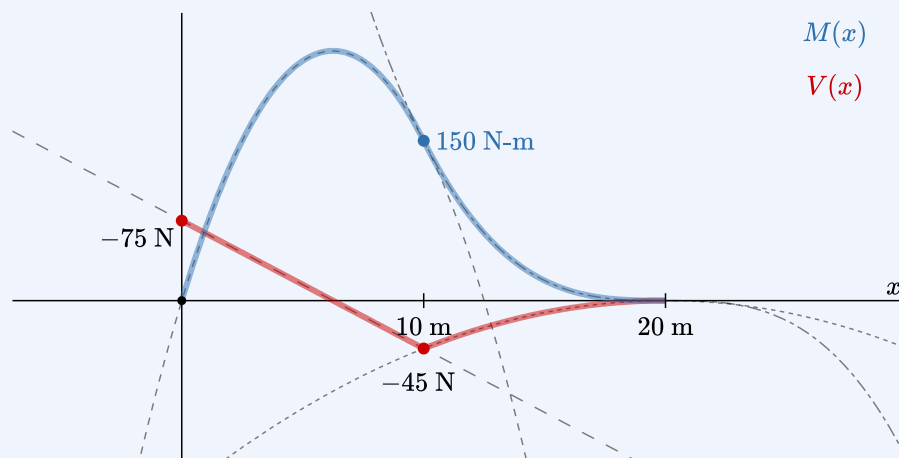

8.9 Geogebra Interactives

You can use the interactives below to practice drawing shear and bending moment diagrams. You can change the position of the loads and change their magnitudes and observe how the diagrams change, or you can click **New Problem** to generate a new problem.

After exploring the diagrams and seeing how they relate to each other, turn off the solutions and try for yourself. You will very likely see problems like these on an exam.

8.9.1 Concentrated Forces

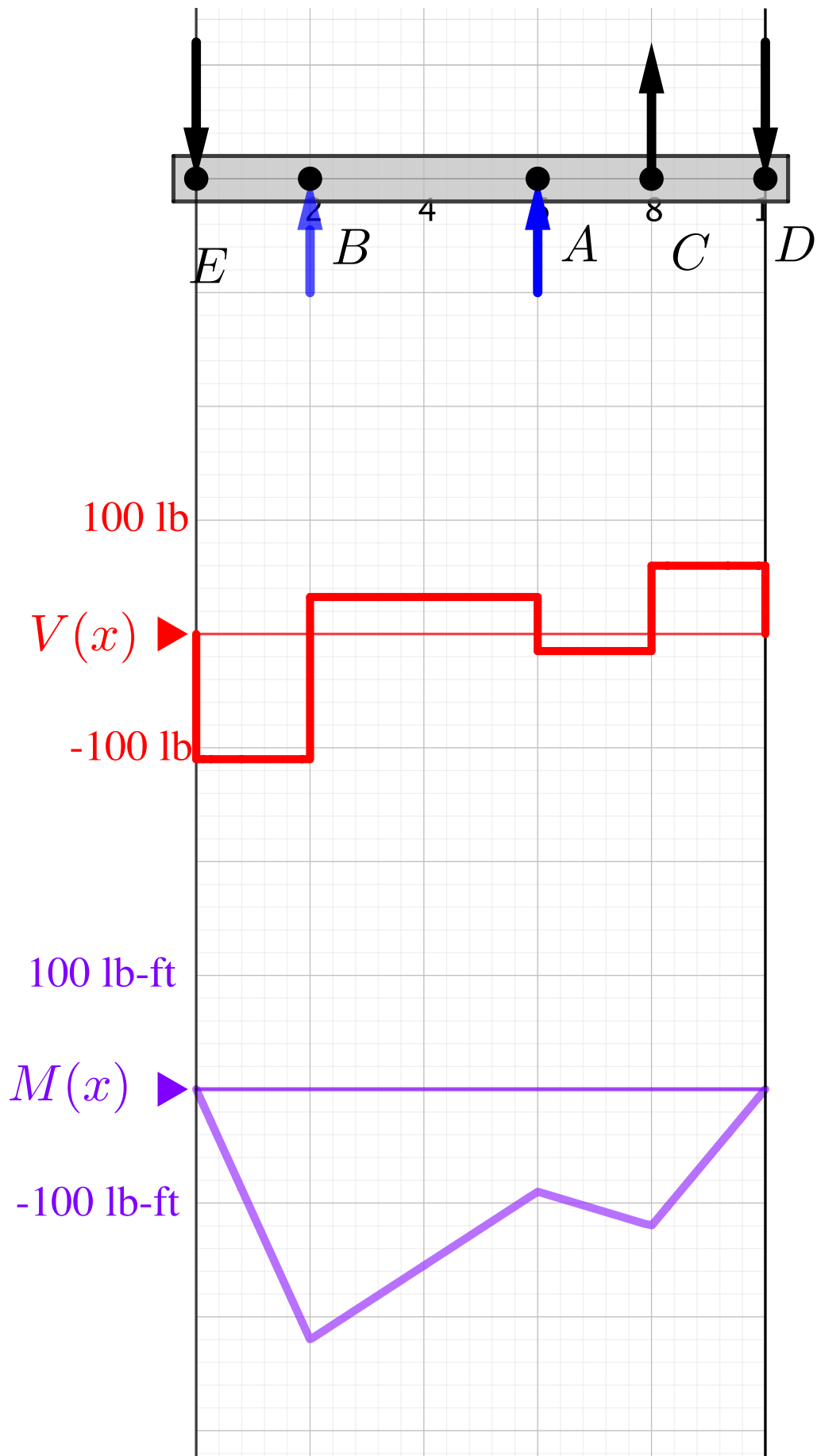



[Live Link](#)

8.9.2 Concentrated Force and Moment

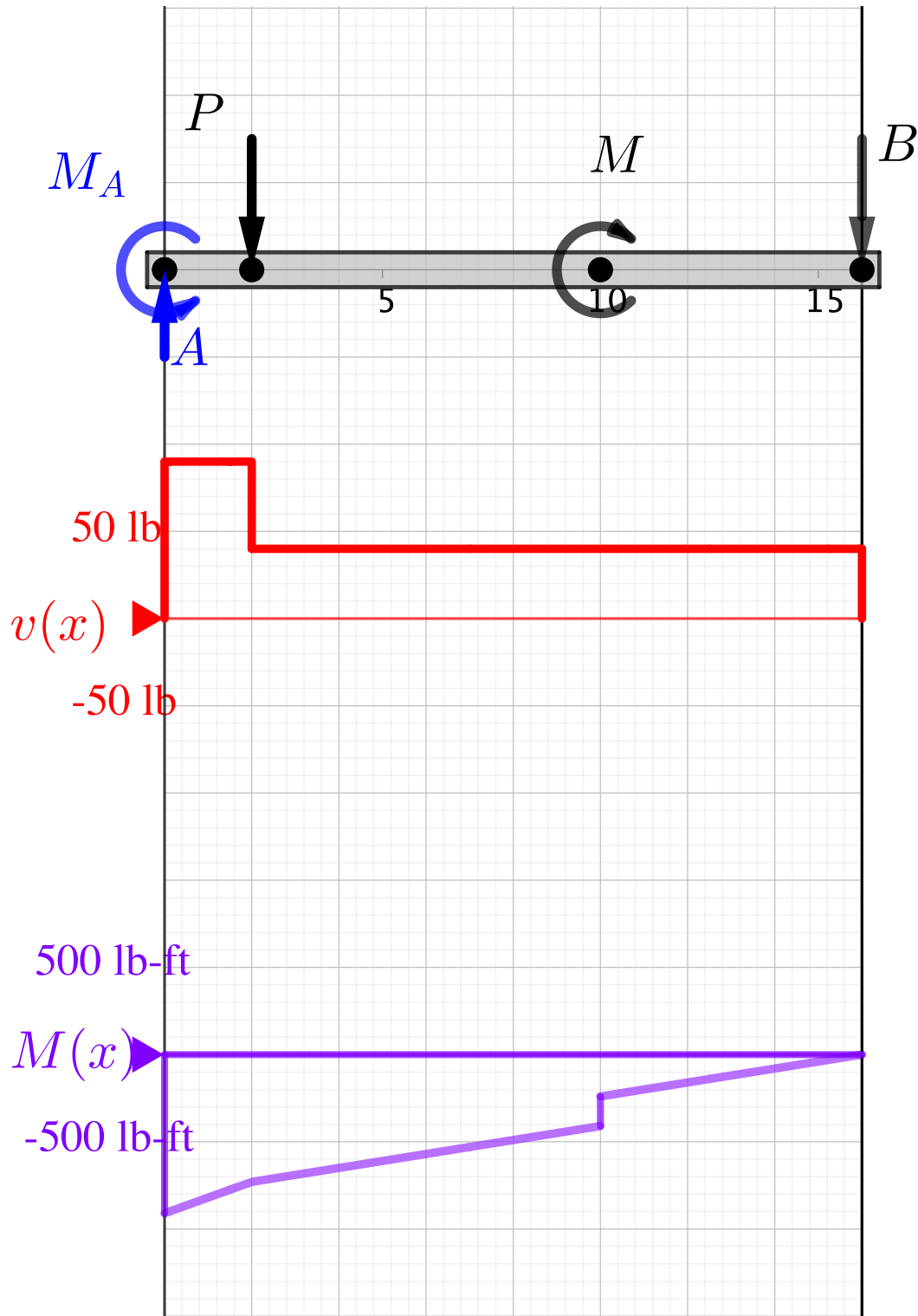



Live Link

8.9.3 Distributed Load

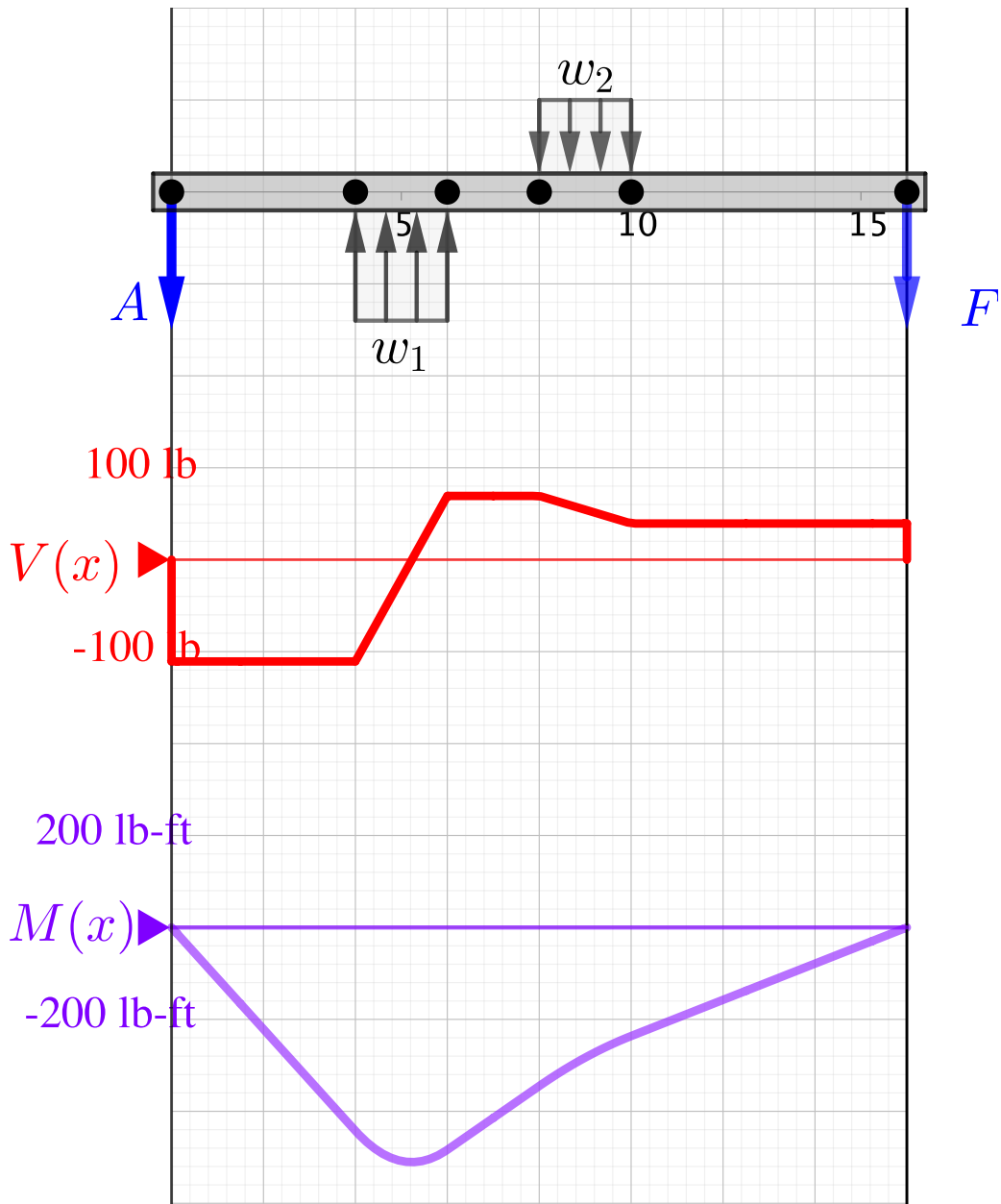

Live Link

8.9.4 Combination Load

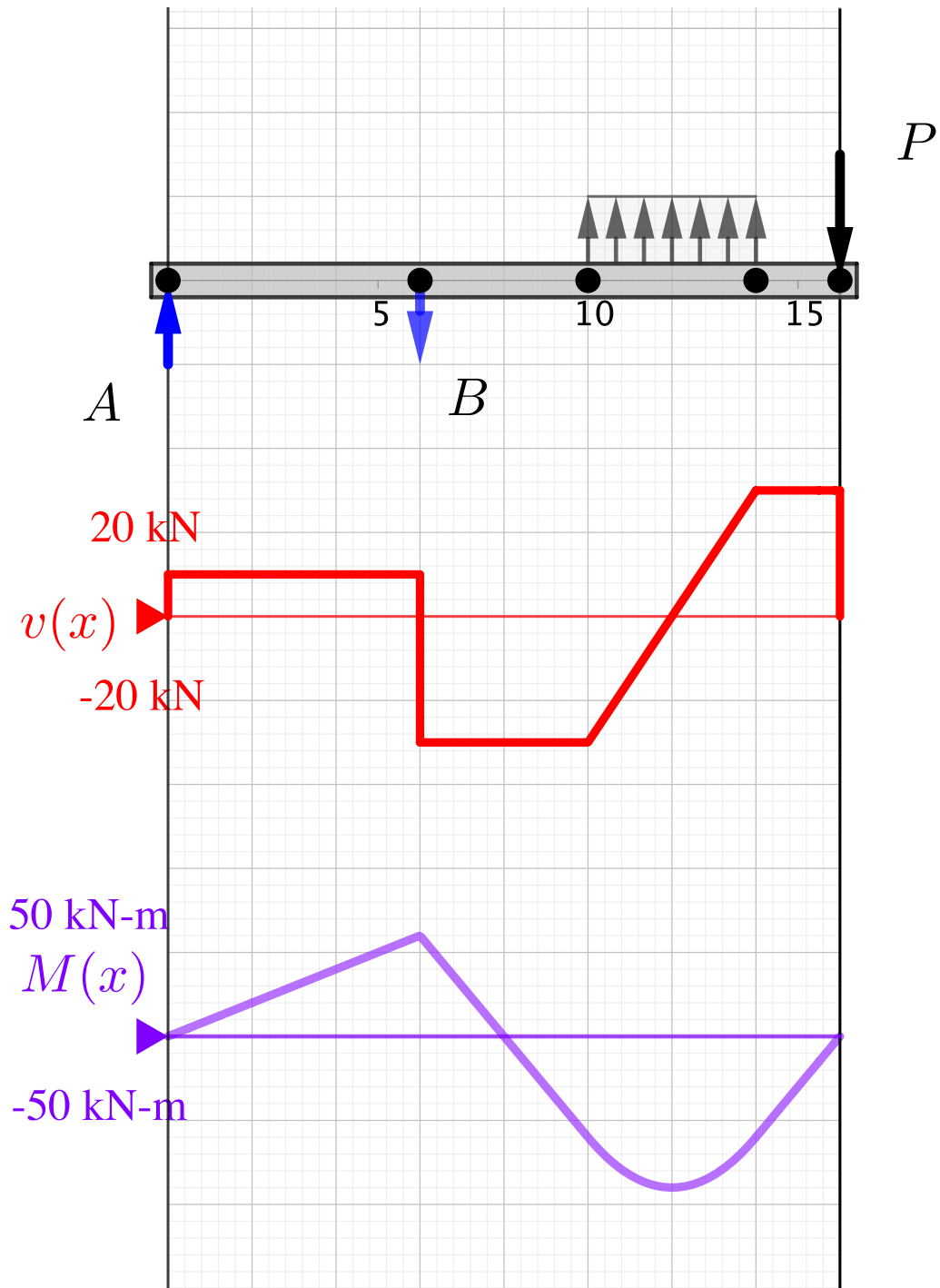

Live Link

8.9.5 Arbitrary Load

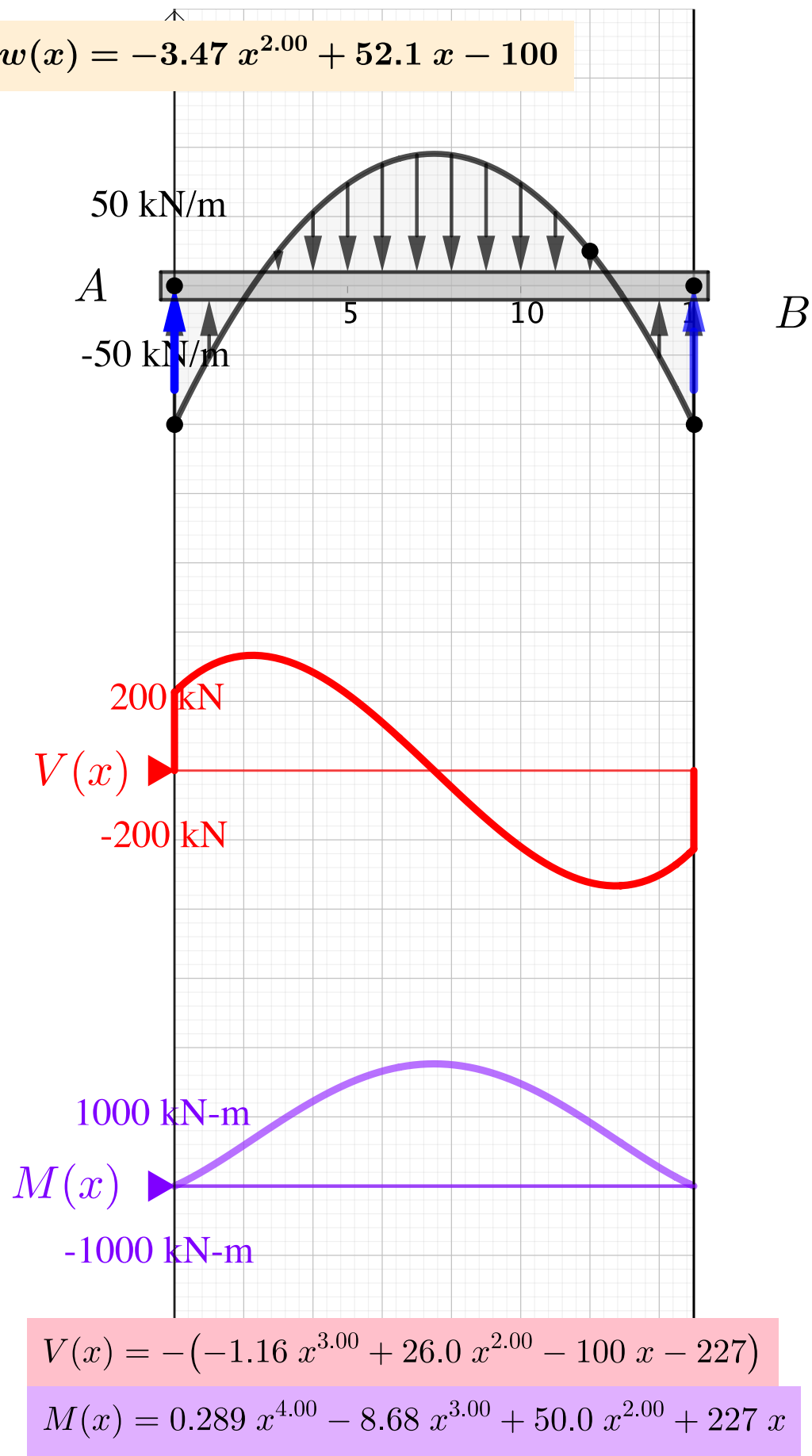

[Live Link](#)

8.10 Summary

You have likely realized that in engineering (and life) that there are multiple ways to solve a problem. The four different techniques to compute internal forces discussed in this chapter are a demonstration of this. In the end, the choice of which method to use is yours; the better you know each method the easier it will be to choose the one which is most applicable and efficient.

The list below summarizes each of the four approaches and their advantages and disadvantages.

List 8.10.1 Summary of Methods to find Internal Loadings.

- In [Section 8.3](#) we exposed the internal forces at a specific point inside a rigid body by taking a cut at that location and applying the equilibrium equations. This approach is computationally efficient, works for any rigid body and takes advantage of tools you have learned in previous chapters. It requires knowledge of sign conventions for internal shear and bending moments, but only reveals values at the selected point.
- In [Section 8.6](#) we generalized the previous approach by taking a cut at a variable location, and analyzed the equilibrium equations in terms of x . The results were *functions* which describe shear and moment at every point within the beam, rather than at a specific location. This method requires breaking a beam into loading segments and writing and solving equations for each segment. The equations are then plotted to give shear and bending moment diagrams.
- In [Section 8.7](#) we used the mathematical relationships between loading, shear, and bending moment to draw shear and moment diagrams directly. The method is quick and requires only a few simple computations to determine the critical values. The approach provides many cross-checks for accuracy. It is most suitable for beams loaded with concentrated forces, concentrated moments, and uniformly distributed loads, but is not usually suitable for more complex distributed loads. It is essential to have a solid grasp of the integral and differential relations between loading, shear and moment discussed in [Section 8.5](#) to use this method.
- In [Section 8.8](#) we discussed the most general approach to determine internal loads. In the approach, the load is described as a piece-

wise function of x , which is integrated twice to develop equations for shear and moment. This method can be used for arbitrarily complicated loading distributions, and can be used by software solutions. Applying this method by hand requires accurate integration and differentiation, and application of boundary conditions.

8.11 Exercises (Ch. 8)

Chapter 8 Exercises

Internal Forces	0/80
Distributed load V, M	0/50 Not attempted
Distributed load V, P, M	0/30 Not attempted
Shear and Bending Moment Diagrams	0/275
V&M Diagrams: Section Cut Method	0/60 Not attempted
V&M Diagrams: Concentrated Forces	0/20 Not attempted
V&M Diagrams: Concentrated Moment	0/20 Not attempted
V&M Diagrams: Distributed Loads	0/20 Not attempted
V&M Diagrams: Combined Loads	0/20 Not attempted
V&M Diagrams: Ground Beam	0/15 Not attempted
V&M Diagrams: Triangular Loading	0/20 Not attempted
V&M Diagrams: Symmetric Parabolic Loading	0/60 Not attempted
V&M Diagrams: Arbitrary Loading Function	0/40 Not attempted

Created using Numbas v9.1, developed by [Newcastle University](#)



Standalone
In Context

Chapter 9

Friction

Friction is the force which resists relative motion between surfaces in contact with each other.

Friction is categorized by the nature of the surfaces in contact and the conditions under which they are interacting. There are many different types of friction, some of which are listed below.

1. **Dry friction**, which is the force that opposes one solid surface sliding across another solid surface.
2. **Rolling friction** is the force that opposes motion of a rolling wheel or ball.
3. **Fluid friction** is the friction between layers of a viscous fluid in motion.
4. **Skin friction**, also called drag, is the friction that occurs between a fluid and a moving surface.
5. **Internal friction** is the force resisting the internal deformation of a solid material.

An understanding of friction is important factor in the design, functionality and performance of many mechanical systems. In this text we will only consider dry friction out of the many types of friction listed above. So far, we have only looked at situations where friction could be safely ignored; however, there are many cases where the effect of dry friction is significant. These include slipping or tipping, blocks, wedges, screws, belts, bearings, and rotating discs. These are the subject of this chapter.

9.1 Dry Friction

Key Questions

- Which types of friction do we study in statics, and which are studied elsewhere?
- What is a *normal* force?
- What is *impending motion*?
- How do you decide when you can use the equation $F = \mu_s N$ and when you can not?
- Can you show graphically how friction and normal force vectors are related to the friction resultant vector and the friction angle at impending motion?
- What is the friction angle ϕ_s ?
- Why is a distributed normal force represented as a point force that moves as the normal force shifts?

Dry Friction. Dry friction, also called **Coulomb friction**, is a force which appears between two solid surfaces in contact. This force is distributed over the contact area and always acts in whichever direction opposes relative motion between the surfaces. We will usually simplify the distributed frictional force by representing it as a single concentrated force acting at a point, as we did in [Section 7.8](#).

Depending on the details of the situation, dry friction will either hold the object in equilibrium, in which case it is called **static friction**, or it will retard but not prevent motion, in which case it is called **kinetic friction**.

Consider the football training sled shown in [Figure 9.1.1](#). Initially, the sled's weight is supported by a normal force acting on the bottom surface that can be considered as a point force directly beneath the center of gravity; there is no friction force.

When players begin to push the sled, a friction force will appear along the bottom surface which opposes sliding to the right. Both the friction and normal forces can be represented by concentrated horizontal and vertical forces located to the right of the center of gravity. This offset is required to maintain rotational equilibrium against the pushing force. If the players push hard enough, equilibrium will break and the sled will begin to slide in the direction of the push. At this point static friction has transitioned to kinetic friction.



(a) Training sled

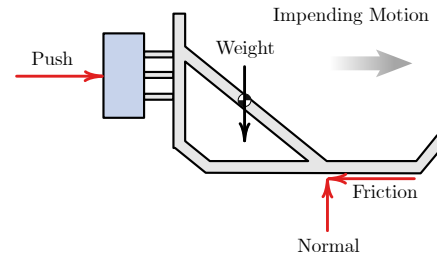

(b) Free-body diagram

Figure 9.1.1 Static friction holds an object stationary, up to the point of impending motion. Kinetic friction applies to sliding objects.

The rolling friction acting on the motorcycle in [Figure 9.1.2](#) is more complicated. Both wheels rotate clockwise, but the rear wheel is driven by the engine and chain, while the front wheel is rotated by the road friction. The friction force on the rear tire acts to the right and is what propels the bike forward. The dry friction on the front tire acts to the left and retards the motion of the motorcycle.



(a) A motorcycle

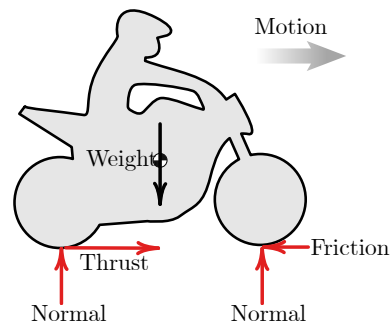

(b) Free-body diagram

Figure 9.1.2 Rolling friction occurs where the tires contact the road.

Thinking Deeper 9.1.3 Statically Equivalent Loadings.

The force distribution on the bottom of an object being pushed across a surface is complex, and looks approximately like (a).

To simplify things, we first decompose the actual force into a distributed *normal* force perpendicular to the surface, and a distributed *friction* force parallel to the surface, as shown in the (b). These two distributions are further simplified into two concentrated forces representing the normal and friction components of a single resultant force, as shown in (c). The net resultant force acts at the point required for equilibrium.

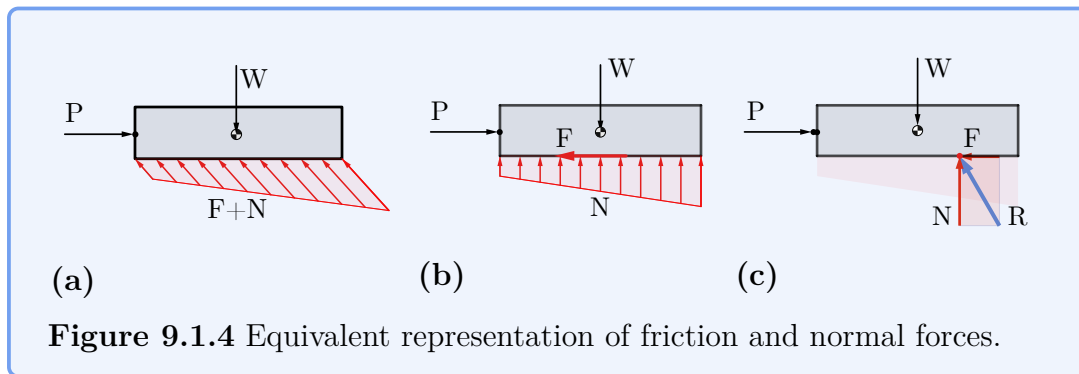

9.1.1 Coulomb Friction

The Coulomb friction model proposes that the force of friction is proportional to the normal force, where the normal force is the force acting perpendicular to the contacting surface.

$$F_f = \mu N$$

The constant of proportionality, μ , is called the friction coefficient. μ is always greater than zero and commonly less than one. The friction coefficient can be greater than one for materials that exhibit positive adhesion to each other like silicone rubber, glued surfaces, or gecko's feet.

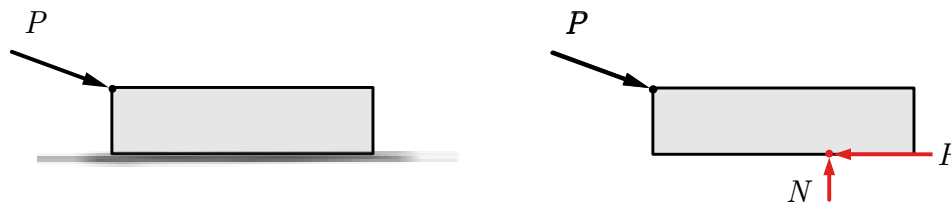

(a) Block on rough surface.

(b) FBD showing normal and friction forces.

Figure 9.1.5

Friction has two distinct regions as shown in [Figure 9.1.6](#), and the value of μ is different in each region. The region from point one to point two, where the force of friction increases linearly with load is called the **static friction** region. Here you must use the **coefficient of static friction** μ_s . The region from point two to point three, where the friction remains roughly constant is called the **kinetic friction** region. In this region you must use the **coefficient of kinetic friction** μ_k .

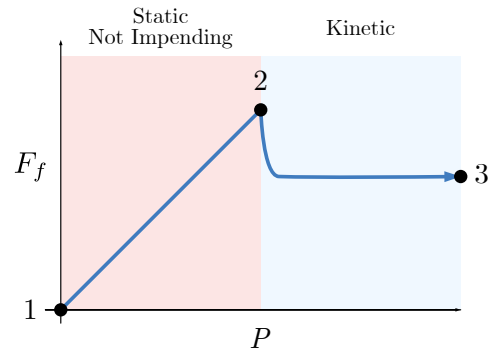

Figure 9.1.6 Phases of Coulomb friction.

The coefficient of friction suddenly drops at point two, causing the friction force F_f to drop as well. Point two is called the point of **impending motion**, because here the situation is unstable. If the applied force increases ever so slightly, the opposing friction force suddenly decreases and the object begins to move.

To better understand the behavior of Coulomb friction imagine an object resting on a rough surface as shown in [Figure 9.1.5\(b\)](#). When force P is gradually increased from zero, the normal force N and the frictional force F_f both change in response. Initially both P and F_f are zero and the object is in equilibrium. The interaction between the two surfaces in contact means that friction is available but it is not engaged $F_f = P = 0$.

As P increases, the opposing friction force F_f increases as well to match and hold the object in equilibrium. In this static-but-not-impending phase $F_f = P$.

When P reaches point two, motion is impending because friction has reached its maximum value. $F_{f_{max}} = \mu_s N = P$. If force P increases slightly beyond $F_{f_{max}}$, the friction force suddenly drops to the kinetic value $F_f = \mu_k N$. The applied force exceeds the frictional force breaking equilibrium and causing the object to accelerate, and accelerating bodies are beyond the scope of Statics!

Notice that static friction at impending motion is greater than kinetic friction, because the coefficient $\mu_s > \mu_k$ for most materials. Practically, this tells us that once a material starts to move it is easier to keep moving than it was to get it started from rest.

If you wonder why we include kinetic friction in a statics course, remember that a sliding body moving at constant velocity is in equilibrium.

9.1.2 Friction Angle and Friction Resultant

Recall that a resultant is the sum of two or more vectors. The **friction resultant** is the vector sum of the friction and normal forces. Since these two forces are perpendicular, the magnitude of the friction resultant can be found using the Pythagorean theorem.

$$R = \sqrt{F_f^2 + N^2} \quad (9.1.1)$$

The **friction angle** ϕ_s is defined as the angle between the friction resultant and the normal force. At impending motion, the friction angle reaches its maximum value. The friction resultant and friction angle are used for screw, flexible belt, and journal bearing type problems.

The maximum friction angle ϕ_s is directly related to the coefficient of static friction μ_s since the friction angle ϕ_s is the internal angle of the right triangle formed by the normal force N , the friction resultant R , and the friction force F . Hence:

$$\tan \phi_s = \frac{F}{N} \quad \phi_s = \tan^{-1} \left(\frac{F}{N} \right) \quad (9.1.2)$$

In [Figure 9.1.7](#) a block of weight W is pushed sideways by force P . The reaction forces can be represented as separate friction and normal forces, or as combined friction force R acting at friction angle ϕ_s , measured from the normal direction.

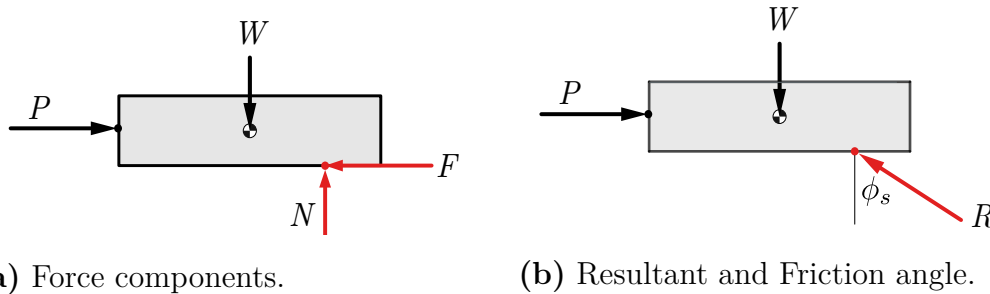

Figure 9.1.7

9.1.3 Normal Forces

The normal force supporting the object is distributed over the entire contact surface, however it is common on two dimensional problems to replace the distributed force with an equivalent concentrated force acting at a particular spot on the contacting surface, as we did in [Chapter 7](#). This point is rarely at the exact center of the contact surface.

This is illustrated in [Figure 9.1.8](#) where we see in that an object at rest has a uniformly distributed normal force along the bottom surface and the resultant normal force is located directly below the weight. The friction force is not engaged. When a pushing force F_{push} is applied, the distributed normal force changes shape, and the resultant normal force N shifts to the right to maintain equilibrium. The resultant normal force continues to shift to the right the harder you push.

This can be understood from the principle of a two-force body. As we discussed [previously](#), the combined push and weight can be represented a single load acting down and to the right. The friction and normal forces can be combined into a single reaction force acting up and to the left at a point on the bottom surface. These two forces must share the same line of action to maintain equilibrium, so as the pushing force increases, the friction angle changes and

the point shifts to the right. If the point shifts off the physical object then the required friction is greater than the friction available and motion begins.

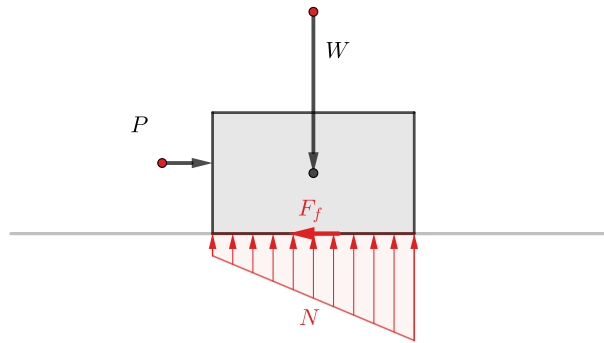

[Live Link](#)

Figure 9.1.8 Distributed Normal force changes with load and weight.

9.1.4 Coulomb Friction Examples.

Static, but not impending motion. For these problems F_f is independent of N so you will need one additional piece of data in order to solve for both F_f and N since you will not be able to apply the equation $F_f = \mu_s N$. The problem statement will use words like ‘sitting’, ‘static’ or ‘at rest’, but no extremal language like ‘maximum’. The reaction can be modeled as a pin reaction, and then possibly checked to confirm $F < \mu_s N$.

Example 9.1.9

A moment of $20 \text{ N}\cdot\text{m}$ is applied to a wheel held static by a brake arm. What is the friction force between the wheel and the brake arm?

Example 9.1.10

A box sits on a slope, find the resultant of the friction and normal forces on the box.

Impending motion. In this case, the friction force will be given by $F_f = \mu_s N$. The problem statement will mention maximum or minimum values.

Example 9.1.11

What is the maximum force applied to the box before it will start to move?

Example 9.1.12

What is the minimum coefficient of static friction that will keep the box static? What is the lightest box which will not slip or tip on this slope?

Example 9.1.13

What is the lightest box which will not slip or tip on this slope?

Kinetic friction. In these problems, $F_f = \mu_k N$. The problem statement will say that the body is moving at a constant velocity.

Example 9.1.14

A 40 kg box is sliding down a 20° slope, what is the coefficient of friction to keep the velocity constant?

Example 9.1.15

A rope slips over a surface at constant velocity, what is the contact angle of the rope?

9.2 Slipping vs. Tipping

Key Questions

- What are the possible motions which can occur when you apply a force to an object sitting on a rough surface?
- How do you determine which motion will occur in a particular situation?
- Which types of motion are beyond the scope of Statics?

This section focuses on the various ways a rigid body in equilibrium might begin to move. The point at which an object starts to move is called the point of impending motion.

The interactive in [Figure 9.2.1](#) shows a box sitting on a rough surface. Imagine that we start pushing on the side of the box with a gradually increasing

force. Initially, friction between the block and the incline will increase to maintain equilibrium, and the box will sit still.

As we continue to increase the force there are two possibilities; the maximum static friction force will be reached and the box will begin to slide, or the pushing force and the friction force will create a sufficient couple to cause the box tip on its corner.

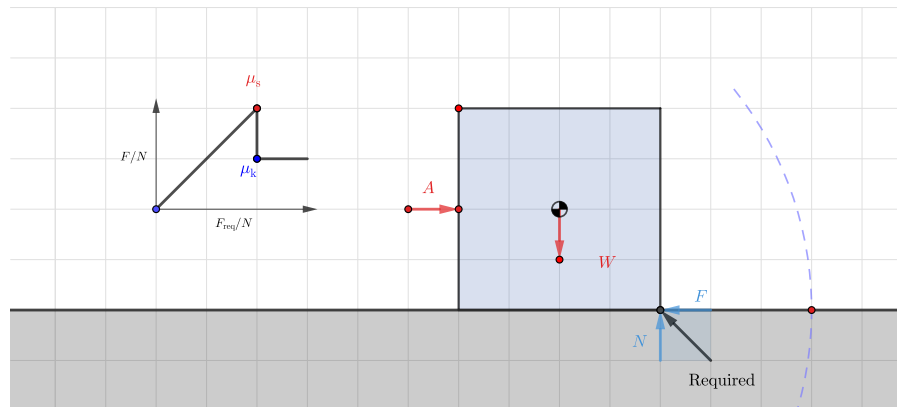

[Live Link](#)

Figure 9.2.1 Slipping vs. Tipping

The easiest way to determine whether the box will slip, tip, or stay put is to solve for the maximum load P twice, once assuming slipping and a second time expecting tipping, then compare the actual load to these maximums. This process is summarized in the following three steps:

1. Check slipping.

As in all dry friction problems, the maximum friction force is equal to the static coefficient of friction times the normal force

$$F_{f_{\max}} = \mu_s N.$$

Assume that the maximum normal force N is acting at an unknown location and solve for the applied force which will maintain equilibrium. If the load exceeds this value then this the body will slip or maybe tip.

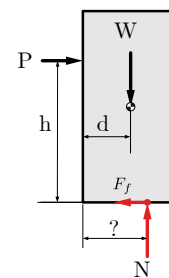

Figure 9.2.2 FBD to check slipping.

2. Check tipping.

The object will tip when the resultant normal force N shifts off the end of the object, because it no longer acts on the object so it can't contribute to equilibrium.

Create a free-body diagram assuming that the normal force N acts at the far corner of the box and solve for the applied force which will maintain equilibrium. Any greater force will make the body tip, unless it is already slipping.

At tipping, the friction force is static-but-not-impending as it has not reached impending motion for slipping.

3. Compare the results.

If P exceeds the smaller of the limiting values, it will initiate the corresponding impending motion.

Thinking Deeper 9.2.4 Failure in Engineering.

The goal of engineering design is to forecast and plan for all the ways that something can fail. The challenge is to know the questions to ask and the data to gather to model all possible failure modes. The controlling failure is the mode which occurs at the smallest load.

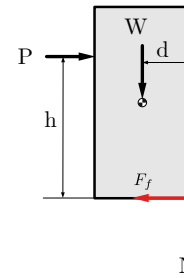

Figure 9.2.3 FBD to check tipping.

9.3 Wedges

Key Questions

- Why is the normal force always perpendicular to the contact surface while the friction force always lies parallel to it?
- Can you demonstrate graphically that components of friction and normal forces are related to the right-triangle trigonometry terms sine and cosine?

A wedge is a tapered object which converts a small input force into a large output force using the principle of an inclined plane. Wedges are used to separate, split or cut objects, lift weights, or fix objects in place. The mechanical advantage of a wedge is determined by the angle of its taper; narrow tapers have a larger mechanical advantage.

Wedges are used in two primary ways:

Low friction wedges are a simple machines which allows users to create large output forces to move objects using comparatively small input forces. In the log splitter in [Figure 9.3.1\(a\)](#), hydraulic ram pushes a log into a stationary wedge.

The normal force pushes the two halves of the log apart while the friction force F_f opposes the pushing force P .

High-friction (self-locking) wedges control the location of objects or hold them in place. Examples include doorstop wedges and carpentry wedges. The sailor in [Figure 9.3.1\(b\)](#) is hammering two wooden wedges towards each other to create large compressive forces to secure shoring timbers during a damage control operation.



(a) A low friction wedge is used to split logs.



(b) High friction wedges are used to secure shoring timbers.

Figure 9.3.1 Wedges in use.

Luckily the analysis of low- and high-friction wedges are identical and they are quite similar to the multi-force body equilibrium problems we saw in [Chapter 5](#) and [Chapter 6](#). The main difference is the inclusion of friction from all non-smooth contact surfaces. The directions of both the normal and friction forces on the free-body diagrams are defined below.

Normal forces act between bodies act perpendicular to the contacting surfaces. All normal forces on a free-body diagram should be pointing towards the body because wedges are always subjected to compression.

Friction forces are between bodies which act parallel or tangential to the contacting surfaces and are created by the microscopic or large scale roughness of the surfaces. All friction forces on a free-body diagram should be drawn pointing in the direction which resists relative motion at the point of contact.

The key added challenge of solving wedge problems is that the angled faces of wedges usually need to be resolved into components in the x and y , unless a different coordinate system is used.

One of the critical steps in solving block or wedge problems is to determine which force is engaging the friction of the system. Start by drawing the friction forces on the body where this force acts. As you pass the friction and normal forces to adjacent free-body diagrams, you must always show them as equal and opposite, action-reaction pairs. This is illustrated in the following example.

Example 9.3.2

Find the minimum force P required to start raising the 10 lb block using a 25° wedge.

Assume that the coefficient of static friction at both contact surfaces is $\mu_s = 0.20$ and that the wedge is massless.

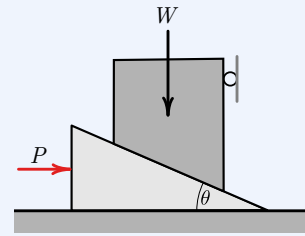

Solution. Given: $W = 10$ lb, $\mu_s = 0.2$, and $\theta = 25^\circ$.

Start by assuming the wedge is on the verge of moving to the right and drawing free-body diagrams of the system and each of its parts.

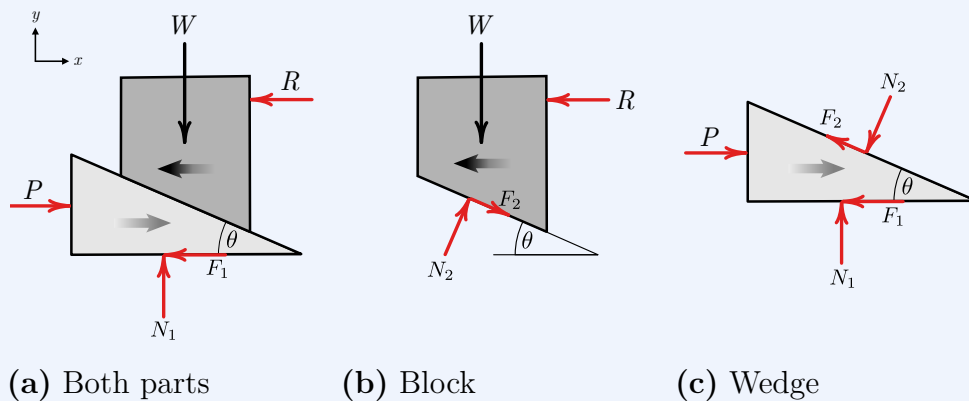

Figure 9.3.3

By considering equilibrium of the combined wedge and block in the y direction, we find that

$$N_1 = W = 10 \text{ lb}$$

Assuming that the wedge is pushed to point of impending motion,

$$F_1 = N_1 \mu_s = 2 \text{ lb.}$$

There are still two unused equilibrium equations for this free-body diagram, but they are not sufficient to find unknown forces P and R because the point where resultant friction force acts is also unknown.

Next, consider equilibrium of the block, [Figure 9.3.3\(b\)](#). A detail of N_2 and F_2 in [Figure 9.3.4](#) shows how their x and y components are related to the wedge angle θ .

Applying equilibrium in the y direction with $F_2 = \mu_s N_2$ gives

$$\begin{aligned}\Sigma F_y &= 0 \\ -W + N_{2y} - F_{2y} &= 0 \\ -W + N_2 \cos \theta - \mu_s N_2 \sin \theta &= 0 \\ N_2(\cos \theta - \mu_s \sin \theta) &= W \\ N_2 &= 12.17 \text{ lb}\end{aligned}$$

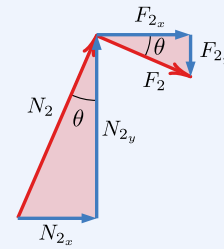

Figure 9.3.4

Since the wedge is at the point of impending motion,

$$\begin{aligned}F_2 &= \mu_s N_2 \\ &= 2.43 \text{ lb}\end{aligned}$$

With the friction and normal forces on both sides of the wedge known, we can now find the required force P using the free body diagram of the wedge 9.3.3(c).

$$\begin{aligned}\Sigma F_x &= 0 \\ P - F_1 - F_{2x} - N_{2x} &= 0 \\ P &= F_1 + F_2 \cos \theta + N_2 \sin \theta \\ P &= 9.35 \text{ lb}\end{aligned}$$

Example 9.3.5

Using the same system as in [Example 9.3.2](#), find the minimum force P' to prevent the wedge from slipping out from under the block. This is similar to the previous example, but the free-body diagrams need to change in the following ways:

- all friction force directions reverse since the impending motions of the block and wedge have reversed, and
- the direction of P' may have to reverse if the wedge has sufficient friction to stay static when $P' = 0$.

Note that for forces between P and P' , the system is static and the friction forces are static-but-not-impending.

Solution. This problem still requires a free-body diagram for each block and wedge. The only difference between it and the previous example is that the impending motion for the wedge is now to the *left*. Thus, the

friction forces on the top and bottom of the wedge are to the *right* and are both still at impending motion.

The remainder of the solution is left as an exercise for the reader.

9.4 Screw Threads

Key Questions

- Can you describe how the right-hand rule relates to the motion and rotation of screws?
- What is the thread pitch and friction angle for a screw?
- Contrast the different types of screw motion, with and against applied loads, and match the motion cases to their corresponding equation.
- Why does a screw and a nut move in relatively opposite directions?

A screw thread is uniform shape which spirals around the inside or outside surface of a cylinder or cone. Like wedges, screws are simple machines. They are essentially a ramp or inclined plane wrapped into a helix, and the input to screws is torque rather than linear force. The mechanical advantage of a screw depends on its **lead**, which is the linear distance the screw travels in one revolution.

Screws used to fix objects in place are called **fasteners**, and screws used to move objects are called **power screws** or **lead screws**. In this chapter we will focus on power screws.

A power screw assembly includes a nut with matching internal threads which fits around the screw. There are two ways that a power screw can operate based on the movement of the screw and nut. In a scissors jack, the operator rotates the threaded rod with a crank fitted to the nut on the right, which is not threaded but acts as a thrust bearing. The nut on the left moves along the stationary screw to raise the load. In the C-clamp, the nut is stationary and the screw translates through as it rotates. In either case, a small moment on the screw can cause enormous forces on the nut, with the added benefit of the force being applied at a precise location as controlled by the screw.



(a) A scissor jack uses fixed screw and a moving nut.



(b) A C-clamp screw rotates and translates through a fixed nut.

Figure 9.4.1 Power Screws

9.4.1 Screw Motion and the Right-hand rule

Most screw threads are right-hand threaded, which means they follow a right-hand rule as illustrated in [Figure 9.4.2](#). When you use your right hand to then turn a right-handed thread towards your fingertips, it will move in the direction of your thumb. When you are look at the head of a bolt and rotate it clockwise, it tightens i.e. *righty-tighty*. The reverse, *lefty-loosy*, is also true.

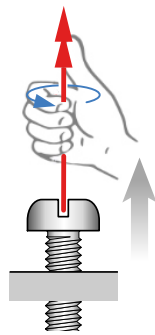

(a) Loosening

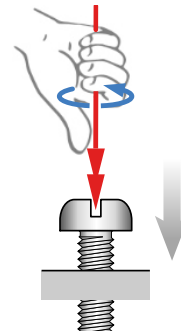

(b) Tightening

Figure 9.4.2 Right Hand Threads

Left-handed screws are less common but are found in some applications, especially:

- machines where reverse-threading prevents them from loosening gradually under the torque of the moving part. For example, the left pedal on a bicycle.

- machines where the movement of the screw creates dual motion, like a hand-screw wood clamp.
- situations where you do not want to mix up constituents. Cutting torches use right-hand thread for the oxygen and left-hand threads for the acetylene connections.

The motion of left-handed screws can either be thought of as opposite the right-hand rule or conforming to the same relationships if you use your left hand. Notice that right-handed threads slope up to the right, while left-handed threads slope down. Note that turning a thread upside-down does not reverse its handedness.

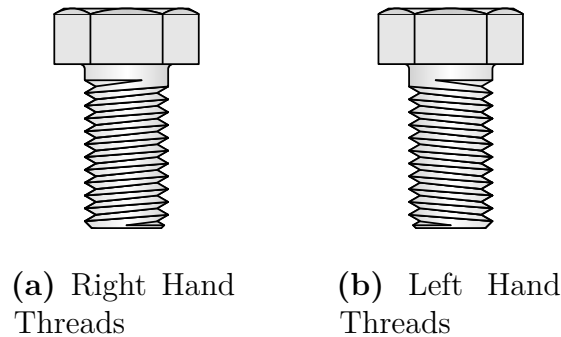

Figure 9.4.3 Screw Thread Handedness

9.4.2 Screw Thread Properties

Although most thread profiles are V-shaped, we only consider square threads in this book. General purpose thread profiles, like NPT and ISO metric are more difficult to analyze.

The easiest way to analyze a square-thread power screw system is to turn the problem into a two-dimensional problem by ‘unwrapping’ the ramp from around the cylinder of the shaft. The significant geometrical properties of the thread are

- The **mean radius**, r .
- The **lead**, l , also called the **pitch**.
- The **lead angle**, α , also called the **helix angle**.

To visualize these terms, imagine unwrapping a thread from around the screw, as shown in [Figure 9.4.4](#).

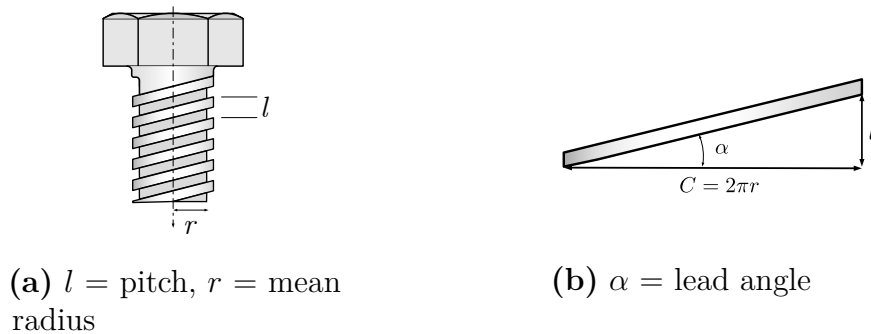
**Figure 9.4.4** Thread properties

The mean radius is the distance from the centerline to a point halfway between the tip and the root of the thread. Twice this value is the effective diameter.

The lead is the linear travel the nut makes in one revolution, which is also the distance from a point on the screw thread to a corresponding point on the same thread after one rotation. Threads are commonly designated by the number of threads per-inch or per-centimeter, and pitch is the inverse of this value.

The lead angle is related to the pitch and the mean radius by trigonometry. Using the right triangle shown in [Figure 9.4.4\(b\)](#), the thread lead angle α is the inverse tangent of the ratio of the lead over the circumference

$$\alpha = \tan^{-1} \left(\frac{l}{2\pi r} \right)$$

9.4.3 Moment to Reach Impending Motion

The focus of this section is to find the magnitude of a moment which will push a screw to impending motion. Impending motion is the threshold between the system holding still and moving, so knowledge of the moment required at impending motion allows you to interpret what happens to the screw system in static but not impending-motion conditions as well.

Assuming that motion is impending means that we can use the coefficient of static friction μ_s and the related friction angle ϕ_s . Recall from earlier in this chapter, that the friction angle ϕ_s is related directly to μ_s by the equation:

$$\phi_s = \tan^{-1} \left(\frac{F}{N} \right)$$

We now have the tools assembled to derive the relationship between a screw's geometry and the applied loads.

Applied Force Opposes Impending Motion

In this scenario we will examine the magnitude of moment M required to raise a screw to impending motion against the applied force W as shown in [Fig-](#)

ure 9.4.5(a). To eliminate any references to the orientation of the screw and force like up, down, left, or right, this type of motion will be described as “the applied force opposes impending motion.” This case occurs any time you are applying a force to an object with a screw.

The free-body diagram in Figure 9.4.5(b) shows the moment \mathbf{M} required to raise a load \mathbf{W} and the friction and normal forces acting on a slice of thread. These must be summed over the entire length of the thread to find the total friction and normal forces.



(a) Screw Jack

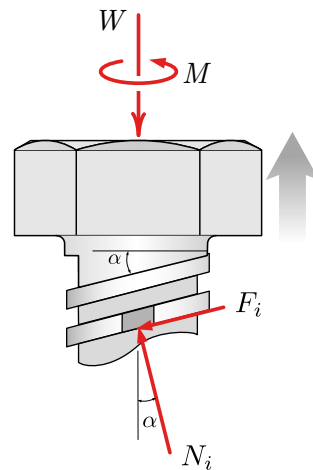

(b) FBD

Figure 9.4.5 A screw jack supports a load which opposes impending motion.

It is often easiest to express the friction force F and normal force N as the friction resultant R and the friction angle ϕ_s . Recall that the friction force F direction always opposes the impending motion of the point of contact — in this case, the screw threads. Also, the thread angle α determines the angle of the normal force N from the centerline of the screw. Finally, the friction angle ϕ_s is the angle between the friction resultant force R and the normal force N .

Figure 9.4.6 is a free-body diagram of single thread element. W_i is the fraction of the total weight on this element, and the total moment M is represented by the fraction of the rotational force P_i acting at the mean radius r from the center of the screw

$$P_i = M/r.$$

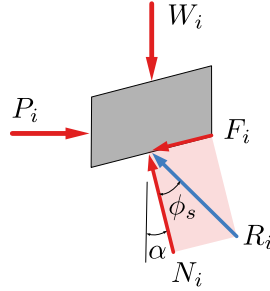
**Figure 9.4.6** FBD of Thread Element

Summing the forces in the x and y directions for the free-body diagram in Figure 9.4.6 yields:

$$\begin{aligned} \sum F_x &= 0 & \sum F_y &= 0 \\ P_i &= R \sin(\alpha + \phi_s) & W_i &= R \cos(\alpha + \phi_s) \end{aligned}$$

By summing the forces across all elements of one wrap of the screw we find:

$$\begin{aligned} \sum F_x &= 0 & \sum F_y &= 0 \\ \frac{M}{r} &= \Sigma R \sin(\alpha + \phi_s) & W &= \Sigma R \cos(\alpha + \phi_s) \end{aligned}$$

We next need to reduce these two equations to a single equation and also eliminate the difficulty to quantify ΣR term. Thus we solve both equations for ΣR .

$$\begin{aligned} \Sigma R &= \frac{M}{r \sin(\alpha + \phi_s)} \\ \Sigma R &= \frac{W}{\cos(\alpha + \phi_s)} \end{aligned}$$

Then, set them equal to each other and solve for the moment M .

$$M = W r \tan(\phi_s + \alpha) \quad (9.4.1)$$

M is the moment required to raise the screw to impending motion, W is the force load on the screw, r is the mean radius of the screw, ϕ_s is the screw friction angle, and α is the screw thread pitch.

Practically, this equation says that the moment to move a screw against an applied force must overcome the screw friction, represented by ϕ_s , and the component of the load on the screw, represented by α .

Applied Force Supports Impending Motion

When the impending motion of the screw is in the direction of the applied force, we can also state that the “applied force supports impending motion.” This case occurs any time you remove a force held by a screw, like lowering the load supported by the screw jack in [Figure 9.4.5\(a\)](#).

This situation is a bit more complicated than the previous one, because there are three different possibilities depending on the relative magnitude of the friction angle ϕ_s and the thread angle α . Cases include

1. *Self-locking.* $\phi_s > \alpha$.

In this case the load will not cause the screw to rotate by itself,

2. *Unwind-with-load.* $\phi_s < \alpha$.

In this case, the load will move the screw without assistance, and

3. *Impending motion.* $\phi_s = \alpha$.

This case is the boundary between the two other cases.

In all three cases the thread angle α is the angle between the normal force N and the centerline of the screw, and the friction angle ϕ_s is the angle between the friction resultant force R and the normal force N .

The derivations of the relationships are quite similar to the derivation of [\(9.4.1\)](#), but use subtly different free-body diagrams for each of the three cases. See [Figure 9.4.7](#) below.

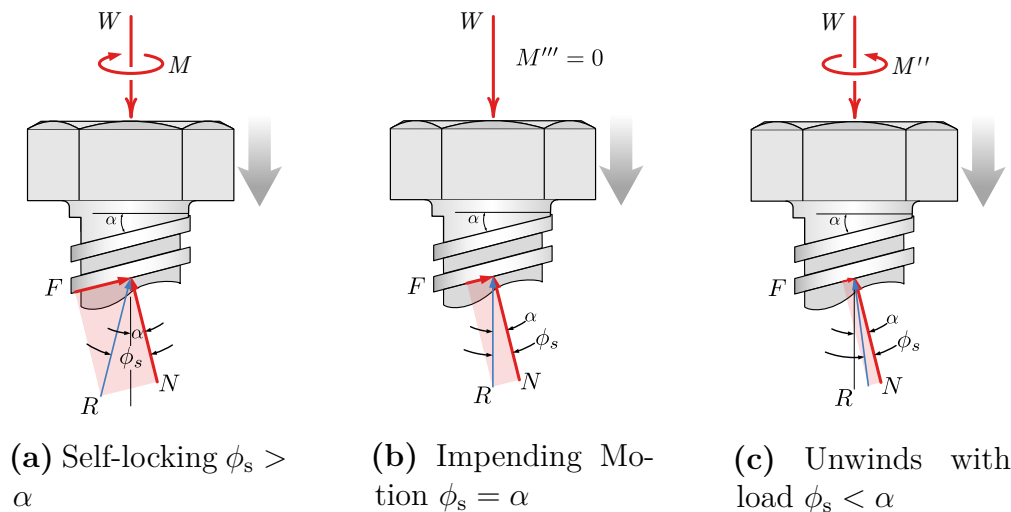

Figure 9.4.7 Three possible situations when the load acts in the direction of impending motion.

Self-locking screw. Self-locking screws are the type of screws that you will encounter most often in mechanical systems as they are highly predictable. They have sufficient friction available to hold their applied load even with no moment

applied. Thus, they can safely carry a load in a static-but-not impending condition until you wish to overcome the excess friction by applying a moment M' to push them to impending motion.

Summing the forces in the x and y directions for the free-body diagram in Figure 9.4.7(a) yields:

$$M' = Wr \tan(\phi_s - \alpha) \quad (9.4.2)$$

Unwind-with-load screw As its name implies, an unwind-under-load screw will start turning unless a moment M'' is applied to keep the screw at or beyond impending motion. The moment to push a self-locking screw to impending motion M' is in the opposite direction as the moment to keep unwind-under-load screws at impending motion M'' , as M'' is in the same direction as the moment to loosen (or raise) a screw. These unwind-with-load screws are not often found in mechanical systems, except for in dynamic motion control systems, where the screw is used to slow down motion.

To be designed in an unwind-with-load condition, a screw must have a quite steep thread angle α and minimal friction between the threads and nut, which reduces ϕ_s .

Summing the forces in the x and y directions for the free-body diagram in Figure 9.4.7(c) yields:

$$M'' = Wr \tan(\alpha - \phi_s) \quad (9.4.3)$$

Impending-motion screw As the derived equations for all three unwind-with-load screw cases push the screw towards impending motion, when a screw is already at impending motion, it requires no applied moment to maintain equilibrium; however, this case is mechanically unstable. If the load increases slightly the screw will begin to unwind-under-load, whereas if the load decreases slightly the screw will become self-locking.

Summing the forces in the x and y directions for the free-body diagram in Figure 9.4.7(b) yields:

$$M''' = 0 \text{ when } \phi_s = \alpha \quad (9.4.4)$$

The concept of an applied force in the direction of impending motion works equally well for either a force applied in the impending motion direction of a screw, or for a force applied to the impending motion direction of a nut. An example of the first case is the screw jack lowering a load, and the second could be a scissors jack that has a rotating but non-translating screw, plus a non-rotating but translating nut.

9.5 Flexible Belts

Key Questions

- How does the impending motion of the system determine which side of the belt will have a larger tension?
- How do you compute the contact angle β between the belt and pulley or cylinder?
- How do you compute the tension differential on either side of the belt or cylinder for both flat and v-belts?
- What determines the maximum torque transfer available from a pulley system?

When a belt, rope, or cable is wrapped around an object, there is potential for flexible belt friction. In [Figure 9.5.1\(a\)](#) friction allows the sailors to control the speed that the mooring line pays out. The friction between the line and the bollard depends on the number of turns the line takes around the bollard post. In [Figure 9.5.1\(b\)](#) friction forces prevent the belt from slipping allow it to transfer power from the motor to the drive pulley.



(a) Sailors handling a mooring line.



(b) Power transmission pulleys.

Figure 9.5.1 Applications of belts.

9.5.1 Frictionless Belts

Imagine with a flat, massless cable or belt passing over a frictionless cylinder or pulley, in equilibrium. (Figure 9.5.2). A non-uniform distributed normal force acts at points of contact with the cylinder to oppose the tension in the belt and maintain equilibrium. The normal force varies as a function of the angle between the contact surface and the direction the belt tension.

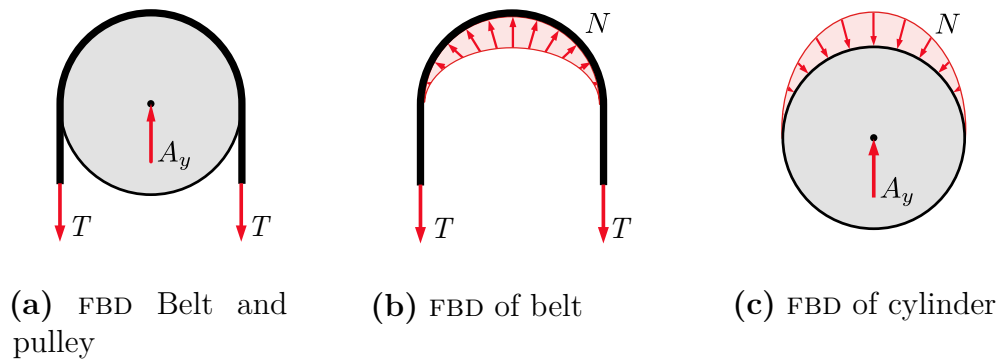

Figure 9.5.2 Free-body diagrams, equal tension.

Without friction, the two tensions must be equal otherwise the belt would slip around the cylinder. The only interaction force between the belt and pulley is the distributed normal force. Due to the symmetry of this example, the x components of the distributed force all cancel and the resultant is purely vertical. In other situations this will not be true.

9.5.2 Friction in Flat Belts

When friction is available to oppose the sliding, the tensions in the two sides of the belt will not be equal and friction will cause the pulley to rotate. Alternately if the pulley is driven by an external moment, friction will cause one tension to increase and the other to decrease. This, of course, is the point of a belt and pulley system — power transmission from the belt to the pulley or vice-versa.

Figure 9.5.3(a) shows a free-body diagram of a belt and pulley in equilibrium. The net moment caused by the two belts and the applied moment M are in balance. The system may be stationary, or it may be rotating at a constant velocity; however, it is impossible to tell from this diagram which direction.

Figure 9.5.3(b) shows a free-body diagram of the belt. Since T_+ is greater than T_- , in the absence of friction, the left side will move up, and the right side will move down, as indicated by the arrows which indicate the relative motion of belt with respect to the pulley. A distributed friction force F_{belt} between the belt and pulley which opposes the relative motion and maintains rotational equilibrium. A distributed normal force also exists to maintain equilibrium in the y direction.

Figure 9.5.3(c) shows a free-body diagram of the pulley. The frictional and normal forces acting on the pulley are equal and opposite to those acting on the

belt. The arrow indicates that the impending relative motion of the pulley with respect to the belt is counter-clockwise. The actual direction of rotation is not known or indicated. Friction always acts opposite to the direction of relative motion.

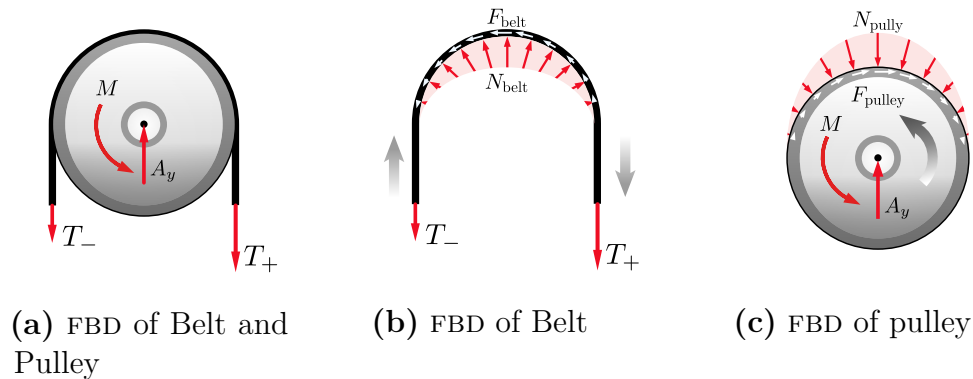

Figure 9.5.3 Unequal Tensions

Increasing M or the belt tension ratio T_+/T_- will increase the power transmitted until the belt starts to slip. This occurs when the friction increases to the maximum available value $F_{\max} = \mu_s M$. At this point, motion (slipping) is impending.

We are interested in determining the range of values for the tension forces where the belt does not slip relative to the surface. For a flat belt, the maximum value for T_+ depends on the magnitude of T_- , the static coefficient of friction between the belt and the surface μ_s , and the contact angle β between the belt and the surface.

Contact Angle β

You will need to use the geometry of the pulleys to find the contact angle β between the belt and pulley. The belt will depart the pulley at a point of tangency, which is always perpendicular to a radius. To find β create one or more right triangles using the incoming and outgoing belt paths and apply complementary angles to relate the belt geometry to the contact angle. There is no simple rule for transferring cable angles over to the contact angle, but in general, extend radial lines from the center of the pulley out to the belt's tangential lines. Next, create right triangles with each radial line and work to find all the angles which add up to the contact angle β .

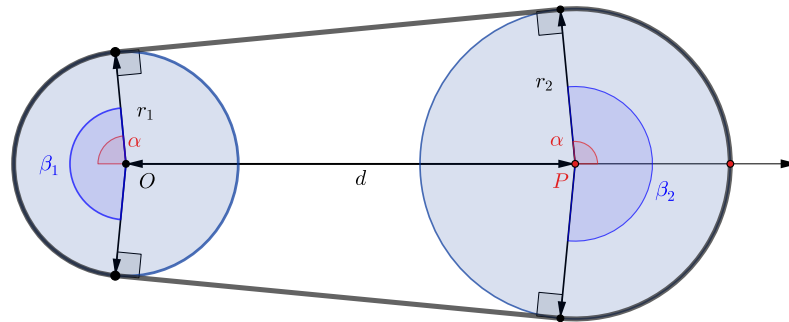

[Live Link](#)

Figure 9.5.4 Relationship between pulley geometry and contact angle β .

Belt Tension

We have seen that when there is friction between a belt and a pulley, the tensions on either end of the belt are not the same. In previous problems, we simply guessed a direction for an unknown force, and then used the sign of the numerical answer to confirm or reverse our assumption. Unfortunately, this does not work for flexible belts, where we must make the correct determination before starting computations. So, how can we determine which side has the larger tension, and which side is smaller?

The following discussion guides you through two methods to make this decision. [Figure 9.5.5](#) shows a pulley and belt system and the associated free body diagrams. The pulley is driven by a motor which supplies a counterclockwise moment of M . The belt is fixed, and holds the pulley in equilibrium until slipping occurs. Both the pulley and belt are assumed massless.

The grey arrows indicate the direction of *impending* motion. This is the motion which will occur if the belt slips. For the belt, which is fixed, this impending motion is *relative* to the pulley. For the pulley, motion is impending *relative* to the belt, but since it can actually rotate it also has *absolute* impending motion with respect to the earth.

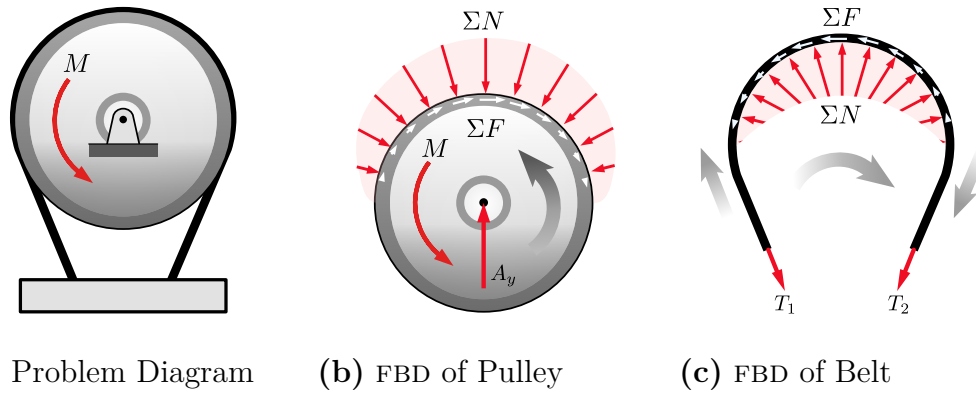

(a) Problem Diagram (b) FBD of Pulley (c) FBD of Belt

Figure 9.5.5 Motor drive pulley with a fixed belt.

1. *Method 1: Draw free-body diagrams and sum tensions along the cable.*

Friction always opposes impending relative motion at the point of contact, so if you can determine the direction the belt will potentially slip, you also know the direction of the friction force. You can find out which tension is larger and which is smaller by drawing a free-body diagram of the belt and summing forces along it.

The free-body diagram [Figure 9.5.5\(b\)](#) shows the forces acting on the pulley, which are:

- Reaction force A_y from the fixed center axle.
- A distributed normal force ΣN acting radially along the contact surface with the belt.¹
- A distributed friction force ΣF acting along the contact surface, opposing moment M and the impending motion of the pulley.

The free-body diagram [Figure 9.5.5\(c\)](#) shows the forces acting on the belt, which are:

- The belt's internal tension forces, labeled T_1 and T_2 since at this point we don't know their relative magnitudes.
- A distributed normal force ΣN acting radially along the contact surface between the pulley and belt. These are the distributed normal forces on the pulley transferred equal-and-opposite to the belt.
- A distributed friction force ΣF acting along the surface of the belt, again equal-and-opposite to the corresponding forces on the pulley. Since the belt is not actually moving these forces oppose the belt's *relative impending motion* with respect to the pulley.

¹The distributed normal forces is not symmetrical as drawn, but actually biased towards the right, in order to have the net leftward force required to oppose the net friction acting to the right. Fortunately, the actual shape is not significant to us.

Summing forces along the belt, we find that the tension T_1 plus the distributed friction force ΣF must equal T_2 for equilibrium.

$$\begin{aligned}\Sigma F_{\text{belt}} &= 0 \\ T_1 + \Sigma F - T_2 &= 0 \\ T_2 &= T_1 + \Sigma F\end{aligned}$$

Therefore, the larger tension $T_+ = T_2$ and the smaller tension $T_- = T_1$.

2. *Method 2: Larger tension acts in the direction of the impending motion of the belt.*

Following the logic of Method 1, it turns out that the larger tension always points in the direction of impending motion of the belt. It does not matter if the impending motion is relative as here with a fixed belt, or absolute as when the belt moves around a fixed object.

There are multiple ways to determine the smaller and larger tensions in a flexible belt system. You can use the interactive below to develop your intuition on the relationship between belt tension, pulley moment, friction and relative motion.

Change in Belt Tension due to Friction

Applying the equilibrium equations to a free-body diagram of a differential element of the belt enables us to derive the relation between the two belt tensions, the contact angle β , and the friction coefficient μ_s .

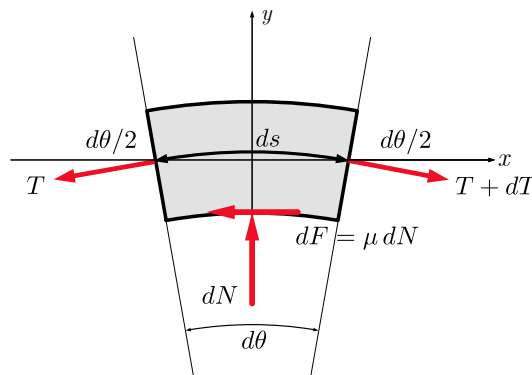

Figure 9.5.6 FBD of a differential element of a flexible belt.

Summing the forces in the x direction gives

$$\begin{aligned}\Sigma F_x &= 0 \\ \mu dN + T \cos(d\theta/2) &= (T + dT) \cos(d\theta/2) = 0 \\ \mu dN &= dT \cos(d\theta/2)\end{aligned}$$

As $d\theta$ approaches zero, $\cos(d\theta/2)$ approaches one, so in the limit,

$$dN = \frac{dT}{\mu}$$

And summing forces in the y direction gives

$$\begin{aligned}\sum F_y &= 0 \\ dN &= T \sin(d\theta/2) + (T + dT) \sin(d\theta/2) \\ dN &= (2T + dT) \sin(d\theta/2) \\ &\approx 2T(d\theta/2) + dT(d\theta/2)\end{aligned}$$

where we have used the small angle approximation $\sin(d\theta/2) \approx d\theta/2$. Dropping the second order differential term $dT d\theta$ as negligible, yields

$$dN = Td\theta.$$

Solving simultaneously by eliminating dN leaves us with

$$\frac{dT}{T} = \mu d\theta,$$

which we can integrate between T_- and T_+ to find

$$\begin{aligned}\int_{T_-}^{T_+} \frac{dT}{T} &= \mu \int_0^\beta d\theta \\ \ln \frac{T_+}{T_-} &= \mu\beta\end{aligned}$$

Integrating both sides gives:

$$\frac{T_+}{T_-} = e^{\mu\beta}, \quad (9.5.1)$$

where e is the natural log base 2.718, μ is the friction coefficient between the belt and pulley, and β is the contact angle between the belt and pulley in radians. The larger this ratio is, the more torque the belt can transmit.

Notice that the belt tension ratio is independent of the surface size and shape, provided the belt makes continuous contact.

Example 9.5.7 Rope Friction.

How much force is necessary to support a 100 lb weight suspended by a rope wrapped four and half times around a horizontal bar? Assume the coefficient of friction $\mu \approx 0.23$.



Solution. Apply (9.5.1) with $\mu = 0.23$ and $\beta = 4.5 \times (2\pi) = 28.27$ radians.

$$\frac{T_+}{T_-} = e^{\mu\beta}$$

$$T_- = \frac{100 \text{ lb}}{e^{0.23 \times 28.27}}$$

$$= 0.15 \text{ lb}$$

9.5.3 Torque in Belt Systems

A belt-driven system consists of an input pulley driven by a rotational power source and one or more output pulleys driving loads. The maximum torque that can be transmitted by the system is determined by the maximum value for T_+ before slipping occurs at either the input or any output pulley. We will need to consider each of the pulleys independently.

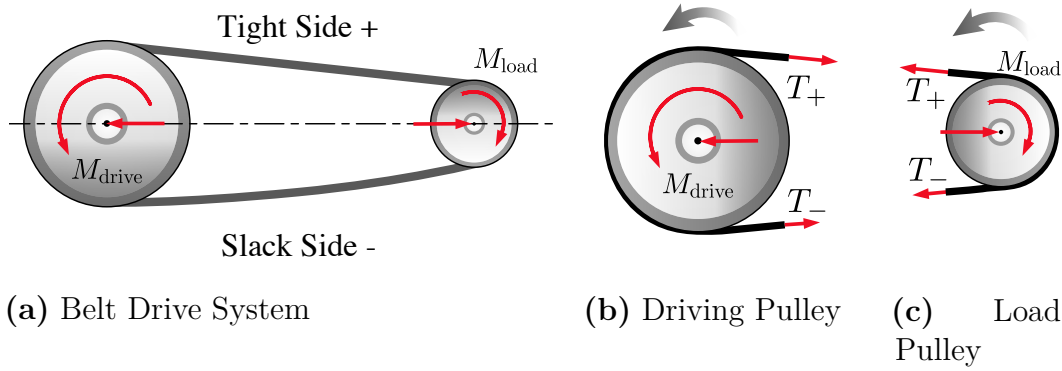
**Figure 9.5.8** Unequal Tensions

Start by solving for the resting tension T_- . This is the tension the belts prior to any motion or power transfer. Practically, machines provide adjustments to pre-tension the belt to insure sufficient normal force when started. When we turn on the machine and increase the torque, the resting tension remains constant while the tension on the drive side T_+ increases.

If the pulleys have the same coefficients of friction, it can be assumed that the belt will first slip at the smaller of the two pulleys as the smaller pulley has a smaller contact angle β . See [Figure 9.5.4](#).

Once we have the maximum value for T_- , we can use that to find the maximum input and output moments. Next, to find the torque, we then find the net moment exerted by the two tension forces, where the radius of the pulley is the moment arm.

The maximum input torque M_i before slipping is

$$M_i = (T_{+\max} - T_-)r_i$$

The maximum output torque M_o before slipping is

$$M_o = (T_{+\max} - T_-)r_o$$

In a rotating shaft, power is equal to the torque times the angular velocity in radians per second.

$$P = T\omega, \quad (9.5.2)$$

so

$$P_{\max} = M_i(\omega_i) = M_o(\omega_o). \quad (9.5.3)$$

Unlike the torque which steps up or down based on the pulley radii, the input and output powers are equal to each other, ignoring all efficiency losses.

9.5.4 V-Belts

A flat belt pulley interacts with one surface of the belt. A V shaped pulley allows the belt to wedge tightly in the groove, increasing friction and torque transmission. A V-belt's enhanced friction comes from the increased normal forces which are a function of the groove angle α .

The sum of the normal force vertical components is the same for a flat belt or V-belt. However, the horizontal components of the normal forces in a V-belt, effectively pinch the belt, thereby increasing the available friction force. The belt should not contact the bottom of the groove, or else the wedge effect is lost

$$\frac{T_+}{T_-} = e^{\left(\frac{\mu_s \beta}{\sin(\alpha/2)}\right)}. \quad (9.5.4)$$

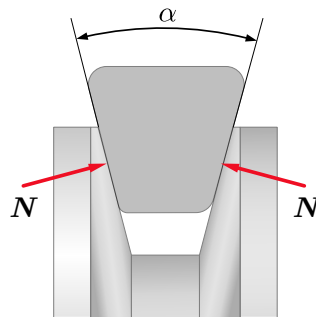

Figure 9.5.9 V-belt and pulley cross section.

As we can see from the equation above, smaller groove angle and steeper sides result in a larger maximum tension ratio, resulting in higher torque transmission. The trade-off with steeper sides, however, is that the belt becomes wedged more firmly in the groove and requires more force to unwedge itself as it leaves the pulley. This unwedging force decreases the efficiency of the belt-driven system. An alternate design choice would be a chain-drive which carries very high-tension differences efficiently.

9.6 Journal Bearings

Key Questions

- Why does the point of contact between a shaft and a journal bearing shift as the shaft rotates?
- Why is the resultant contact force tangent to the friction circle?
- Can you draw appropriate free-body diagrams of journal bearing systems and solve for unknown values?

9.6.1 Journal Bearing Friction

A bearing is a machine element used to support a rotating shaft. Bearing friction exists between the rotating shaft and the supporting bearing. Though other types of bearings exist including, ball, roller and hydrodynamic, we will focus on *dry friction* journal bearings. Oil lubricated journal bearings require a knowledge

of fluid mechanics to analyze, while dry journal bearings have point contact between the shaft and bearing and thus can be analyzed in Statics, they are subject to greater wear and heat build-up than other types of bearings; thus, the use of dry journal bearings is only advisable in situations where there is limited motion.

9.6.2 Rotating Shaft and Fixed Bearing

A dry friction journal bearing consists circular bearing surface which supports a rotating or stationary shaft. The support force acts at the single point of tangency of the two circular surfaces. The bearing prevents shaft motion in the radial directions but does not prevent axial motion due to shaft thrust.

Figure 9.6.1 shows a journal bearing supporting a shaft with a vertical load P . Initially the contact point is located directly below the load along its line of action. When a clockwise moment M is applied to rotate the shaft, friction between the shaft and bearing causes the surfaces to stick together, and the shaft climbs up the bearing surface until impending motion is reached and slipping occurs. Similarly, when a CCW moment M is applied, the contact point will shift to the left.

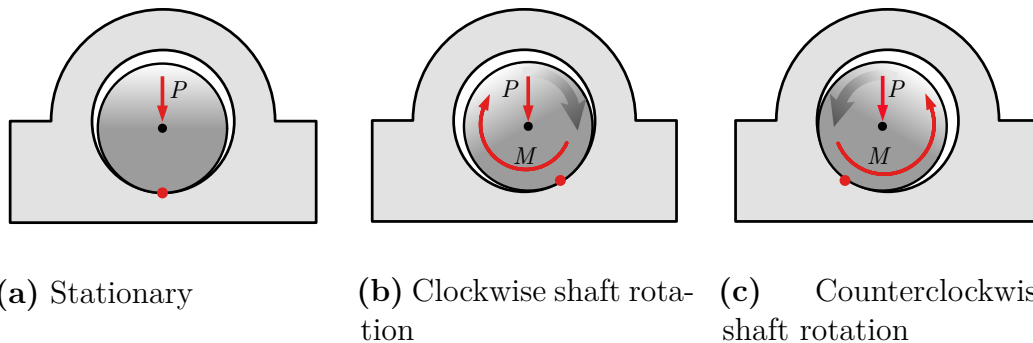

Figure 9.6.1 Contact Point Shifts against the direction of relative motion of the shaft with respect to the bearing.

Free-body diagrams for the shaft in the three cases are shown in Figure 9.6.2. At the contact points we see a normal force N and a friction force F which can be resolved into a single vertical resultant force R . Normal forces are perpendicular to shaft at the contact point, which makes their lines of action pass through the center of the shaft. When no moment is applied, no friction exists, but in the other two cases, friction creates a moment $M' = Fr_f$ about the center of the shaft which opposes the applied moment M .

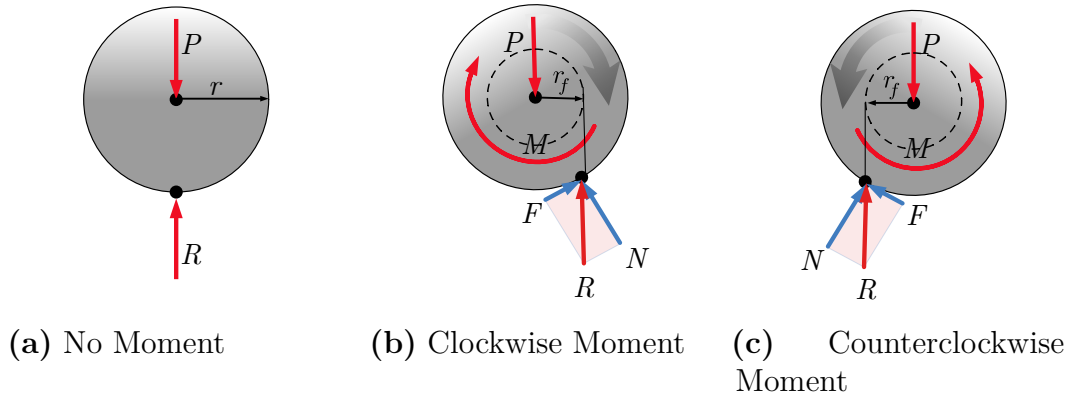

Figure 9.6.2 Shaft Free-body Diagrams

The most straightforward process to relate the load, normal and friction forces for a journal bearing is by performing the following steps:

1. Assume that the shaft and bearing opening have the same radius, but draw the shaft a bit smaller to emphasize the contact point at the point of tangency.
2. Combine the normal and friction forces into a single friction resultant force

$$\mathbf{R} = \mathbf{F} + \mathbf{N}.$$

3. Determine the radius of the friction circle, r_f , which is a circle around the center tangent to the friction resultant R . The friction circle radius is a function of the shaft radius r and the friction angle ϕ_s .

$$r_f = r \sin \phi_s = \tan^{-1} F/N.$$

4. Finally, draw a free-body diagram of the shaft with all applied loads and the friction resultant R , then solve the equations of equilibrium to find the unknowns.

9.6.3 Fixed Shaft and Rotating Bearing

Another type of journal bearing is designed with a fixed shaft and a rotating bearing. While the solution process is quite similar to the process covered above, the main difference is that you will draw a free-body diagram of the rotating bearing instead of the shaft.

Figure 9.6.3 shows the diagrams for a journal bearings with a fixed shaft and rotating bearing.

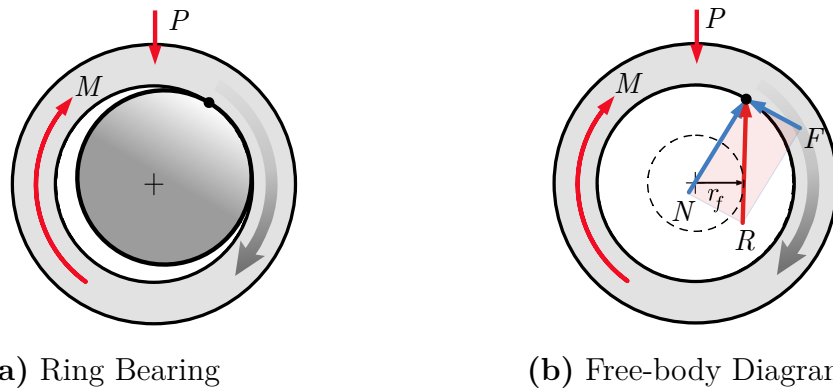

(a) Ring Bearing

(b) Free-body Diagram

Figure 9.6.3**Thinking Deeper 9.6.4 Contact Point Shift.**

In this section we saw that the contact point shifts in the direction of the relative impending motion of the bearing or opposite to the relative motion of the shaft; This is true for dry friction bearings, but with oil lubricated bearings, the shaft starts by a shift this way, but as the shaft speed increases a *hydrodynamic oil wedge* forms which shifts the shaft in the other direction in much the same way that a water skier lifts up and skims the water at high speeds.

9.7 Rotating Discs**Key Questions**

- Select the appropriate disc friction equation among those for hollow circular areas, solid areas, and disc brakes with a circular arc and
- Compute the possible moment the friction forces from disc friction can resist.

9.7.1 Disc Friction

Disc friction refers friction between a flat, rotating body and a stationary surface. Disc friction exerts a moment on the bodies involved which resists the relative rotation of the bodies. Disc friction is applicable to a wide variety of designs including end bearings, collar bearings, disc brakes, and clutches.



Figure 9.7.1 This orbital sander rotates a circular sanding disc against a stationary surface. The disc friction between the sanding disc and the surface exert a moment on both the surface and the sander.

9.7.2 Collar Bearings

A collar bearing, shown in [Figure 9.7.2](#) has a rotating annular area in contact with a stationary bearing surface. The rotating shaft passes through a hole or bearing in the surface to maintain radial alignment. The collar bearing prevents axial motion and acts as a **thrust bearing** to transfer the axial load to a solid foundation.

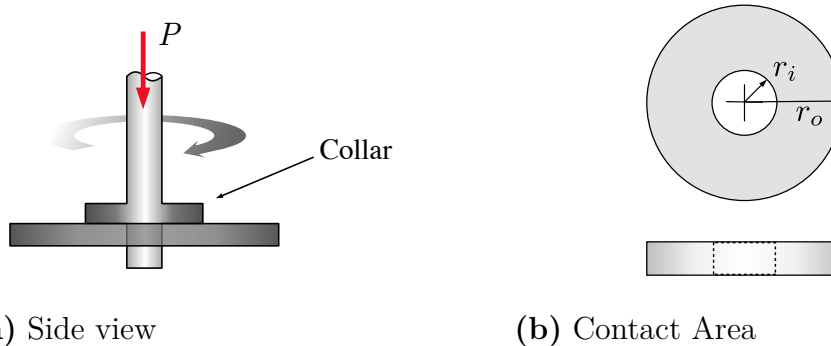
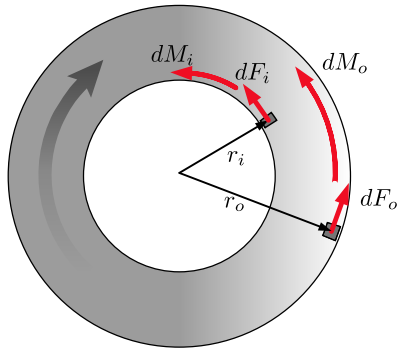

Figure 9.7.2 Collar bearing

The friction force at any point of the contact area will equal the normal force at that point times the kinetic coefficient of friction at that point. If the coefficient of friction and the pressure between the collar and the surface is the same at all points, then the same friction force at every point is the same as well. This does not mean that the moment exerted at every point is equal as well. Elements towards the outside of the contact area cause larger moments than those closer to the center since they have larger moment arms.



$$\begin{aligned}dF_f &= \mu_k dF_N \\dF_i &= dF_o \\r_i &< r_o \\dM_i &< dM_o\end{aligned}$$

Figure 9.7.3 Forces and moments on differential areas

The total moment exerted acting on the disc due to the friction forces is found by integrating the elements dM over the contact area. The moment of each element will be equal to the product of the coefficient of kinetic friction, the normal force pressure, the moment arm and the area of each element

$$dM = \mu_k p r dA.$$

$$\begin{aligned}M &= \int_A dM \\&= \int_A \mu_k p r dA\end{aligned}$$

The coefficient of friction and pressure terms are constant so can be moved outside the integral, and since pressure is defined as force per unit area $p = F/A$, the pressure term can be replaced with the applied load divided by the bearing contact area,

$$p = \frac{P}{\pi(r_o^2 - r_i^2)}.$$

A differential element of area dA can be expressed in terms of radial distance r allowing us to integrate with respect to r .

$$dA = 2\pi r dr,$$

Making these substitutions leads to an equation that is easy to integrate.

$$\begin{aligned}M &= \mu_k p \int_A r dA \\&= \mu_k \left(\frac{P}{\pi(r_o^2 - r_i^2)} \right) \int_{r_i}^{r_o} r (2\pi r) dr \\&= \frac{2\mu_k P}{(r_o^2 - r_i^2)} \int_{r_i}^{r_o} r^2 dr\end{aligned}$$

Integrating this integral, evaluating the limits and simplifying gives the final result

$$M = \frac{2}{3} \mu_k P \left(\frac{r_o^3 - r_i^3}{r_o^2 - r_i^2} \right). \quad (9.7.1)$$

9.7.3 End Bearings

In cases where we have a solid circular contact area such as with a solid circular shaft, an end bearing, or the orbital sander shown in [Figure 9.7.1](#) we simply set the inner radius to zero and simplify equation (9.7.1). If we do so, the result is

$$M = \frac{2}{3}\mu_k F r_o. \quad (9.7.2)$$

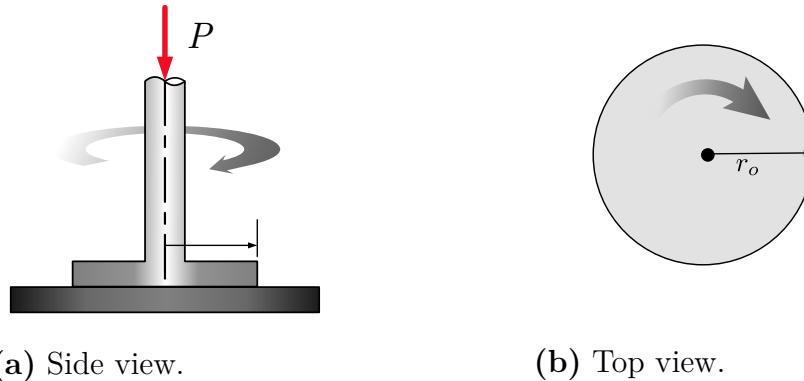

Figure 9.7.4 A circular thrust bearing.

9.7.4 Circular Arc Bearings

Automobile disc brakes have a contact area that looks like a section of the hollow circular contact area we covered earlier.

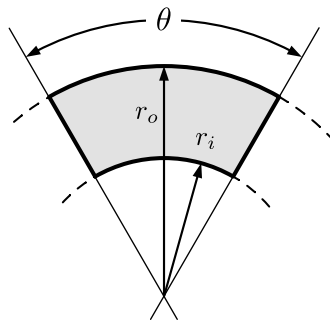

Figure 9.7.5 The contact area in disc brakes is often approximated as a circular arc with a contact angle θ .

Disc brakes, due to their smaller contact area, have higher pressure for the same applied force but a smaller area over which to exert friction. In the end, these factors cancel out and we end up with the same formula we found in [Subsection 9.7.2](#). Notice that this formula is independent of θ .

Brake pad on one side:

$$M = \frac{2}{3}\mu_k P \left(\frac{r_o^3 - r_i^3}{r_o^2 - r_i^2} \right) \quad (9.7.3)$$

Most disc brakes, however, have two pads one on each side of the rotating disc, so we will need to double the moment if so.

Brake pads on each side:

$$M = \frac{4}{3}\mu_k P \left(\frac{r_o^3 - r_i^3}{r_o^2 - r_i^2} \right) \quad (9.7.4)$$

9.8 Exercises (Ch. 9)

Chapter 9 Exercises

0/140

Friction: Block on Incline	0/20
Not attempted	
Friction: Rope around a cylinder	0/10
Not attempted	
Friction: Determine direction of F_f	0/30
Not attempted	
Friction: Range of values 1	0/20
Not attempted	
Friction: Range of values 2	0/20
Not attempted	
Friction: block on block 1	0/20
Not attempted	
Friction: block on block 2	0/20
Not attempted	

Created using [Numbas v9.1](#), developed by [Newcastle University](#).



Standalone
In Context

Chapter 10

Moments of Inertia

Area moments of inertia are a measure of the distribution of a two-dimensional area around a particular axis. Fundamentally, the portions of a shape which are located farther from the axis have a greater affect than the parts which are closer. The primary application is in structural engineering and machine design where they are used to determine a structural member's stiffness. Another application is in Fluid Mechanics where they are used to determine the effect of pressure on a submerged surface. We will use the symbol I for this property, along with a subscript to indicate the specific axis, so for example, I_x would indicate the "Area moment of inertia with respect to the x axis."

Warning 10.0.1

The *mass* moment of inertia you learned about in Physics is not the same as the *area* moment of inertia in Statics!

This can be confusing since both are commonly shortened to "moment of inertia" and both use the same symbol, I . They have different units however, and the intended moment of inertia can easily be determined from context or with a unit analysis.

10.1 Integral Properties of Shapes

Key Questions

- Why does the area moment of inertia integral equation include a distance squared term?
- When performing a single integral, either dx or dy , what is your differential element dA shape?

As you know, two dimensional shapes like rectangles and circles have properties such as area, perimeter, and centroid. These are purely *geometric* properties

since they belong to the shape alone, in contrast to *physical* properties like weight and mass which belong to real physical objects.

In this section we introduce several new geometric properties useful in engineering including the **Area Moment of Inertia**.

The integral properties of shapes, along with the names and symbols commonly used to represent them are given in the table below. You are already familiar with *area* from Geometry and the *first moment of area* from Chapter 7. The remaining properties are the subject of this chapter. They all have a similar form, and can be evaluated using similar integration techniques.

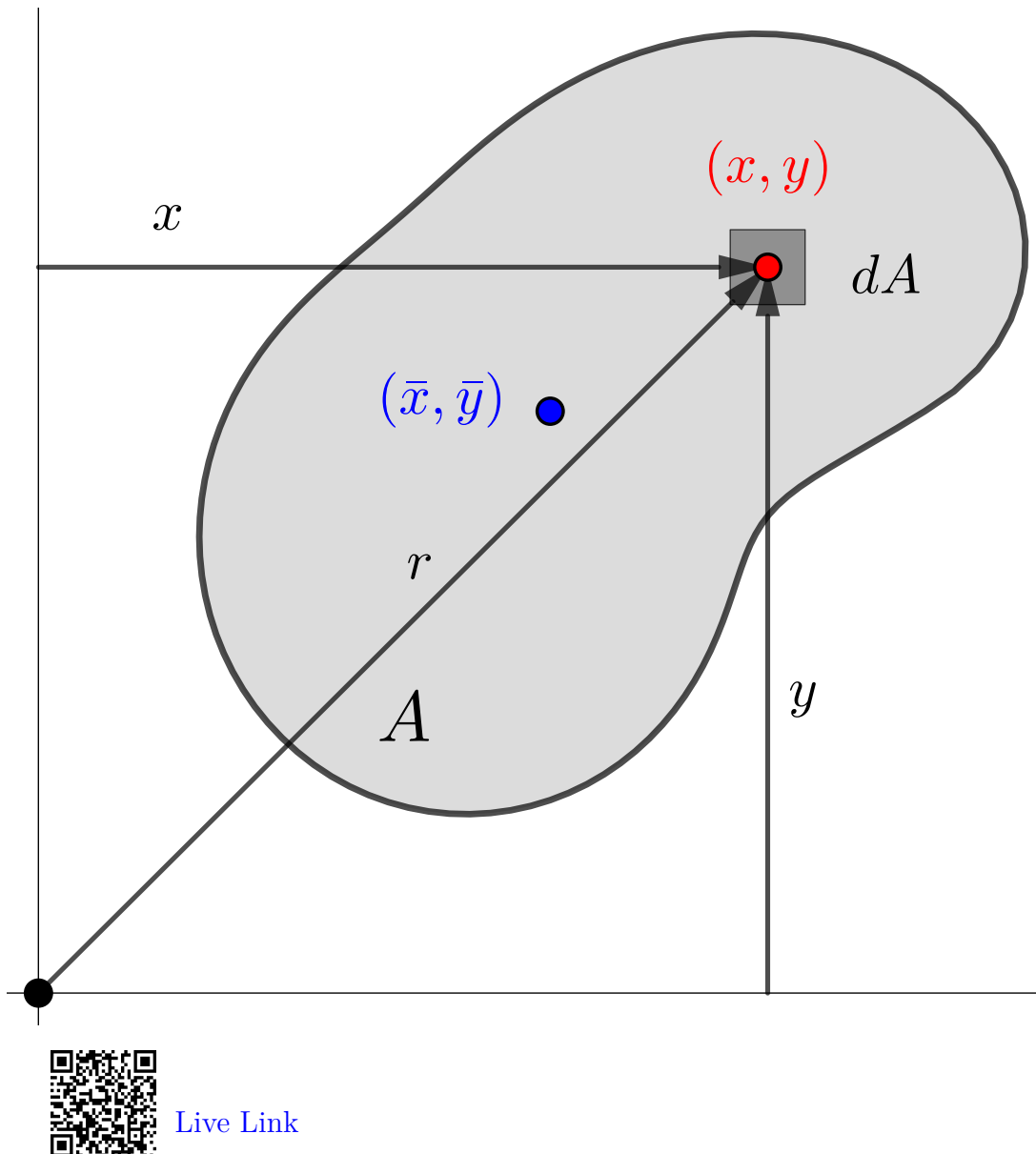

Figure 10.1.1 Definitions for area properties

This interactive diagram defines the terms which apply to all of the property

definitions below. It shows a generic plane area A , divided into differential elements $dA = dx dy$. The differential element dA is an infinitesimally tiny rectangle centered about point (x, y) , which can range over the entire area. The distances to the element from the y axis, the x axis and the origin are designated x , y , and r respectively. The centroid of the entire area is located at (\bar{x}, \bar{y}) .

Definition	Name	More Information
$A = \int_A dA$	Area	Subsection 7.7.2
$Q_x = \int_A y dA$	First Moment of Area (with respect to the x axis)	Chapter 7
$Q_y = \int_A x dA$	First Moment of Area (with respect to the y axis)	Chapter 7
$I_x = \int_A y^2 dA$	Second Moment of Area, or Moment of Inertia (with respect to the x axis)	Section 10.2
$I_y = \int_A x^2 dA$	Second Moment of Area, or Moment of Inertia (with respect to the y axis)	Section 10.2
$J_O = \int_A r^2 dA$	Polar Moment of Inertia	Section 10.5
$I_{xy} = \int_A x y dA$	Product of Inertia	Section 10.7

All of these properties are defined as integrals over an area A . These integrals may be evaluated by double-integrating over x and y in Cartesian coordinates or r and θ in polar coordinates. They can also be evaluated using single integration using the methods demonstrated in [Subsection 10.2.2](#).

None of these integrals can be evaluated until a specific shape is chosen. When shape has been specified, the bounding functions and integration limits can be determined and only then may the integral be solved using appropriate integration techniques. If the shape is specified in general terms, say a rectangle with base b and height h , then the result of the integration will be a formula for the property applicable to all similar shapes.

10.1.1 Area

The total **area** of a shape is found by integrating the differential elements of area over the entire shape.

$$A = \int_A dA. \quad (10.1.1)$$

The limit on this integral is indicated with an A to indicate that the integration is carried out over the entire area. The resulting value will have units of $[\text{length}]^2$ and does not depend on the position of the shape on the coordinate plane.

Since the area formulas for common shapes are well known, you only need to use integration in uncommon situations.

10.1.2 First Moment of Area

The **first moment of area**, which was introduced in [Chapter 7](#), is defined by these two equations.

$$Q_x = \int_A y dA \quad Q_y = \int_A x dA \quad (10.1.2)$$

and has units of $[\text{length}]^3$.

The first moment of area with respect to an axis is a measure of the distribution of the shape about an axis. It depends on the shape and also its location on the coordinate plain. Portions of area on the negative side of the selected axis make the first moment smaller, while areas on the positive side make it larger. If the shape's centroid is located exactly on the axis, the integral will sum to zero because the contributions of area above and below the axis cancel each other.

The average value of the first moment of area is found by is found by dividing the first moment by the area of the shape, and the result indicates the distance from the axis to centroid of the shape.

$$\bar{x} = \frac{\sum \bar{x}_i A_i}{\sum A_i} \quad \bar{y} = \frac{\sum \bar{y}_i A_i}{\sum A_i}.$$

10.1.3 Moment of Inertia

The **area moment of inertia**, the subject of this chapter, is defined by these two equations.

$$I_x = \int_A y^2 dA \qquad I_y = \int_A x^2 dA \qquad (10.1.3)$$

and has units of $[\text{length}]^4$.

As you can see, these equations are similar to the equations for the [first moment of area \(10.1.2\)](#), except that the distance terms x and y are now squared. In recognition of the similarity, the area moments of inertia are also known as the **second moments of area**. We will use the terms moment of inertia and second moment interchangeably. These two quantities are sometimes designated as *rectangular* moments of inertia to distinguish them from the polar moment of inertia described in the next section.

Like the first moment, the second moment of area provides a measure of the distribution of area around an axis, but in this case the distance to each element is squared. This gives increased importance to portions of the area which are far from the axis. Squaring the distance means that identical elements on opposite sides of the axis *both* contribute to the sum rather than cancel each other out as they do in the first moment. As a result, the moment of inertia is always a positive quantity.

Two identical shapes can have completely different moments of inertia, depending on how the shape is distributed around the axis. A shape with most of its area close to the axis has a smaller moment of inertia than the same shape would if its area was distributed farther from the axis. This is a non-linear effect, because when the distance term is doubled, the contribution of that element to the sum increases fourfold.

Question 10.1.2

These three triangles are all the same size. Rank them from smallest to largest moment of inertia with respect to the y axis.

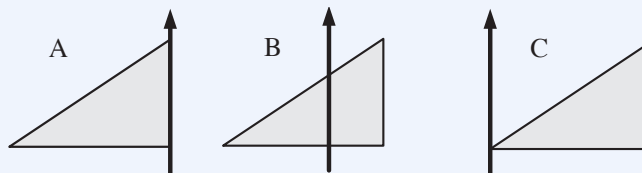

Answer. From smallest to largest: $I_B < I_A < I_C$.

Solution. Although the areas of all three triangles are the same, triangle B has area on both sides of the y axis and relatively close to it, and so has the smallest moment of inertia, while triangle C has the most of its area far from the y axis which makes its moment of inertia largest.

For parallel axes, the minimum moment of inertia will be about an axis

passing through the centroid, and when axis B is centroidal $I_C = 3I_A = 9I_B$.

Moving a shape away from the axis (or moving the axis away from the shape) increases its moment of inertia, and moving it closer to the axis decreases it, until it crosses to the other side of the axis, and then its moment of inertia will begin to increase again.

The minimum moment of inertia occurs when the centroid of the shape falls on the axis. When this occurs, the moment of inertia is called the **centroidal moment of inertia**. A bar over the symbol I is used to indicate that a moment of inertia is centroidal. So for example, \bar{I}_x and \bar{I}_y represent the “centroidal moment of inertia with respect to the x axis” and the “the centroidal moment of inertia with respect to the y axis.” The bar in this case does not mean that moment of inertia is a vector quantity. Note that a shape can have multiple centroidal moments of inertia, because more than one axis can pass through the centroid of a shape. In this text, we will only the vertical and horizontal axes, but they are not the only possibilities.

The centroidal moment of inertia is particularly important. We will see in (10.3.1) that if we know a shape’s centroidal moment of inertia for some axis direction, it is a simple process to calculate the moment of inertia of the shape about any other parallel axis. The moment of inertia is used in Mechanics of Materials to find stress and deflection in beams and to determine the load which will cause a column to buckle.

We stated earlier that the centroidal moment of inertia is the minimum moment of inertia, but by this we mean, the minimum moment of inertia for a particular axis direction, for example horizontal. Other centroidal axes may have a different moment of inertia, either larger or smaller than the moment of inertia about a horizontal centroidal axis. The centroidal axes which have the absolute minimum and maximum moment of inertia are called the principle axes. The principle axes are not necessarily horizontal and vertical.

Thinking Deeper 10.1.3 Beam bending.

To get a feel for how moment of inertia affects engineering design, find a ruler, a yardstick, or something similar: long with a rectangular cross section.

Try to bend the ruler both when it’s flat and also when it’s turned on edge. You will find that bending the ruler around the x axis while it’s flat is easy compared to bending it the other way, around the z axis. Why is it easier to bend the ruler one way than the other? It’s the same object, made of the same material either way.

The answer has to do with the moment of inertia, and how it relates to the bending axis.

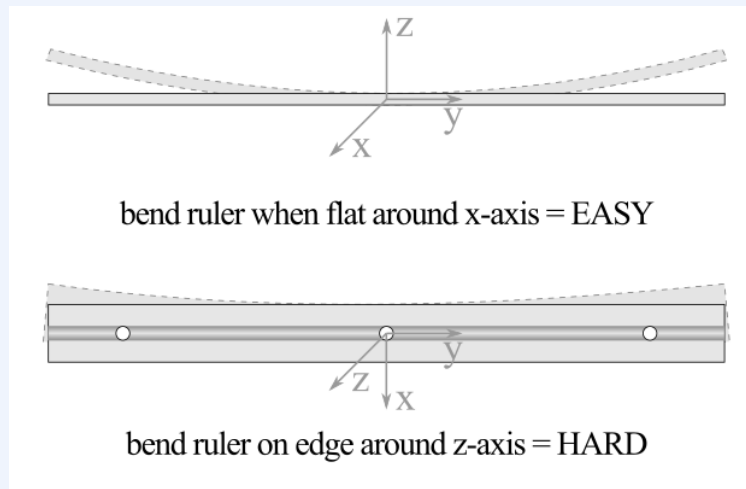

Figure 10.1.4 Bending a ruler.

As engineers we are not satisfied with merely knowing that it's harder to bend a ruler one way than the other, we'd like to know *how much harder*? For a 1/8 in thick ruler that is 1 in tall, the bending resistance about the z axis is over 20 times more than the bending resistance the other way, about the x axis.

To further see how the moment of inertia comes into play, consider the curvature caused by applying opposing moments to the ends of a beam such as your ruler. You will cause it to bend into an arc of a circle of some radius. A curious engineer would like to know how the curvature of the beam is related to the applied moment, the geometry, and the physical properties of the beam.

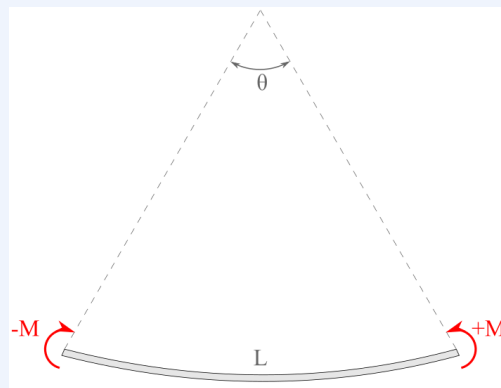

Figure 10.1.5 Beam of length L which is being bent by opposing couple-moments to an arc with angle θ .

You will learn in Mechanics of Materials that the relationship is:

$$M = \theta \left(\frac{EI}{L} \right) \quad (10.1.4)$$

where:

E is a material property called Young's Modulus or the modulus of elasticity which characterizes the stiffness of a material.

L is the length of the beam, and

I is the moment of inertia of the cross-section of the beam about the bending axis.

M is the moment applied to the ends of the beam, and

θ is the curvature of the beam.

Since E and I are in the numerator and L is in the denominator, a longer beam is more flexible and larger values of E or I make the beam stiffer. With those properties fixed, angle θ is directly proportional to the moment M .

The sag, or **deflection**, of a beam when supporting a load is also related to these factors, and the placement of the load as well. For example, if a beam is loaded with a concentrated force P at its center its maximum deflection δ_{\max} will occur at the midpoint, with

$$\delta_{\max} = \frac{PL^3}{48EI}$$

10.1.4 Polar Moment of Inertia

The **polar moment of inertia** is defined as

$$J_O = \int_A r^2 dA \quad (10.1.5)$$

and has units of [length]⁴.

The polar moment of inertia is another measure of the distribution of an area but, in this case, about a point at the origin rather than about an axis. One important application of this value is to quantify the resistance of a shaft to torsion or twisting due to the shape of its cross-section.

Thinking Deeper 10.1.6 Why don't we call the polar moment of inertia I_z ?

The squared distance in the polar moment of inertia formula is the distance from the z axis, so it would seem reasonable to name the polar moment I_z to be consistent with I_x and I_y , which use distances from the x and y axes.

Instead engineers use the letter J to represent this quantity. Why?

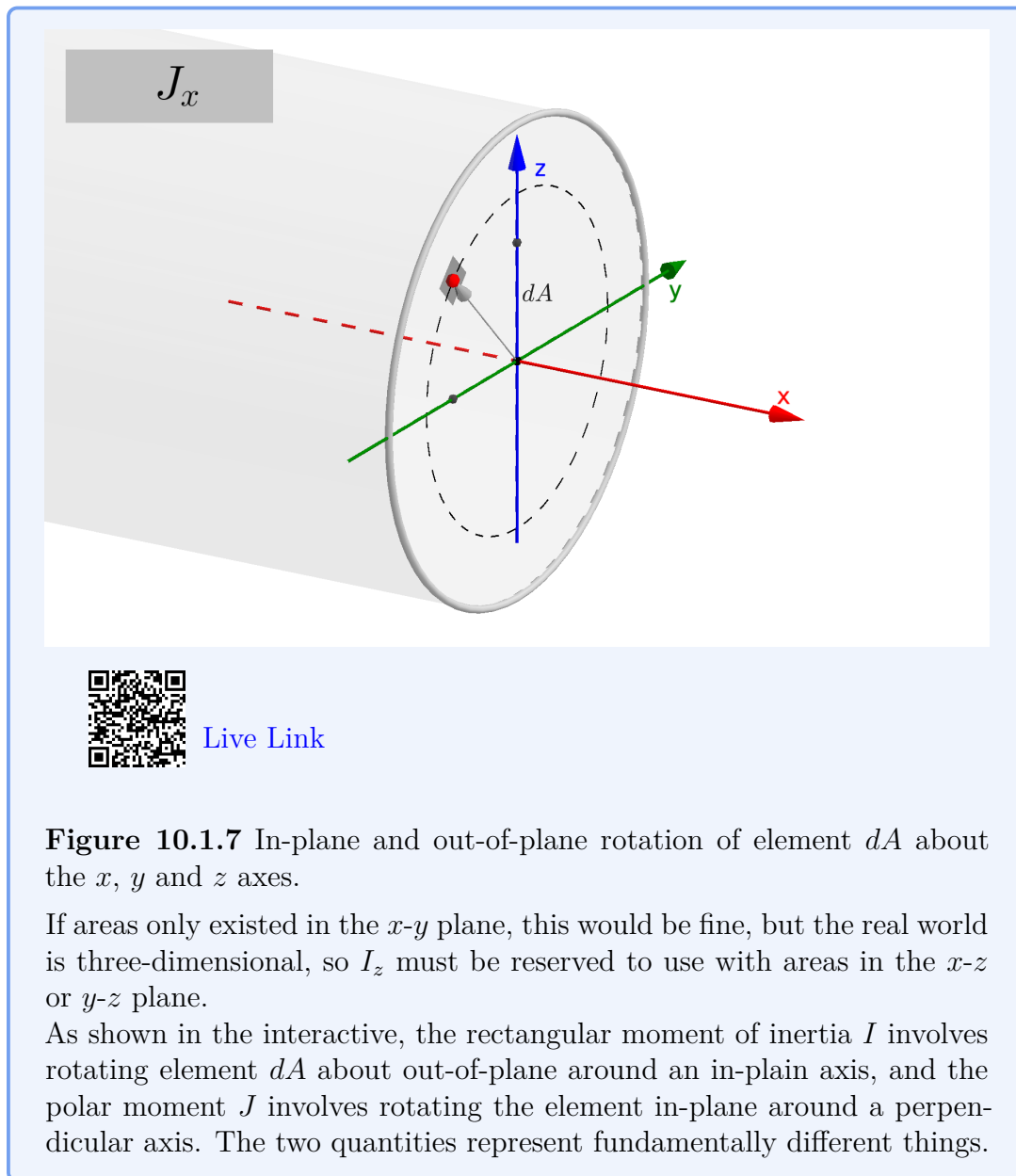

Figure 10.1.7 In-plane and out-of-plane rotation of element dA about the x , y and z axes.

If areas only existed in the x - y plane, this would be fine, but the real world is three-dimensional, so I_z must be reserved to use with areas in the x - z or y - z plane.

As shown in the interactive, the rectangular moment of inertia I involves rotating element dA about out-of-plane around an in-plane axis, and the polar moment J involves rotating the element in-plane around a perpendicular axis. The two quantities represent fundamentally different things.

10.1.5 Product of Inertia

The final property of interest is the **product of inertia** and it is defined as

$$I_{xy} = \int_A xy \, dA \quad (10.1.6)$$

where x and y are defined as in [Figure 10.1.1](#). Like the others, the units associated with this quantity are $[\text{length}]^4$. The name was chosen because the distance squared term in the integral is the *product* of the element's coordinates. In contrast to the other area moments, which are always positive, the product of inertia can be a positive, negative or zero.

10.2 Moments of Inertia of Common Shapes

In following sections we will use the integral definitions of moment of inertia (10.1.3) to find the moments of inertia of five common shapes: rectangle, triangle, circle, semi-circle, and quarter-circle with respect to a specified axis. The integration techniques demonstrated can be used to find the moment of inertia of any two-dimensional shape about any desired axis.

Moments of inertia depend on both the shape, and the axis. Pay attention to the placement of the axis with respect to the shape, because if the axis is located elsewhere or oriented differently, the results will be different.

We will begin with the simplest case: the moment of inertia of a rectangle about a horizontal axis located at its base. This case arises frequently and is especially simple because the boundaries of the shape are all constants.

10.2.1 Moment of Inertia of a Rectangle

Consider the $(b \times h)$ rectangle shown. This rectangle is oriented with its bottom-left corner at the origin and its upper-right corner at the point (b, h) , where b and h are constants.

What is the moment of inertia of this rectangle with respect to the x axis?

To find the moment of inertia, divide the area into square differential elements dA at (x, y) where x and y can range over the entire rectangle and then evaluate the integral using double integration.

The differential element dA has width dx and height dy , so

$$dA = dx \, dy = dy \, dx. \quad (10.2.1)$$

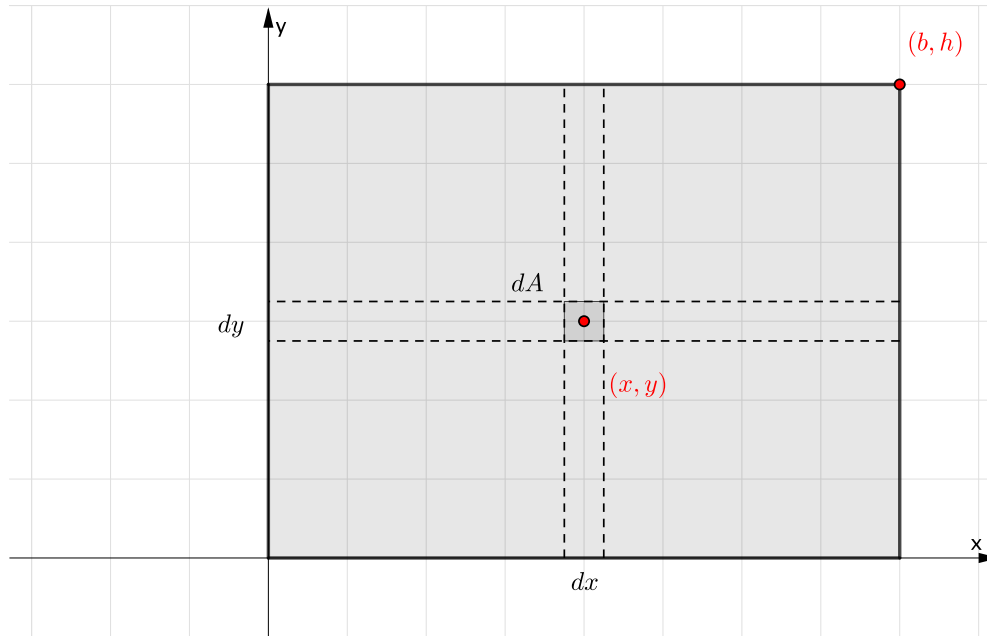

[Live Link](#)

Figure 10.2.1 Rectangle divided into vertical and horizontal differential strips

It would seem like this is an insignificant difference, but the order of dx and dy in this expression determines the order of integration of the double integral. We will try both ways and see that the result is identical.

Using $dA = dx \, dy$

First, we will evaluate (10.1.3) using $dA = dx \, dy$.

If you are not familiar with double integration, briefly you can think of a double integral as two normal single integrals, one ‘inside’ and the other ‘outside,’ which are evaluated one at a time from the inside out. Our integral becomes

$$\begin{aligned}
 I_x &= \int_A y^2 dA \\
 &= \iint y^2 \underbrace{dx \, dy}_{dA} \\
 &= \int_{\text{bottom}}^{\text{top}} \underbrace{\left[\int_{\text{left}}^{\text{right}} y^2 dx \right]}_{\text{inside}} dy \\
 &\quad \underbrace{\hspace{10em}}_{\text{outside}}
 \end{aligned}$$

The limits on double integrals are usually *functions* of x or y , but for this rectangle the limits are all *constants*. The bottom and top limits are $y = 0$ and $y = h$; the left and right limits are $x = 0$ and $x = b$. Note that the y^2 term can be taken out of the inside integral, because in terms of x , it is constant.

Inserting $dx dy$ for dA and the limits into (10.1.3), and integrating starting with the inside integral gives

$$\begin{aligned} I_x &= \int_A y^2 dA \\ &= \int_0^h \int_0^b y^2 dx dy \\ &= \int_0^h y^2 \int_0^b dx dy \\ &= \int_0^h y^2 \boxed{b dy} \\ &= b \int_0^h y^2 dy \\ &= b \left. \frac{y^3}{3} \right|_0^h \end{aligned}$$

Evaluating the limit gives the result

$$I_x = \frac{bh^3}{3}. \quad (10.2.2)$$

This is the formula for the moment of inertia of a rectangle about an axis passing through its base, and is worth remembering.

The boxed quantity is the *result* of the inside integral times dx , and can be interpreted as the *differential area* of a horizontal strip,

$$dA = b dy.$$

This will allow us to set up a problem as a single integral using strips and skip the inside integral completely as we will see in [Subsection 10.2.2](#).

This result means that the moment of inertia of the rectangle depends only on the dimensions of the base and height and has units $[\text{length}]^4$. The height term is cubed and the base is not, which is unsurprising because the moment of inertia gives more importance to parts of the shape which are farther away from the axis. Doubling the width of the rectangle will double I_x but doubling the height will increase I_x eightfold. In all moment of inertia formulas, the dimension perpendicular to the axis is always cubed.

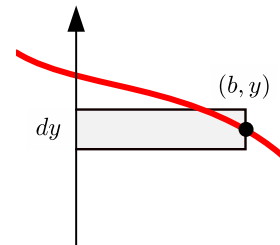

Warning 10.2.2

This result is for this particular situation; you will get a different result for a different shape or a different axis.

Using $dA = dy \, dx$

Now, we will evaluate (10.1.3) using $dA = dy \, dx$ which reverses the order of integration and means that the integral over y gets conducted first. Since the distance-squared term y^2 is a function of y it remains inside the inside integral this time and the result of the inside integral is not an area as it was previously.

Inserting $dy \, dx$ for dA and the limits into (10.1.3), and integrating gives

$$\begin{aligned} I_x &= \int_A y^2 \, dA \\ &= \int_0^b \int_0^h y^2 \, dy \, dx \\ &= \int_0^b \left. \frac{y^3}{3} \, dy \right|_0^h \, dx \\ &= \int_0^b \boxed{\frac{h^3}{3} \, dx} \\ &= \frac{h^3}{3} \int_0^b dx \\ I_x &= \frac{bh^3}{3} \end{aligned}$$

As before, the result is the moment of inertia of a rectangle with base b and height h , about an axis passing through its base. We have found that the moment of inertia of a rectangle about an axis through its base is (10.2.2), the same as before.

The boxed quantity is the *result* of the inside integral times dx , and can be interpreted as the *differential moment of inertia* of a vertical strip about the x axis. This is consistent our previous result. The vertical strip has a base of dx and a height of h , so its moment of inertia by (10.2.2) is

$$dI_x = \frac{h^3}{3} dx. \quad (10.2.3)$$

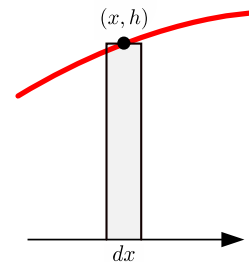

We will use these results to set up problems as a single integral which sum the moments of inertia of the differential strips which cover the area in [Subsection 10.2.3](#).

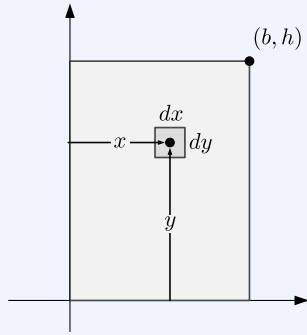
Example 10.2.3 I_y of a Rectangle.

Find the moment of inertia of the rectangle about the y axis using square differential elements dA .

Solution 1. Following the same procedure as before, we divide the rectangle into square differential elements $dA = dx \, dy$ and evaluate the double integral for I_y from (10.1.3) first by integrating over x , and then over y .

$$\begin{aligned}
 I_y &= \int_A x^2 dA \\
 &= \int_0^h \int_0^b x^2 \, dx \, dy \\
 &= \int_0^h \left[\int_0^b x^2 \, dx \right] dy \\
 &= \int_0^h \left[\frac{x^3}{3} \right]_0^b dy \\
 &= \int_0^h \frac{b^3}{3} dy \\
 &= \frac{b^3}{3} y \Big|_0^h \\
 I_y &= \frac{b^3 h}{3}
 \end{aligned}$$

The formula for I_y is the same as the formula as we found previously for I_x except that the base and height terms have reversed roles. Here, the horizontal dimension is cubed and the vertical dimension is the linear term. In all moment of inertia formulas, the dimension perpendicular to the axis is cubed.

Solution 2. This solution demonstrates that the result is the same when the order of integration is reversed. This time we evaluate I_y by dividing the rectangle into square differential elements $dA = dy \, dx$ so the inside integral is now with respect to y and the outside integral is with respect

to x .

$$\begin{aligned}
 I_y &= \int_A x^2 dA \\
 &= \int_0^b x^2 \left[\int_0^h dy \right] dx \\
 &= \int_0^b x^2 \boxed{h dx} \\
 &= h \int_0^b x^2 dx \\
 &= h \left. \frac{x^3}{3} \right|_0^b \\
 I_y &= \frac{hb^3}{3}
 \end{aligned}$$

Centroidal Moment of Inertia

As discussed in [Subsection 10.1.3](#), a moment of inertia about an axis passing through the area's centroid is a *Centroidal* Moment of Inertia. The convention is to place a bar over the symbol I when the axis is centroidal.

The following example finds the centroidal moment of inertia for a rectangle using integration.

Example 10.2.4 Rectangle.

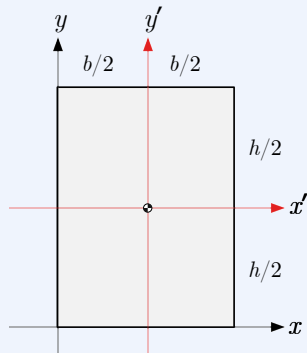

Use integration to find the moment of inertia of a $(b \times h)$ rectangle about the x' and y' axes passing through its centroid.

Indicate that the result is a *centroidal* moment of inertia by putting a bar over the symbol I .

Solution. We can use the same approach with $dA = dy dx$, but now the limits of integration over y are now from $-h/2$ to $h/2$.

$$\begin{aligned}
 \bar{I}_{x'} &= \int_A y^2 dA \\
 &= \int_0^b \int_{-h/2}^{h/2} y^2 dy dx
 \end{aligned}$$

$$\begin{aligned}
 &= \int_0^b \left[\frac{y^3}{3} dy \right]_{-h/2}^{h/2} dx \\
 &= \frac{h^3}{12} \int_0^b dx \\
 \bar{I}_{x'} &= \frac{bh^3}{12}
 \end{aligned}$$

Notice that the centroidal moment of inertia of the rectangle is smaller than the corresponding moment of inertia about the baseline.

The solution for $\bar{I}_{y'}$ is similar.

Thinking Deeper 10.2.5 Stresses in a Rectangular Beam.

To provide some context for area moments of inertia, let's examine the internal forces in a elastic beam. Assume that some external load is causing an external bending moment which is opposed by the internal forces exposed at a cut.

When an elastic beam is loaded from above, it will sag. Fibers on the top surface will compress and fibers on the bottom surface will stretch, while somewhere in between the fibers will neither stretch or compress. The points where the fibers are not deformed defines a transverse axis, called the **neutral axis**. The neutral axis passes through the centroid of the beam's cross section.

The change in length of the fibers are caused by internal compression and tension forces which increase linearly with distance from the neutral axis. The internal forces sum to zero in the horizontal direction, but they produce a net couple-moment which resists the external bending moment.

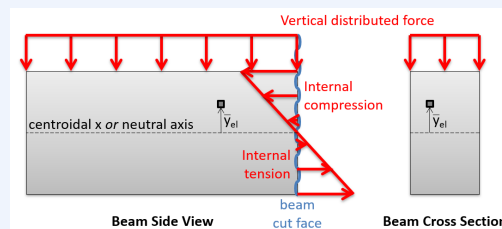

Figure 10.2.6 Internal forces in a beam caused by an external load.

Think about summing the internal moments about the neutral axis on the beam cut face. This moment at a point on the face increases with the square of the distance y of the point from the neutral axis because both the internal force and the moment arm are proportional to this distance. The appearance of y^2 in this relationship is what connects a bending beam to the area moment of inertia.

The shape of the beam's cross-section determines how easily the beam

bends. A beam with more material farther from the neutral axis will have a larger moment of inertia and be stiffer. Of course, the material of which the beam is made is also a factor, but it is independent of this geometrical factor.

10.2.2 Moment of Inertia of a Triangle

We saw in the last section that when solving (10.1.3) the double integration could be conducted in either order, and that the result of completing the inside integral was a single integral. We will use these observations to optimize the process of finding moments of inertia for other shapes by avoiding double integration.

The most straightforward approach is to use the definitions of the moment of inertia (10.1.3) along with strips *parallel* to the designated axis, i.e. horizontal strips when you want to find the moment of inertia about the x axis and vertical strips for the moment of inertia about the y axis.

The strip must be parallel in order for (10.1.3) to work; when parallel, all parts of the strip are the same distance from the axis.

This approach only works if the bounding function can be described as a function of y and as a function of x , to enable integration with respect to x for the vertical strip, and with respect to y for the horizontal strip.

Example 10.2.7 Triangle.

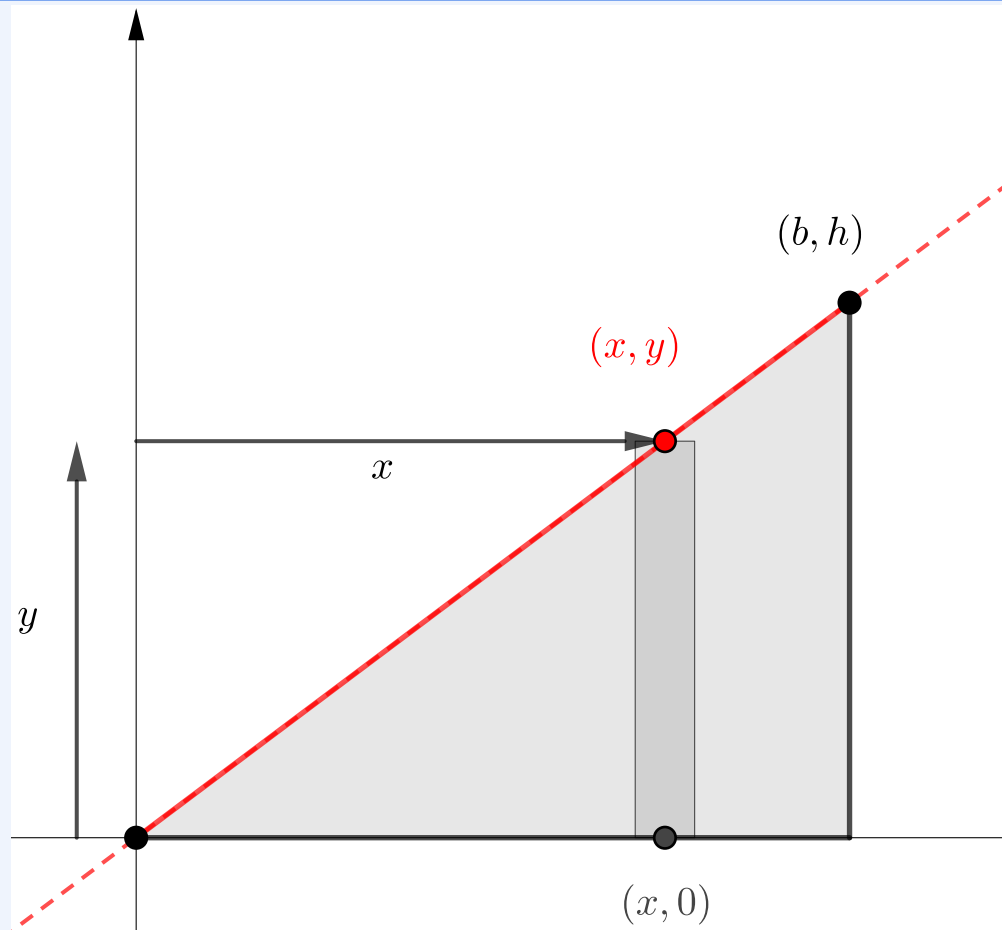

[Live Link](#)

Find the moment of inertia of the $(b \times h)$ right triangle with respect to the x and y axes?

Solution. As we did when finding centroids in [Section 7.7](#) we need to evaluate the bounding function of the triangle. The bottom are constant values, $y = 0$ and $x = b$, but the top boundary is a straight line passing through the origin and the point at (b, h) , which has the equation

$$y(x) = \frac{h}{b}x. \quad (10.2.4)$$

By inspection we see that the a vertical strip extends from the x axis to the function so $dA = y dx$.

Since vertical strips are parallel to the y axis we can find I_y by evaluating

this integral with $dA = y \, dx$, and substituting $\frac{h}{b}x$ for y

$$\begin{aligned}
 I_y &= \int_A x^2 \, dA \\
 &= \int_0^b x^2 y \, dx \\
 &= \int_0^b x^2 \left(\frac{h}{b}x \right) dx \\
 &= \frac{h}{b} \int_0^b x^3 dx \\
 &= \frac{h}{b} \frac{x^4}{4} \Big|_0^b \\
 I_y &= \frac{hb^3}{4}
 \end{aligned}$$

Similarly we will find I_x using horizontal strips, by evaluating this integral with $dA = (b - x)dy$

$$I_x = \int_A y^2 dA$$

We are expressing dA in terms of dy , so everything inside the integral must be constant or expressed in terms of y in order to integrate. In particular, we will need to solve (10.2.4) for x as a function of y . This is not difficult.

$$x(y) = \frac{b}{h}y.$$

Once this has been done, evaluating the integral is straightforward.

$$\begin{aligned}
 I_x &= \int_A y^2 \, dA \\
 &= \int_0^h y^2 (b - x) \, dy \\
 &= \int_0^h y^2 \left(b - \frac{b}{h}y \right) dy \\
 &= b \int_0^h y^2 dy - \frac{b}{h} \int_0^h y^3 dy \\
 &= \frac{bh^3}{3} - \frac{b}{h} \frac{h^4}{4} \\
 I_x &= \frac{bh^3}{12}
 \end{aligned}$$

This is the moment of inertia of a right triangle about an axis passing through its base. By reversing the roles of b and h , we also now have the moment of inertia of a right triangle about an axis passing through its vertical side.

$$I_y = \frac{hb^3}{12}.$$

10.2.3 Moment of Inertia of a Differential Strip

We saw in [Subsection 10.2.2](#) that a straightforward way to find the moment of inertia using a single integration is to use strips which are parallel to the axis of interest, so use vertical strips to find I_y and horizontal strips to find I_x .

This method requires expressing the bounding function both as a function of x and as a function of y : $y = f(x)$ and $x = g(y)$. There are many functions where converting from one form to the other is not easy.

As an example, let's try finding I_x and I_y for the spandrel bounded by

$$y = f(x) = x^3 + x, \text{ the } x \text{ axis, and } x = 1.$$

Finding I_y using vertical strips is relatively easy. Letting $dA = y \, dx$ and substituting $y = f(x) = x^3 + x$ we have

$$\begin{aligned} I_y &= \int_A x^2 \, dA \\ &= \int_0^1 x^2 y \, dx \\ &= \int_0^1 x^2 (x^3 + x) \, dx \\ &= \int_0^1 (x^5 + x^3) \, dx \\ &= \left. \frac{x^6}{6} + \frac{x^4}{4} \right|_0^1 \\ I_y &= \frac{5}{12} \end{aligned}$$

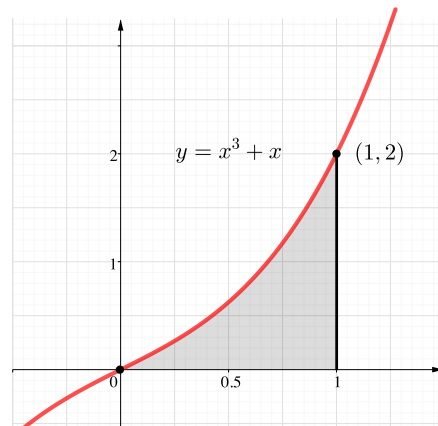

Finding I_x using horizontal strips is anything but easy. In fact, the integral that needs to be solved is this monstrosity

$$\begin{aligned} I_x &= \int_A y^2 (1 - x) \, dy \\ &= \int_0^2 y^2 \left(1 - \frac{\sqrt[3]{2} \left(\sqrt{81y^2 + 12} + 9y \right)^{2/3} - 2\sqrt[3]{3}}{6^{2/3} \sqrt[3]{\sqrt{81y^2 + 12} + 9y}} \right) dy \end{aligned}$$

... and then a miracle occurs

$$I_x = \frac{49}{120}$$

Clearly, a better approach would be helpful.

When using strips which are *parallel* to the axis of interest is impractical mathematically, the alternative is to use strips which are *perpendicular* to the axis.

Applying our previous result (10.2.2) to a vertical strip with height h and infinitesimal width dx gives the strip's differential moment of inertia. In most cases, h will be a function of x .

$$I_x = \frac{bh^3}{3} \quad \rightarrow \quad dI_x = \frac{h^3}{3} dx \quad (10.2.5)$$

. This is the same result that we saw previously (10.2.3) after integrating the inside integral for the moment of inertia of a rectangle.

This result makes it much easier to find I_x for the spandrel that was nearly impossible to find with horizontal strips.

$$\begin{aligned} I_x &= \int_A dI_x = \int_0^1 \frac{y^3}{3} dx \\ &= \int_0^1 \frac{(x^3 + x)^3}{3} dx \\ &= \frac{1}{3} \int_0^1 (x^9 + 3x^7 + 3x^5 + x^3) dx \\ &= \frac{1}{3} \left[\frac{x^{10}}{10} + \frac{3x^8}{8} + \frac{3x^6}{6} + \frac{x^4}{4} \right]_0^1 \\ &= \frac{1}{3} \left[\frac{1}{10} + \frac{3}{8} + \frac{3}{6} + \frac{1}{4} \right] \\ &= \frac{1}{3} \left[\frac{12 + 45 + 60 + 30}{120} \right] \\ I_x &= \frac{49}{120} \end{aligned}$$

The same approach can be used with a horizontal strip dy high and b wide, in which case we have

$$I_y = \frac{b^3 h}{3} \quad \rightarrow \quad dI_y = \frac{b^3}{3} dy \quad (10.2.6)$$

. The width b will usually have to be expressed as a function of y .

The expression for dI_x assumes that the vertical strip has a lower bound on the x axis. If this is not the case, then find the dI_x for the area between the bounds by subtracting dI_x for the rectangular element below the lower bound from dI_x for the element from the x axis to the upper bound. A similar procedure can be used for horizontal strips.

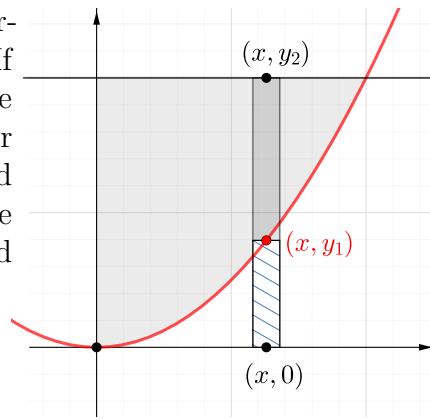

$$dI_x = \frac{y_2^3}{3} - \frac{y_1^3}{3} = \frac{1}{3}(y_2^3 - y_1^3)$$

This approach is illustrated in the next example.

Example 10.2.8 Moment of Inertia for Area Between Two Curves.

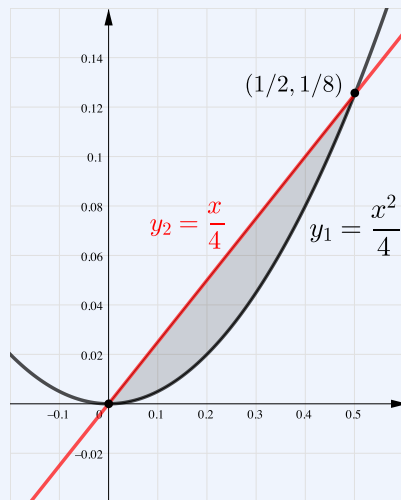

Use vertical strips to find both I_x and I_y for the area bounded by the functions

$$y_1 = x^2/4 \text{ and,} \\ y_2 = x/4$$

Units are cm.

Solution.

1. Set up the integral.

The area is bounded by the functions

$$y_2 = x/4 \qquad y_2 = x^2/2$$

By equating the two functions, we learn that they intersect at $(0, 0)$ and $(1/2, 1/8)$, so the limits on x are $x = 0$ and $x = 1/2$.

The differential area dA for vertical strip is

$$dA = (y_2 - y_1) dx = \left(\frac{x}{4} - \frac{x^2}{2} \right) dx.$$

2. Find I_y .

For vertical strips, which are parallel to the y axis we can use the definition of the Moment of Inertia.

$$\begin{aligned}
 I_y &= \int x^2 dA \\
 &= \int_0^{0.5} x^2 \left(\frac{x}{4} - \frac{x^2}{2} \right) dx \\
 &= \int_0^{1/2} \left(\frac{x^3}{4} - \frac{x^4}{2} \right) dx \\
 &= \left(\frac{x^4}{16} - \frac{x^5}{10} \right) \Big|_0^{1/2} \\
 &= \left(\frac{(1/2)^4}{16} - \frac{(1/2)^5}{10} \right) \\
 &= \frac{1}{64} \left(\frac{1}{4} - \frac{1}{5} \right) \\
 I_y &= \frac{1}{1280} = 7.81 \times 10^{-4} \text{ cm}^4
 \end{aligned}$$

3. Find I_x .

For vertical strips, which are perpendicular to the x axis, we will take subtract the moment of inertia of the area below y_1 from the moment of inertia of the area below y_2 .

$$\begin{aligned}
 I_x &= \int_{A_2} dI_x - \int_{A_1} dI_x \\
 &= \int_0^{1/2} \frac{y_2^3}{3} dx - \int_0^{1/2} \frac{y_1^3}{3} dx \\
 &= \frac{1}{3} \int_0^{1/2} \left[\left(\frac{x}{4} \right)^3 - \left(\frac{x^2}{2} \right)^3 \right] dx \\
 &= \frac{1}{3} \int_0^{1/2} \left[\frac{x^3}{64} - \frac{x^6}{8} \right] dx \\
 &= \frac{1}{3} \left[\frac{x^4}{256} - \frac{x^7}{56} \right]_0^{1/2} \\
 I_x &= \frac{1}{28672} = 3.49 \times 10^{-6} \text{ cm}^4
 \end{aligned}$$

10.2.4 Circles, Semicircles, and Quarter-circles

In this section, we will use polar coordinates and symmetry to find the moments of inertia of circles, semi-circles and quarter-circles.

We will start by finding the polar moment of inertia of a circle with radius r , centered at the origin. You will recall from [Subsection 10.1.4](#) that the polar moment of inertia is similar to the ordinary moment of inertia, except the distance squared term is the distance from the element to a point in the plane rather than the perpendicular distance to an axis, and it uses the symbol J with a subscript indicating the point.

To take advantage of the geometry of a circle, we'll divide the area into thin rings, as shown in the diagram, and define the distance from the origin to a point on the ring as ρ . The reason for using thin rings for dA is the same reason we used strips parallel to the axis of interest to find I_x and I_y ; all points on the differential ring are the same distance from the origin, so we can find the moment of inertia using single integration.

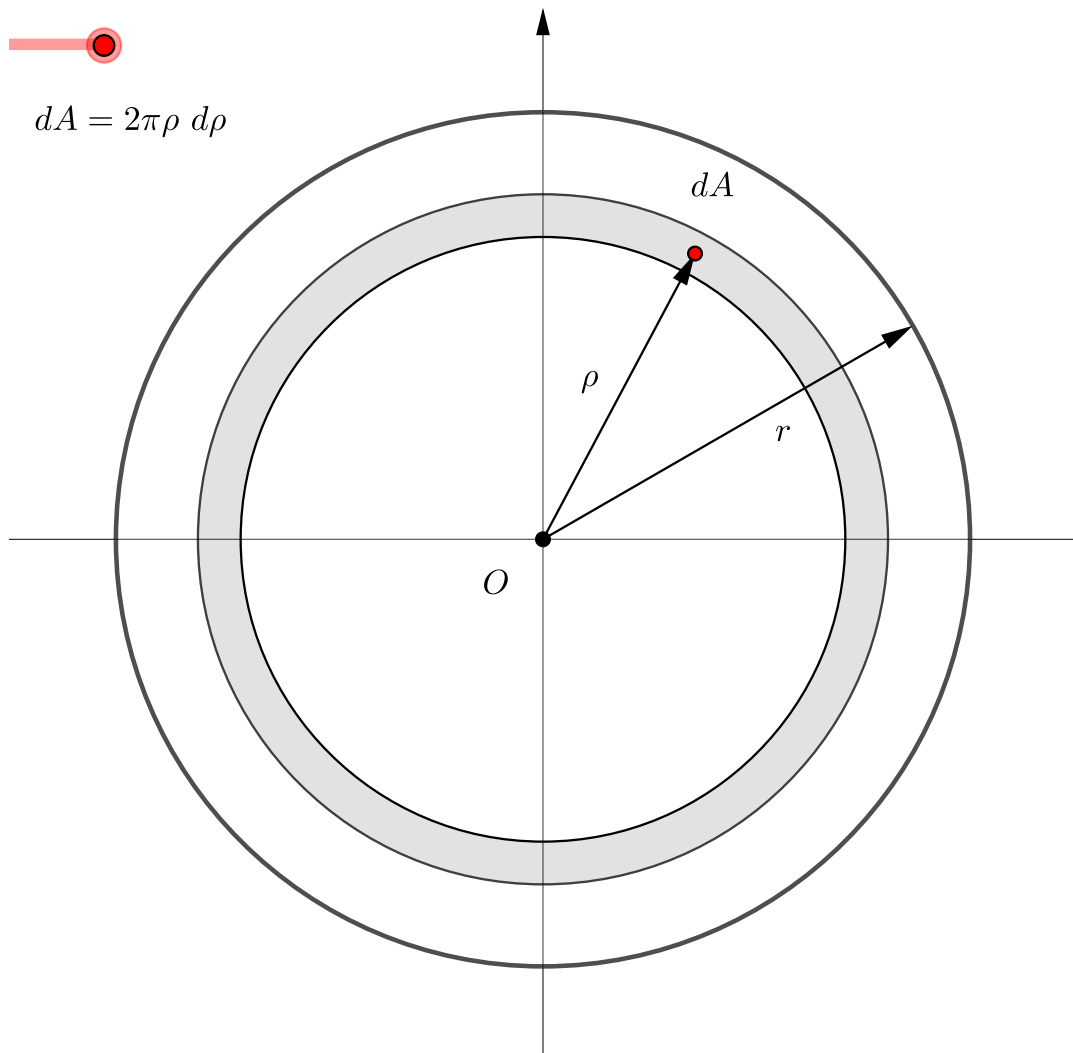

[Live Link](#)

Figure 10.2.9 Circle divided into differential rings

The differential area of a circular ring is the circumference of a circle of radius ρ times the thickness $d\rho$.

$$dA = 2\pi\rho d\rho.$$

Adapting the basic formula for the polar moment of inertia (10.1.5) to our labels, and noting that limits of integration are from $\rho = 0$ to $\rho = r$, we get

$$J_O = \int_A r^2 dA \quad \rightarrow \quad J_O = \int_0^r \rho^2 2\pi\rho d\rho \quad (10.2.7)$$

Proceeding with the integration,

$$\begin{aligned}
 J_O &= \int_0^r \rho^2 2\pi\rho \, d\rho \\
 &= 2\pi \int_0^r \rho^3 \, d\rho \\
 &= 2\pi \left[\frac{\rho^4}{4} \right]_0^r \\
 J_O &= \frac{\pi r^4}{2}
 \end{aligned} \tag{10.2.8}$$

This is the polar moment of inertia of a circle about a point at its center.

With this result, we can find the rectangular moments of inertia of circles, semi-circles and quarter circle simply. Noting that the polar moment of inertia of a shape is the sum of its rectangular moments of inertia I_x and I_y , these are equal to each other for a circle due to its symmetry. Therefore, by (10.5.2), which is easily proven,

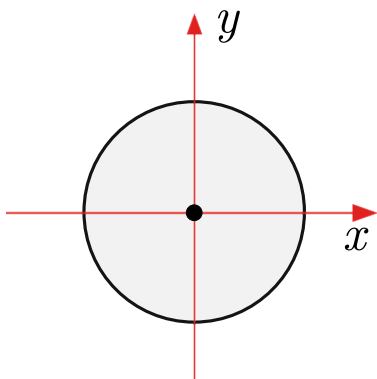

$$\begin{aligned}
 J_O &= I_x + I_y \\
 \bar{I}_x &= \bar{I}_y = \frac{J_O}{2} = \frac{\pi r^4}{4}
 \end{aligned} \tag{10.2.9}$$

This is the moment of inertia of a circle about a vertical or horizontal axis passing through its center.

A circle consists of two semi-circles above and below the x axis, so the moment of inertia of a semi-circle about a diameter on the x axis is just half of the moment of inertia of a whole circle. The moment of inertia about the vertical centerline is the same.

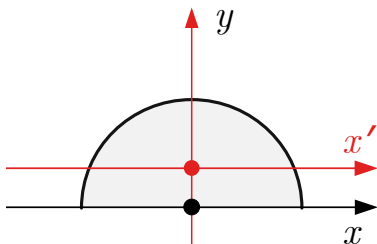

$$I_x = \bar{I}_y = \frac{\pi r^4}{8}. \tag{10.2.10}$$

Similarly, the moment of inertia of a quarter circle is half the moment of inertia of a semi-circle, so

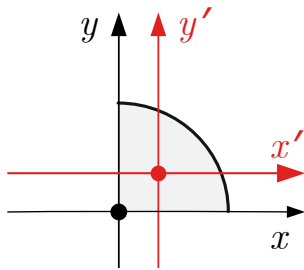

$$I_x = I_y = \frac{\pi r^4}{16}. \quad (10.2.11)$$

In these diagrams, the centroidal axes are red, and moments of inertia about centroidal axes are indicated by the overbar. We will see how to use the parallel axis theorem to find the centroidal moments of inertia for semi- and quarter-circles in [Section 10.3](#).

10.2.5 Summary of Integration Techniques

Here is a summary of the alternate approaches to finding the moment of inertia of a shape using integration.

You may choose to divide the shape into square differential elements to compute the moment of inertia using the fundamental definitions. The disadvantage of this approach is that you need to set up and compute a double integral. Identifying the correct limits on the integrals is often difficult.

If you would like to avoid double integration, you may use vertical or horizontal strips, but you must take care to apply the correct integral. If you use vertical strips to find I_y or horizontal strips to find I_x , then you can still use [\(10.1.3\)](#), but skip the double integration. When the entire strip is the same distance from the designated axis, integrating with a parallel strip is equivalent to performing the inside integration of [\(10.1.3\)](#).

As we have seen, it can be difficult to solve the bounding functions properly in terms of x or y to use parallel strips. In this case, you can use vertical strips to find I_x or horizontal strips to find I_y by integrating the differential moment of inertia of the strip as discussed in [Subsection 10.2.3](#).

Table 10.2.10 Moment of Inertia Integration Strategies

Element	dA	dI
	$dA = dx dy$ or $dA = dy dx$	$dI_x = y^2 dA$ $dI_y = x^2 dA$
	$dA = (a - x) dy$	$dI_x = y^2 dA$ $dI_y = \frac{(a^3 - x^3)}{3} dx$
	$dA = y dx$	$dI_x = \frac{y^3}{3} dx$ $dI_y = x^2 dA$

10.3 Parallel Axis Theorem

The parallel axis theorem relates the moment of inertia of a shape about an arbitrary axis to its moment of inertia about a parallel centroidal axis.

This theorem is particularly useful because if we know the centroidal moment of inertia of a shape, we can calculate its moment of inertia about any parallel axis by adding an appropriate correction factor. Alternately, if we know the moment of inertia about an axis, we can find the associated centroidal moment of inertia by subtracting the same factor.

The centroidal moment of inertia of common shapes are well known, and readily available in tables of properties of shapes such as [Subsection 10.3.2](#).

10.3.1 Derivation

We will use the defining equation for the moment of inertia (10.1.3) to derive the parallel axis theorem.

The diagram shows an arbitrary shape, and two parallel axes: the x' axis, drawn in red, passes through the centroid of the shape at C , and the x axis, which is parallel and separated by a distance, d . The shape has area A , which is divided into square differential elements dA . The distance from the x axis to the element dA is y , and the distance from the x' axis is y' .

By (10.1.3), the moment of inertia of the shape about the x and x' axes are

$$I_x = \int_A y^2 dA \quad \bar{I}_{x'} = \int_A (y')^2 dA$$

The first is the value we are looking for, and the second is the centroidal moment of inertia of the shape. These two are related through the distance d , because $y = d + y'$. Substituting that relation into the first equation and expanding the binomial gives

$$\begin{aligned} I_x &= \int_A (d + y')^2 dA \\ &= \int_A [(y')^2 + 2 y' d + d^2] dA \\ &= \int_A (y')^2 dA + 2d \int_A y' dA + d^2 \int_A dA \end{aligned}$$

You should recognize these three integrals. The first is the centroidal moment of inertia of the shape $\bar{I}_{x'}$, and the third is the total area of the shape, A . The middle integral is $Q_{x'}$, the [first moment of area](#) (10.1.2) with respect to the centroidal axis x' . So we have,

$$I_x = \bar{I}_{x'} + 2dQ_{x'} + d^2A.$$

Furthermore, $Q_{x'}$ is exactly zero because the x' axis passes through the centroid, meaning that elements of area above and below the centroidal axis exactly balance and cancel each other out. After dropping the middle term we get the version of the parallel axis theorem which you should remember,

$$I = \bar{I} + Ad^2. \quad (10.3.1)$$

The subscripts designating the x and x' axes have been dropped because this equation is applicable to any direction of parallel axes, not specifically horizontal axes.

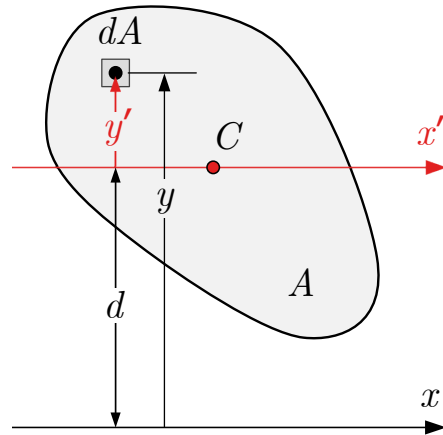
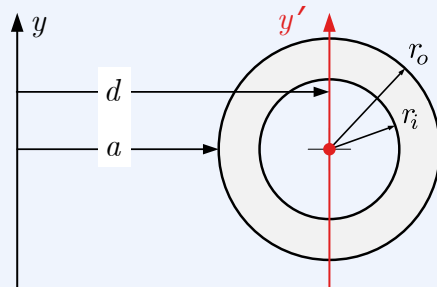

Figure 10.3.1 Definitions for the parallel axis theorem.

This equation says that you find the moment of inertia of a shape about *any* axis by adding Ad^2 to the *parallel* centroidal moment of inertia. You can consider the Ad^2 term as ‘correction factor’ to account for the distance of the axis from the centroid. This term is always positive, so the centroidal moment of inertia is always the minimum moment of inertia for a particular axis direction.

The next example show how the parallel axis theorem is typically used to find the moment of inertia of a shape about an axis, by using then centroidal moment of inertia formulas found in [Subsection 10.3.2](#).

Example 10.3.2 Circular Ring.



Use the parallel axis theorem to find the moment of inertia of the circular ring about the y axis.

The dimensions of the ring are $R_i = 30$ mm, $R_o = 45$ mm, and $a = 80$ mm.

Solution. To apply the parallel axis theorem, we need three pieces of information

1. The centroidal moment of inertia of the ring, I_y ,
2. the area of the ring, A ,
3. the distance between the two parallel axes, d .

The area of the ring is found by subtracting the area of the inner circle from the area of the outer circle. The centroidal moment of inertia is calculated similarly using (10.2.9). The distance between the y and y' axis is available from the diagram. Inserting these values into the parallel axis theorem gives,

$$\begin{aligned}
 I_y &= I_y + Ad^2 \\
 &= \underbrace{\frac{\pi}{4}(r_o^4 - r_i^4)}_{I_y} + \underbrace{\pi(r_o^2 - r_i^2)}_A \underbrace{(a + r_o)^2}_{d^2} \\
 &= \frac{\pi}{4}(45^4 - 30^4) + \pi(45^2 - 30^2)(80 + 45)^2 \\
 &= 2.58 \times 10^6 \text{ mm}^4 + 55.2 \times 10^6 \text{ mm}^4 \\
 I_y &= 57.8 \times 10^6 \text{ mm}^4
 \end{aligned}$$

It is interesting that the ‘correction factor’ is more than 20 times greater than the centroidal moment of inertia of the ring. This indicates the

importance of the distance squared term on the moment of inertia of a shape.

You may feel like the answer to this problem is “too big”. Large answers are normal in problems like this because the moment of inertia involves raising lengths the fourth power.

If it really bothers you, you can convert the results from mm^4 to m^4 , but then the number will probably feel “too small” to you. It’s best not to worry about it.

The parallel axis theorem can also be used to find a centroidal moment of inertia when you already know the moment of inertia of a shape about another axis, by using the theorem ‘backwards’,

$$I = \bar{I} + Ad^2 \quad \rightarrow \quad \bar{I} = I - Ad^2$$

Example 10.3.3 Centroidal Moment of Inertia of a Triangle.

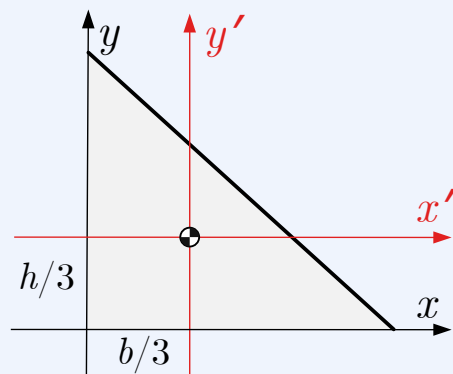

Find the centroidal moment of inertia of a triangle knowing that the moment of inertia about its base is

$$I_x = \frac{1}{12}bh^3.$$

Solution. For the triangle we have the following information: $I_x = bh^3/12$, $A = bh/2$, and $d = \bar{y} = h/3$.

Looking for $\bar{I}_{x'}$:

$$\begin{aligned} I &= \bar{I} + Ad^2 && \text{Parallel Axis Theorem, general statement} \\ \bar{I}_{x'} &= I_x - A(\bar{y})^2 && \text{Parallel Axis Theorem, backwards} \\ &= \frac{bh^3}{12} - \frac{bh}{2} \left(\frac{h}{3}\right)^2 && \text{Insert values for triangle} \\ &= bh^3 \left[\frac{1}{12} - \frac{1}{18} \right] && \text{Factor out common terms} \\ &= bh^3 \left[\frac{3}{36} - \frac{2}{36} \right] && \text{Common denominator} \\ \bar{I}_{x'} &= \frac{bh^3}{36} && \text{Result} \end{aligned}$$

The procedure for \bar{I}_y is similar, or you can simply reverse the roles of b and h .

Example 10.3.4 Centroidal Moment of inertia of a Semi-Circle.

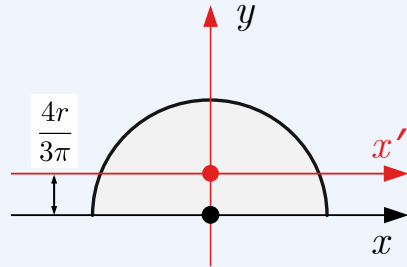

Find the centroidal moment of inertia of a semi-circle knowing that the moment of inertia about its base is

$$I_x = \frac{\pi}{8}r^4.$$

Solution. The area of a semicircle is $A = \frac{\pi r^2}{2}$ and the distance between the parallel axes is $d = \frac{4r}{3\pi}$, so

$$\begin{aligned}\bar{I}_{x'} &= I_x - Ad^2 \\ &= \frac{\pi}{8}r^4 - \left(\frac{\pi r^2}{2}\right) \left(\frac{4r}{3\pi}\right)^2 \\ \bar{I}_{x'} &= \left(\frac{\pi}{8} - \frac{8}{9\pi}\right)r^4\end{aligned}$$

Example 10.3.5 Interactive: Rectangle.

This interactive allows you to change the location and size of the grey rectangle. Try to compute both the centroidal area moment of inertia $\bar{I}_{x'}$ and $\bar{I}_{y'}$ and the area moment of inertia about the system axes I_x and I_y

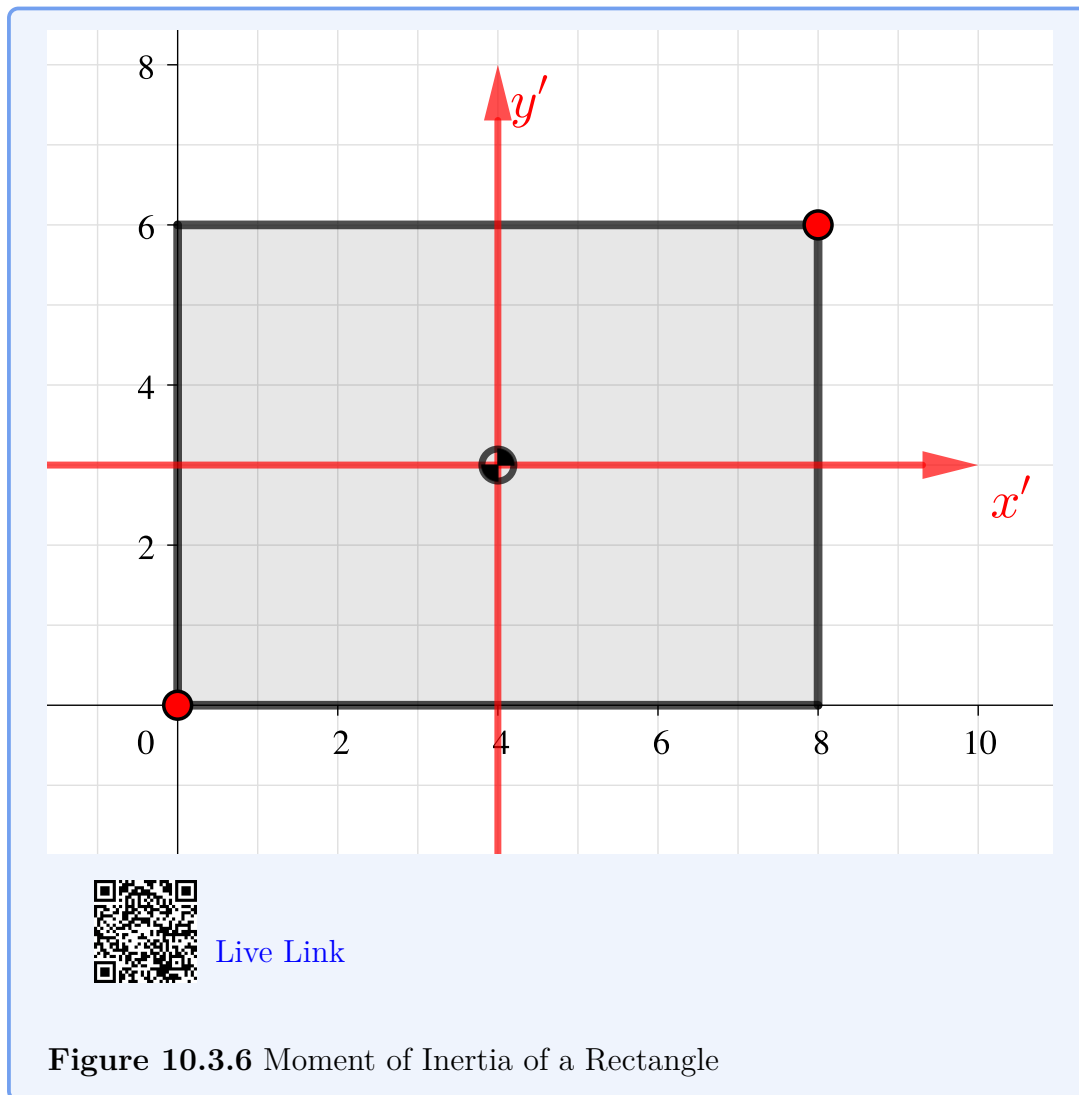

Example 10.3.7 Interactive: Semi-Circle.

Use this interactive to practice computing the area moments of inertia of the semi-circle about the centroidal x' axis, the bottom edge x'' , and the system x axis. You can change the location and size of the semicircle by moving the red points..

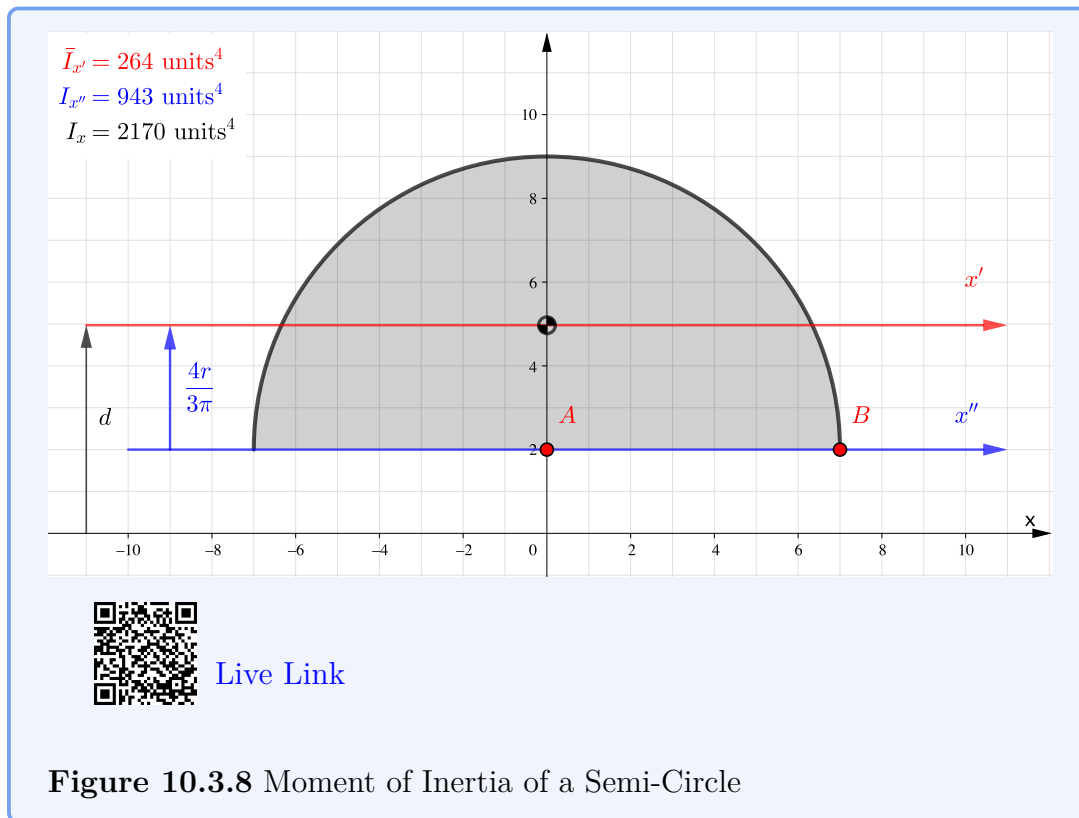

10.3.2 Moments of Inertia Table

This table summarizes the properties of the common shapes discussed previously.

Table 10.3.9 Moments of Inertia of Common Shapes

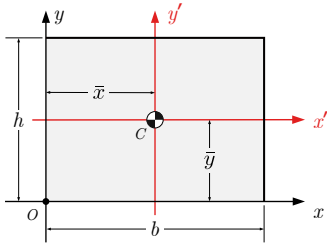
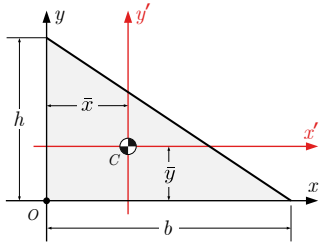
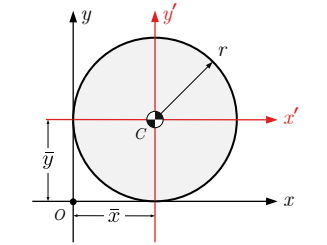
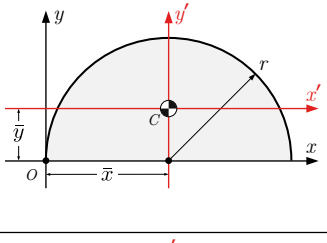
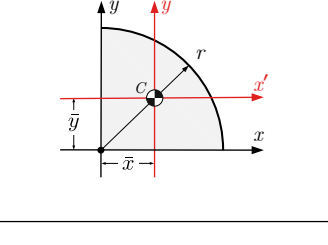
Shape	Centroid	Centroidal MOI	I_x, I_y
	$(b/2, h/2)$	$\bar{I}_{x'} = \frac{1}{12}bh^3$ $\bar{I}_{y'} = \frac{1}{12}b^3h$	$I_x = \frac{1}{3}bh^3 I_y = \frac{1}{3}b^3h$
	$(b/3, h/3)$	$\bar{I}_{x'} = \frac{1}{36}bh^3 \bar{I}_{y'} = \frac{1}{36}b^3h$	$I_x = \frac{1}{12}bh^3 I_y = \frac{1}{12}b^3h$
	(r, r)	$\bar{I}_{x'} = \bar{I}_{y'} = \frac{\pi}{4}r^4$	$I_x = I_y = \frac{5\pi}{4}r^4$
	$(r, \frac{4r}{3\pi})$	$\bar{I}_{x'} = (\frac{\pi}{8} - \frac{8}{9\pi})r^4$ $\bar{I}_{x'} \approx 0.1098 r^4$ $\bar{I}_{y'} = \frac{\pi}{8}r^4$	$I_x = \frac{\pi}{8}r^4$ $I_y = \frac{5\pi}{8}r^4$
	$(\frac{4r}{3\pi}, \frac{4r}{3\pi})$	$\bar{I}_{x'} = \frac{1}{2}(\frac{\pi}{8} - \frac{8}{9\pi})r^4$ $\bar{I}_{x'} = \bar{I}_{y'} \approx 0.0549 r^4$	$I_x = I_y = \frac{\pi}{16}r^4$

10.4 Composite Shapes

Key Questions

- Where do the common shape area moment of inertia equations come from?
- What is the parallel axis theorem?
- When do you need to apply the parallel axis theorem?
- About which point do you find the smallest area moments of inertia? What is it about this point that is so special?

In this section we will find the moment of inertia of shapes formed by combining simple shapes like rectangles, triangles and circles much the same way we did to find centroids in [Section 7.5](#).

The procedure is to divide the complex shape into its sub shapes and then use the centroidal moment of inertia formulas from [Subsection 10.3.2](#), along with the parallel axis theorem ([10.3.1](#)) to calculate the moments of inertia of parts, and finally combine them to find the moment of inertia of the original shape.

10.4.1 Composite Area Method

For a composite shape made up of n subparts, the moment of inertia of the whole shape is the sum of the moments of inertia of the individual parts, however the moment of inertia of any holes are subtracted from the total of the positive areas.

Moments of inertia are always calculated relative to a specific axis, so the moments of inertia of all the sub shapes must be calculated with respect to this same axis, which will usually involve applying the parallel axis theorem.

$$I = \sum_{i=0}^n (I)_i = \sum_{i=0}^n (\bar{I} + Ad^2)_i \quad (10.4.1)$$

The method is demonstrated in the following examples.

Example 10.4.1 Beam Design.

You have three 24 ft long wooden 2×6's and you want to nail them together them to make the stiffest possible beam. The stiffness of a beam is proportional to the moment of inertia of the beam's cross-section about a horizontal axis passing through its centroid. The actual dimensions of nominal 2×6 lumber are 1.5 in by 5.5 in.

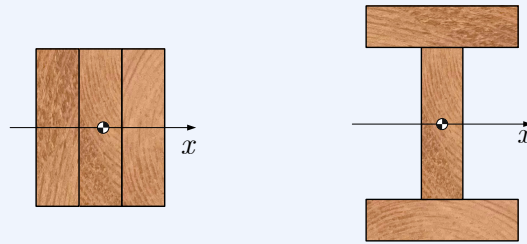

Which of the arrangements will be the stiffest, and what is the ratio of the two moments of inertia?

Solution. Given: $b = 1.5$ in, $h = 5.5$ in.

In case 1 the centroids of all three rectangles are on the x axis, so the parallel axis theorem is unnecessary.

$$\begin{aligned}
 (I_x)_1 &= \sum_{i=1}^3 \bar{I} + Ad^2 \\
 &= 3 \frac{bh^3}{12} \\
 &= \frac{(1.5)(5.5)^3}{4} \\
 (I_x)_1 &= 62.4 \text{ in}^4
 \end{aligned}$$

This value is the same as the moment of inertia of a (4.5 in \times 5.5 in) rectangle about its centroid.

In case 2, the parallel axis theorem must be used for the upper and lower rectangles, since their centroids are not on the x axis.

$$\begin{aligned}
 (I_x)_2 &= \sum_{i=1}^3 \bar{I} + Ad^2 \\
 &= \left(\frac{bh^3}{12} \right) + 2 \left[\frac{1}{12} hb^3 + (bh)(h/2 + b/2)^2 \right] \\
 &= \frac{(1.5)(5.5)^3}{12} + 2 \left[\frac{(1.5)^3(5.5)}{12} + (1.5 \times 5.5)(3.5)^2 \right] \\
 &= 20.8 \text{ in}^4 + 2 [1.547 \text{ in}^4 + 101.6 \text{ in}^4] \\
 (I_x)_2 &= 226 \text{ in}^4
 \end{aligned}$$

$$(I_x)_2 / (I_x)_1 = 3.61$$

The I-beam is about 3.6 times stiffer than the sandwich beam. This optimization of material usage is the reason we use I-beams.

Example 10.4.2 T Shape.

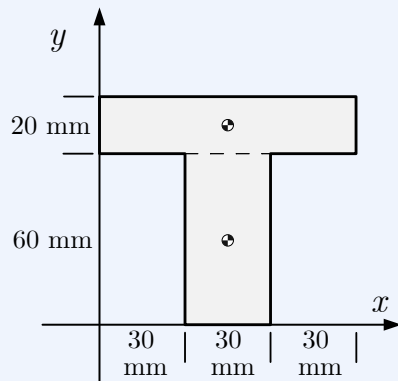

Find the moment of inertia of the T shape about the x and y axes.

Solution.1. *Strategy.*

Divide the T shape into a $30\text{ mm} \times 60\text{ mm}$ vertical rectangle (1), and a $90\text{ mm} \times 20\text{ mm}$ horizontal rectangle (2) then add the moments of inertia of the two parts.

$$I_x = (I_x)_1 + (I_x)_2 \qquad I_y = (I_y)_1 + (I_y)_2$$

2. *MOI about the x Axis.*

The bottom edge of rectangle 1 is on the x axis. Using the formula from [Subsection 10.3.2](#) gives

$$(I_x)_1 = \frac{bh^3}{3} = \frac{(30)(60)^3}{3} = 2.16 \times 10^6 \text{ mm}^4.$$

The centroid of rectangle 2 is located 70 mm above the x axis so we must use the parallel axis theorem ([10.3.1](#)), so

$$\begin{aligned} (I_x)_2 &= \bar{I} + Ad^2 \\ &= \frac{bh^3}{12} + (bh)d^2 \\ &= \frac{(90)(20)^3}{12} + (90 \times 20)(70)^2 \\ (I_x)_2 &= 8.88 \times 10^6 \text{ mm}^4 \end{aligned}$$

The moment of inertia of the entire T shape about the x axis is the sum of these two values,

$$I_x = (I_x)_1 + (I_x)_2 = 11.04 \times 10^6 \text{ mm}^4.$$

3. *MOI about the y Axis.*

We can use the same procedure to find the moment of inertia about the y axis, however it is usually more convenient to organize all the necessary information in a table rather than writing the equations explicitly.

We will use the parallel axis theorem for both rectangles with d representing the distance between the y axis and the centroid of the part. In this example d is the same for both parts, but that will not always be true.

Part	Dimensions	$\bar{I}_y = hb^3/12$	$A = bh$	d	Ad^2	$I_y = \bar{I} + Ad^2$
Units	mm	mm ⁴	mm ²	mm	mm ⁴	mm ⁴
1	$b = 30, h = 60$	135×10^3	1800	45	3.645×10^6	3.78×10^6
2	$b = 90, h = 20$	1.215×10^6	1800	45	3.645×10^6	4.86×10^6
Total						8.64×10^6

$$I_y = (I_y)_1 + (I_y)_2 = 8.64 \times 10^6 \text{ mm}^4$$

Example 10.4.3 Fillet.

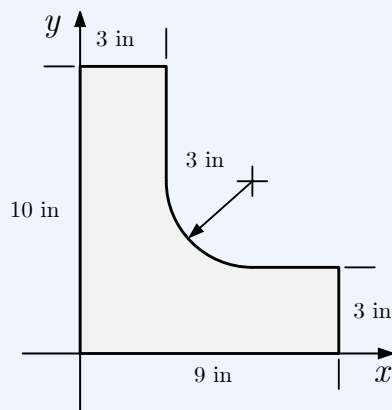

Find the moment inertia of the area about the x axis.

Solution.

1. *Strategy.*

First, divide the area into four parts:

- (a) a 9 in \times 3 in rectangle
- (b) a 6 in \times 3 in rectangle
- (c) a 3 in \times 4 in rectangle, and
- (d) a removed quarter-circle with a 3 in radius.

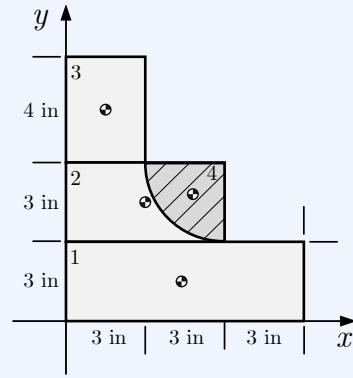

Then set up a table and apply the parallel axis theorem (10.3.1) as in the previous example. Since the quarter-circle is removed, subtract its moment of inertia from total of the other shapes.

2. *MOI about the y Axis.*

The centroidal moment of inertia of a quarter-circle, from Subsection 10.3.2 is

$$I_x = \left(\frac{\pi}{16} - \frac{4}{9\pi} \right) r^4 = 0.0549 r^4$$

The distance from the top edge of the quarter-circle down to its centroid is $\frac{4r}{3\pi} = 1.273$ in, so the distance from the x axis to its centroid is

$$d = 6 - 1.27 = 4.727 \text{ in.}$$

Fill out the table of information.

Part	Dimensions	\bar{I}_x	A	$d = \bar{y}$	Ad^2	$I_y = \bar{I} + Ad^2$
Units	inch	inch ⁴	inch ²	inch	inch ⁴	inch ⁴
1	$b = 9, h = 3$	$bh^3/12 = 20.25$	27	1.5	60.75	81
2	$b = 6, h = 3$	$bh^3/12 = 13.5$	18	4.5	364.5	378
3	$b = 3, h = 4$	$bh^3/12 = 16$	12	8	768	784
4	$r = 3$	$0.0549 r^4 = 4.45$	7.07	4.727	158.0	162.4

Take care to subtract the moment of inertia of the removed quarter-circle from the total.

$$I_x = (I_x)_1 + (I_x)_2 + (I_x)_3 - 1(I_x)_4 = 1080.6 \text{ in}^4.$$

Example 10.4.4 Concrete Pipe Casing.

The cross section of a concrete pipe casing composed of a rectangular block, a triangular wedge, and a circular pipe formed through the middle of the block is shown below.

As the pipe casing will be subject to various loads, find the area moment of inertia of the cross section about the x and y axes.

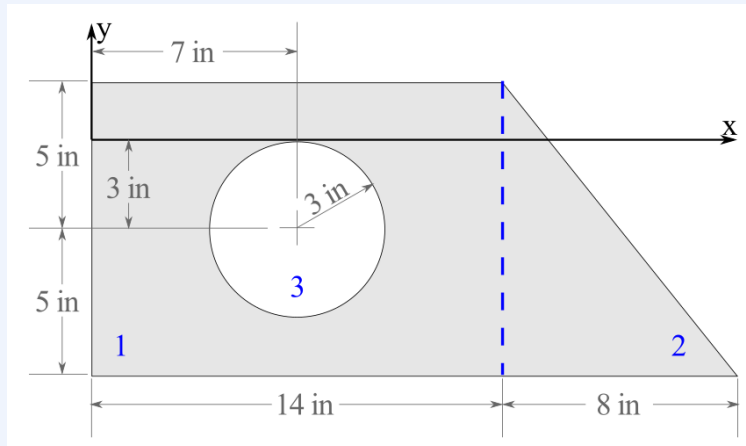
**Solution.**1. *Strategy.*

Organize all the necessary information into a table, then total the moments of inertia of the parts to get the moment of inertia of the whole shape. Remember that the hole is removed from the shape, so its contribution to the total moment of inertia is negative.

2. *Table.*

Part	A_i	d_{x_i}	d_{y_i}	$A_i d_x^2$	$A_i d_y^2$	\bar{I}_x	\bar{I}_y
Units	in ²	in	in	in ⁴	in ⁴	in ⁴	in ⁴
Rectangle 1	bh					$bh^3/12$	$b^3h/12$
$b = 14,$ $h = 10$	$= 140$	7	-3	6860	1260	$= 1167$	$= 2287$
Triangle 2	$bh/2$					$bh^3/36$	$b^3h/12$
$b = 8,$ $h = 10$	$= 40$	16.67	-4.67	11111	871.1	$= 222.2$	$= 142.2$
Circular Hole 3	$-\pi r^2$					$-\pi r^4/4$	$-\pi r^4/4$
$r = 3$	$= -28.27$	7	-3	-1385	-254.5	$= -63.62$	$= -63.62$
Total	151.7			16586	1877	1325	2365

3. *Total.*

$$\begin{aligned}
 (I_x)_1 &= [\bar{I}_x + Ad_y^2]_1 = 2427 \text{ in}^4 & (I_y)_1 &= [\bar{I}_y + Ad_x^2]_1 = 9147 \text{ in}^4 \\
 (I_x)_2 &= [\bar{I}_x + Ad_y^2]_2 = 1093 \text{ in}^4 & (I_y)_2 &= [\bar{I}_y + Ad_x^2]_2 = 11253 \text{ in}^4 \\
 (I_x)_3 &= [\bar{I}_x + Ad_y^2]_3 = -318.1 \text{ in}^4 & (I_y)_3 &= [\bar{I}_y + Ad_x^2]_3 = -1449 \text{ in}^4 \\
 I_x &= \sum (I_x)_i = 3202 \text{ in}^4 & I_y &= \sum (I_y)_i = 18951 \text{ in}^4
 \end{aligned}$$

Alternately, you could find the moments of inertia by adding the sums of the columns, since you are adding the same values together, just in a different order.

$$I_x = \sum \bar{I}_x + \sum Ad_y^2 = 3202 \text{ in}^4 \quad I_y = \sum \bar{I}_y + \sum Ad_x^2 = 18951 \text{ in}^4$$

Example 10.4.5 Interactive: Composite Rectangles.

This interactive shows a composite shape consisting of a large rectangle with a smaller rectangle subtracted. You can change the location and size of the rectangles by moving the red and blue points.

Use the interactive to see how changes to the rectangles affects the moments of inertia of this shape about the system x axis. Notice that for two-part shapes like this, the centroid of the composite shape is on the line connecting the centroids of the two parts.

For calculations, it is convenient to collect all the needed information in a table as is done here.

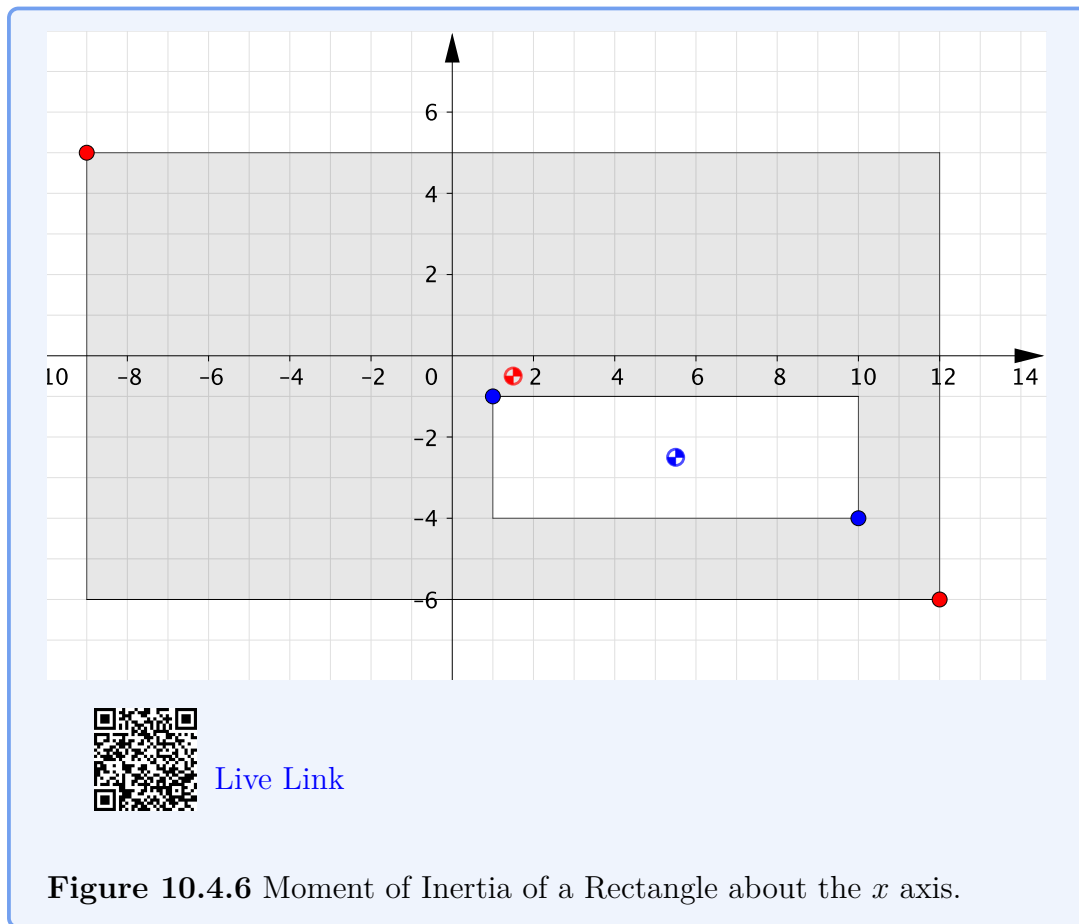

10.4.2 Structural Steel Sections

Steel is a strong, versatile, and durable material commonly used for girders, beams, and columns in steel structures such as buildings, bridges, and ships. When possible designers prefer to use prefabricated *Standardized Structural Steel* to minimize material cost.

Structural steel is available in a variety of shapes called *sections*, shown below. These include universal beams and columns (W, S), structural channels (C), equal and unequal angle sections (L), Tee shapes (T), rectangular, square and round hollow structural sections (HSS), bar, rod, and plate. All are available in a range of sizes from small to huge. Steel sections are manufactured by hot or cold rolling or fabricated by welding flat or curved steel plates together.

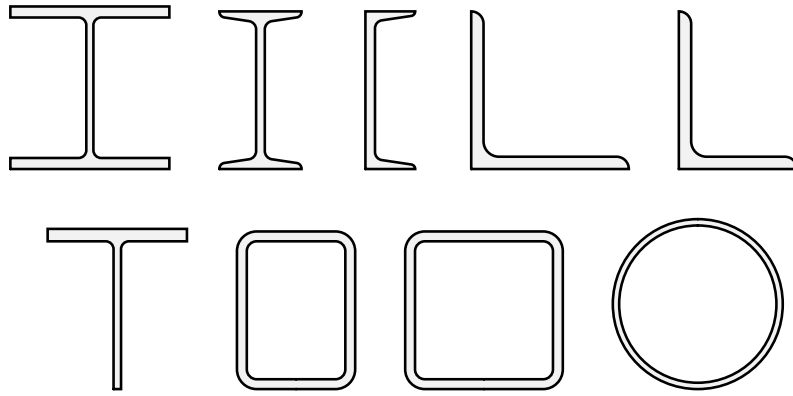

Figure 10.4.7 AISC Standard Sections: Left to right -- Wide-Flange (W), American Standard (S), Channel (C), Equal Angle (L), Unequal Angle (L), Structural Tee (T), Rectangle (HSS), Square (HSS), Round (HSS).

Designers and engineers must select the most appropriate and economical section which can support the potential tension, compression, shear, torsion and bending loads. Tables of properties of Standard Steel Sections are published by the American Institute of Steel Construction, and are used to simplify the process. The tables contain important properties of the sections, including dimensions, cross sectional area, weight per foot, and moment of inertia about vertical and horizontal axes. An abbreviated subset of the AISC tables are available in [Appendix D](#).

In this section we will use the information in the AISC tables to find the moments of inertia of standard sections and also of composite shapes incorporating standard sections.

The top and bottom pieces of an I-beam are called flanges. The middle portion is referred to as the web. The flanges take most of the internal compression and tension forces as they are located the furthest from the neutral axis, and the web mainly acts to support any shear forces and hold the two flanges apart. The transverse axis through the centroid of the cross section is called the neutral axis, and cutting plane through the beam at the neutral axis is called the neutral plane, or neutral surface. This surface does not lengthen or shorten during bending.

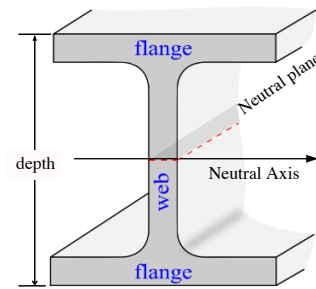
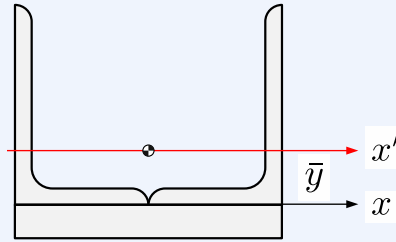

Figure 10.4.8 Beam Nomenclature

Example 10.4.9 Built-up beam.

A built-up beam consists of two L6×4×1/2 angles attached to a 8×1 plate as shown. Determine

- the distance from the x axis to the neutral axis, which passes through the centroid of the combined shape, and
- the moment of inertia of the combined shape about the neutral axis.

**Solution.**1. *Strategy.*

Determine the properties of the sub shapes with respect to the x axis, and then use them to find the neutral axis.

Use the parallel axis theorem to find the moment of inertia of the parts with respect to the neutral axis.

Take advantage of the fact that the two angles are identical and positioned similarly.

2. *Find the neutral axis.*

For one L6 × 4 × 1/2 angle, from [Section D.1](#)

$$A_L = 4.75 \text{ in}^2$$

$$\bar{y}_L = 1.98 \text{ in}$$

$$\bar{I}_L = 17.3 \text{ in}^4$$

.

For the $b = 8 \text{ in}, h = 1 \text{ in}$ rectangle

$$A_R = bh = 8 \text{ in}^2$$

$$\bar{y}_R = -h/2 = -0.5 \text{ in}$$

$$\bar{I}_R = \frac{bh^3}{12} = \frac{8}{12} = 0.667 \text{ in}^4$$

.

Find the distance to the neutral axis

$$\bar{y} = \frac{\sum A_i \bar{y}_i}{\sum A_i} = \frac{2A_L \bar{y}_L + A_R \bar{y}_R}{2A_L + A_R}$$

$$= \frac{2(4.75)(1.98) + (8)(-0.5)}{2(4.75) + 8}$$

$$\bar{y} = 0.846 \text{ in}$$

3. *Find the Moment of Inertia.*

The distance between the neutral axis and the centroids of the subparts are

$$d_R = |\bar{y} - \bar{y}_R| = |0.846 - (-0.5)| = 1.346 \text{ in}$$

$$d_L = |\bar{y} - \bar{y}_L| = |0.846 - 1.98| = 1.134 \text{ in}$$

The moment of inertia of the rectangle about the x' axis

$$(I'_x)_R = [\bar{I} + Ad^2]_R$$

$$= 0.667 + (8)(1.346)^2$$

$$= 15.16 \text{ in}^4$$

The moment of inertia of one angle about the x' axis

$$(I'_x)_L = [\bar{I} + Ad^2]_L$$

$$= 17.3 + (4.75)(1.134)^2$$

$$= 23.4 \text{ in}^4$$

The moment of inertia of the built up beam about the neutral axis

$$I_{x'} = \sum (I_{x'})_i$$

$$= 2(I_{x'})_L + (I_{x'})_R$$

$$= 2(23.4 \text{ in}^4) + 15.16 \text{ in}^4$$

$$I_{x'} = 61.98 \text{ in}^4$$

10.5 Polar Moment of Inertia

Key Questions

- How are polar moments of inertia similar and different to area moments of inertia about either a horizontal or vertical axis?

The polar moment of inertia is defined by the integral quantity

$$J_O = \int_A r^2 dA, \quad (10.5.1)$$

where r is the distance from the reference point to a differential element of area dA .

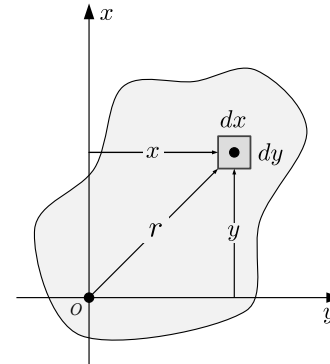

The polar moment of inertia describes the distribution of the area of a body with respect to a point in the plane of the body. Alternately, the point can be considered to be where a perpendicular axis crosses the plane of the body. The subscript on the symbol j indicates the point or axis.

There is a particularly simple relationship between the polar moment of inertia and the rectangular moments of inertia. Referring to the figure, apply the Pythagorean theorem $r^2 = x^2 + y^2$ to the definition of polar moment of inertia to get

$$\begin{aligned} J_O &= \int_A r^2 dA \\ &= \int_A (x^2 + y^2) dA \\ &= \int_A x^2 dA + \int_A y^2 dA \\ J_O &= I_x + I_y \end{aligned} \quad (10.5.2)$$

Thinking Deeper 10.5.1 Torsional Stress.

The polar moment of inertia is an important factor in the design of drive shafts. When a shaft is subjected to torsion, it experiences internal distributed shearing forces throughout its cross-section which counteract the external torsional load.

This distributed shearing force is called **shear stress**, and is usually given the symbol tau, τ . Shear stress is zero at the shaft centerline, called the **neutral axis**, and increases linearly with r to a maximum value, τ_{\max} at

the outside surface where $r = c$, so

$$\tau = \tau_{\max} \frac{r}{c}$$

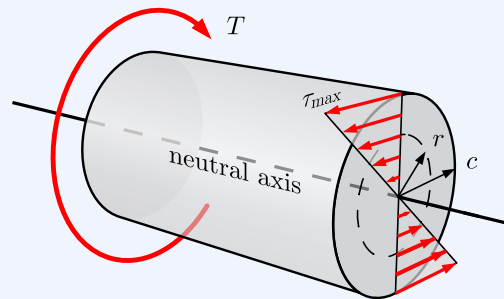

Figure 10.5.2 Section cut through a shaft, showing the shearing stresses developed to withstand an external torsion, T .

The force at any point is $dF = \tau dA$, and the moment dM exerted at any point is dF times the moment arm, r . The total moment is the integral of this quantity over the area of the cross section, and is proportional to the polar moment of inertia.

$$\begin{aligned} T &= \int dM \\ &= \int r dF \\ &= \int_A r \tau_{\max} \frac{r}{c} dA \\ &= \frac{\tau_{\max}}{c} \int_A r^2 dA \\ T &= \frac{\tau_{\max}}{c} J_O \\ \tau_{\max} &= \frac{Tc}{J_O} \end{aligned}$$

This is the relationship between the maximum stress in a circular shaft, the applied torque T , and the geometric properties of the shaft J_O and c .

10.6 Radius of Gyration

The radius of gyration is an alternate way of expressing the distribution of area away from an axis which combines the effects of the moments of inertia and cross sectional area.

The radius of gyration can be thought of as the radial distance to a thin strip which has the same area and the same moment of inertia around a specific

axis as the original shape. Compared to the moment of inertia, the radius of gyration is easier to visualize since it's a distance, rather than a distance to the fourth power.

The radius of gyration, k and the corresponding moment of inertia I are related, and both must refer to the same axis. If one is known, the other is easily found.

The radius of gyration with respect to the x and y axes and the origin are given by these formulas

$$k_x = \sqrt{\frac{I_x}{A}} \quad k_y = \sqrt{\frac{I_y}{A}} \quad k_o = \sqrt{\frac{J_o}{A}} \quad (10.6.1)$$

In engineering design, the radius of gyration is used to determine the stiffness of structural columns and estimate the critical load which will initiate column buckling.

Example 10.6.1

How are k_x , k_y , and k_o related to each other?

Solution. Start with (10.5.2)

$$\begin{aligned} J_o &= I_x + I_y && \text{divide each term by } A \\ \frac{J_o}{A} &= \frac{I_x}{A} + \frac{I_y}{A} && \text{apply definitions of } k^2 \\ k_o^2 &= k_x^2 + k_y^2 \end{aligned}$$

Example 10.6.2

Determine the polar moment of inertia and the radius of gyration of the shaded area. Give answer in terms of r , to three significant digits.

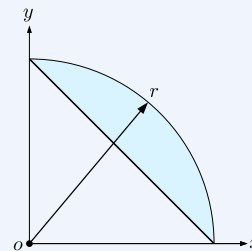

Solution. The shape consists of a quarter circle of radius r with a triangle removed. For the triangle, $b = h = r$.

$$\begin{aligned} A &= \frac{\pi r^2}{4} - \frac{(r)(r)}{2} = 0.285 r^2 \\ I_x &= \frac{\pi r^4}{16} - \frac{(r)(r^3)}{12} = 0.113 r^4 \\ I_y &= I_x \text{ by symmetry.} \\ J_o &= I_x + I_y = 2I_x = 0.226 r^4 \end{aligned}$$

$$k_o = \sqrt{\frac{J_o}{A}} = \sqrt{\frac{0.226 r^4}{0.285 r^2}} = 0.890 r$$

10.7 Products of Inertia

Key Questions

- Why do we need to quantify the product of inertia for beams?
- Why is the product of inertia of a symmetrical cross section zero?

The **product of inertia** is another integral property of area, and is defined as

$$I_{xy} = \int_A xy \, dA. \quad (10.7.1)$$

The parallel axis theorem for products of inertia is

$$I_{xy} = \bar{I}_{x'y'} + A\bar{x}\bar{y}. \quad (10.7.2)$$

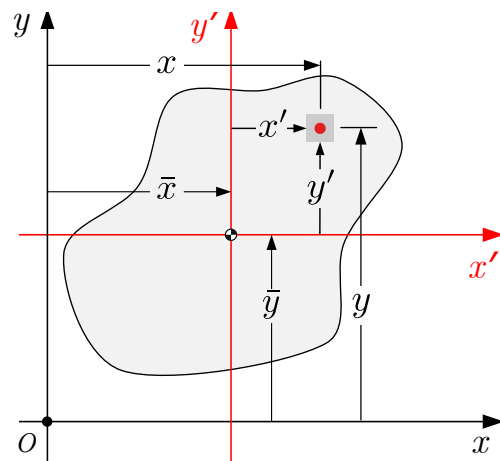

Unlike the rectangular moments of inertia, which are always positive, the product of inertia may be either positive, negative, or zero, depending on the object's shape and the orientation of the coordinate axes. The product of inertia will be zero for symmetrical objects when a coordinate axis is also an axis of symmetry.

If the product of inertia is not zero it is always possible to rotate the coordinate system until it is, in which case the new coordinate axes are called the **principle axes**. When the coordinate axes are oriented in the principle directions, the centroidal moments of inertia are maximum about one axis and minimum about the other, but neither is necessarily zero. The principle directions determine the best way to orient a beam to for maximum stiffness, and how much asymmetrical beams, like channels and angles, will twist when a load is applied.

10.8 Mass Moment of Inertia

You may recall from physics the relationship

$$T = I\alpha.$$

This formula is the rotational analog of Newton's second law $F = ma$. Here, the I represents the **mass moment of inertia**, which is the three-dimensional measure of a rigid body's resistance to angular acceleration around an axis. Mass moment of inertia plays the same role for rotational acceleration as *mass* does for linear acceleration.

Mass moment of inertia is defined by an integral equation identical to (10.1.3), except that the differential area dA is replaced with a differential element of mass, dm . The integration is conducted over a three dimensional physical object instead of a two dimensional massless area.

The units of mass moment of inertia are $[\text{mass}][\text{length}]^2$, in contrast to area moment of inertia's units of $[\text{length}]^4$.

Mass moments of inertia are covered in more detail and used extensively in the study of rigid body kinetics in *Engineering Dynamics*.

10.9 Exercises (Ch. 10)

Chapter 10 Exercises

Common Shapes	0/130
Basic Shapes from the MOI Table	0/50 Not attempted
Rectangles	0/20 Not attempted
Parallel Axis Theorem: common shapes	0/10 Not attempted
Rectangles and triangles	0/30 Not attempted
Semi and quarter circles	0/20 Not attempted
Composite Shapes	0/100
Triangle and rectangles	0/30 Not attempted
Composite shape: U or T	0/20 Not attempted
Semicircle and hole	0/20 Not attempted
Centroidal Moment of inertia: T shape	0/20 Not attempted
Box beam	0/10 Not attempted
Standard Sections	0/70
Built-up beam with angles	0/30 Not attempted
2 angles forming box beam	0/20 Not attempted
2 channels and 2 plates	0/20 Not attempted

Display options

Done

Created using Numbas v9.1, developed by Newcastle University.



Standalone
In Context

Appendix A

Notation

Notation refers to the symbols we use to represent physical quantities and variables in mathematical expressions. Notation is a tool for communication and the symbols themselves carry meaning. You will find it easier to understand the contents of engineering textbooks if you are familiar with the notation used, and can pronounce the symbols to yourself when studying the equations.

Symbol	Notes
\mathbf{F} , or \vec{F}	Vectors are written in a bold serif font. For handwritten vectors, a superimposed arrow is used.
F	Magnitudes and other scalar values are rendered in an regular italic serif font. F is the magnitude of \mathbf{F} .
$ \mathbf{F} $	Vertical bars indicate <i>absolute value</i> . The absolute value of a vector is its magnitude.
$\mathbf{F}_x, \mathbf{F}_y$	Vector component of \mathbf{F} in the x and y directions. Subscripts are used to distinguish different related values.
F_x, F_y	Scalar components of vector \mathbf{F} in the x and y directions. These are signed numbers, not vectors. Together, the sign and subscript define a vector component.
$\langle F_x, F_y \rangle$	An ordered pair of scalar components enclosed in angle brackets defines a vector.
$(F; \theta)$	An ordered pair of magnitude and direction separated with a semicolon defines a vector.
$\mathbf{i}, \mathbf{j}, \mathbf{k}$	Unit vectors in the x , y , and z directions. Pronounced ‘i hat’, ‘j hat’, etc.
$\hat{\mathbf{A}}, \hat{\lambda}$	A hat indicates a unit vector in the vector’s direction.
$\mathbf{F}_x = F_x \mathbf{i}$ $\mathbf{F}_y = F_y \mathbf{j}$	Scalar components multiplied by unit vectors are vector components.
$\mathbf{F} = \mathbf{F}_x + \mathbf{F}_y$ $= F_x \mathbf{i} + F_y \mathbf{j}$	A vector is the sum of its vector components.
$\mathbf{F} = \langle F_x, F_y \rangle$ $= \mathbf{F}_x + \mathbf{F}_y$ $= F_x \mathbf{i} + F_y \mathbf{j}$ $= (F \cos \theta) \mathbf{i} + (F \sin \theta) \mathbf{j}$ $= F (\mathbf{i} \cos \theta + \mathbf{j} \sin \theta)$ $= \mathbf{F} \langle \cos \theta, \sin \theta \rangle$	These are all equivalent representation of vector \mathbf{F} .

Figure A.0.1 Notation used in this book

Appendix B

Useful Mathematics

B.1 Distance Formula

The distance formula is used for finding the distance between two points. In two dimensions it is simply an application of the Pythagorean theorem.

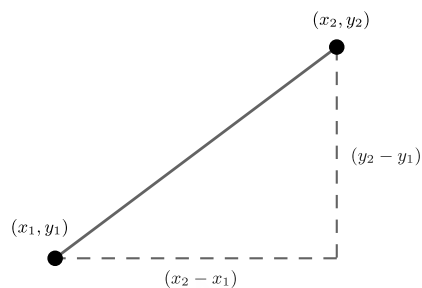

Given two points (x_1, y_1) and (x_2, y_2) the distance between them is:

$$d = \sqrt{(x_2 - x_1)^2 + (y_2 - y_1)^2} \quad (\text{B.1.1})$$

Extension of the distance formula to three dimensions is straightforward.

$$d = \sqrt{(x_2 - x_1)^2 + (y_2 - y_1)^2 + (z_2 - z_1)^2} \quad (\text{B.1.2})$$

B.2 Right Triangle Trigonometry

A **right triangle** is a triangle containing a 90° angle.

The side opposite to the right angle is called the **hypotenuse**.

The other two angles add to 90° and are called **complementary angles**.

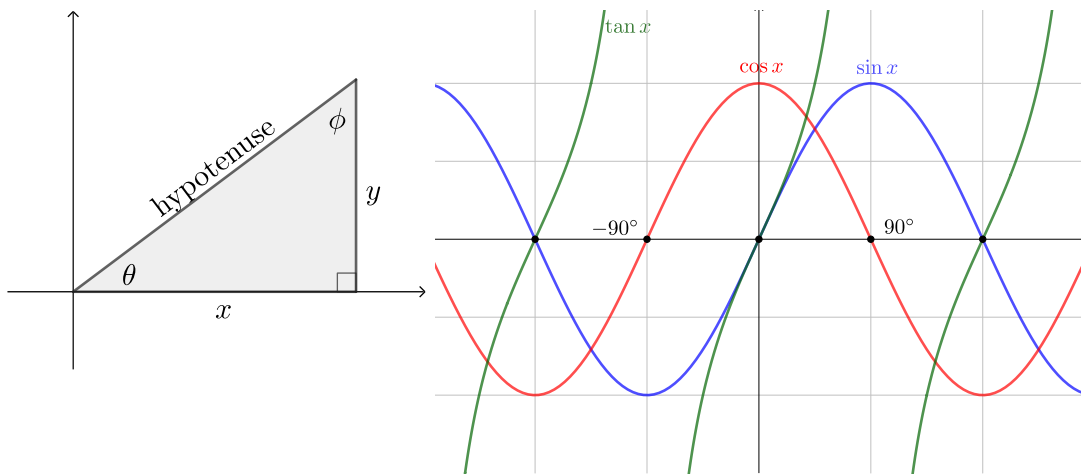

The relationship between the sides and angles of a right triangle are given by the three basic trig relations which may be recalled with the mnemonic **SOH-CAH-TOA**.

$$\sin \theta = \frac{\text{opposite}}{\text{hypotenuse}} \quad \cos \theta = \frac{\text{adjacent}}{\text{hypotenuse}} \quad \tan \theta = \frac{\text{opposite}}{\text{adjacent}}$$

and their inverses,

$$\theta = \sin^{-1} \left(\frac{\text{opposite}}{\text{hypotenuse}} \right) \quad \theta = \cos^{-1} \left(\frac{\text{adjacent}}{\text{hypotenuse}} \right) \quad \theta = \tan^{-1} \left(\frac{\text{opposite}}{\text{adjacent}} \right)$$

Facts. The following statements regarding the trig functions and triangles are always true, and remembering them will help you avoid errors.

- sin, cos and tan are functions of an angle and their values are unitless ratios of lengths.
- The inverse trig functions are functions of unitless ratios and their results are angles.
- The sine of an angle equals the cosine of its complement and vice-versa.
- The sine and cosine of any angle is always a unitless number between -1 and 1, inclusive.
- The sine, cosine, and tangent of angles between 0 and 90° are always positive.
- The inverse trig functions of positive numbers will always yield angles between 0 and 90°
- The legs of a right triangle are always shorter than the hypotenuse.
- Only right triangles have a hypotenuse.

Hints. Here are some useful tips for angle calculations

- Take care that your calculator is set in *degrees mode* for this course.
- Always work with angles between 0° and 90° and use positive arguments for the inverse trig functions.
- Following this advice will avoid unwanted signs and incorrect directions caused because $\frac{-a}{b} = \frac{a}{-b}$, and $\frac{a}{b} = \frac{-a}{-b}$ and the calculator can't distinguish between them.

B.3 Oblique Triangle Trigonometry

An oblique triangle is any triangle which does not contain a right angle. As such, the rules of [Right Triangle Trigonometry](#) do not apply!

For an oblique triangle labeled as shown, the relations between the sides and angles are given by the **Law of Sines** and the **Law of Cosines**.

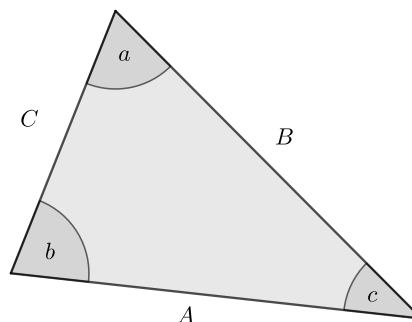

B.3.1 Law of Sines

$$\frac{\sin a}{A} = \frac{\sin b}{B} = \frac{\sin c}{C} \quad (\text{B.3.1})$$

The law of Sines is used when you know the length of one side, the angle opposite it, and one additional angle (SAA) or side (SSA). If this is not the case use the Law of Cosines.

Take care in the (SSA) situation. This is known as the **ambiguous case**, and you must be alert for it. It occurs because there are two angles between 0 and 180° with the same sine. When you use your calculator to find $\sin^{-1}(x)$ it may return the **supplement** of the angle you want. In fact, there may be two possible solutions to the problem, or one or both solutions may be physically impossible and must be discarded.

If one of the angles is 90° , then the Law of Sines simplifies to the definitions of sine and cosine since the $\sin(90^\circ) = 1$.

B.3.2 Law of Cosines

$$A^2 = B^2 + C^2 - 2BC \cos a \quad (\text{B.3.2})$$

$$B^2 = A^2 + C^2 - 2AC \cos b \quad (\text{B.3.3})$$

$$C^2 = A^2 + B^2 - 2AB \cos c \quad (\text{B.3.4})$$

The Law of Cosines is used when you know two sides and the included angle (SAS), or when you know all three sides but no angles (SSS). In any other situation, use the Law of Sines.

If one of the angles is 90° the Law of Cosines simplifies to the Pythagorean Theorem since $\cos(90^\circ) = 0$.

Appendix C

Properties of Shapes

C.1 Centroids of Common Shapes

Table C.1.1 Centroids of Common Shapes

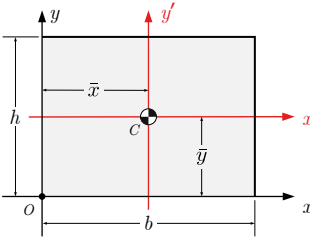
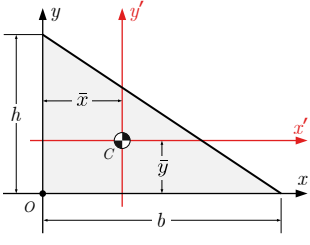
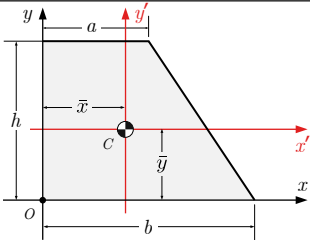
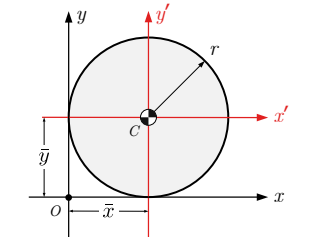
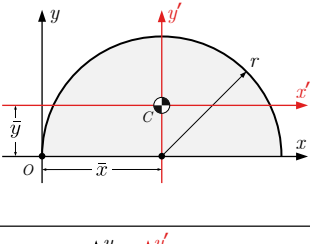
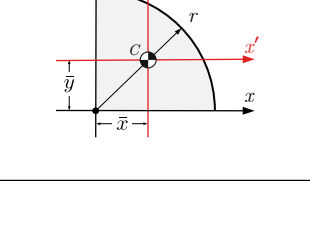
Shape	Area	\bar{x}	\bar{y}
	$A = bh$	$b/2$	$h/2$
	$\frac{bh}{2}$	$b/3$	$h/3$
	$\frac{(a+b)h}{2}$	$\frac{a^2 + ab + b^2}{3(a+b)}$	$\frac{h(2a+b)}{3(a+b)}$
	πr^2	r	r
	$\frac{\pi r^2}{2}$	r	$\frac{4r}{3\pi}$
	$\frac{\pi r^2}{4}$	$\frac{4r}{3\pi}$	$\frac{4r}{3\pi}$

C.2 Moment of Inertia of Common Shapes

Table C.2.1 Moments of Inertia of Common Shapes

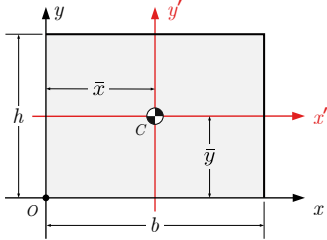
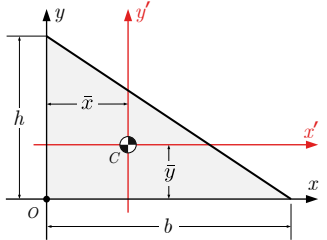
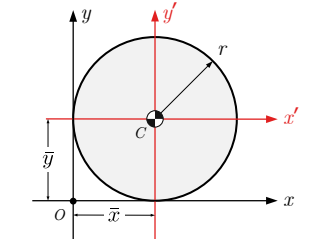
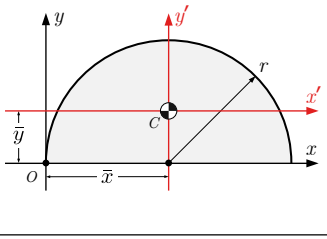
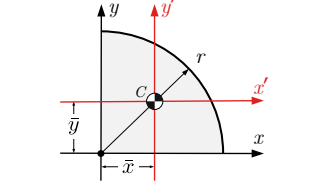
Shape	Centroid	Centroidal MOI	I_x, I_y
	$(b/2, h/2)$	$\bar{I}_{x'} = \frac{1}{12}bh^3$ $\bar{I}_{y'} = \frac{1}{12}b^3h$	$I_x = \frac{1}{3}bh^3 I_y = \frac{1}{3}b^3h$
	$(b/3, h/3)$	$\bar{I}_{x'} = \frac{1}{36}bh^3 \bar{I}_{y'} = \frac{1}{36}b^3h$	$I_x = \frac{1}{12}bh^3 I_y = \frac{1}{12}b^3h$
	(r, r)	$\bar{I}_{x'} = \bar{I}_{y'} = \frac{\pi}{4}r^4$	$I_x = I_y = \frac{5\pi}{4}r^4$
	$(r, \frac{4r}{3\pi})$	$\bar{I}_{x'} = (\frac{\pi}{8} - \frac{8}{9\pi})r^4$ $\bar{I}_{x'} \approx 0.1098 r^4$ $\bar{I}_{y'} = \frac{\pi}{8}r^4$	$I_x = \frac{\pi}{8}r^4$ $I_y = \frac{5\pi}{8}r^4$
	$(\frac{4r}{3\pi}, \frac{4r}{3\pi})$	$\bar{I}_{x'} = \frac{1}{2}(\frac{\pi}{8} - \frac{8}{9\pi})r^4$ $\bar{I}_{x'} = \bar{I}_{y'} \approx 0.0549 r^4$	$I_x = I_y = \frac{\pi}{16}r^4$

¹See [Example 7.7.14](#) for proof. $\frac{4r}{3\pi} \approx 0.424 r$

Appendix D

Properties of Steel Sections

D.1 Angles

D.1.1 Angle Section-US

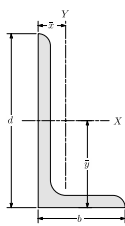

Description $d \times b \times t$	W lb/ft	A in ²	b in	d in	t in	\bar{x} in	\bar{y} in	\bar{I}_{xx} in ⁴	\bar{I}_{yy} in ⁴
L6×6×1	37.4	11	6	6	1	1.86	1.86	35.4	35.4
L6×6×7/8	33.1	9.75	6	6	0.875	1.81	1.81	31.9	31.9
L6×6×3/4	28.7	8.46	6	6	0.75	1.77	1.77	28.1	28.1
L6×6×5/8	24.2	7.13	6	6	0.625	1.72	1.72	24.1	24.1
L6×6×9/16	21.9	6.45	6	6	0.563	1.7	1.7	22	22
L6×6×1/2	19.6	5.77	6	6	0.5	1.67	1.67	19.9	19.9
L6×6×7/16	17.2	5.08	6	6	0.438	1.65	1.65	17.6	17.6
L6×6×3/8	14.9	4.38	6	6	0.375	1.62	1.62	15.4	15.4
L6×6×5/16	12.4	3.67	6	6	0.313	1.6	1.6	13	13
L6×4×7/8	27.2	8	6	4	0.875	1.12	2.12	27.7	9.7
L6×4×3/4	23.6	6.94	6	4	0.75	1.07	2.07	24.5	8.63
L6×4×5/8	20	5.86	6	4	0.625	1.03	2.03	21	7.48
L6×4×9/16	18.1	5.31	6	4	0.563	1	2	19.2	6.86
L6×4×1/2	16.2	4.75	6	4	0.5	0.981	1.98	17.3	6.22
L6×4×7/16	14.3	4.18	6	4	0.438	0.957	1.95	15.4	5.56
L6×4×3/8	12.3	3.61	6	4	0.375	0.933	1.93	13.4	4.86
L6×4×5/16	10.3	3.03	6	4	0.313	0.908	1.9	11.4	4.13
L6×3-1/2×1/2	15.3	4.5	6	3.5	0.5	0.829	2.07	16.6	4.24
L6×3-1/2×3/8	11.7	3.44	6	3.5	0.375	0.781	2.02	12.9	3.33
L6×3-1/2×5/16	9.8	2.89	6	3.5	0.313	0.756	2	10.9	2.84
L5×5×7/8	27.2	8	5	5	0.875	1.56	1.56	17.8	17.8
L5×5×3/4	23.6	6.98	5	5	0.75	1.52	1.52	15.7	15.7
L5×5×5/8	20	5.9	5	5	0.625	1.47	1.47	13.6	13.6
L5×5×1/2	16.2	4.79	5	5	0.5	1.42	1.42	11.3	11.3
L5×5×7/16	14.3	4.22	5	5	0.438	1.4	1.4	10	10
L5×5×3/8	12.3	3.65	5	5	0.375	1.37	1.37	8.76	8.76
L5×5×5/16	10.3	3.07	5	5	0.313	1.35	1.35	7.44	7.44
L5×3-1/2×3/4	19.8	5.85	5	3.5	0.75	0.993	1.74	13.9	5.52
L5×3-1/2×5/8	16.8	4.93	5	3.5	0.625	0.947	1.69	12	4.8
L5×3-1/2×1/2	13.6	4	5	3.5	0.5	0.901	1.65	10	4.02
L5×3-1/2×3/8	10.4	3.05	5	3.5	0.375	0.854	1.6	7.75	3.15
L5×3-1/2×5/16	8.7	2.56	5	3.5	0.313	0.829	1.57	6.58	2.69
L5×3-1/2×1/4	7	2.07	5	3.5	0.25	0.804	1.55	5.36	2.2
L5×3×1/2	12.8	3.75	5	3	0.5	0.746	1.74	9.43	2.55
L5×3×7/16	11.3	3.31	5	3	0.438	0.722	1.72	8.41	2.29
L5×3×3/8	9.8	2.86	5	3	0.375	0.698	1.69	7.35	2.01

D.1.2 Angle Section-SI

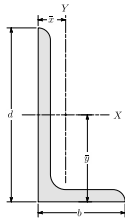

Description $d \times b \times t$	W kg/m	A mm ²	b mm	d mm	t mm	\bar{x} mm	\bar{y} mm	\bar{I}_{xx} 10 ⁶ mm ⁴	\bar{I}_{yy} 10 ⁶ mm ⁴
L152×152×22.2	49.3	6290	152	152	22.2	46	46	13.3	13.3
L152×152×19	42.7	5460	152	152	19.1	45	45	11.7	11.7
L152×152×15.9	36	4600	152	152	15.9	43.7	43.7	10	10
L152×152×14.3	32.6	4160	152	152	14.3	43.2	43.2	9.16	9.16
L152×152×12.7	29.2	3720	152	152	12.7	42.4	42.4	8.28	8.28
L152×152×11.1	25.6	3280	152	152	11.1	41.9	41.9	7.33	7.33
L152×152×9.5	22.2	2830	152	152	9.53	41.1	41.1	6.41	6.41
L152×152×7.9	18.5	2370	152	152	7.94	40.6	40.6	5.41	5.41
L152×102×22.2	40.3	5160	152	102	22.2	28.4	53.8	11.5	4.04
L152×102×19	35	4480	152	102	19.1	27.2	52.6	10.2	3.59
L152×102×15.9	29.6	3780	152	102	15.9	26.2	51.6	8.74	3.11
L152×102×14.3	26.9	3430	152	102	14.3	25.4	50.8	7.99	2.86
L152×102×12.7	24	3060	152	102	12.7	24.9	50.3	7.2	2.59
L152×102×11.1	21.2	2700	152	102	11.1	24.3	49.5	6.41	2.31
L152×102×9.5	18.2	2330	152	102	9.53	23.7	49	5.58	2.02
L152×102×7.9	15.3	1950	152	102	7.94	23.1	48.3	4.75	1.72
L152×89×12.7	22.7	2900	152	88.9	12.7	21.1	52.6	6.91	1.76
L152×89×9.5	17.3	2220	152	88.9	9.53	19.8	51.3	5.37	1.39
L152×89×7.9	14.5	1860	152	88.9	7.94	19.2	50.8	4.54	1.18
L127×127×22.2	40.5	5160	127	127	22.2	39.6	39.6	7.41	7.41
L127×127×19	35.1	4500	127	127	19.1	38.6	38.6	6.53	6.53
L127×127×15.9	29.8	3810	127	127	15.9	37.3	37.3	5.66	5.66
L127×127×12.7	24.1	3090	127	127	12.7	36.1	36.1	4.7	4.7
L127×127×11.1	21.3	2720	127	127	11.1	35.6	35.6	4.16	4.16
L127×127×9.5	18.3	2350	127	127	9.53	34.8	34.8	3.65	3.65
L127×127×7.9	15.3	1980	127	127	7.94	34.3	34.3	3.1	3.1
L127×89×19	29.3	3770	127	88.9	19.1	25.2	44.2	5.79	2.3
L127×89×15.9	24.9	3180	127	88.9	15.9	24.1	42.9	4.99	2
L127×89×12.7	20.2	2580	127	88.9	12.7	22.9	41.9	4.16	1.67
L127×89×9.5	15.4	1970	127	88.9	9.53	21.7	40.6	3.23	1.31
L127×89×7.9	12.9	1650	127	88.9	7.94	21.1	39.9	2.74	1.12
L127×89×6.4	10.4	1340	127	88.9	6.35	20.4	39.4	2.23	0.916
L127×76×12.7	19	2420	127	76.2	12.7	18.9	44.2	3.93	1.06
L127×76×11.1	16.7	2140	127	76.2	11.1	18.3	43.7	3.5	0.953
L127×76×9.5	14.5	1850	127	76.2	9.53	17.7	42.9	3.06	0.837
L127×76×7.9	12.1	1550	127	76.2	7.94	17.1	42.4	2.6	0.716
L127×76×6.4	9.8	1250	127	76.2	6.35	16.5	41.7	2.12	0.587
L102×102×19	27.5	3510	102	102	19.1	32.3	32.3	3.17	3.17
L102×102×15.9	23.4	2970	102	102	15.9	31	31	2.76	2.76
L102×102×12.7	19	2420	102	102	12.7	30	30	2.3	2.3
L102×102×11.1	16.8	2130	102	102	11.1	29.2	29.2	2.05	2.05
L102×102×9.5	14.6	1850	102	102	9.53	28.7	28.7	1.8	1.8
L102×102×7.9	12.2	1550	102	102	7.94	28.2	28.2	1.53	1.53
L102×102×6.4	9.8	1250	102	102	6.35	27.4	27.4	1.25	1.25
L102×89×12.7	17.6	2260	102	88.9	12.7	25.2	31.5	2.21	1.57
L102×89×9.5	13.5	1730	102	88.9	9.53	24.1	30.5	1.73	1.23
L102×89×7.9	11.4	1450	102	88.9	7.94	23.4	29.7	1.47	1.05
L102×89×6.4	9.2	1170	102	88.9	6.35	22.8	29	1.2	0.862

D.2 Channels

D.2.1 Channel Section-US

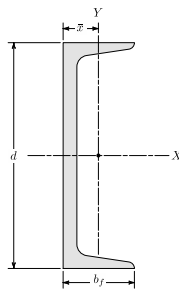

Description $d \times W$	W lb/ft	A in ²	d in	b_f in	t_w in	t_f in	\bar{x} in	\bar{I}_{xx} in ⁴	\bar{I}_{yy} in ⁴
C15×50	50	14.7	15	3.72	0.716	0.65	0.799	404	11
C15×40	40	11.8	15	3.52	0.52	0.65	0.778	348	9.17
C15×33.9	33.9	10	15	3.4	0.4	0.65	0.788	315	8.07
C12×30	30	8.81	12	3.17	0.51	0.501	0.674	162	5.12
C12×25	25	7.34	12	3.05	0.387	0.501	0.674	144	4.45
C12×20.7	20.7	6.08	12	2.94	0.282	0.501	0.698	129	3.86
C10×30	30	8.81	10	3.03	0.673	0.436	0.649	103	3.93
C10×25	25	7.35	10	2.89	0.526	0.436	0.617	91.1	3.34
C10×20	20	5.87	10	2.74	0.379	0.436	0.606	78.9	2.8
C10×15.3	15.3	4.48	10	2.6	0.24	0.436	0.634	67.3	2.27
C9×20	20	5.87	9	2.65	0.448	0.413	0.583	60.9	2.41
C9×15	15	4.4	9	2.49	0.285	0.413	0.586	51	1.91
C9×13.4	13.4	3.94	9	2.43	0.233	0.413	0.601	47.8	1.75
C8×18.75	18.75	5.51	8	2.53	0.487	0.39	0.565	43.9	1.97
C8×13.75	13.75	4.03	8	2.34	0.303	0.39	0.554	36.1	1.52
C8×11.5	11.5	3.37	8	2.26	0.22	0.39	0.572	32.5	1.31
C7×14.75	14.75	4.33	7	2.3	0.419	0.366	0.532	27.2	1.37
C7×12.25	12.25	3.59	7	2.19	0.314	0.366	0.525	24.2	1.16
C7×9.8	9.8	2.87	7	2.09	0.21	0.366	0.541	21.2	0.957
C6×13	13	3.82	6	2.16	0.437	0.343	0.514	17.3	1.05
C6×10.5	10.5	3.07	6	2.03	0.314	0.343	0.5	15.1	0.86
C6×8.2	8.2	2.39	6	1.92	0.2	0.343	0.512	13.1	0.687
C5×9	9	2.64	5	1.89	0.325	0.32	0.478	8.89	0.624
C5×6.7	6.7	1.97	5	1.75	0.19	0.32	0.484	7.48	0.47
C4×7.25	7.25	2.13	4	1.72	0.321	0.296	0.459	4.58	0.425
C4×6.25	6.25	1.84	4	1.65	0.247	0.296	0.453	4.19	0.374
C4×5.4	5.4	1.58	4	1.58	0.184	0.296	0.457	3.85	0.312
C4×4.5	4.5	1.34	4	1.52	0.125	0.296	0.473	3.53	0.265
C3×6	6	1.76	3	1.6	0.356	0.273	0.455	2.07	0.3
C3×5	5	1.47	3	1.5	0.258	0.273	0.439	1.85	0.241
C3×4.1	4.1	1.2	3	1.41	0.17	0.273	0.437	1.65	0.191
C3×3.5	3.5	1.09	3	1.37	0.132	0.273	0.443	1.57	0.169

D.2.2 Channel Section-SI

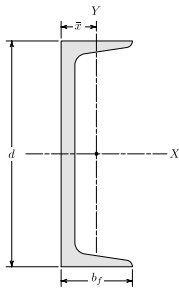

Description $d \times W$	W kg/m	A mm ²	d mm	b_f mm	t_w mm	t_f mm	\bar{x} mm	\bar{I}_{xx} 10 ⁶ mm ⁴	\bar{I}_{yy} 10 ⁶ mm ⁴
C380×74	74	9480	381	94.5	18.2	16.5	20.3	168	4.58
C380×60	60	7610	381	89.4	13.2	16.5	19.8	145	3.82
C380×50.4	50.4	6450	381	86.4	10.2	16.5	20	131	3.36
C310×45	45	5680	305	80.5	13	12.7	17.1	67.4	2.13
C310×37	37	4740	305	77.5	9.83	12.7	17.1	59.9	1.85
C310×30.8	30.8	3920	305	74.7	7.16	12.7	17.7	53.7	1.61
C250×45	45	5680	254	77	17.1	11.1	16.5	42.9	1.64
C250×37	37	4740	254	73.4	13.4	11.1	15.7	37.9	1.39
C250×30	30	3790	254	69.6	9.63	11.1	15.4	32.8	1.17
C250×22.8	22.8	2890	254	66	6.1	11.1	16.1	28	0.945
C230×30	30	3790	229	67.3	11.4	10.5	14.8	25.3	1
C230×22	22	2840	229	63.2	7.24	10.5	14.9	21.2	0.795
C230×19.9	19.9	2540	229	61.7	5.92	10.5	15.3	19.9	0.728
C200×27.9	27.9	3550	203	64.3	12.4	9.91	14.4	18.3	0.82
C200×20.5	20.5	2600	203	59.4	7.7	9.91	14.1	15	0.633
C200×17.1	17.1	2170	203	57.4	5.59	9.91	14.5	13.5	0.545
C180×22	22	2790	178	58.4	10.6	9.3	13.5	11.3	0.57
C180×18.2	18.2	2320	178	55.6	7.98	9.3	13.3	10.1	0.483
C180×14.6	14.6	1850	178	53.1	5.33	9.3	13.7	8.82	0.398
C150×19.3	19.3	2460	152	54.9	11.1	8.71	13.1	7.2	0.437
C150×15.6	15.6	1980	152	51.6	7.98	8.71	12.7	6.29	0.358
C150×12.2	12.2	1540	152	48.8	5.08	8.71	13	5.45	0.286
C130×13	13	1700	127	48	8.26	8.13	12.1	3.7	0.26
C130×10.4	10.4	1270	127	44.5	4.83	8.13	12.3	3.11	0.196
C100×10.8	10.8	1370	102	43.7	8.15	7.52	11.7	1.91	0.177
C100×9.3	9.3	1190	102	41.9	6.27	7.52	11.5	1.74	0.156
C100×8	8	1020	102	40.1	4.67	7.52	11.6	1.6	0.13
C100×6.7	6.7	865	102	38.6	3.18	7.52	12	1.47	0.11
C75×8.9	8.9	1140	76.2	40.6	9.04	6.93	11.6	0.862	0.125
C75×7.4	7.4	948	76.2	38.1	6.55	6.93	11.2	0.77	0.1
C75×6.1	6.1	774	76.2	35.8	4.32	6.93	11.1	0.687	0.0795
C75×5.2	5.2	703	76.2	34.8	3.35	6.93	11.3	0.653	0.0703

D.3 Standard Sections

D.3.1 Standard Section-US

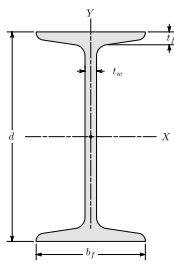

Description $d \times W$	W lb/ft	A in ²	d in	b_f in	t_w in	t_f in	\bar{I}_{xx} in ⁴	\bar{I}_{yy} in ⁴
S24×121	121	35.5	24.5	8.05	0.8	1.09	3160	83
S24×106	106	31.1	24.5	7.87	0.62	1.09	2940	76.8
S24×100	100	29.3	24	7.25	0.745	0.87	2380	47.4
S24×90	90	26.5	24	7.13	0.625	0.87	2250	44.7
S24×80	80	23.5	24	7	0.5	0.87	2100	42
S20×96	96	28.2	20.3	7.2	0.8	0.92	1670	49.9
S20×86	86	25.3	20.3	7.06	0.66	0.92	1570	46.6
S20×75	75	22	20	6.39	0.635	0.795	1280	29.5
S20×66	66	19.4	20	6.26	0.505	0.795	1190	27.5
S18×70	70	20.5	18	6.25	0.711	0.691	923	24
S18×54.7	54.7	16	18	6	0.461	0.691	801	20.7
S15×50	50	14.7	15	5.64	0.55	0.622	485	15.6
S15×42.9	42.9	12.6	15	5.5	0.411	0.622	446	14.3
S12×50	50	14.7	12	5.48	0.687	0.659	303	15.6
S12×40.8	40.8	11.9	12	5.25	0.462	0.659	270	13.5
S12×35	35	10.2	12	5.08	0.428	0.544	228	9.84
S12×31.8	31.8	9.31	12	5	0.35	0.544	217	9.33
S10×35	35	10.3	10	4.94	0.594	0.491	147	8.3
S10×25.4	25.4	7.45	10	4.66	0.311	0.491	123	6.73
S8×23	23	6.76	8	4.17	0.441	0.425	64.7	4.27
S8×18.4	18.4	5.4	8	4	0.271	0.425	57.5	3.69
S6×17.25	17.25	5.05	6	3.57	0.465	0.359	26.2	2.29
S6×12.5	12.5	3.66	6	3.33	0.232	0.359	22	1.8
S5×10	10	2.93	5	3	0.214	0.326	12.3	1.19
S4×9.5	9.5	2.79	4	2.8	0.326	0.293	6.76	0.887
S4×7.7	7.7	2.26	4	2.66	0.193	0.293	6.05	0.748
S3×7.5	7.5	2.2	3	2.51	0.349	0.26	2.91	0.578
S3×5.7	5.7	1.66	3	2.33	0.17	0.26	2.5	0.447

D.3.2 Standard Section-SI

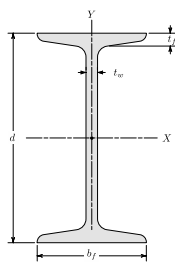

Description $d \times W$	W kg/m	A mm ²	d mm	b_f mm	t_w mm	t_f mm	\bar{I}_{xx} 10 ⁶ mm ⁴	\bar{I}_{yy} 10 ⁶ mm ⁴
S610×180	180	22900	622	204	20.3	27.7	1320	34.5
S610×158	158	20100	622	200	15.7	27.7	1220	32
S610×149	149	18900	610	184	18.9	22.1	991	19.7
S610×134	134	17100	610	181	15.9	22.1	937	18.6
S610×119	119	15200	610	178	12.7	22.1	874	17.5
S510×143	143	18200	516	183	20.3	23.4	695	20.8
S510×128	128	16300	516	179	16.8	23.4	653	19.4
S510×112	112	14200	508	162	16.1	20.2	533	12.3
S510×98.2	98.2	12500	508	159	12.8	20.2	495	11.4
S460×104	104	13200	457	159	18.1	17.6	384	9.99
S460×81.4	81.4	10300	457	152	11.7	17.6	333	8.62
S380×74	74	9480	381	143	14	15.8	202	6.49
S380×64	64	8130	381	140	10.4	15.8	186	5.95
S310×74	74	9480	305	139	17.4	16.7	126	6.49
S310×60.7	60.7	7680	305	133	11.7	16.7	112	5.62
S310×52	52	6580	305	129	10.9	13.8	94.9	4.1
S310×47.3	47.3	6010	305	127	8.89	13.8	90.3	3.88
S250×52	52	6650	254	125	15.1	12.5	61.2	3.45
S250×37.8	37.8	4810	254	118	7.9	12.5	51.2	2.8
S200×34	34	4360	203	106	11.2	10.8	26.9	1.78
S200×27.4	27.4	3480	203	102	6.88	10.8	23.9	1.54
S150×25.7	25.7	3260	152	90.7	11.8	9.12	10.9	0.953
S150×18.6	18.6	2360	152	84.6	5.89	9.12	9.16	0.749
S130×15	15	1890	127	76.2	5.44	8.28	5.12	0.495
S100×14.1	14.1	1800	102	71.1	8.28	7.44	2.81	0.369
S100×11.5	11.5	1460	102	67.6	4.9	7.44	2.52	0.311
S75×11.2	11.2	1420	76.2	63.8	8.86	6.6	1.21	0.241
S75×8.5	8.5	1070	76.2	59.2	4.32	6.6	1.04	0.186

D.4 Wide Flange Sections

D.4.1 Wide Flange Section-US

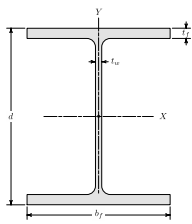

Description $d \times W$	W lb/ft	A in ²	d in	b_f in	t_w in	t_f in	\bar{I}_{xx} in ⁴	\bar{I}_{yy} in ⁴
W44×335	335	98.5	44	15.9	1.03	1.77	31100	1200
W44×290	290	85.4	43.6	15.8	0.865	1.58	27000	1040
W44×262	262	77.2	43.3	15.8	0.785	1.42	24100	923
W44×230	230	67.8	42.9	15.8	0.71	1.22	20800	796
W40×655	655	193	43.6	16.9	1.97	3.54	56500	2870
W40×593	593	174	43	16.7	1.79	3.23	50400	2520
W40×503	503	148	42.1	16.4	1.54	2.76	41600	2040
W40×431	431	127	41.3	16.2	1.34	2.36	34800	1690
W40×397	397	117	41	16.1	1.22	2.2	32000	1540
W40×372	372	110	40.6	16.1	1.16	2.05	29600	1420
W40×362	362	106	40.6	16	1.12	2.01	28900	1380
W40×324	324	95.3	40.2	15.9	1	1.81	25600	1220
W40×297	297	87.3	39.8	15.8	0.93	1.65	23200	1090
W40×277	277	81.5	39.7	15.8	0.83	1.58	21900	1040
W40×249	249	73.5	39.4	15.8	0.75	1.42	19600	926
W40×215	215	63.5	39	15.8	0.65	1.22	16700	803
W40×199	199	58.8	38.7	15.8	0.65	1.07	14900	695
W40×392	392	116	41.6	12.4	1.42	2.52	29900	803
W40×331	331	97.7	40.8	12.2	1.22	2.13	24700	644
W40×327	327	95.9	40.8	12.1	1.18	2.13	24500	640
W40×294	294	86.2	40.4	12	1.06	1.93	21900	562
W40×278	278	82.3	40.2	12	1.03	1.81	20500	521
W40×264	264	77.4	40	11.9	0.96	1.73	19400	493
W40×235	235	69.1	39.7	11.9	0.83	1.58	17400	444
W40×211	211	62.1	39.4	11.8	0.75	1.42	15500	390
W40×183	183	53.3	39	11.8	0.65	1.2	13200	331
W40×167	167	49.3	38.6	11.8	0.65	1.03	11600	283
W40×149	149	43.8	38.2	11.8	0.63	0.83	9800	229
W36×925	925	272	43.1	18.6	3.02	4.53	73000	4940
W36×853	853	251	43.1	18.2	2.52	4.53	70000	4600
W36×802	802	236	42.6	18	2.38	4.29	64800	4210
W36×723	723	213	41.8	17.8	2.17	3.9	57300	3700
W36×652	652	192	41.1	17.6	1.97	3.54	50600	3230
W36×529	529	156	39.8	17.2	1.61	2.91	39600	2490
W36×487	487	143	39.3	17.1	1.5	2.68	36000	2250
W36×441	441	130	38.9	17	1.36	2.44	32100	1990
W36×395	395	116	38.4	16.8	1.22	2.2	28500	1750
W36×361	361	106	38	16.7	1.12	2.01	25700	1570
W36×330	330	96.9	37.7	16.6	1.02	1.85	23300	1420
W36×302	302	89	37.3	16.7	0.945	1.68	21100	1300
W36×282	282	82.9	37.1	16.6	0.885	1.57	19600	1200
W36×262	262	77.2	36.9	16.6	0.84	1.44	17900	1090
W36×247	247	72.5	36.7	16.5	0.8	1.35	16700	1010
W36×231	231	68.2	36.5	16.5	0.76	1.26	15600	940
W36×256	256	75.3	37.4	12.2	0.96	1.73	16800	528
W36×232	232	68	37.1	12.1	0.87	1.57	15000	468

D.4.2 Wide Flange Section-SI

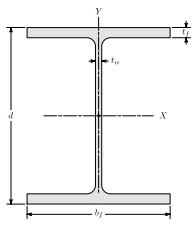

Description <i>d</i> × <i>W</i>	<i>W</i> kg/m	<i>A</i> mm ²	<i>d</i> mm	<i>b_f</i> mm	<i>t_w</i> mm	<i>t_f</i> mm	\bar{I}_{xx} 10 ⁶ mm ⁴	\bar{I}_{yy} 10 ⁶ mm ⁴
W1100×499	499	63500	1120	404	26.2	45	12900	499
W1100×433	433	55100	1110	401	22	40.1	11200	433
W1100×390	390	49800	1100	401	19.9	36.1	10000	384
W1100×343	343	43700	1090	401	18	31	8660	331
W1000×976	975	125000	1110	429	50	89.9	23500	1190
W1000×883	883	112000	1090	424	45.5	82	21000	1050
W1000×748	748	95500	1070	417	39.1	70.1	17300	849
W1000×642	642	81900	1050	411	34	59.9	14500	703
W1000×591	591	75500	1040	409	31	55.9	13300	641
W1000×554	554	71000	1030	409	29.5	52.1	12300	591
W1000×539	539	68400	1030	406	28.4	51.1	12000	574
W1000×483	483	61500	1020	404	25.4	46	10700	508
W1000×443	443	56300	1010	401	23.6	41.9	9660	454
W1000×412	412	52600	1010	401	21.1	40.1	9120	433
W1000×371	371	47400	1000	401	19.1	36.1	8160	385
W1000×321	321	41000	991	401	16.5	31	6950	334
W1000×296	296	37900	983	401	16.5	27.2	6200	289
W1000×584	584	74800	1060	315	36.1	64	12400	334
W1000×494	494	63000	1040	310	31	54.1	10300	268
W1000×486	486	61900	1040	307	30	54.1	10200	266
W1000×438	438	55600	1030	305	26.9	49	9120	234
W1000×415	415	53100	1020	305	26.2	46	8530	217
W1000×393	393	49900	1020	302	24.4	43.9	8070	205
W1000×350	350	44600	1010	302	21.1	40.1	7240	185
W1000×314	314	40100	1000	300	19.1	36.1	6450	162
W1000×272	272	34400	991	300	16.5	30.5	5490	138
W1000×249	249	31800	980	300	16.5	26.2	4830	118
W1000×222	222	28300	970	300	16	21.1	4080	95.3
W920×1377	1380	175000	1090	472	76.7	115	30400	2060
W920×1269	1270	162000	1090	462	64	115	29100	1910
W920×1194	1190	152000	1080	457	60.5	109	27000	1750
W920×1077	1080	137000	1060	452	55.1	99.1	23800	1540
W920×970	970	124000	1040	447	50	89.9	21100	1340
W920×787	787	101000	1010	437	40.9	73.9	16500	1040
W920×725	725	92300	998	434	38.1	68.1	15000	937
W920×656	656	83900	988	432	34.5	62	13400	828
W920×588	588	74800	975	427	31	55.9	11900	728
W920×537	537	68400	965	424	28.4	51.1	10700	653
W920×491	491	62500	958	422	25.9	47	9700	591
W920×449	449	57400	947	424	24	42.7	8780	541
W920×420	420	53500	942	422	22.5	39.9	8160	499
W920×390	390	49800	937	422	21.3	36.6	7450	454
W920×368	368	46800	932	419	20.3	34.3	6950	420
W920×344	344	44000	927	419	19.3	32	6490	391
W920×381	381	48600	951	310	24.4	43.9	6990	220
W920×345	345	43900	943	307	22.1	39.9	6240	195
W920×313	313	39900	932	310	21.1	34.5	5490	171
W920×289	289	36800	927	307	19.4	32	5040	156
W920×271	271	34600	922	307	18.4	30	4700	144