



### U2 FASTENERS

100 Main Street

Thunder Bay, Ontario, Canada

P7B 6R9

(807) 345-3119

[www.u2fasteners.com](http://www.u2fasteners.com)

### U2 FASTENERS COUNTERSINK UNIVERSAL SCREW, WASHER HEAD CONSTRUCTION SCREW, STAINLESS STEEL COUNTERSINK UNIVERSAL SCREW, STAINLESS STEEL WASHER HEAD CONSTRUCTION SCREW, FLAT HEAD SCREWS

#### CSI Section:

06 05 23 Wood, Plastic and Composite Fastenings

#### 1.0 RECOGNITION

The Countersink Universal Screws, Washer Head Construction Screws, Stainless Steel Countersink Universal Screws, Stainless Steel Washer Head Construction Screws, and Flat Head Screws manufactured by U2 Fasteners recognized in this report are dowel-type fasteners for use in construction. The physical, structural, and corrosion-resistance properties of the Countersink Universal Screws, Washer Head Construction Screws, Stainless Steel Countersink Universal Screws, Stainless Steel Washer Head Construction Screws, and Flat Head Screws comply with the intent of the provisions of the following codes and regulations:

- 2021, 2018, 2015, 2012, and 2009 International Building Code® (IBC)
- 2021, 2018, 2015, 2012, and 2009 International Residential Code® (IRC)

The screws are recognized for the structural performance characteristics described and tabulated in this evaluation report as well as for use with ACQ and MCA (for Flat Head Screws) preservative-treated wood.

#### 2.0 LIMITATIONS

Use of the U2 Fasteners Countersink Universal Screws, Washer Head Construction Screws, Stainless Steel Countersink Universal Screws, Stainless Steel Washer Head Construction Screws, and Flat Head Screws recognized in this report is subject to the following limitations:

2.1 Use shall comply with this report and the applicable code.

2.2 The minimum fastener end distances, edge distances, and spacing shall be in accordance with [Table 5 or Table 7](#) of this report or in accordance with the recommendations of the engineered wood product manufacturer, whichever is more restrictive.

2.3 Where installation causes splitting of the wood, holes are required to be pre-drilled in accordance with the ANSI/AWC National Design Specification (NDS) for wood-screw installation.

2.4 When designing a connection, the design shall comply with provisions in Sections 11.1.2, 11.2.2, and 12.6 of the 2018 and 2015 NDS, and Sections 10.1.2, 10.2.2, and 11.6 of the 2012 and 2005 NDS to ensure the capacity of the connection and fastener group.

2.5 The U2 fasteners shall be installed only in exposure conditions described in [Table 6](#) of this report.

2.6 U2 Fasteners Countersink Universal Screws, Washer Head Construction Screws, Stainless Steel Countersink Universal Screws, Stainless Steel Washer Head Construction Screws, and Flat Head Screws are packaged in Thunder Bay, Ontario.

#### 3.0 PRODUCT USE

U2 Fasteners Countersink Universal Screws, Washer Head Construction Screws, Stainless Steel Countersink Universal Screws, Stainless Steel Washer Head Construction Screws and Flat Head Screws are used as fasteners for wood-to-wood and engineered wood connections. The screws may be used where fasteners are required to exhibit corrosion resistance when exposed to adverse environmental conditions and/or preservative-treated wood, and are alternatives to hot-dip-zinc galvanized fasteners with a coating weight in compliance with ASTM A153, Class D. The U2 Fasteners Countersink Universal Screws, Washer Head Construction Screws, Stainless Steel Countersink Universal Screws, Stainless Steel Washer Head Construction Screws were evaluated for use with wood chemically treated with waterborne alkaline copper quaternary (ACQ-D) preservative. The U2 Fasteners Flat Head Screws were evaluated for use with wood chemically treated with micronized copper azole (MCA) preservative.

#### 3.1 Design:

3.1.1 **General:** Structural members forming the connection shall be designed in accordance with the IBC or IRC. Reference lateral and withdrawal design values in this report are for allowable stress design and shall be multiplied by the applicable adjustment factors, including wet service conditions specified in the NDS and this report, to determine





adjusted design values. Where the screws are subject to combined lateral and withdrawal loads, connections shall be designed in accordance with Section 12.4.1 of the 2018 and 2015 NDS, and Section 11.4.1 of the 2012 and 2005 NDS. When designing a connection, the structural members shall be analyzed for load-carrying capacity in accordance with Section 11.1.2 of the 2018 and 2015 NDS, and Section 10.1.2 of the 2012 and 2005 NDS.

The allowable load for a single screw connection in which the screw is subject to tension is the least of: (a) the reference withdrawal design value given in [Table 2](#) of this report, adjusted by all applicable adjustment factors; (b) the reference head pull-through design value given in [Table 4](#) of this report, adjusted by all applicable adjustment factors; and (c) the allowable screw tension strength given in [Table 1](#) of this report.

The allowable lateral load for a single screw connection is the lesser of: (a) the reference lateral design value given in [Table 3](#) of this report, adjusted by all applicable adjustment factors, and (b) the allowable screw shear strength given in [Table 1](#) of this report.

Connections containing multiple screws shall be designed in accordance with Sections 11.2.2 and 12.6 of the 2018 and 2015 NDS, and Sections 10.2.2 and 11.6 of the 2012 and 2005 NDS. Local stresses within the connection shall be checked using Appendix E in the NDS to ensure the capacity of the connection and fastener group.

**3.1.2 Lateral Design Values:** Reference lateral design values for Universal Screw, Construction Screws, Stainless Steel Universal Screw, and Stainless Steel Construction Screws for single shear wood-to-wood connections loaded parallel to grain are shown in [Table 3](#) of this report. Minimum connection geometries shall comply with [Table 5](#) of this report, as applicable.

**3.1.2.1 Lateral Design Values Determined in Accordance with the NDS:** The reference lateral design value for Universal Screws, Construction Screws, Stainless Steel Universal Screws, and Stainless Steel Construction Screws for wood-to-wood member connections may be designed in accordance with NDS, subject to the applicable parameters:

1. The applicable specified bending yield strength from [Table 1](#) of this report shall be used for design.
2. The specified root diameter shall be used where 'D' is referenced in Tables 12.3.1A, 12.3.1B, and 12.3.3 of the 2018 NDS (Tables 11.3.1A, 11.3.1B, and 11.3.3 of the 2012 NDS; and Tables 11.3.1A, 11.3.1B, and 11.3.2 of the 2005 NDS).
3. Applicable specific gravity as applicable in [Table 3](#) of this report.
4. The minimum side member thickness as applicable in [Table 3](#) of this report.
5. The minimum required main member fastener penetration as applicable in [Table 3](#) of this report.

6. The dowel bearing length in the main member as specified in [Table 1](#) of this report.
7. Spacing, edge, and end distance shall be as specified in [Table 5](#) of this report.

**3.1.3 Reference Withdrawal Design Values:** Reference withdrawal design values for U2 Fasteners Universal Screws Construction Screws, Stainless Steel Universal Screw, and Stainless Steel Construction Screws are shown in [Table 2](#) of this report. Loads are given in pounds per inch of thread penetration into the main member.

**3.1.4 Pull-Through Design Values:** Pull-through design values are shown in [Table 4](#) of this report.

**3.1.5 Universal Screw Header Attachment:** The No.12 x 3½-inch Universal Screw was specially developed to fasten 1½-inch-thick (38.1 mm) SYP lumber side members (SG = 0.55) and LVL side members having minimum equivalent specific gravity SG = 0.50, to SYP lumber holding members (SG = 0.55). The intended connection geometry is shown in [Figure 4](#) of this report. The minimum end and edge distances shown in [Figure 4](#) and [Table 7](#) of this report shall be respected for installation. The fasteners shall be designed using the allowable loads shown in [Table 7](#) of this report. The allowable single-screw capacities may be summed for multiple screw connections if the minimum allowable spacing required by the NDS is provided.

**3.2 Installation:** Countersink Universal Screws, Washer Head Construction Screws, Stainless Steel Countersink Universal Screws, Stainless Steel Washer Head Construction Screws, and Flat Head Screws shall be installed in accordance with the manufacturer's installation instructions, the evaluation report, and the codes listed in Section 1.0 of this report, using a low-speed drill. Where conflicts occur, the more restrictive shall govern. Edge distances, end distances, and spacing of the screws shall be sufficient to prevent splitting of the wood, or as required by [Table 5](#) or [Table 7](#) of this report. Installation may be performed without pre-drilling unless installation causes splitting of the wood members. For the U2 Fasteners Universal Screw, the top of the screw head shall be installed flush with the surface of the side member being connected. For the Construction Screw, the underside of the head shall be installed flush with the surface of the side member being connected.

## 4.0 PRODUCT DESCRIPTION

The Countersink Universal Screws, Washer Head Construction Screws, Stainless Steel Countersink Universal Screws, Stainless Steel Washer Head Construction Screws, and Flat Head Screws described in this report are alternative dowel-type threaded, self-tapping fasteners used for wood-to-wood and engineered wood connections. The screws are made of heat-treated hardened carbon steel or 316 Stainless Steel wire and are manufactured using a cold-forming process. The screws have rolled threads and a proprietary point. The Countersink Universal Screws and Stainless Steel



Countersink Universal Screws have flat heads with a star-drive recess. The Washer Head Construction Screws and Stainless Steel Washer Head Construction Screws have washer heads with a star-drive recess. The Flat Head Screws are torx-driven with a washer head with Talon Grip on the bottom side of the head, and reamer threads above the cutting threads. The screws are available in multiple lengths and diameters as described in [Table 1](#) of this report.

#### 4.1 Corrosion-resistant Coating:

**4.1.1** The Countersink Universal Screws and Washer Head Construction Screws are coated with U2 Fasteners Gold Color for corrosion protection. The coated screws are recognized for use in wood pressure-treated with waterborne alkaline copper quaternary (ACQ-D) preservative with a maximum retention of 0.60 pcf (9.6 kg/m<sup>3</sup>).

**4.1.2** The Flat Head Screws are coated with chromium and a proprietary black nano coating for corrosion protection. The coated screws are recognized for use in wood pressure-treated with micronized copper azole (MCA) preservative with a maximum retention of 0.21 pcf (3.3 kg/m<sup>3</sup>).

#### 5.0 IDENTIFICATION

The packaging for U2 Fasteners is labeled with the U2 Fastener name and address, the fastener designation and model identification, and the IAPMO UES Evaluation Report Number (IAPMO UES ER-454). The designations “Universal Screw” or “Construction Screw” for the Countersink Universal Screws, Washer Head Construction Screws, Stainless Steel Countersink Universal Screws, and Stainless Steel Washer Head Construction Screws, respectively, are included in the identification. The compatible treated wood type (0.60 pcf ACQ-D) is included, where applicable. Additionally, the Construction Screws are identified with an imprint on the head of each screw’s diameter and length. Either IAPMO UES Mark of Conformity may also be used as follows:

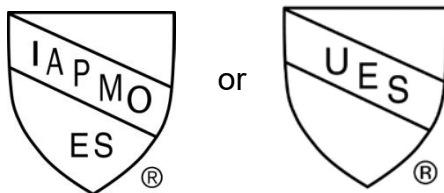

**IAPMO UES ER-454**

#### 6.0 SUBSTANTIATING DATA

**6.1** Data in accordance with Acceptance Criteria for Alternate Dowel-Type Threaded Fasteners Used in Wood (AC233).

**6.2** Data in accordance with Acceptance Criteria for Corrosion-Resistant Fasteners and Evaluation of Corrosion Effects of Wood Treatments (AC257).

**6.3** Quality control manual.

**6.4** Test reports are from laboratories in compliance with ISO/IEC 17025.

#### 7.0 STATEMENT OF RECOGNITION

This evaluation report describes the results of research completed by IAPMO Uniform Evaluation Service on U2 Fasteners Countersink Universal Screws, Washer Head Construction Screws, Stainless Steel Countersink Universal Screws, Stainless Steel Washer Head Construction Screws, and Flat Head Screws to assess their conformance to the codes shown in Section 1.0 of this report and serves as documentation of the product certification. The fasteners are produced at the location noted in Section 2.6 of this report under a quality control program with periodic inspections under the supervision of IAPMO UES.

For additional information about this evaluation report please visit [www.uniform-es.org](http://www.uniform-es.org) or email us at [info@uniform-es.org](mailto:info@uniform-es.org)



**TABLE 1 – U2 FASTENERS COUNTERSINK UNIVERSAL SCREW, WASHER HEAD CONSTRUCTION SCREW, STAINLESS STEEL COUNTERSINK UNIVERSAL SCREW, STAINLESS STEEL WASHER HEAD CONSTRUCTION SCREW, AND FLAT HEAD SCREW ALLOWABLE BENDING YIELD STRENGTH AND FASTENER ALLOWABLE STEEL STRENGTH**

FASTENER DESIGNATION	FASTENER ID	FASTENER LENGTH, L (in.)	THREAD LENGTH, L <sub>t</sub> (in.)	EFFECTIVE TIP LENGTH, E (in.)	HEAD DIAMETER d <sub>h</sub> (in.)	MINOR THREAD (ROOT) DIAMETER, d <sub>t</sub> (in.)	UNTHREADED SHANK DIAMETER (in.)	MAJOR THREAD (OUTSIDE) DIAMETER, d (in.)	FASTENER ALLOWABLE STEEL STRENGTH			
									Bending Yield Strength (F <sub>yb</sub> ) (psi)	Tensile (lbf)	Shear (lbf) Threaded Section	Shear (lbf) Unthreaded Shank
U2 Universal Screws (Countersink Screws)	9 x 2 1/2"	2 1/2	1 1/2	1.39	0.329	0.113	0.131	0.176	215,000	590	337	386
	9 x 2 3/4"	2 3/4	2	1.89								
	9 x 3 1/8"	3 1/8	1 1/2	1.39								
	10 x 2 1/2"	2 1/2	1 1/2	1.37	0.371	0.130	0.146	0.197				
	10 x 3 1/8"	3 1/8	2	1.87								
	10 x 4"	4	2 1/2	2.37								
	10 x 4 1/2"	4 1/2	3	2.87								
	12 x 3 1/2"	3 1/2	2 1/4	2.10	0.441	0.154	0.172	0.237				
	12 x 5"	5	3	2.85								
12 x 6"	6	4	3.85									
CS Construction Screws (Washer Head Screws)	10 x 3 1/8"	3 1/8	1 1/2	1.38	0.632	0.170	0.197	0.274	225,000	768	413	-
	5/16 x 2 1/2"	2 1/2	1 1/2	1.33								
	5/16 x 3 1/8"	3 1/8	1 1/2	1.33								
	5/16 x 4"	4	2 1/2	2.33								
	5/16 x 5"	5	3	2.83	0.715	0.194	0.225	0.312				
	5/16 x 6"	6	4	3.83								
	3/8 x 6"	6	3 1/2	3.31								
	3/8 x 7"	7	3 1/2	3.31	0.328	0.112	0.135	0.172				
9 x 2"	2	1 1/3	1.22									
10 x 2 1/2"	2 1/2	1 1/2	1.37									
UNI Stainless Steel Universal Screws (Countersink Screws)	10 x 3"	3	2	1.87	0.366	0.129	0.147	0.194	165,000	475	318	327
	5/16 x 2 1/2"	2 1/2	1 1/2	1.32								
	5/16 x 4"	4	2 1/2	2.32								
	5/16 x 5"	5	3	2.82								
316CS Stainless Steel Construction Screws (Washer Head Screws)	5/16 x 6"	6	4	3.82	0.621	0.176	0.201	0.275	200,000	1,067	776	874
	25/64 x 3 3/8"	3 3/8	1 1/2	1.13								
	25/64 x 4"	4	2 1/2	2.13								
	25/64 x 5"	5	3	2.63								
FH Flat Head Screws	25/64 x 6"	6	4 1/2	4.13	0.968	0.246	0.279	0.392	192,000	2,592	1,932	2,042

For SI: 1 inch = 25.4 mm, 1 psi = 6.89 kPa, 1 lbf = 4.45 N

- For fasteners with countersink-type heads, the overall fastener length shall be measured from the top of the head to the bottom of the point. For fasteners with washer-type heads, the overall fastener length shall be measured from the underside of the head to the bottom of the point.
- Thread length includes the point, as shown in [Figure 1](#) of this report.
- Bending yield strength is determined by methods specified in ASTM F1575 and based on the minor thread (root) diameter.

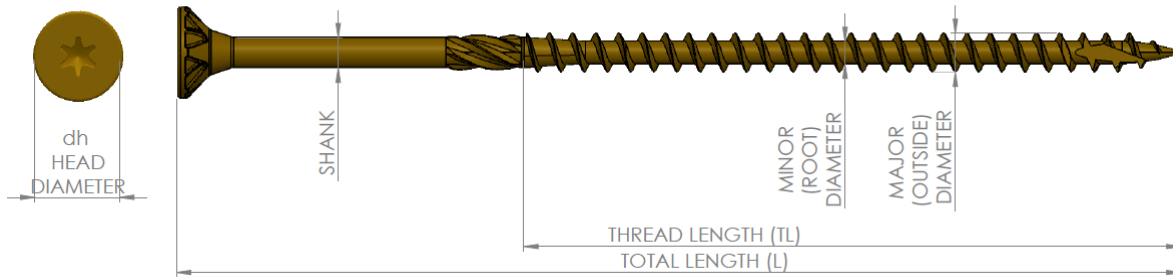

FIGURE 1 – U2 FASTENERS COUNTERSINK UNIVERSAL AND STAINLESS STEEL COUNTERSINK UNIVERSAL SCREWS

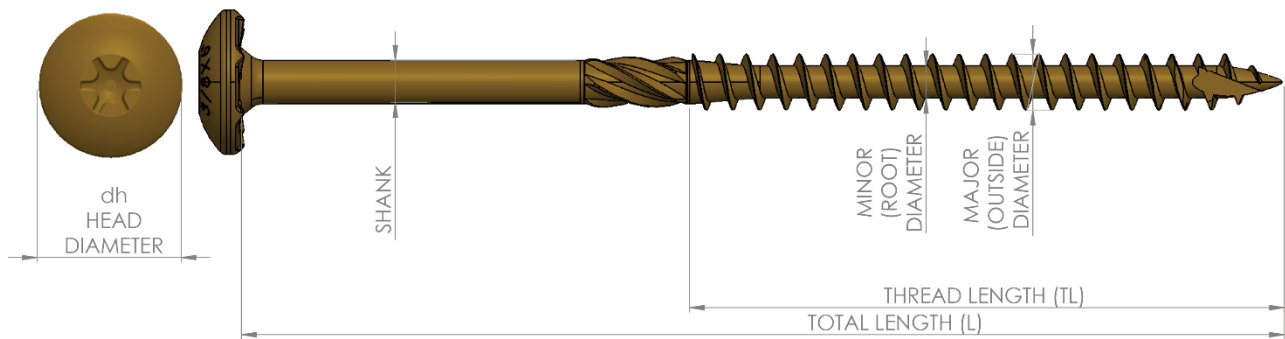

FIGURE 2 – WASHER HEAD CONSTRUCTION SCREW AND STAINLESS STEEL WASHER HEAD CONSTRUCTION SCREW

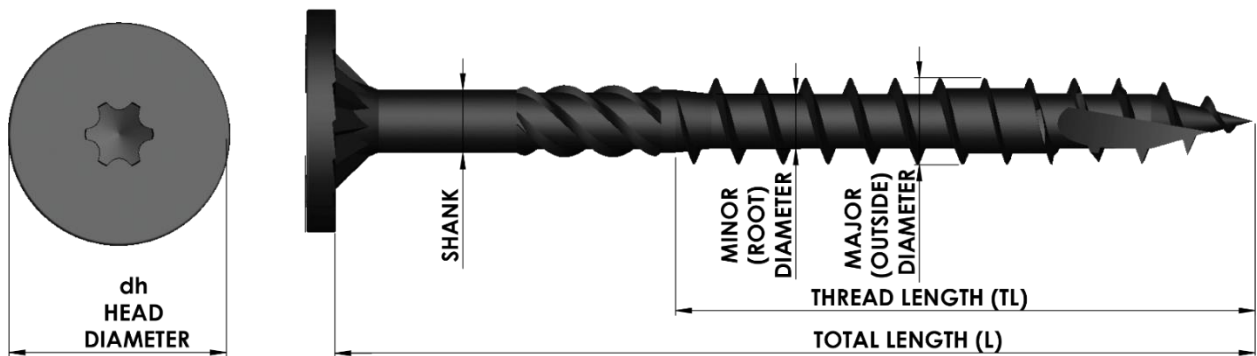

FIGURE 3 – FLAT HEAD SCREW



**TABLE 2 – REFERENCE WITHDRAWAL (W) DESIGN VALUES FOR WOOD-TO-WOOD CONNECTIONS WITH UNIVERSAL SCREWS, CONSTRUCTION SCREWS, AND FLAT HEAD SCREWS<sup>1,2,3,4,5</sup>**

FASTENER DESIGNATION		FASTENER ID	THREAD LENGTH, L <sub>t</sub> (in.)	REFERENCE WITHDRAWAL DESIGN VALUES, W (lbf/in.)					WET SERVICE FACTOR, C <sub>M</sub>
				SG = 0.36	SG = 0.42	SG = 0.50	SG = 0.55	LVL Equiv. SG = 0.50	
U2	Universal Screws (Countersink Screws)	9 x 2½"	1½	84	74	101	105	147	0.70
		9 x 2¾"	2	75	96	125	143	152	
		9 x 3⅛"	1½	76	90	109	121	140	
		10 x 2½"	1½	74	93	117	133	159	
		10 x 3⅛"	2	74	93	117	133	159	
		10 x 4"	2½	74	93	117	133	159	
		10 x 4½"	3	109	125	147	161	162	
		12 x 3½"	2¼	97	119	152	171	172	
12 x 5"	3								
12 x 6"	4								
CS	Construction Screws (Washer Head Screws)	10 x 3⅛"	1½	90	98	109	116	148	
		5/16 x 2½"	1½	112	139	174	196	162	
		5/16 x 3⅛"	1½	118	137	161	177	166	
		5/16 x 4"	2½	125	150	184	205	187	
		5/16 x 5"	3	114	137	161	177	162	
		5/16 x 6"	4	159	166	198	207	215	
		3/8 x 6"	3½	114	142	180	203	198	
3/8 x 7"	3½	106	151	210	247	215			
UNI	Stainless Steel Universal Screws (Countersink Screws)	9 x 2"	1⅓	105	129	157	---	130	
		10 x 2½"	1½	134	131	152	---	148	
		10 x 3"	2	177	173	190	---	183	
316CS	Stainless Steel Construction Screws (Washer Head Screws)	5/16 x 2½"	1½	146	169	181	207	173	
		5/16 x 4"	2½	146	169	181	185	173	
		5/16 x 5"	3	146	169	181	185	173	
		5/16 x 6"	4	148	180	183	185	177	
FH	Flat Head Screws	25/64 x 3⅜"	1½	127	149	179	212	145	0.70
		25/64 x 4"	2½	149	187	224	269	183	
		25/64 x 5"	3	149	187	224	269	183	
		25/64 x 6"	4	149	187	224	269	183	

For SI: 1 inch = 25.4 mm, 1 psi = 6.89 kPa, 1 lbf = 4.45 N

- Values shall be multiplied by all applicable adjustment factors as set forth in the NDS unless fastener strength controls connection strength, in which case, values shall not be multiplied by any adjustment factors.
- Reference withdrawal design values shall be multiplied by the length of thread penetration in the main member. Length includes a tapered tip. Minimum penetration shall be one inch.
- Specific Gravity (SG) shall be the specific gravity assigned for sawn lumber or wood structural panels per Table 12.3.3A or 12.3.3B of the 2018 and 2015 NDS (Table 11.3.3A or 11.3.3B of the 2012 NDS and 2005 NDS), as applicable, or the engineered wood product equivalent specific gravity given in the applicable evaluation report.
- Test data was generated with samples within ±10 percent of stated nominal specific gravity values.
- Screws shall be installed straight into the side grain of the wood main members with the screw axis at a 90-degree angle to the wood fibers.



**TABLE 3 – REFERENCE LATERAL (Z) DESIGN VALUES FOR WOOD-TO-WOOD CONNECTIONS (PARALLEL TO GRAIN) WITH UNIVERSAL SCREWS, CONSTRUCTION SCREWS, AND FLAT HEAD SCREWS<sup>1,2,3,4,5</sup>**

FASTENER DESIGNATION	FASTENER ID	SIDE MEMBER THICKNESS, T <sub>s</sub> (in.)	MAIN MEMBER FASTENER PENETRATION, P (in.)	ALLOWABLE SHEAR LOADS (lbf)					WET SERVICE FACTOR <sup>6</sup> , C <sub>M</sub>	
				SG = 0.36	SG = 0.42	SG = 0.50	SG = 0.55	LVL Equiv. SG = 0.50		
U2	Universal Screws (Countersink Screws)	9 x 2 1/2"	1 1/2	1	72	78	93	106	119	0.70 <sup>6</sup>
		9 x 2 3/4"	1 1/2	1 1/4	90	109	134	150	134	
		9 x 3 1/8"	1 1/2	1 1/2	84	108	140	161	157	
		10 x 2 1/2"	1 1/2	1	80	99	125	143	125	
		10 x 3 1/8"	1 1/2	1 5/8	146	153	150	183	213	
		10 x 4"	1 1/2	2 1/2	122	122	133	166	174	
		10 x 4 1/2"	3 1/2	1	100	122	151	169	173	
		12 x 5"	1 1/2	3 1/2	134	166	165	156	200	
12 x 6"	3 1/2	2 1/2	152	202	290	344	269			
CS	Construction Screws (Washer Head Screws)	10 x 3 1/8"	1 1/2	1 1/2	106	145	198	230	184	0.70 <sup>6</sup>
		5/16 x 2 1/2"	1 1/2	1	106	139	185	210	185	
		5/16 x 3 1/8"	1 1/2	1 1/2	122	161	223	258	223	
		5/16 x 4"	3 1/2	1 1/2	197	212	233	246	241	
		5/16 x 5"	1 1/2	3 1/2	202	270	225	217	225	
		5/16 x 6"	1 1/2	4 1/2	251	314	381	363	308	
		3/8 x 6"	3 1/2	2 1/2	212	262	362	425	290	
		3/8 x 7"	3 1/2	3 1/2	294	341	405	445	353	
UNI	Stainless Steel - Universal Screws (Countersink Screws)	9 x 2"	1 1/2	1 1/2	76	92	84	110	129	0.70 <sup>6</sup>
		10 x 2 1/2"	1 1/2	1	78	106	115	127	116	
		10 x 3"	1 1/2	1 1/2	139	143	146	167	199	
3/16CS	Construction Screws (Washer Head Screws)	5/16 x 2 1/2"	1 1/2	1	138	148	152	147	181	0.70 <sup>6</sup>
		5/16 x 4"	1 1/2	2 1/2	233	260	327	216	231	
		5/16 x 5"	1 1/2	3 1/2	233	260	327	216	231	
		5/16 x 6"	3 1/2	2.5	241	321	377	381	322	
FH	Flat Head Screws	25/64 x 3 3/8"	1 1/2	1 7/8	224	304	337	423	----	----
		25/64 x 4"	1 1/2	2 1/2	224	304	337	423	----	
		25/64 x 5"	1 1/2	3 1/2	224	304	337	423	----	

For SI: 1 inch = 25.4 mm, 1 psi = 6.89 kPa, 1 lbf = 4.45 N

- Values shall be multiplied by all applicable adjustment factors as set forth in the NDS unless fastener strength controls connection strength, in which case, values shall not be multiplied by any adjustment factors.
- Specific Gravity (SG) shall be the specific gravity assigned for sawn lumber or wood structural panels per Table 12.3.3A or 12.3.3B of the 2018 and 2015 NDS (Table 11.3.3A or 11.3.3B of the 2012 NDS and 2005 NDS), as applicable, or the engineered wood product equivalent specific gravity given in the applicable evaluation report.
- Test data was generated with samples within ±10 percent of stated nominal specific gravity values. When the specific gravities or equivalent specific gravities of the main or side members are different, the design values of the wood with the lowest specific gravity shall be used.
- Screws shall be installed straight into the side grain of the wood main members with the screw axis at a 90-degree angle to the wood fibers.
- Minimum fastener penetration shall be equal to the screw length less the thickness of the wood side plate.
- For SG = 0.55, the Wet Service Factor shall be C<sub>M</sub> = 0.6 maximum.



**TABLE 4 – REFERENCE PULL-THROUGH (P) DESIGN VALUES FOR WOOD-TO-WOOD CONNECTIONS WITH UNIVERSAL SCREWS, CONSTRUCTION SCREWS, AND FLAT HEAD SCREWS<sup>1,2,3,4</sup>**

FASTENER DESIGNATION		FASTENER ID	MINIMUM SIDE MEMBER THICKNESS, T <sub>s</sub> (in.)	REFERENCE PULL-THROUGH DESIGN VALUES, P (lbf)					WET SERVICE FACTOR, C <sub>M</sub>
				SG = 0.36	SG = 0.42	SG = 0.50	SG = 0.55	LVL Equiv. SG = 0.50	
U2	Universal Screws (Countersink Screws)	9 x 2 1/2"	1 1/2	62	69	78	84	168	0.70
		9 x 2 3/4"							
		9 x 3 1/8"							
		10 x 2 1/2"							
		10 x 3 1/8"							
		10 x 4"							
		10 x 4 1/2"							
12 x 3 1/2"									
12 x 6"									
CS	Construction Screws (Washer Head Screws)	10 x 3 1/8"		169	234	321	375	387	
		5/16 x 2 1/2"		292	294	370	398	495	
		5/16 x 3 1/8"							
		5/16 x 4"							
		5/16 x 5"							
		5/16 x 6"							
		3/8 x 6"							
3/8 x 7"									
UNI	Stainless Steel - Universal Screws (Countersink Screws)	9 x 2"	3/4	57	71	101	---	94	
		10 x 2 1/2"	3/4	66	81	110	---	110	
		10 x 3"	1 1/2	114	138	153	---	225	
316CS	Stainless Steel Construction Screws (Washer Head Screws)	5/16 x 2 1/2" 5/16 x 4" 5/16 x 5" 5/16 x 6"	1 1/2	353	395	402	500	515	
FH	Flat Head Screws	25/64 x 3 3/8"	1 1/2	537	731	780	992	---	---
		25/64 x 4"							
		25/64 x 5"							
		25/64 x 6"							

For SI: 1 inch = 25.4 mm, 1 psi = 6.89 kPa, 1 lbf = 4.45 N

- Values shall be multiplied by all applicable adjustment factors as set forth in the NDS unless fastener strength controls connection strength, in which case, values shall not be multiplied by any adjustment factors.
- Specific Gravity shall be the assigned specific gravity for sawn lumber or wood structural panels per Table 12.3.3A or 12.3.3B of the 2018 and 2015 NDS (Table 11.3.3A or 11.3.3B of the 2012 NDS and 2005 NDS), as applicable, or the engineered wood product equivalent specific gravity given in the applicable evaluation report.
- Test data generated with samples within ±10 percent of stated nominal specific gravity values.
- Screws shall be installed straight into the side grain of the wood main members with the screw axis at a 90-degree angle to the wood fibers.

**TABLE 5 – CONNECTION GEOMETRY FOR UNIVERSAL SCREWS AND CONSTRUCTION SCREWS**

CONDITION		2018 and 2015 NDS C12.1.5.7 (2012 and 2005 NDS C11.1.5.7)	MINIMUM DISTANCE OR SPACING (inches) <sup>2</sup>									
			SPECIFIC GRAVITY < 0.5					SPECIFIC GRAVITY ≥ 0.5				
			#9	#10	#12	5/16	3/8	#9	#10	#12	5/16	3/8
End Distance	Tension Loading Parallel to Grain	15D	2 1/2	2 7/8	3 7/16	4	4	3 3/8	3 7/8	4	4	4
	Compression Loading Parallel to Grain	10D	1 11/16	1 15/16	2 5/16	2 11/16	3 1/16	2 1/2	2 7/8	3 7/16	4	4
	Loading Perpendicular to Grain	10D	1 11/16	1 15/16	2 5/16	2 11/16	3 1/16	2 1/2	2 7/8	3 7/16	4	4
Edge Distance	Loading Parallel to Grain	5D	1 3/16	1 5/16	1 1/8	1 5/16	1 1/8	1 3/16	1 5/16	1 9/16	1 1/8	2 1/8
	Loading Perpendicular to Grain Toward Edge	10D	1 11/16	1 15/16	2 5/16	2 11/16	3 1/16	2	2 5/16	2 3/4	3 1/4	3 11/16
	Loading Perpendicular to Grain Away from Edge	5D	1 3/16	1 5/16	1 1/8	1 5/16	1 1/8	1 3/16	1 5/16	1 9/16	1 1/8	2 1/8
Spacing Between Fasteners	Loading Parallel To Grain	15D	2 1/2	2 7/8	3 7/16	4	4	2 1/2	2 7/8	3 7/16	4	4
	Loading Perpendicular To Grain	10D	2	2 5/16	2 3/4	3 1/4	3 11/16	2 1/2	2 7/8	3 7/16	4	4
Spacing Between Rows	In-Line Rows	5D	1 3/16	1 5/16	1 1/8	1 5/16	1 1/8	1 3/16	1 5/16	1 9/16	1 1/8	2 1/8
	Staggered Rows <sup>3</sup>	2.5D	3/8	7/16	9/16	5/16	3/4	1/2	9/16	1 1/16	1 3/16	7/8

For SI: 1 inch = 25.4 mm, 1 psi = 6.89 kPa, 1 lbf = 4.45 N

- Table 7 of this report indicates the required spacing.
- End distances, edge distances, and screw spacing shall be sufficient to prevent splitting of the wood, or as required by this table, whichever is the most restrictive unless otherwise noted in Table 7 of this report. Values for spacing between staggered rows apply where screws in adjacent rows are offset by half of the spacing between screws in a row.

**TABLE 6 – EXPOSURE CONDITIONS FOR FASTENERS WITH INTENDED USE AND LIMITATIONS OF RECOGNITION**

EXPOSURE CONDITION	TYPICAL APPLICATIONS	RECOGNITION LIMITATIONS
	CORROSION RESISTANCE OF FASTENERS	
1	Treated wood in dry-use applications	Limited to use where the equilibrium moisture content of the chemically treated wood meets dry service conditions as described in the NDS
3	General construction	Limited to freshwater and chemically treated wood exposure. The fasteners are not for use under saltwater exposure.

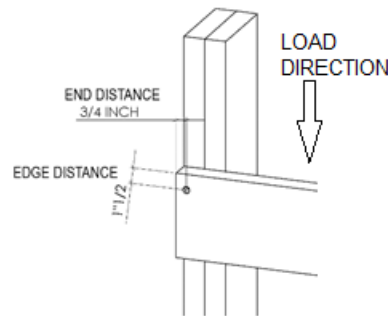

**FIGURE 4 – CONNECTION GEOMETRY APPLICABLE TO TABLE 7**

**TABLE 7 -- ALLOWABLE LATERAL STRENGTH VALUES FOR No.12x3 1/2-INCH-LONG UNIVERSAL SCREWS TO CONNECT SYP LUMBER OR LVL SIDE MEMBERS TO SYP MAIN MEMBERS (lbf)**

FASTENER DESIGNATION	FASTENER ID	SIDE MEMBER THICKNESS, T <sub>s</sub> (in.)	MINIMUM FASTENER PENETRATION, P INTO MAIN MEMBER (in.)	ALLOWABLE LATERAL STRENGTH (lbf)	
				SYP	LVL
Universal Screw	12 x 3 1/2"	1 1/2	2	276	232

SI: 1 inch = 25.4 mm; 1 lbf = 4.4 N

**Notes**

1. Allowable lateral strength values for multiple screws are additive provided minimum required spacing is maintained.
2. Minimum screw spacing in the same row shall comply with the NDS.
3. The fasteners into the side member are loaded perpendicular to grain; the fasteners in the holding member are loaded parallel to grain.
4. The minimum fastener end distance into the side member shall be 3/4-inch; the minimum screw edge distance in the main member shall be nominally 3/4 inch. The minimum edge distance of screws into side members shall be 1.5 inches from the loaded edge.
5. SYP specific gravity is 0.55, and LVL minimum equivalent specific gravity shall be 0.50.
6. The allowable lateral strength values may be applied for the same connection using No. 12 Universal Screws longer than 3 1/2 inches.